

Description

The FS1023-DG Gas Flow Sensor Module measures the flow rate using the thermo-transfer (calorimetric) principle.

The FS1023-DG offers key advantages over resistor-based flow solutions. The sensor utilizes thermopile sensing, which provides an excellent signal-to-noise ratio. The sensor comprises a "solid" thermal isolation technology with protective coating.

The FS1023-DG provides calibrated linear output through digital I2C and analog interface.

Typical Applications

- Ventilators
- Gas metering equipment
- Process controls and monitoring

Features

- Gas flow: 0 to 35 liters/min
- Robust "solid" isolation technology
- Resistant to vibration and pressure shock
- Minimal flow resistance
- Fast response: < 5ms
- Digital I2C output
- Analog voltage output
- Supply voltage: 5V

FS1023-DG Flow Sensor Module



COMPONENT

Pin Assignments

Figure 1. Pin Assignments for Module – Top View

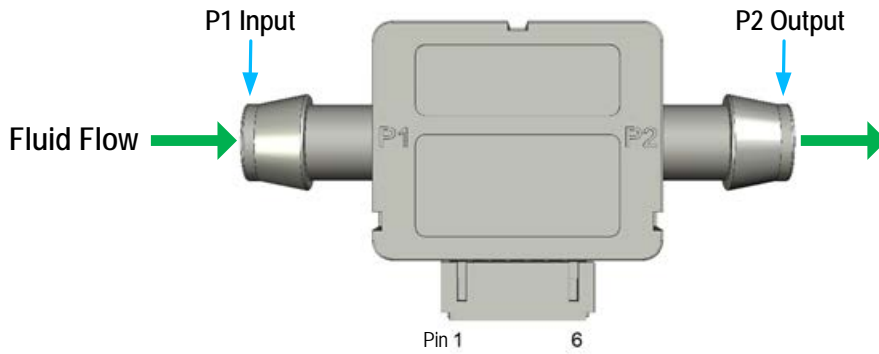

Pin Descriptions

Table 1. Pin Descriptions

Pin Number	Pad Name	Description
1	VDD	Supply voltage
2	GND	Ground
3	OUTPUT	Flow analog output
4	SDA	Serial data
5	SCL	Serial clock
6	NC	Do not connect ^[a]

[a] "NC" stands for not connected / no connection required / not bonded.

Absolute Maximum Ratings

The absolute maximum ratings are stress ratings only. Stresses greater than those listed below can cause permanent damage to the device. Functional operation of the FS1023-DG at absolute maximum ratings is not implied. Exposure to absolute maximum rating conditions might affect device reliability.

Table 2. Absolute Maximum Ratings

Symbol	Parameter	Conditions	Minimum	Maximum	Units
V _{IN}	Supply Voltage		2.7	5.5	V
T _{STOR}	Storage Temperature		0	105	°C

Operating Conditions

The FS1023-DG is optimized for operating at 5V in room temperature.

Table 3. Recommended Operating Conditions

Symbol	Parameter	Minimum	Typical	Maximum	Units
V _{IN}	Supply Voltage		5		V
T _{AMB}	Ambient Operating Temperature (in air)	0	25	85	°C
P _{CM}	Common-Mode Pressure			30	PSI

Electrical Characteristics

Table 4. Electrical Characteristics

Symbol	Parameter	Conditions	Minimum	Typical	Maximum	Units
I _{VIN}	Current Consumption			21		mA
F _{LO}	Gas Flow Range		0		35	Liters/min
V _{AOUT}	Analog Output	At 0 liters/min		0.5		V
		At 35 liters/min		4.5		
V _{DOUT}	Digital Output	At 0 liters/min		409		Counts
		At 35 liters/min		3686		
E _{Flow}	Flow Accuracy ^[a]			1.5	5	% Reading
τ _H	Flow Response Time ^[b]			5		msec

[a] Calibration Standard Condition: 25°C, 1bar.

[b] The flow response time includes a 10% to 90% rise time for the flow sensor to electrically respond to any gas flow change. Measurements might be affected by the pneumatic interface.

Flow Graphs

The graph in Figure 2 and Figure 3 shows the digital and analog output versus flow, at 25°C.

Figure 2. Digital Output

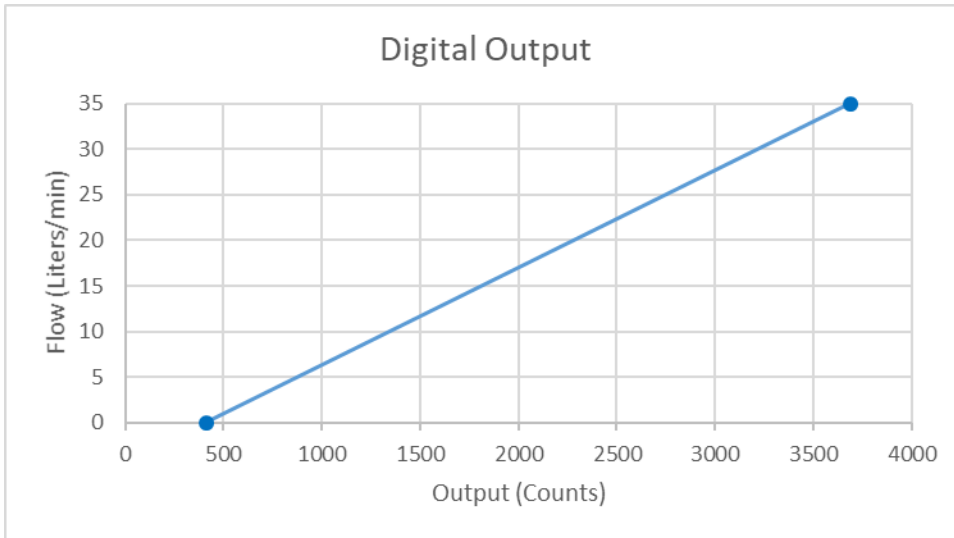

Flow (Liters/min)	Digital Output (Counts)
0	409
35	3686

Figure 3. Analog Output

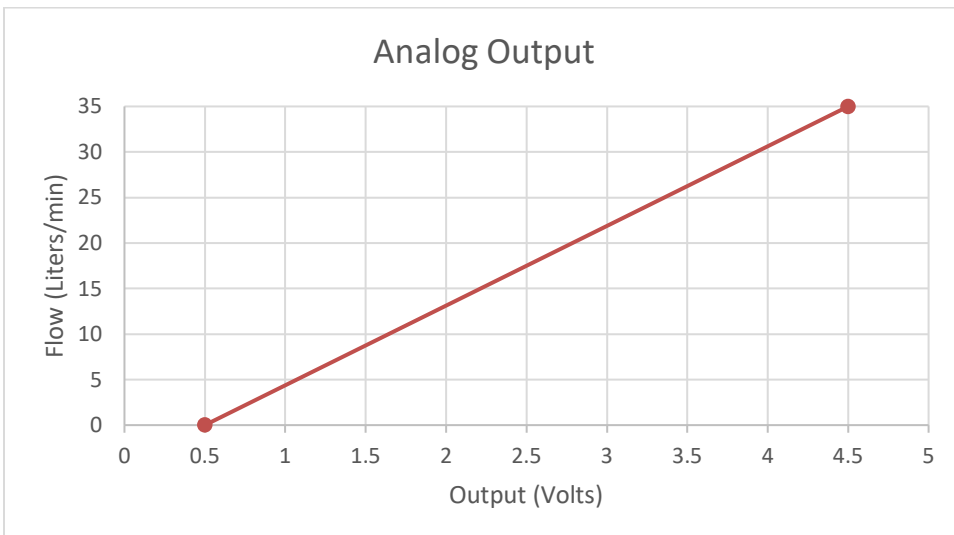

Flow (Liters/min)	Analog Output (Volts)
0	0.5
35	4.5

I2C Sensor Interface

The FS1023-DG includes a digital I2C two-wire interface with a bidirectional data line (SDA) and a clock line (SCL). The two lines are open drain and connected to the supply voltage via two pull-up resistors (Rp). The FS1023-DG operates as a slave device on the I2C bus with support of 100kHz and 400kHz bit rates.

Figure 4. I2C Master-Slave Configuration

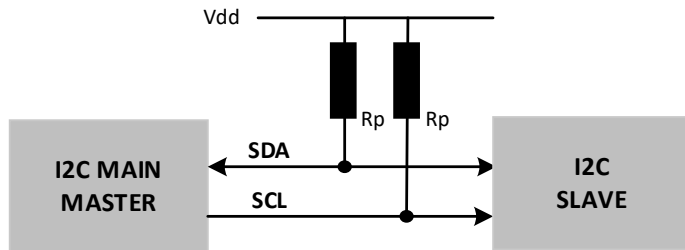

The recommended pull-up resistor (Rp) values depend on the system implementation, but a value between 2.2kΩ and 10kΩ can be used. The capacitive load on both SDA and SCL should be the same, hence the signal lengths should be similar to avoid asymmetry.

Sensor Slave Address

The FS1023-DG default I2C address is 50_{HEX}. The device will respond only to this 7-bit address.

I2C Communication

The START condition is used to initiate I2C communication by the master. The sensor transmission is initiated when the master sends a 0 START bit (S). A HIGH to LOW transition on the SDA line while the SCL is HIGH indicates the beginning of a transmission.

The STOP condition is used to stop I2C communication by the master. The transmission is terminated when the master sends a 1 STOP bit (P). A LOW to HIGH transition on the SDA line while the SCL is HIGH indicates the end of a transmission.

All transfers consist of 8 bits and a response bit: 0 for Acknowledge (ACK) or 1 for Not Acknowledge (NACK). After the ACK is received, another data byte can be transferred or the communication can be stopped with a STOP bit.

The master expects an ACK back from the slave after each byte is transmitted. The slave pulls the SDA low to indicate that it has received a byte and then it frees the I2C bus again. If the slave does not initiate an ACK, then it will consider it a NACK.

Data on the SDA line is always sampled on the rising edge of the SCL line and must remain stable while SCL is HIGH to prevent false START or STOP conditions.

Figure 5. START and STOP Condition Waveform

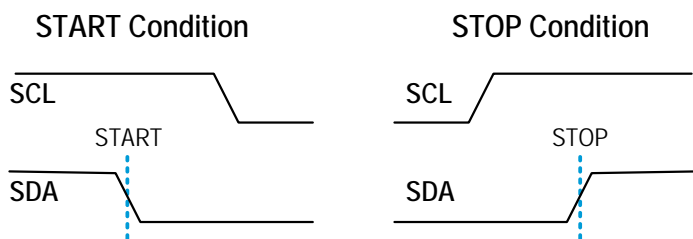

Digital Output Measurements

The FS1023-DG continuously measures in operation.

The data is sent in byte packages. Each byte is followed by an ACK from the slave. The most significant bit (MSB) is transmitted first.

To read the data, the following command is sent to the FS1023-DG.

After the START bit, the master device sends the 7-bit slave address followed by an eighth bit = 1 (READ). The READ bit indicates a transmission from the FS1023-DG (slave) to master. See Figure 6.

The checksum used for data integrity is returned from the FS1023-DG followed by the two bytes of flow data.

The flow data is a 12-bit integer. Only the least significant four bits in the high byte are valid. See Figure 7.

Figure 6. Flow Data Read Command

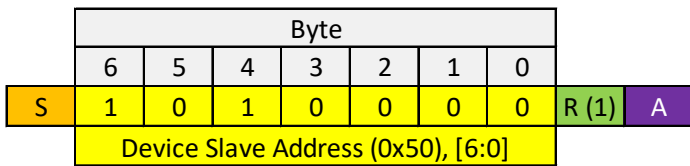
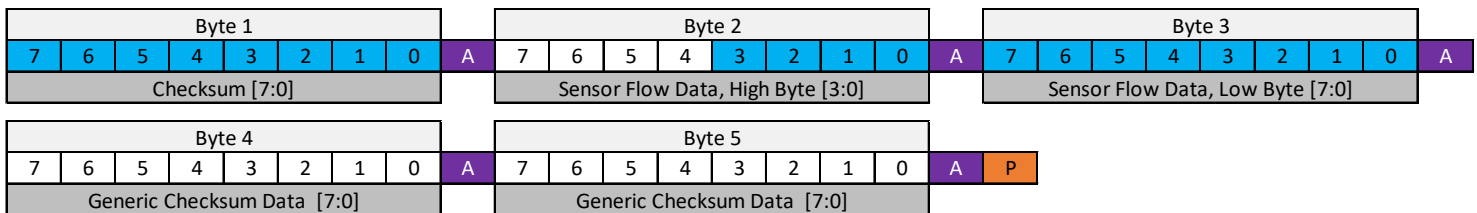

Figure 7. Flow Data from FS1023-DG



S START Condition

R READ Mode

P STOP Condition

A Acknowledge (ACK)

Calculating Flow Output

The flow rate for the digital and analog output are calculated with Equation 1 and Equation 2, respectively.

$$\text{Flow rate (liters/min)} = \frac{\text{Output (counts)} - 409}{3277} * 35 \quad \text{Equation 1}$$

$$\text{Flow rate (liters/min)} = \frac{\text{Output (analog)} - 0.5}{4} * 35 \quad \text{Equation 2}$$

Calculating Checksum

The checksum used for data integrity is the 2's complement (negative) of the 256-modulo (8-bit) sum of the data bytes (does not include I2C address).

Figure 7 shows the 5 bytes read:

Example:

Byte 1, 0xCC (Checksum)

Byte 2, 0x01

Byte 3, 0x99

Byte 4, 0x01 or 0x00

Byte 5, 0x99 or 0x00

The 256-modulo (8-bit) sum is calculated as:

$$\text{sum} = 0x01 + 0x99 + 0x01 + 0x99 = 0x134$$

Validating the data payload is done by calculating the sum and adding it to the checksum. If the result is 0x00, then the data is valid.

$$\text{checksum} + \text{sum} = 0xCC + 0x134 = 0x00$$

Electrical Connector

A 6-position receptacle (not provided) is required to mate to the board crimp style connector. A part number example is PHR-6 (JST).

Figure 8. Receptacle Drawing

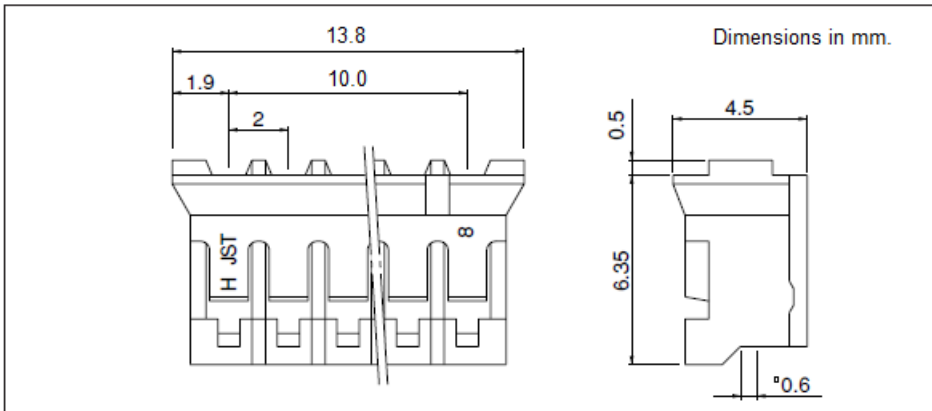

Module Material

The wetted contact surface of the FS1023-DG consists of the following:

- Housing – Polyphenylene Ether (PPE) + Polystyrene (PS) blend resin
- Parylene
- Gasket – Silicone

Tubing Guidance

The FS1023-DG module has barb tube endings. Soft tubing with a nominal 3/8inch (9.5mm) internal diameter is recommended for use. A clamp may be necessary to secure the tubing over the barb.

Mechanical Drawings

The package outline drawings are appended at the end of this document and are accessible from the link below. The package information is the most current data available.

www.idt.com/us/en/document/psc/fs1023-package-outline-drawing580-x-315-mm-modulemod0d1

Ordering Information

Orderable Part Number	Description and Package	Shipping Packaging	Temperature
FS1023-1001-DG	0 to 35 liter/min gas flow sensor module with digital and analog voltage output	Box	0°C to +85°C

Revision History

Revision Date	Description of Change
September 25, 2020	Updated flow accuracy spec, flow output charts, and checksum example
April 28, 2020	Initial Release

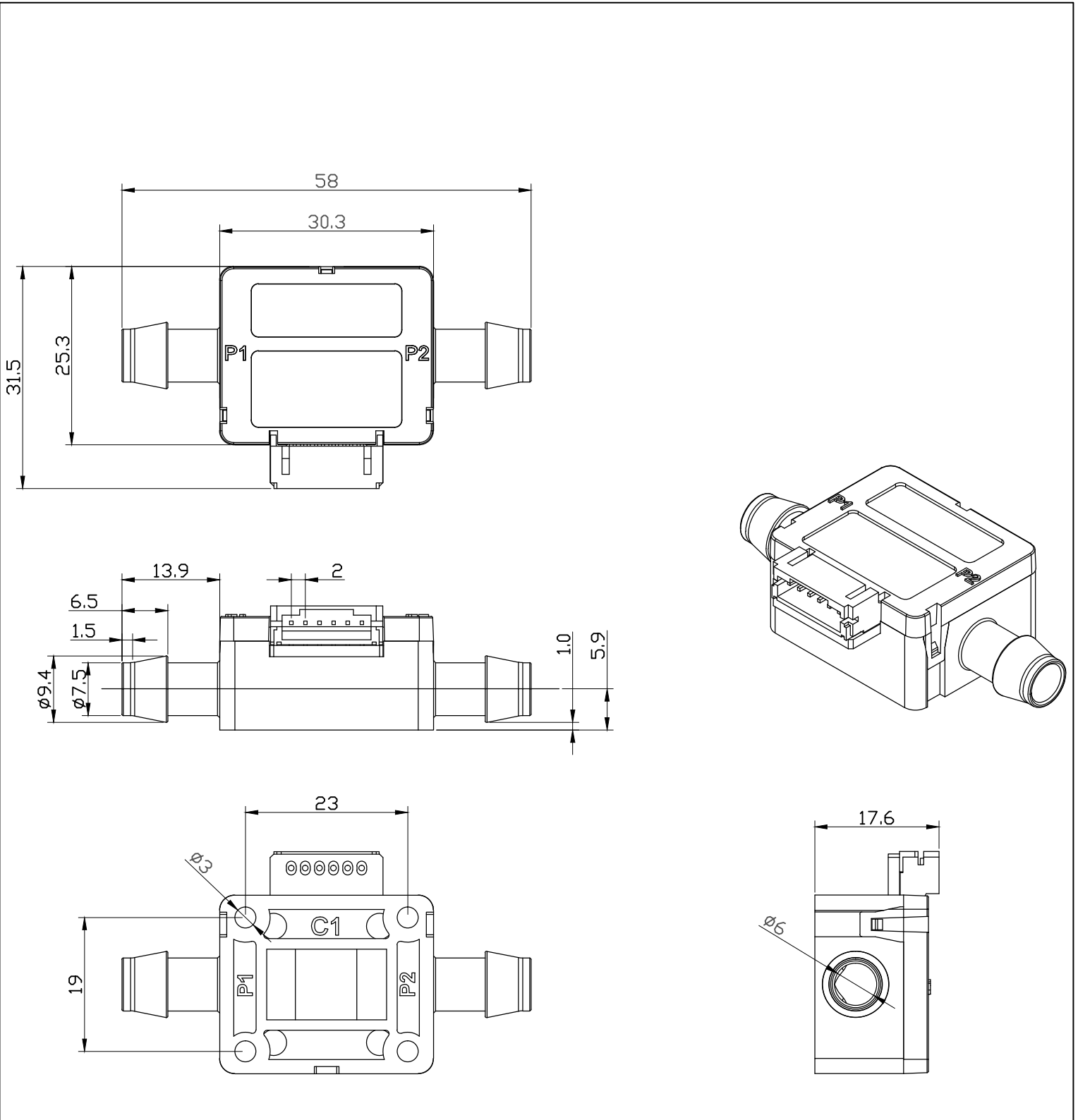

Package Revision History		
Date Created	Rev No.	Description
Nov 28, 2017	Rev 00	Initial Release

IMPORTANT NOTICE AND DISCLAIMER

RENESAS ELECTRONICS CORPORATION AND ITS SUBSIDIARIES (“RENESAS”) PROVIDES TECHNICAL SPECIFICATIONS AND RELIABILITY DATA (INCLUDING DATASHEETS), DESIGN RESOURCES (INCLUDING REFERENCE DESIGNS), APPLICATION OR OTHER DESIGN ADVICE, WEB TOOLS, SAFETY INFORMATION, AND OTHER RESOURCES “AS IS” AND WITH ALL FAULTS, AND DISCLAIMS ALL WARRANTIES, EXPRESS OR IMPLIED, INCLUDING, WITHOUT LIMITATION, ANY IMPLIED WARRANTIES OF MERCHANTABILITY, FITNESS FOR A PARTICULAR PURPOSE, OR NON-INFRINGEMENT OF THIRD PARTY INTELLECTUAL PROPERTY RIGHTS.

These resources are intended for developers skilled in the art designing with Renesas products. You are solely responsible for (1) selecting the appropriate products for your application, (2) designing, validating, and testing your application, and (3) ensuring your application meets applicable standards, and any other safety, security, or other requirements. These resources are subject to change without notice. Renesas grants you permission to use these resources only for development of an application that uses Renesas products. Other reproduction or use of these resources is strictly prohibited. No license is granted to any other Renesas intellectual property or to any third party intellectual property. Renesas disclaims responsibility for, and you will fully indemnify Renesas and its representatives against, any claims, damages, costs, losses, or liabilities arising out of your use of these resources. Renesas' products are provided only subject to Renesas' Terms and Conditions of Sale or other applicable terms agreed to in writing. No use of any Renesas resources expands or otherwise alters any applicable warranties or warranty disclaimers for these products.

(Rev.1.0 Mar 2020)

Corporate Headquarters

TOYOSU FORESIA, 3-2-24 Toyosu,
Koto-ku, Tokyo 135-0061, Japan
www.renesas.com

Contact Information

For further information on a product, technology, the most up-to-date version of a document, or your nearest sales office, please visit:
www.renesas.com/contact/

Trademarks

Renesas and the Renesas logo are trademarks of Renesas Electronics Corporation. All trademarks and registered trademarks are the property of their respective owners.