

☆Counter

- Single phase Input .
- Decimal Point Selectable .
- Dual Preset Counter .
- Divisor Range : 1 ~ 9999
- Multiplier Range : 0.001 ~9.999
- Increasement Counter or Decreasement Counter Selectable .

☆RPM or Line Speed Meter

- Pulses per Revolution Settable
- Sampling Time Settable .
- Decimal Point Auto Shift .



■ Specification

Type	Counter & RPM	Counter & Line Speed Meter
Model	SC-362M	SC-362Ma
Power Supply	110V / 220VAC ±20% , 50Hz	
DC Power Output	12VDC / 60mA Max.	
Unit	Revolutions per Minute	Meter per Minute
Sampling Time(S.T.)	1 ~ 99 Sec Settable	
Pules Per Revolution(PPR)	1 ~ 999 PPR Settable	
Decimal Point	Auto Shift	
Output Control	N / R / C Selectable , Range of Timer (t) : 0.01S ~99.99S	
Response Frequence	High Speed < 2.5K Hz ; Low Speed < 30Hz	
Divisor / Multiplier	Divisor Range : 1 ~ 9999 / Multiplier Range : 0.001 ~ 9.999	
Memory Method	EEP ROM	
ESD Resistance	Over 8KV	
Dielectric Strength	Over 2.5 KV / 1 min , Between Power And Each Terminal	
Isolation Strength	Over 500MΩ/500VDC , Between Power And Each Terminal	
Operating Temp./Hum.	-20°C ~ +80°C ; 35 ~ 85% RH	
Weight		

■ Connection Diagram & Dimension

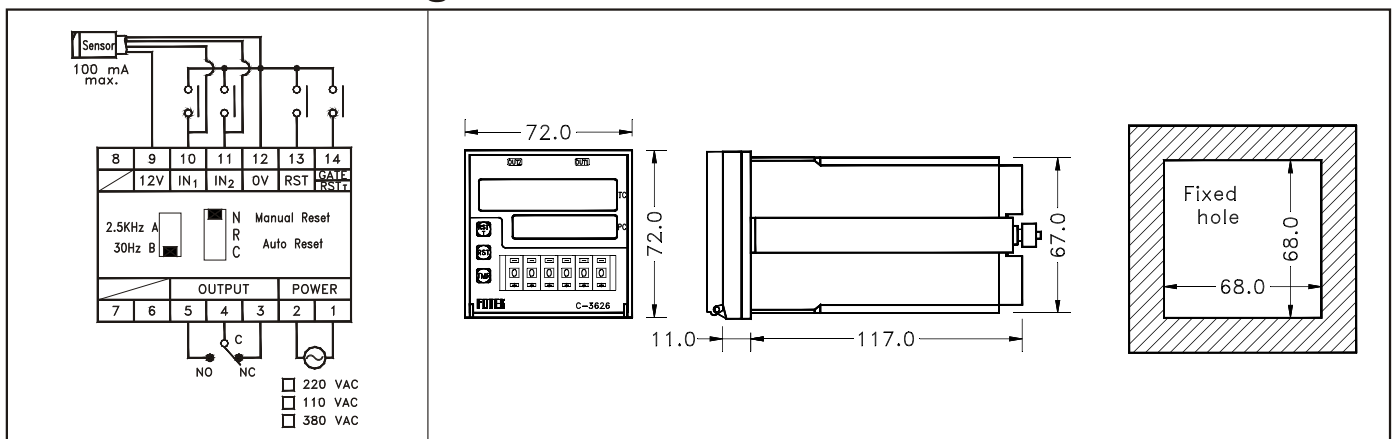

Setting of Parameter

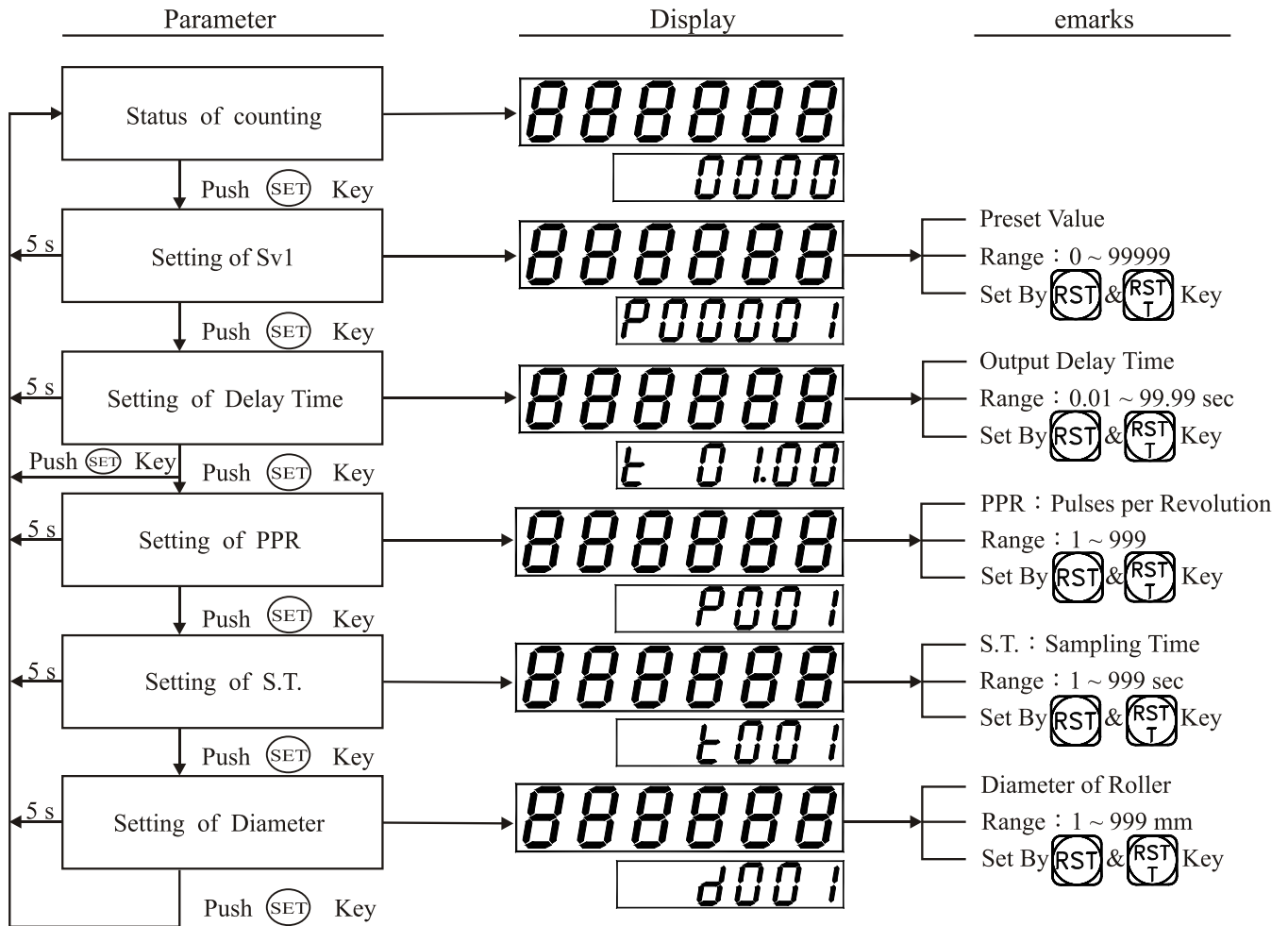

N / R / C Output Control

Single Preset Counter

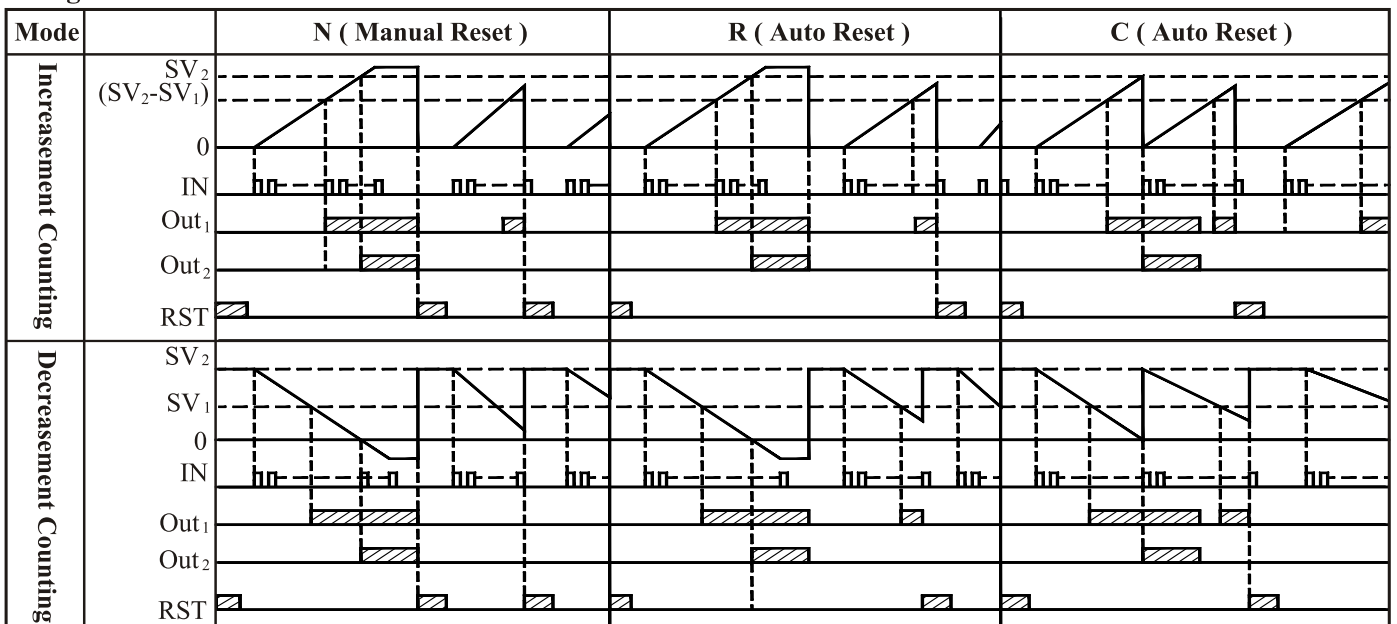

Remarks : SV₂ is Main Preset Value.