

Features

- ESD Protect for Low-Voltage Differential Signaling (LVDS) channels
- Protects four I/O lines
- Provide ESD protection for each channel to **IEC 61000-4-2 (ESD) ±30kV (air / contact)**
IEC 61000-4-4 (EFT) 80A (5/50ns)
IEC 61000-4-5 (Lightning) 15A (8/20µs)
- For operating voltage of 3.3V and below
- Low capacitance : 1.8pF typical
- Fast turn-on and Low clamping voltage
- Array of surge rated diodes with internal equivalent TVS diode
- Solid-state silicon-avalanche and active circuit triggering technology
- **Green Part**

Applications

- LVDS Interface
- USB2.0 Data Lines Protection
- Control Signal Lines Protection
- SIM Ports
- Monitors and Flat Panel Displays
- Notebook and PC Computers
- Ethernet Port: 10/100/1000 Mb/s
- Consumer Electronics
- Set Top Box

Description

AZ1013-04C is a high performance design which includes surge rated diode arrays to protect high speed data interfaces. The AZ1013-04C has been specifically designed to protect sensitive components, which are connected to data and transmission lines, from over-voltage caused by Electrostatic Discharging (ESD), Electrical Fast Transients (EFT), and Lightning.

AZ1013-04C is a unique design which includes surge rated, low capacitance steering diodes and a unique design of clamping cell which is an equivalent TVS diode in a single package.

transient conditions, the steering diodes direct the transient to either the internal ESD line or to ground line. The internal unique design of clamping cell prevents over-voltage on the internal ESD line and on the I/O line, which is protecting any downstream components.

AZ1013-04C may be used to meet the ESD immunity requirements of IEC 61000-4-2, Level 4 (±15kV air, ±8kV contact discharge).

Circuit Diagram

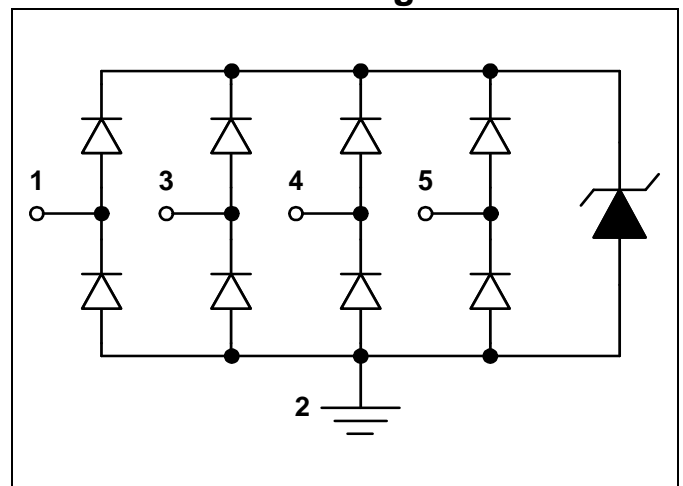

Pin Configuration

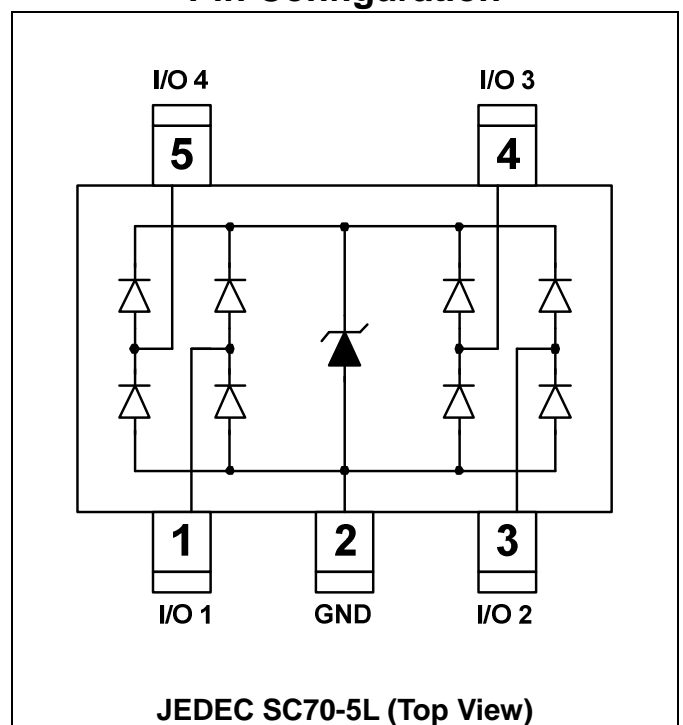



SPECIFICATIONS

ABSOLUTE MAXIMUM RATINGS			
PARAMETER	SYMBOL	RATING	UNITS
Peak Pulse Current (tp = 8/20μs)	I _{PP}	15	A
Operating Supply Voltage (I/O - GND)	V _{DC}	(GND – 0.5) to 3.6	V
ESD per IEC 61000-4-2 (Air)	V _{ESD}	±30	kV
ESD per IEC 61000-4-2 (Contact)		±30	
Lead Soldering Temperature	T _{SOL}	260 (10 sec.)	°C
Operating Temperature	T _{OP}	-55 to +125	°C
Storage Temperature	T _{STO}	-55 to +150	°C

ELECTRICAL CHARACTERISTICS						
PARAMETER	SYMBOL	CONDITIONS	MIN	TYP	MAX	UNITS
Reverse Stand-Off Voltage	V _{RWM}	Pin-1, -3, -4, -5 to Pin-2, T=25 °C.			3.3	V
Channel Leakage Current	I _{CH-Leak}	V _{RWM} = 3.3V, T=25 °C. Pin-1, -3, -4, -5 to Pin-2.			1.0	μA
Reverse Breakdown Voltage	V _{BV}	I _{BV} = 1mA, T=25 °C. Pin-1, -3, -4, -5 to Pin-2.	4.5			V
Forward Voltage	V _F	I _F = 15mA, T=25 °C, Pin-2 to Pin-1, -3, -4, -5.		0.8	1.2	V
ESD Clamping Voltage (Note. 1)	V _{clamp}	IEC 61000-4-2 +8kV (I _{TLP} = 16A), Contact mode, T=25 °C, I/O pin to Ground.		7.8		V
Lightning Clamping Voltage	V _{lightning}	I _{PP} =5A, tp=8/20μs, T=25°C, Any Channel pin to Ground.		5.7		V
Channel Input Capacitance	C _{IN}	V _{pin2} =0V, V _{IN} =1.65V, f =1MHz, T=25°C, Any Channel pin to Ground.		1.8	2.3	pF
Channel to Channel Input Capacitance	C _{CROSS}	V _{pin2} =0V, V _{IN} =1.65V, f =1MHz, T=25°C, Between Channel pins.		0.25	0.5	pF

Note 1: ESD Clamping Voltage was measured by Transmission Line Pulsing (TLP) System.

TLP conditions: Z₀= 50Ω, t_p= 100ns, t_r= 1ns.



Typical Characteristics

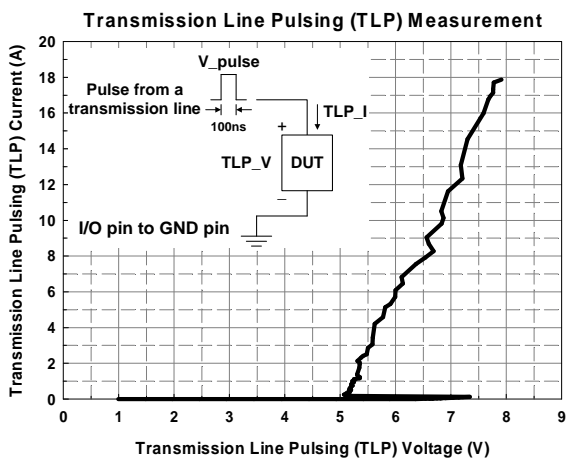
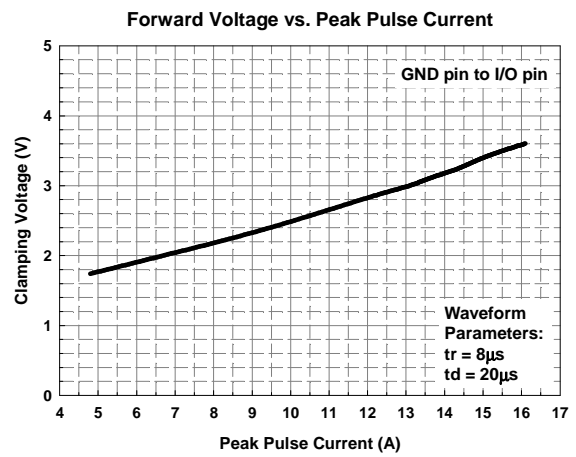
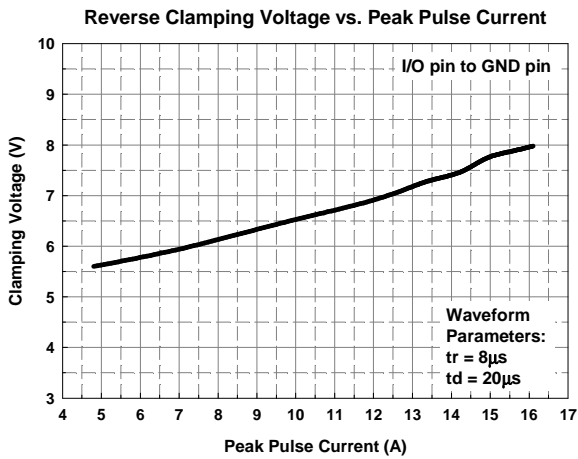
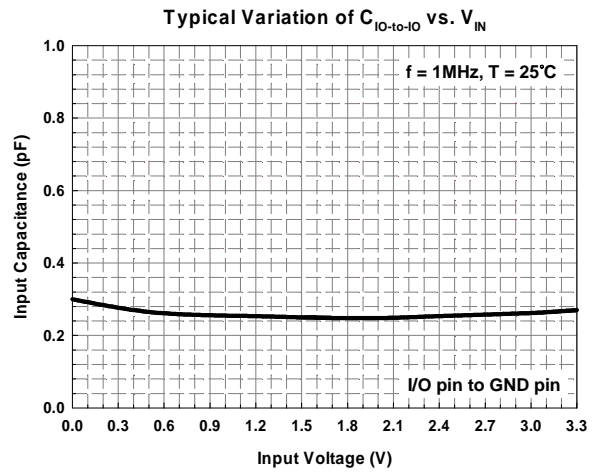
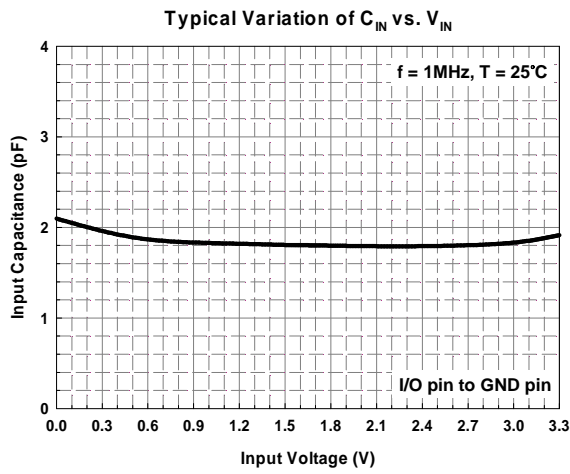

Mechanical Details

SC70-5L

PACKAGE DIAGRAMS

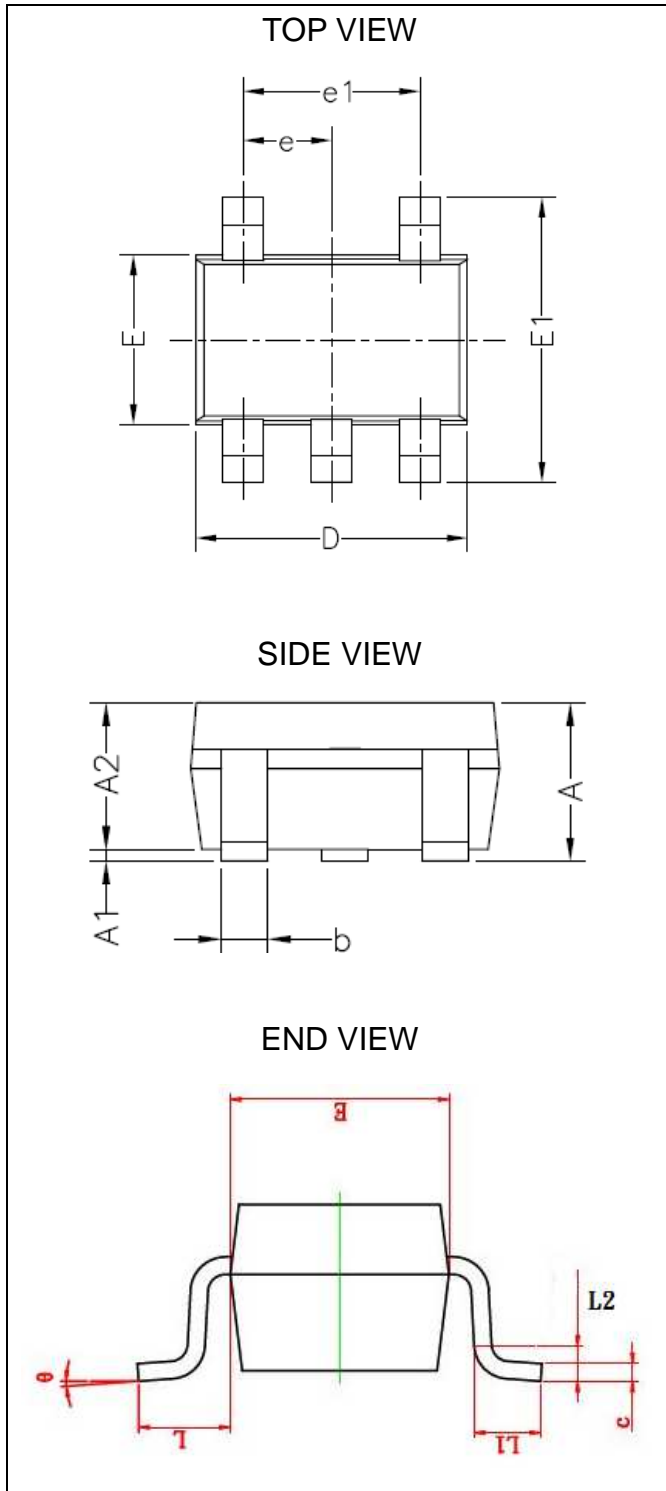

PACKAGE DIMENSIONS

Symbol	Millimeters		Inches	
	MIN.	MAX.	MIN.	MAX.
A	0.9	1.1	0.035	0.043
A1	0	0.1	0	0.004
A2	0.875	1	0.035	0.04
b	0.15	0.4	0.006	0.016
C	0.08	0.15	0.003	0.006
D	1.9	2.2	0.076	0.087
e	0.65 BSC		0.026 BSC	
e1	1.2	1.4	0.047	0.055
E	1.15	1.35	0.045	0.053
E1	2	2.45	0.008	0.096
L	0.525 REF		0.021 REF	
L1	0.26	0.46	0.01	0.018
L2	0.2 REF		0.008 REF	
θ	0°	8°	0°	8°

Note:

1. All dimensions are in millimeters, and the dimensions in inches are for reference only.
2. 1mm = 40 mils = 0.04 inches.

LAND LAYOUT

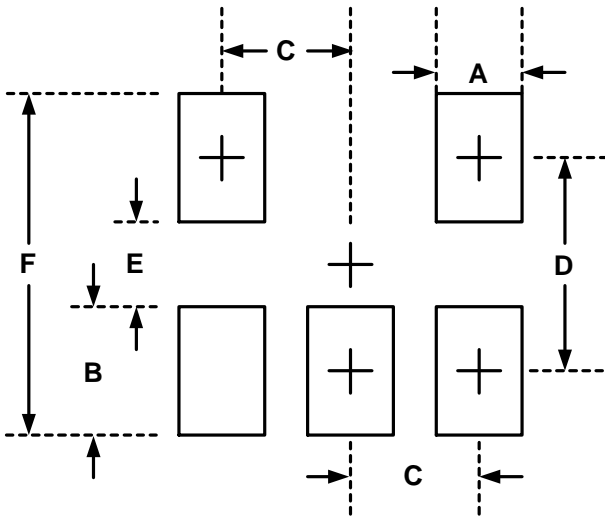

Dimensions		
Index	Millimeter	Inches
A	0.40	0.016
B	0.85	0.033
C	0.65	0.026
D	1.85	0.073
E	1.00	0.039
F	2.70	0.106

Notes:

This LAND LAYOUT is for reference purposes only. Please consult your manufacturing partners to ensure your company's PCB design guidelines are met.

MARKING CODE

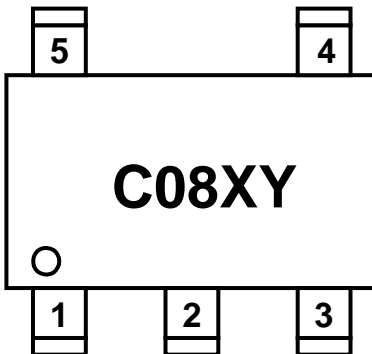

C08 = Device Code
X = Date Code
Y = Control Code

Part Number	Marking Code
AZ1013-04C (Green Part)	C08XY

Note. Green means Pb-free, RoHS, and Halogen free compliant.

Ordering Information

PN#	Material	Type	Reel size	MOQ	MOQ/internal box	MOQ/carton
AZ1013-04C.R7G	Green	T/R	7 inch	3,000/reel	4 reel=12,000/box	6 box=72,000/carton



Revision History

Revision	Modification Description
Revision 2014/08/06	Preliminary Release.
Revision 2015/03/19	Update the Operating Temperature from 85°C to 125°C.
Revision 2016/12/30	Formal Release.