

## Sensitive and Standard SCRs, 8A

### Main Features

Symbol	Value	Unit
$I_{T(RMS)}$	8	A
$V_{DRM}/V_{RRM}$	600 to 1000	V
$I_{GT}$	0.2 to 15	mA

### DESCRIPTION

Available either in sensitive or standard gate triggering levels, the 8A SCR series is suitable to fit all modes of control found in applications such as overvoltage crowbar protection, motor control circuits in power tools and kitchen aids, inrush current limiting circuits, capacitive discharge ignition and voltage regulation circuits.

Available in through-hole or surface-mount packages, they provide an optimized performance in a limited space.

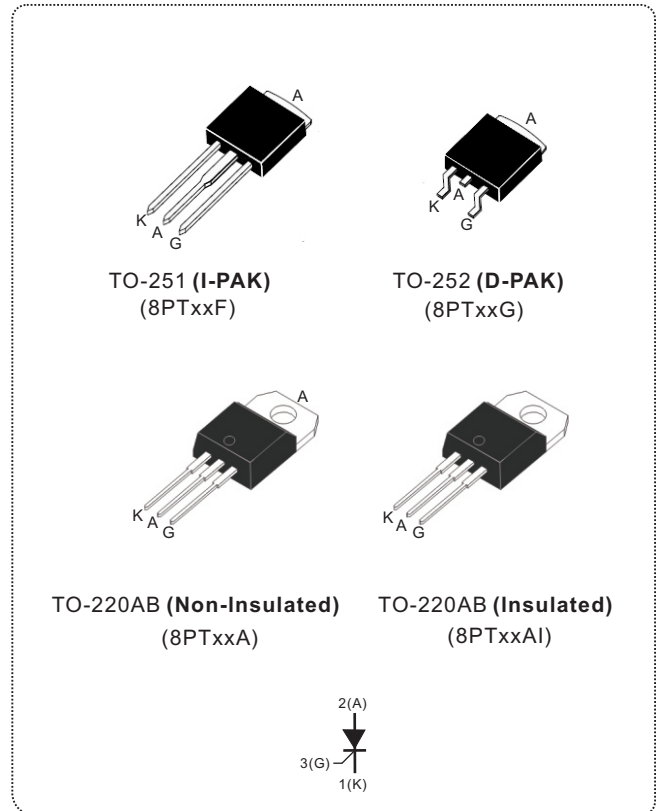

### ABSOLUTE MAXIMUM RATINGS

PARAMETER	SYMBOL	TEST CONDITIONS		VALUE	UNIT
RMS on-state current full sine wave (180° conduction angle)	$I_{T(RMS)}$	TO-251/TO-252/TO-220AB	$T_c = 110^\circ\text{C}$	8	A
		TO-220AB insulated	$T_c = 100^\circ\text{C}$		
Average on-state current (180° conduction angle)	$I_{T(AV)}$	TO-251/TO-252/TO-220AB	$T_c = 110^\circ\text{C}$	5.1	A
		TO-220AB insulated	$T_c = 100^\circ\text{C}$		
Non repetitive surge peak on-state current (full cycle, $T_j$ initial = $25^\circ\text{C}$ )	$I_{TSM}$	F = 50 Hz	t = 20 ms	95	A
		F = 60 Hz	t = 16.7 ms	100	
$I^2t$ Value for fusing	$I^2t$	$t_p = 10$ ms		45	$\text{A}^2\text{s}$
Critical rate of rise of on-state current $I_G = 2 \times I_{GT}$ , $t_r \leq 100\text{ns}$	$di/dt$	F = 60 Hz	$T_j = 125^\circ\text{C}$	50	$\text{A}/\mu\text{s}$
Peak gate current	$I_{GM}$	$T_p = 20 \mu\text{s}$	$T_j = 125^\circ\text{C}$	4	A
Average gate power dissipation	$P_{G(AV)}$	$T_j = 125^\circ\text{C}$		1	W
Storage temperature range	$T_{stg}$			- 40 to + 150	°C
Operating junction temperature range	$T_j$			- 40 to + 125	

STANDARD ELECTRICAL SPECIFICATIONS (T <sub>J</sub> = 25 °C, unless otherwise specified)							
SYMBOL	TEST CONDITIONS			8PTxxxx		Unit	
				T	-		
I <sub>GT</sub>	V <sub>D</sub> = 12 V, R <sub>L</sub> = 30Ω			Min.	0.5	2	mA
				Max.	5	15	
V <sub>GT</sub>				Max.	1.3		V
V <sub>GD</sub>	V <sub>D</sub> = V <sub>DRM</sub> , R <sub>L</sub> = 3.3KΩ	T <sub>J</sub> = 125°C		Min.	0.2		V
I <sub>H</sub>	I <sub>T</sub> = 100 mA, gate open			Max.	25	30	mA
I <sub>L</sub>	I <sub>G</sub> = 1.2 I <sub>GT</sub>			Max.	30	70	mA
dV/dt	V <sub>D</sub> = 67% V <sub>DRM</sub> , gate open	T <sub>J</sub> = 125°C		Min.	50	150	V/μs
V <sub>TM</sub>	I <sub>TM</sub> = 16A, t <sub>p</sub> = 380 μs	T <sub>J</sub> = 25°C		Max.	1.6		V
V <sub>to</sub>	Threshold voltage		T <sub>J</sub> = 125°C	Max.	0.85		V
R <sub>d</sub>	Dynamic resistance		T <sub>J</sub> = 125°C	Max.	46		mΩ
I <sub>DRM</sub> I <sub>RRM</sub>	V <sub>DRM</sub> = V <sub>RRM</sub>		T <sub>J</sub> = 25°C	Max.	5		μA
			T <sub>J</sub> = 125°C		1		mA

SENSITIVE ELECTRICAL CHARACTERISTICS (T <sub>J</sub> = 25 °C, unless otherwise specified)							
SYMBOL	TEST CONDITIONS			8PTxxxx-S	Unit		
I <sub>GT</sub>	V <sub>D</sub> = 12 V, R <sub>L</sub> = 140Ω			Max.	200	μA	
				V <sub>GT</sub>	Max.	0.8	V
V <sub>GD</sub>	V <sub>D</sub> = V <sub>DRM</sub> , R <sub>L</sub> = 3.3KΩ, R <sub>GK</sub> = 220Ω	T <sub>J</sub> = 125°C		Min.	0.1	V	
V <sub>RG</sub>	I <sub>RG</sub> = 10 μA			Min.	8	V	
I <sub>H</sub>	I <sub>T</sub> = 50 mA, R <sub>GK</sub> = 1 KΩ			Max.	5	mA	
I <sub>L</sub>	I <sub>G</sub> = 1 mA, R <sub>GK</sub> = 1 KΩ			Max.	6	mA	
dV/dt	V <sub>D</sub> = 67% V <sub>DRM</sub> , R <sub>GK</sub> = 220Ω	T <sub>J</sub> = 125°C		Min.	5	V/μs	
V <sub>TM</sub>	I <sub>TM</sub> = 16A, t <sub>p</sub> = 380 μs	T <sub>J</sub> = 25°C		Max.	1.6	V	
V <sub>to</sub>	Threshold voltage		T <sub>J</sub> = 125°C	Max.	0.85	V	
R <sub>d</sub>	Dynamic resistance		T <sub>J</sub> = 125°C	Max.	46	mΩ	
I <sub>DRM</sub> I <sub>RRM</sub>	V <sub>DRM</sub> = V <sub>RRM</sub> , R <sub>GK</sub> = 220Ω		T <sub>J</sub> = 25°C	Max.	5		μA
			T <sub>J</sub> = 125°C		1		mA

THERMAL RESISTANCE						
SYMBOL	Parameter			VALUE	UNIT	
R <sub>th(j-c)</sub>	Junction to case (DC)			IPAK/DPAK/TO-220AB	1.3	°C/W
				TO-220AB insulated	4.6	
R <sub>th(j-a)</sub>	Junction to ambient (DC)			S = 0.5 cm <sup>2</sup>	70	°C/W
				D-PAK		
				I-PAK	100	
			TO-220AB, TO-220AB insulated	60		

S=Copper surface under tab

PRODUCT SELECTOR					
PART NUMBER	VOLTAGE (xx)			SENSITIVITY	PACKAGE
	600 V	800 V	1000 V		
8PTxxA-S/8PTxxAI-S	V	V	V	200 $\mu$ A	TO-220AB
8PTxxA-T/8PTxxAI-T	V	V	V	0.5~5 mA	TO-220AB
8PTxxA/8PTxxAI	V	V	V	2~15 mA	TO-220AB
8PTxxF-S	V	V	V	200 $\mu$ A	I-PAK
8PTxxF-T	V	V	V	0.5~5 mA	I-PAK
8PTxxF	V	V	V	2~15 mA	I-PAK
8PTxxG-S	V	V	V	200 $\mu$ A	D-PAK
8PTxxG-T	V	V	V	0.5~5 mA	D-PAK
8PTxxG	V	V	V	2~15 mA	D-PAK

ORDERING INFORMATION					
ORDERING TYPE	MARKING	PACKAGE	WEIGHT	BASE Q'TY	DELIVERY MODE
8PTxxA-y	8PTxxA-y	TO-220AB	2.0g	50	Tube
8PTxxAI-y	8PTxxAI-y	TO-220AB (insulated)	2.3g	50	Tube
8PTxxF-y	8PTxxF-y	TO-251(I-PAK)	0.40g	80	Tube
8PTxxG-y	8PTxxG-y	TO-252(D-PAK)	0.38g	80	Tube

Note: xx = voltage, y = sensitivity

ORDERING INFORMATION SCHEME	
<p><b>8 PT 06 AI - S</b></p>	<p><b>Current</b> 8 = 8A, <math>I_{T(RMS)}</math></p> <p><b>SCR series</b></p> <p><b>Voltage Code</b> 06 = 600V 08 = 800V 10 = 1000V</p> <p><b>Package type</b> A = TO-220AB (non-insulated) AI = TO-220AB (insulated) F = TO-251 (IPAK) G = TO-252 (DPAK)</p> <p><b><math>I_{GT}</math> Sensitivity</b> S = 70~200 <math>\mu</math>A T = 0.5~5 mA Blank = 2~15 mA</p>

Fig.1 Maximum average power dissipation versus average on-state current

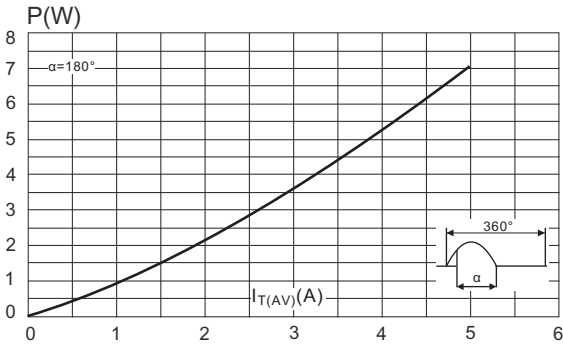

Fig.2 Average and DC on-state current versus case temperature

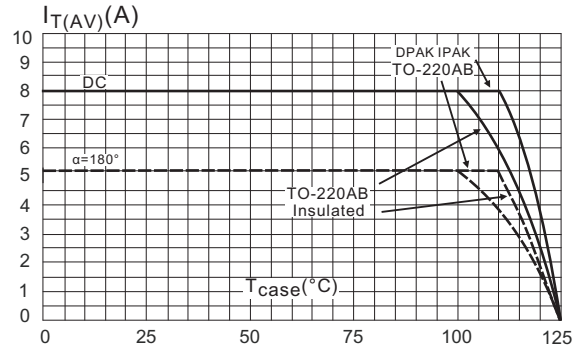

Fig.3 Average and DC on-state current versus ambient temperature

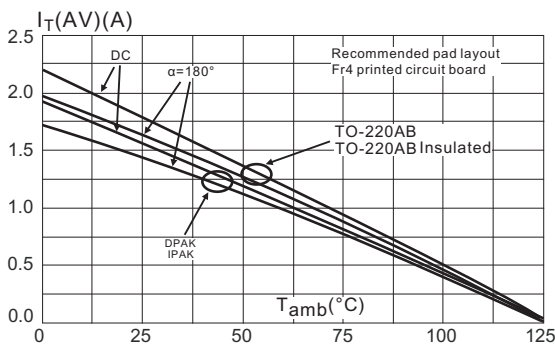

Fig.4 Relative variation of thermal impedance junction to case versus pulse duration

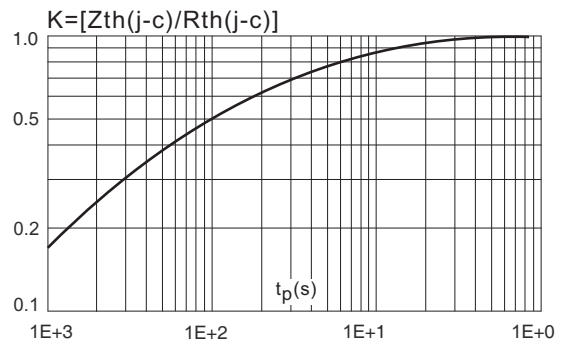

Fig.5 Relative variation of thermal impedance junction to ambient versus pulse duration

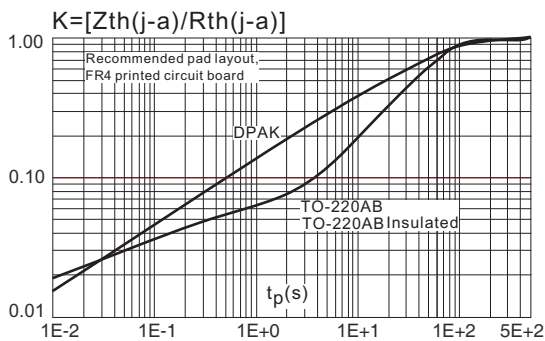

Fig.6 Relative variation of gate trigger current and holding current versus junction temperature for I<sub>GT</sub>=200µA

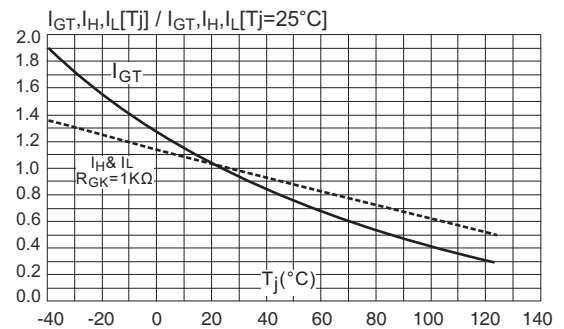

Fig.7 Relative variation of gate trigger and holding current versus junction temperature

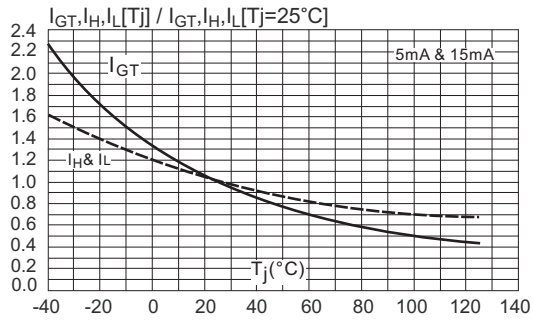

Fig.8 Relative variation of holding current versus gate-cathode resistance (typical values)

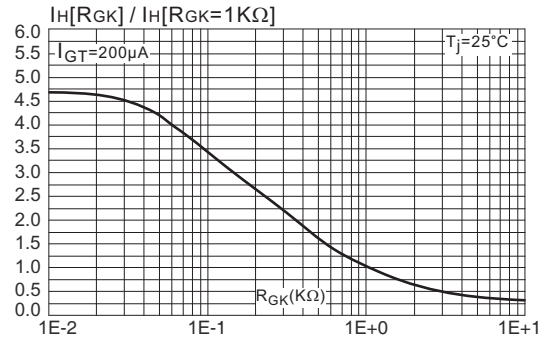

Fig.9 Relative variation of dV/dt immunity versus gate-cathode resistance (typical values) for I\_G=200μA

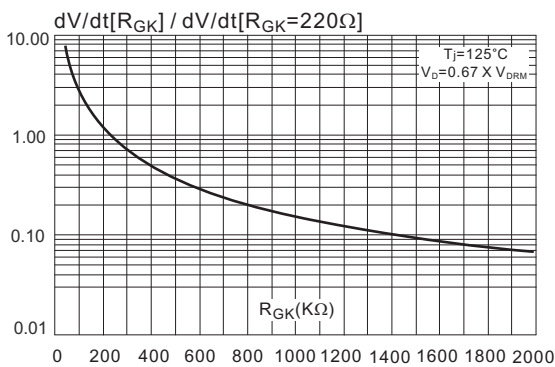

Fig.10 Relative variation of dV/dt immunity versus gate-cathode capacitance (typical values) for I\_G=200μA

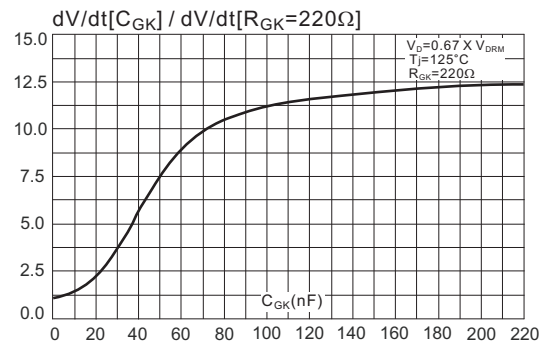

Fig.11 Surge peak on-state current versus number of cycles

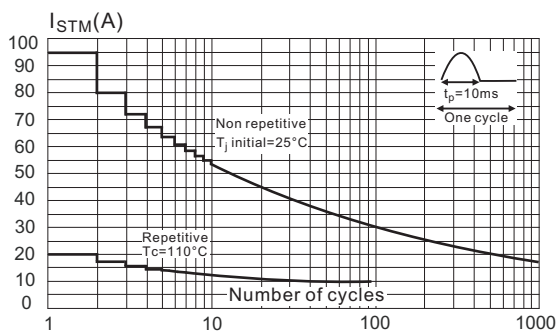

Fig.12 Non-repetitive surge peak on-state current and corresponding values of I²t

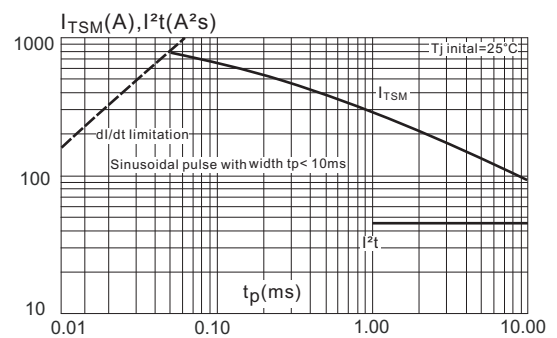

Fig.13 On-state characteristics (maximum values)

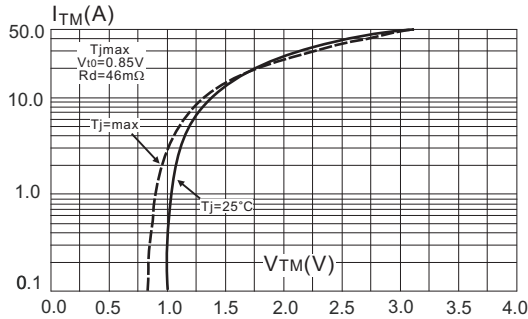
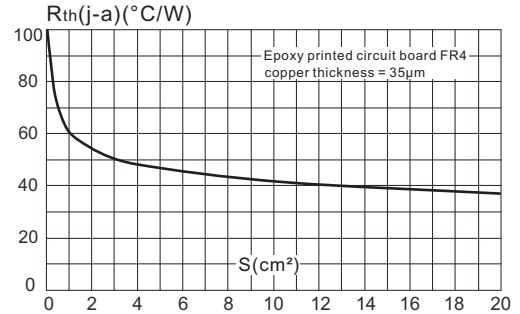
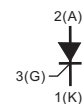
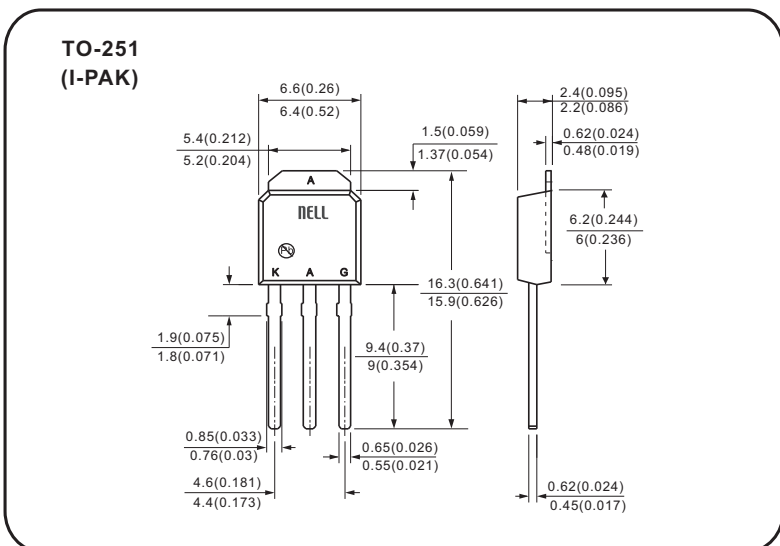
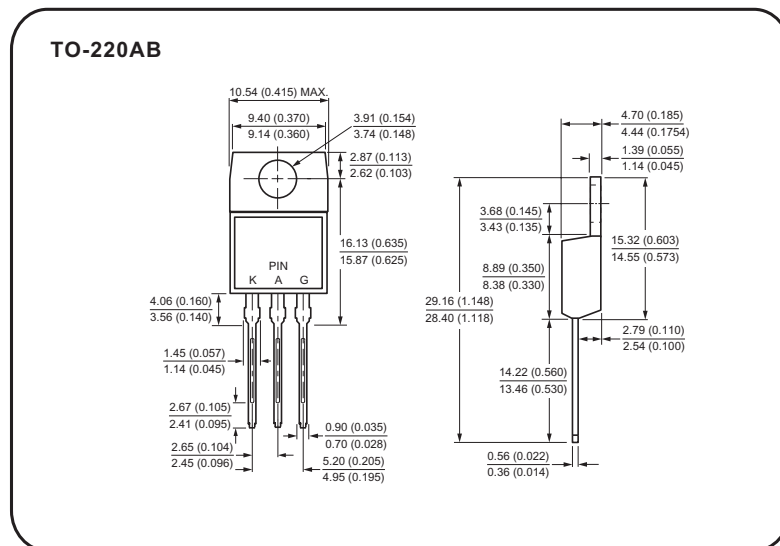

Fig.14 Thermal resistance junction to ambient versus copper surface under tab (DPAK)



## Case Style



All dimensions in millimeters(inches)

### Case Style

**TO-252  
(D-PAK)**

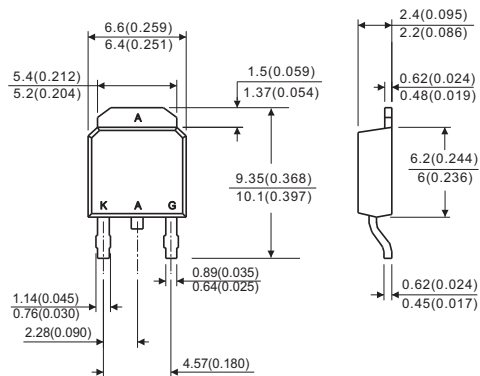

All dimensions in millimeters(inches)

