

Figure 2. LRS1341/LRS1342 Block Diagram

Table 1. Pin Descriptions

PIN	DESCRIPTION	TYPE
A <sub>0</sub> to A <sub>16</sub>	Address Inputs (Common)	Input
F-A <sub>17</sub> to F-A <sub>19</sub>	Address Inputs (Flash)	Input
F- $\overline{CE}$	Chip Enable Input (Flash)	Input
S- $\overline{CE}_1$ , S-CE <sub>2</sub>	Chip Enable Inputs (SRAM)	Input
F- $\overline{WE}$	Write Enable Input (Flash)	Input
S- $\overline{WE}$	Write Enable Input (SRAM)	Input
F- $\overline{OE}$	Output Enable Input (Flash)	Input
S- $\overline{OE}$	Output Enable Input (SRAM)	Input
S- $\overline{LB}$	SRAM Byte Enable Input (DQ <sub>0</sub> to DQ <sub>7</sub> )	Input
S- $\overline{UB}$	SRAM Byte Enable Input (DQ <sub>8</sub> to DQ <sub>15</sub> )	Input
F- $\overline{RP}$	Reset/Power Down (Flash) Block erase and Word Write: V <sub>IH</sub> or V <sub>HH</sub> Read: V <sub>IH</sub> or V <sub>HH</sub> Reset/Power Down: V <sub>IL</sub>	Input
F- $\overline{WP}$	Write Protect (Flash) Two Boot Blocks Locked: V <sub>IL</sub> (with F- $\overline{RP}$ = V <sub>HH</sub> ) Erase of Write can operate to all blocks)	Input
F-RY/ $\overline{BY}$	Ready/Busy (Flash) During an Erase or Write operation: V <sub>OL</sub> Block Erase and Word Write Suspend: HIGH-Z Deep Power Down: V <sub>OH</sub>	Output
DQ <sub>0</sub> to DQ <sub>15</sub>	Data Input/Outputs (Common)	Input/Output
F-V <sub>CC</sub>	Power Supply (Flash)	Power
S-V <sub>CC</sub>	Power Supply (SRAM)	Power
F-V <sub>PP</sub>	Write, Erase Power Supply (Flash) Block Erase and Word Write: F-V <sub>PP</sub> = V <sub>PPLK</sub> All Blocks Locked: F-V <sub>PP</sub> < V <sub>PPLK</sub>	Power
GND	Ground (Common)	Power
NC	No Connection	—
T <sub>1</sub> to T <sub>5</sub>	Test Pins (Should be Open)	—

Table 2. Truth Table<sup>1</sup>

FLASH	SRAM	F-CE	F-RP	F-OE	F-WE	S-CE <sub>1</sub>	S-CE <sub>2</sub>	S-OE	S-WE	S-LB	S-UB	DQ <sub>0</sub> - DQ <sub>7</sub>	DQ <sub>8</sub> - DQ <sub>15</sub>	NOTES
Read	Standby	L	H	L	H	See Note 4		X	X	See Note 4		D <sub>OUT</sub>		2, 3
Output Disable	Standby	L	H	H	H			X	X			HIGH-Z		3
Write	Standby	L	H	H	L			X	X			D <sub>IN</sub>		2, 3, 5, 6
Standby	Read	H	H	X	X	L	H	L	H	See Note 7				
	Output Disable	H	H	X	X	L	H	H	H	X	X	HIGH-Z		
		H	H	X	X	L	H	X	X	H	H	HIGH-Z		
Write	H	H	X	X	L	H	L	L	See Note 7					
Reset/Power Down	Read	X	L	X	X	L	H	L	H	See Note 7				
	Output Disable	X	L	X	X	L	H	H	H	X	X	HIGH-Z		
		X	L	X	X	L	H	X	X	H	H	HIGH-Z		
Write	X	L	X	X	L	H	L	L	See Note 7					
Standby	Standby	H	H	X	X	See Note 4		X	X	See Note 4		HIGH-Z		3
Reset/Power Down	Standby	X	L	X	X			X	X			HIGH-Z		3

**NOTES:**

- L = V<sub>IL</sub>, H = V<sub>IH</sub>, X = H or L. Refer to DC Characteristics.
- Refer to the 'Flash Memory Command Definition' section for valid D<sub>IN</sub> during a write operation.
- F- $\overline{WP}$  set to V<sub>IL</sub> or V<sub>IH</sub>.
- SRAM standby mode. See Table 2a.
- Command writes involving block erase or word write are reliably executed when F-V<sub>PP</sub> = V<sub>PPH</sub> and F-V<sub>CC</sub> = 2.7 V to 3.6 V. Block erase or word write with V<sub>IH</sub> < RP < V<sub>HH</sub> produce spurious results and should not be attempted.
- Never hold F- $\overline{OE}$  LOW and F- $\overline{WE}$  LOW at the same time.
- S-LB, S-UB control mode. See Table 2b.

Table 2a.

MODE	PINS			
	S-CE <sub>1</sub>	S-CE <sub>2</sub>	S-LB	S-UB
Standby (SRAM)	H	X	X	X
	X	L	X	X
	X	X	H	H

Table 2b.

MODE (SRAM)	PINS			
	S-LB	S-UB	DQ <sub>0</sub> - DQ <sub>7</sub>	DQ <sub>8</sub> - DQ <sub>15</sub>
Read/Write	L	L	D <sub>OUT</sub> /D <sub>IN</sub>	D <sub>OUT</sub> /D <sub>IN</sub>
	L	H	D <sub>OUT</sub> /D <sub>IN</sub>	HIGH-Z
	H	L	HIGH-Z	D <sub>OUT</sub> /D <sub>IN</sub>

Table 3. Command Definition for Flash Memory<sup>1</sup>

COMMAND	BUS CYCLES REQUIRED	FIRST BUS CYCLE			SECOND BUS CYCLE			NOTES
		OPERATION <sup>2</sup>	ADDRESS <sup>3</sup>	DATA <sup>3</sup>	OPERATION <sup>2</sup>	ADDRESS <sup>3</sup>	DATA <sup>3</sup>	
Read Array/Reset	1	Write	XA	FFH				
Read Identifier Codes	≥ 2	Write	XA	90H	Read	IA	ID	4
Read Status Register	2	Write	XA	70H	Read	XA	SRD	
Clear Status Register	1	Write	XA	50H				
Block Erase	2	Write	BA	20H	Write	BA	D0H	5
Word Write	2	Write	WA	40H or 10H	Write	WA	WD	5
Block Erase and Word Write Suspend	1	Write	XA	B0H				5
Block Erase and Word Write Resume	1	Write	XA	D0H				5

**NOTES:**

- Commands other than those shown in table are reserved by SHARP for future device implementations and should not be used.
  - BUS operations are defined in Table 2.
  - XA = Any valid address within the device;  
IA = Identifier code address;  
BA = Address within the block being erased;
  - See Table 4 for Identifier Codes.
  - See Table 5 for Write Protection Alternatives.
- WA = Address of memory location to be written;  
SRD = Data read from status register, see Table 6;  
WD = Data to be written at location WA. Data is latched on the rising edge of F- $\overline{WE}$  or F- $\overline{CE}$  (whichever goes high first);  
ID = Data read from identifier codes.

Table 4. Identifier Codes

CODES	ADDRESS (A <sub>0</sub> - A <sub>18</sub> )	LRS1341 DATA (DQ <sub>0</sub> - DQ <sub>7</sub> )	LRS1342 DATA (DQ <sub>0</sub> - DQ <sub>7</sub> )
Manufacture Code	00000H	B0H	B0H
Device Code	00001H	48H	49H

Table 5. Write Protection Alternatives

OPERATION	F-V <sub>PP</sub>	F-R <sub>P</sub>	F-W <sub>P</sub>	EFFECT
Block Erase or Word Write	V <sub>IL</sub>	X	X	All blocks locked
	> V <sub>PPLK</sub>	V <sub>IL</sub>	X	All blocks locked
		V <sub>HH</sub>	X	All blocks unlocked
		V <sub>IH</sub>	V <sub>IL</sub>	Two boot blocks locked
		V <sub>IH</sub>	V <sub>IH</sub>	All blocks unlocked

Table 6. Status Register Definition

WSMS	ESS	ES	WWS	VPPS	WWSS	DPS	R
7	6	5	4	3	2	1	0

SR.7 = Write State Machine Status (WSMS)

- 1 = Ready
- 0 = Busy

SR.6 = Erase Suspend Status (ESS)

- 1 = Block Erase Suspended
- 0 = Block Erase in Progress/Completed

SR.5 = Erase Status (ES)

- 1 = Error in Block Erasure
- 0 = Successful Block Erase

SR.4 = Word Write Status (WWS)

- 1 = Error in Word Write
- 0 = Successful Word Write

SR.3 = V<sub>PP</sub> Status (VPPS)

- 1 = F-V<sub>PP</sub> LOW Detect, Operation Abort
- 0 = F-V<sub>PP</sub> Okay

SR.2 = Word Write Suspend Status (WWSS)

- 1 = Word Write Suspended
- 0 = Word Write in Progress/Completed

SR.1 = Device Protect Status (DPS)

- 1 = F-W<sub>P</sub> and/or F-R<sub>P</sub> Lock Detected,  
Operation Abort
- 0 = Unlock

SR.0 = Reserved for future enhancements (R)

**NOTES:**

1. Check RY/ $\overline{\text{BY}}$  or SR.7 to determine block erase or word write completion. SR.6 - SR.0 are invalid while SR.7 = 0.
2. If both SR.5 and SR.4 are '1's after a block erase attempt, an improper command sequence was entered.
3. SR.3 does not provide a continuous indication of F-V<sub>PP</sub> level. The WSM interrogates and indicates the F-V<sub>PP</sub> level only after Block Erase or Word Write command sequences. SR.3 is not guaranteed to report accurate feedback only when F-V<sub>PP</sub> ≠ V<sub>PPH1</sub>, V<sub>PPH2</sub>.
4. The WSM interrogates the F-W<sub>P</sub> and F-R<sub>P</sub> only after Block Erase or Word Write command sequences. It informs the system, depending on the attempted operation, if the F-W<sub>P</sub> is not V<sub>IH</sub> or F-R<sub>P</sub> is not V<sub>HH</sub>.
5. SR.0 is reserved for future use and should be masked out when polling the status register.

MEMORY MAPS

[A <sub>0</sub> - A <sub>19</sub> ]		
FFFF		
F8000	32K-WORD MAIN BLOCK	30
F7FFF	32K-WORD MAIN BLOCK	29
F0000		
EFFFF	32K-WORD MAIN BLOCK	28
E8000		
E7FFF	32K-WORD MAIN BLOCK	27
E0000		
DFFFF	32K-WORD MAIN BLOCK	26
D8000		
D7FFF	32K-WORD MAIN BLOCK	25
D0000		
CFFFF	32K-WORD MAIN BLOCK	24
C8000		
C7FFF	32K-WORD MAIN BLOCK	23
C0000		
BFFFF	32K-WORD MAIN BLOCK	22
B8000		
B7FFF	32K-WORD MAIN BLOCK	21
B0000		
AFFFF	32K-WORD MAIN BLOCK	20
A8000		
A7FFF	32K-WORD MAIN BLOCK	19
A0000		
9FFFF	32K-WORD MAIN BLOCK	18
98000		
97FFF	32K-WORD MAIN BLOCK	17
90000		
8FFFF	32K-WORD MAIN BLOCK	16
88000		
87FFF	32K-WORD MAIN BLOCK	15
80000		
7FFFF	32K-WORD MAIN BLOCK	14
78000		
77FFF	32K-WORD MAIN BLOCK	13
70000		
6FFFF	32K-WORD MAIN BLOCK	12
68000		
67FFF	32K-WORD MAIN BLOCK	11
60000		
5FFFF	32K-WORD MAIN BLOCK	10
58000		
57FFF	32K-WORD MAIN BLOCK	9
50000		
4FFFF	32K-WORD MAIN BLOCK	8
48000		
47FFF	32K-WORD MAIN BLOCK	7
40000		
3FFFF	32K-WORD MAIN BLOCK	6
38000		
37FFF	32K-WORD MAIN BLOCK	5
30000		
2FFFF	32K-WORD MAIN BLOCK	4
28000		
27FFF	32K-WORD MAIN BLOCK	3
20000		
1FFFF	32K-WORD MAIN BLOCK	2
18000		
17FFF	32K-WORD MAIN BLOCK	1
10000		
0FFFF	32K-WORD MAIN BLOCK	0
08000		
07FFF	4K-WORD PARAMETER BOOT BLOCK	5
07000		
06FFF	4K-WORD PARAMETER BOOT BLOCK	4
06000		
05FFF	4K-WORD PARAMETER BOOT BLOCK	3
05000		
04FFF	4K-WORD PARAMETER BOOT BLOCK	2
04000		
03FFF	4K-WORD PARAMETER BOOT BLOCK	1
03000		
02FFF	4K-WORD PARAMETER BOOT BLOCK	0
02000		
01FFF	4K-WORD BOOT BLOCK	1
01000		
00FFF	4K-WORD BOOT BLOCK	0
00000		

BOTTOM BOOT

LRS1342-3

Figure 3. Bottom Boot for Flash Memory

[A <sub>0</sub> - A <sub>19</sub> ]		
FFFF		
F8000	4K-WORD BOOT BLOCK	0
F7FFF		
F0000	4K-WORD BOOT BLOCK	1
EFFFF		
E8000	4K-WORD PARAMETER BOOT BLOCK	0
E7FFF		
E0000	4K-WORD PARAMETER BOOT BLOCK	1
DFFFF		
D8000	4K-WORD PARAMETER BOOT BLOCK	2
D7FFF		
D0000	4K-WORD PARAMETER BOOT BLOCK	3
CFFFF		
C8000	4K-WORD PARAMETER BOOT BLOCK	4
C7FFF		
C0000	4K-WORD PARAMETER BOOT BLOCK	5
BFFFF		
B8000	32K-WORD MAIN BLOCK	0
B7FFF	32K-WORD MAIN BLOCK	1
B0000		
AFFFF	32K-WORD MAIN BLOCK	2
A8000		
A7FFF	32K-WORD MAIN BLOCK	3
A0000		
9FFFF	32K-WORD MAIN BLOCK	4
98000		
97FFF	32K-WORD MAIN BLOCK	5
90000		
8FFFF	32K-WORD MAIN BLOCK	6
88000		
87FFF	32K-WORD MAIN BLOCK	7
80000		
7FFFF	32K-WORD MAIN BLOCK	8
78000		
77FFF	32K-WORD MAIN BLOCK	9
70000		
6FFFF	32K-WORD MAIN BLOCK	10
68000		
67FFF	32K-WORD MAIN BLOCK	11
60000		
5FFFF	32K-WORD MAIN BLOCK	12
58000		
57FFF	32K-WORD MAIN BLOCK	13
50000		
4FFFF	32K-WORD MAIN BLOCK	14
48000		
47FFF	32K-WORD MAIN BLOCK	15
40000		
3FFFF	32K-WORD MAIN BLOCK	16
38000		
37FFF	32K-WORD MAIN BLOCK	17
30000		
2FFFF	32K-WORD MAIN BLOCK	18
28000		
27FFF	32K-WORD MAIN BLOCK	19
20000		
1FFFF	32K-WORD MAIN BLOCK	20
18000		
17FFF	32K-WORD MAIN BLOCK	21
10000		
0FFFF	32K-WORD MAIN BLOCK	22
08000		
07FFF	32K-WORD MAIN BLOCK	23
07000		
06FFF	32K-WORD MAIN BLOCK	24
06000		
05FFF	32K-WORD MAIN BLOCK	25
05000		
04FFF	32K-WORD MAIN BLOCK	26
04000		
03FFF	32K-WORD MAIN BLOCK	27
03000		
02FFF	32K-WORD MAIN BLOCK	28
02000		
01FFF	32K-WORD MAIN BLOCK	29
01000		
00FFF	32K-WORD MAIN BLOCK	30
00000		

LRS1342-13

Figure 4. Top Boot for Flash Memory

**ABSOLUTE MAXIMUM RATINGS**

PARAMETER	SYMBOL	RATINGS	UNIT	NOTES
Supply voltage	$V_{CC}$	-0.2 to +3.9	V	1, 2
Input voltage	$V_{IN}$	-0.2 to $V_{CC} + 0.3$	V	1, 3, 4
Operating temperature	$T_{OPR}$	-25 to +85	°C	
Storage temperature	$T_{STG}$	-55 to +125	°C	
F- $V_{PP}$ voltage	F- $V_{PP}$	-0.2 to +14.0	V	1, 4, 5
F- $\overline{RP}$ voltage	F- $\overline{RP}$	-0.5 to +14.0	V	1, 4, 5

**NOTES:**

1. The maximum applicable voltage on any pins with respect to GND.
2. Except F- $V_{PP}$ .
3. Except F- $\overline{RP}$ .
4. -2.0 V undershoot is allowed when the pulse width is less than 20 ns.
5. +14.0 V overshoot is allowed when the pulse width is less than 20 ns.

**RECOMMENDED DC OPERATING CONDITIONS**

$$T_A = -25^{\circ}\text{C to } +85^{\circ}\text{C}$$

PARAMETER	SYMBOL	MIN.	TYP.	MAX.	UNIT	NOTES
Supply voltage	$V_{CC}$	2.7	3.0	3.6	V	
Input voltage	$V_{IH}$	2.2		$V_{CC} + 0.2$	V	1
	$V_{IL}$	-0.2		0.6	V	2
	$V_{HH}$	11.4		12.6	V	3

**NOTES:**

1.  $V_{CC}$  is the lower one of S- $V_{CC}$  and F- $V_{CC}$ .
2. -2.0 V undershoot is allowed when the pulse width is less than 20 ns.
3. This voltage is applicable to F- $\overline{RP}$  pin only.

**PIN CAPACITANCE**

$$T_A = 25^{\circ}\text{C, } f = 1 \text{ MHz}$$

PARAMETER	SYMBOL	CONDITION	MIN.	TYP.	MAX.	UNIT
Input capacitance*	$C_{IN}$	$V_{IN} = 0 \text{ V}$			20	pF
I/O capacitance*	$C_{I/O}$	$V_{I/O} = 0 \text{ V}$			22	pF

**NOTE:** \*Sampled by not 100% tested.

## DC CHARACTERISTICS

 $T_A = -25^{\circ}\text{C to } +85^{\circ}\text{C}, V_{CC} = 2.7\text{ V to } 3.6\text{ V}$ 

PARAMETER		SYMBOL	CONDITION	MIN.	TYP. <sup>1</sup>	MAX.	UNIT	NOTES	
Input leakage current		$I_{LI}$	$V_{IN} = V_{CC}$ or GND	-1.5		+1.5	$\mu\text{A}$		
Output leakage current		$I_{LO}$	$V_{OUT} = V_{CC}$ or GND	-1.5		+1.5	$\mu\text{A}$		
F- $V_{CC}$	Standby Current	$I_{CCS}$	F- $\overline{CE} = F\text{-}\overline{RP} = F\text{-}V_{CC} \pm 0.2\text{ V}$ F- $\overline{WP} = F\text{-}V_{CC} \pm 0.2\text{ V}$ or F-GND $\pm 0.2\text{ V}$		25	50	$\mu\text{A}$	2	
			F- $\overline{CE} = F\text{-}\overline{RP} = V_{IH}$ , F- $\overline{WP} = V_{IH}$ or $V_{IL}$		0.2	2	$\text{mA}$		
	Deep Power-Down Current	$I_{CCD}$	F- $\overline{RP} = F\text{-}GND \pm 0.2\text{ V}$ , $I_{OUT} (F\text{-}RY/BY) = 0\text{ mA}$		5	10	$\mu\text{A}$		
	Read Current	$I_{CCR}$	CMOS input, F- $\overline{CE} = F\text{-}GND$ , $f = 5\text{ MHz}$ , $I_{OUT} = 0\text{ mA}$				25	$\text{mA}$	3, 4
			TTL input, F- $\overline{CE} = F\text{-}GND$ , $f = 5\text{ MHz}$ , $I_{OUT} = 0\text{ mA}$				30	$\text{mA}$	3, 4
	Word Write Current	$I_{CCW}$	F- $V_{PP} = 2.7\text{ V to } 3.6\text{ V}$				17	$\text{mA}$	
			F- $V_{PP} = 11.4\text{ V to } 12.6\text{ V}$				12	$\text{mA}$	
Block Erase Current	$I_{CCE}$	F- $V_{PP} = 2.7\text{ V to } 3.6\text{ V}$				17	$\text{mA}$		
		F- $V_{PP} = 11.4\text{ V to } 12.6\text{ V}$				12	$\text{mA}$		
Word Write Block Erase Suspend Current	$I_{CCWS}$ $I_{CCES}$	F- $\overline{CE} = V_{IH}$				6	$\text{mA}$		
F- $V_{PP}$	Standby or Read Current	$I_{PPS}$ $I_{PPR}$	F- $V_{PP} = F\text{-}V_{CC}$		$\pm 2$	$\pm 15$	$\mu\text{A}$		
			F- $V_{PP} > F\text{-}V_{CC}$		10	200	$\mu\text{A}$		
	Deep Power-Down Current	$I_{PPD}$	F- $\overline{RP} = F\text{-}GND \pm 0.2\text{ V}$		0.1	5	$\mu\text{A}$		
	Word Write Current	$I_{PPW}$	F- $V_{PP} = 2.7\text{ V to } 3.6\text{ V}$			12	40	$\text{mA}$	
			F- $V_{PP} = 11.4\text{ V to } 12.6\text{ V}$				30	$\text{mA}$	
	Block Erase Current	$I_{PPE}$	F- $V_{PP} = 2.7\text{ V to } 3.6\text{ V}$			8	25	$\text{mA}$	
F- $V_{PP} = 11.4\text{ V to } 12.6\text{ V}$						20	$\text{mA}$		
Word Write or Block Erase Suspend Current	$I_{PPWS}$ $I_{PPES}$	F- $V_{PP} = V_{PPH}$			10	200	$\mu\text{A}$		
S- $V_{CC}$	Standby Current	$I_{SB}$	S- $\overline{CE}_1$ , S- $\overline{CE}_2 \geq S\text{-}V_{CC} - 0.2\text{ V}$ or S- $\overline{CE}_2 \leq 0.2\text{ V}$			45	$\mu\text{A}$		
			S- $\overline{CE}_1 = V_{IH}$ or S- $\overline{CE}_2 = V_{IL}$			3	$\text{mA}$		
	Operation Current	$I_{CC1}$	S- $\overline{CE}_1 = V_{IL}$ , S- $\overline{CE}_2 = V_{IH}$ , $V_{IN} = V_{IL}$ or $V_{IH}$ , $t_{CYCLE} = \text{MIN.}$ , $I_{IO} = 0\text{ mA}$				45	$\text{mA}$	
			S- $\overline{CE}_1 = 0.2\text{ V}$ , S- $\overline{CE}_2 = S\text{-}V_{CC} - 0.2\text{ V}$ , $V_{IN} = S\text{-}V_{CC} - 0.2\text{ V}$ , or $0.2\text{ V}$ $t_{CYCLE} = 1\text{ }\mu\text{s}$ , $I_{IO} = 0\text{ mA}$				8	$\text{mA}$	
Input LOW Voltage	$V_{IL}$		-0.2		0.6	$\text{V}$			
Input HIGH Voltage	$V_{IH}$		2.2		$V_{CC} + 0.2$	$\text{V}$			
Output LOW Voltage	$V_{OL}$	$I_{OL} = 0.5\text{ mA}$			0.4	$\text{V}$	2		
Output HIGH Voltage (CMOS)	$V_{OH1}$	$I_{OH} = -0.5\text{ mA}$		2.2		$\text{V}$	2		
F- $V_{PP}$ Lockout during Normal Operations	$V_{PPLK}$				1.5	$\text{V}$	5		
F- $V_{PP}$ Word Write or Block Erase Operations	$V_{PPH1}$			2.7		3.6	$\text{V}$		
	$V_{PPH2}$			11.4		12.6	$\text{V}$		
F- $V_{CC}$ Lockout Voltage	$V_{LKO}$			1.5		$\text{V}$			
F- $\overline{RP}$ Unlock Voltage	$V_{HH}$	Unavailable F- $\overline{WP}$		11.4		12.6	$\text{V}$	6	

## NOTES:

- Reference values at  $V_{CC} = 3.0\text{ V}$  and  $T_A = +25^{\circ}\text{C}$ .
- Includes F- $\overline{RY}/\overline{BY}$ .
- Automatic Power Savings (APS) for Flash Memory reduces typical  $I_{CCR}$  to 3 mA at 2.7  $V_{CC}$  in static operation.
- CMOS inputs are either  $V_{CC} \pm 0.2\text{ V}$  or  $GND \pm 0.2\text{ V}$ . TTL inputs are either  $V_{IL}$  or  $V_{IH}$ .
- Block erases and word writes are inhibited when  $F\text{-}V_{PP} \leq V_{PPLK}$  and not guaranteed in the range between  $V_{PPLK}$  (MAX.) and  $V_{PPH}$  (MIN.), and above  $V_{PPH}$  (MAX.).
- F- $\overline{RP}$  connection to a  $V_{HH}$  supply is allowed for a maximum cumulative period of 80 hours.

## FLASH MEMORY AC CHARACTERISTICS

## AC Test Conditions

PARAMETER	CONDITION
Input pulse level	0 V to 2.7 V
Input rise and fall time	10 ns
Input and Output timing reference level	1.35 V
Output load	1TTL + C <sub>L</sub> (30 pF)

## Read Cycle

T<sub>A</sub> = -25°C to +85°C, V<sub>CC</sub> = 2.7 V to 3.6 V

PARAMETER	SYMBOL	MIN.	MAX.	UNIT
Read Cycle Time	t <sub>AVAV</sub>	100		ns
Address to Output Delay	t <sub>AVQV</sub>		100	ns
F- $\overline{\text{CE}}$ to Output Delay*	t <sub>ELQV</sub>		100	ns
F- $\overline{\text{RP}}$ HIGH to Output Delay	t <sub>PHQV</sub>		10	μs
F- $\overline{\text{OE}}$ to Output Delay*	t <sub>GLQV</sub>		45	ns
F- $\overline{\text{CE}}$ to Output in LOW-Z	t <sub>ELQX</sub>	0		ns
F- $\overline{\text{CE}}$ HIGH to Output in HIGH-Z	t <sub>EHQZ</sub>		45	ns
F- $\overline{\text{OE}}$ to Output in LOW Z	t <sub>GLQX</sub>	0		ns
F- $\overline{\text{OE}}$ HIGH to Output in HIGH-Z	t <sub>GHQZ</sub>		20	ns
Output Hold from Address, F- $\overline{\text{CE}}$ or F- $\overline{\text{OE}}$ change, whichever occurs first	t <sub>OH</sub>	0		ns

NOTE: \*F- $\overline{\text{OE}}$  may be delayed up to t<sub>ELQV</sub> - t<sub>GLQV</sub> after the falling edge of F- $\overline{\text{CE}}$  without impact on t<sub>ELQV</sub>.

**Write Cycle (F- $\overline{WE}$  Controlled)<sup>1</sup>**
 $T_A = -25^\circ\text{C to } +85^\circ\text{C}, V_{CC} = 2.7 \text{ V to } 3.6 \text{ V}$ 

PARAMETER	SYMBOL	MIN.	MAX.	UNIT
Write Cycle Time	$t_{AVAV}$	100		ns
F- $\overline{RP}$ HIGH Recovery to F- $\overline{WE}$ going to LOW	$t_{PHWL}$	10		$\mu\text{s}$
F- $\overline{CE}$ Setup to F- $\overline{WE}$ going LOW	$t_{ELWL}$	0		ns
F- $\overline{WE}$ Pulse Width	$t_{WLWH}$	50		ns
F- $\overline{RP}$ $V_{HH}$ Setup to F- $\overline{WE}$ going HIGH	$t_{PHHWH}$	100		ns
F- $\overline{WP}$ $V_{IH}$ Setup to F- $\overline{WE}$ going HIGH	$t_{SHWH}$	100		ns
F- $V_{PP}$ Setup to F- $\overline{WE}$ going HIGH	$t_{VPWH}$	100		ns
Address Setup to F- $\overline{WE}$ going HIGH <sup>2</sup>	$t_{AVWH}$	50		ns
Data Setup to F- $\overline{WE}$ going HIGH <sup>2</sup>	$t_{DVWH}$	50		ns
Data Hold from F- $\overline{WE}$ HIGH	$t_{WHDX}$	0		ns
Address Hold from F- $\overline{WE}$ HIGH	$t_{WHAX}$	0		ns
F- $\overline{CE}$ Hold from F- $\overline{WE}$ HIGH	$t_{WHEH}$	0		ns
F- $\overline{WE}$ Pulse Width HIGH	$t_{WHWL}$	30		ns
F- $\overline{WE}$ HIGH to F-RY/ $\overline{BY}$ going LOW	$t_{WHRL}$		100	ns
Write Recovery before Read	$t_{WHGL}$	0		ns
F- $V_{PP}$ Hold from Valid SRD, F-RY/ $\overline{BY}$ HIGH-Z	$t_{QVVL}$	0		ns
F- $\overline{RP}$ $V_{HH}$ Hold from Valid SRD, F-RY/ $\overline{BY}$ HIGH-Z	$t_{QVPH}$	0		ns
F- $\overline{WP}$ $V_{IH}$ Hold from Valid SRD, F-RY/ $\overline{BY}$ HIGH	$t_{QVSL}$	0		ns

**NOTES:**

1. Read timing characteristics during block erase and word write operations are the same as during read-only operations. Refer to AC Characteristics for Read Cycle.
2. Refer to the 'Flash Memory Command Definition' section for valid  $A_{IN}$  and  $D_{IN}$  for block erase or word write.

**Write Cycle (F- $\overline{\text{CE}}$  Controlled)<sup>1</sup>** $T_A = -25^\circ\text{C}$  to  $+85^\circ\text{C}$ ,  $V_{CC} = 2.7\text{ V}$  to  $3.6\text{ V}$ 

PARAMETER	SYMBOL	MIN.	MAX.	UNIT
Write Cycle Time	$t_{AVAV}$	100		ns
F- $\overline{\text{RP}}$ HIGH Recovery to F- $\overline{\text{CE}}$ going to LOW	$t_{PHEL}$	10		$\mu\text{s}$
F- $\overline{\text{WE}}$ Setup to F- $\overline{\text{CE}}$ going LOW	$t_{WLEL}$	0		ns
F- $\overline{\text{CE}}$ Pulse Width	$t_{ELEH}$	70		ns
F- $\overline{\text{RP}}$ $V_{HH}$ Setup to F- $\overline{\text{CE}}$ going HIGH	$t_{PHEH}$	100		ns
F- $\overline{\text{WP}}$ $V_{IH}$ Setup to F- $\overline{\text{CE}}$ going HIGH	$t_{SHEH}$	100		ns
F- $V_{PP}$ Setup to F- $\overline{\text{CE}}$ going HIGH	$t_{VPEH}$	100		ns
Address Setup to F- $\overline{\text{CE}}$ going HIGH <sup>2</sup>	$t_{AVEH}$	50		ns
Data Setup to F- $\overline{\text{CE}}$ going HIGH <sup>2</sup>	$t_{DVEH}$	50		ns
Data Hold from F- $\overline{\text{CE}}$ HIGH	$t_{EHDX}$	0		ns
Address Hold from F- $\overline{\text{CE}}$ HIGH	$t_{EHAX}$	0		ns
F- $\overline{\text{WE}}$ Hold from F- $\overline{\text{CE}}$ HIGH	$t_{EHWH}$	0		ns
F- $\overline{\text{CE}}$ Pulse Width HIGH	$t_{EHEL}$	25		ns
F- $\overline{\text{CE}}$ HIGH to F-RY/ $\overline{\text{BY}}$ going LOW	$t_{EHRL}$		100	ns
Write Recovery before Read	$t_{EHGL}$	0		ns
F- $V_{PP}$ Hold from Valid SRD, F-RY/ $\overline{\text{BY}}$ HIGH-Z	$t_{QVVL}$	0		ns
F- $\overline{\text{RP}}$ $V_{HH}$ Hold from Valid SRD, F-RY/ $\overline{\text{BY}}$ HIGH-Z	$t_{QVPH}$	0		ns
F- $\overline{\text{WP}}$ $V_{IH}$ Hold from Valid SRD, F-RY/ $\overline{\text{BY}}$ HIGH	$t_{QVSL}$	0		ns

**NOTES:**

- Read timing characteristics during block erase and word write operations are the same as during read-only operations. Refer to AC Characteristics for Read Cycle.
- Refer to the 'Flash Memory Command Definition' section for valid  $A_{IN}$  and  $D_{IN}$  for block erase or word write.

**Block Erase and Word Write Performance** $T_A = -25^\circ\text{C}$  to  $+85^\circ\text{C}$ ,  $V_{CC} = 2.7\text{ V}$  to  $3.6\text{ V}$ 

SYMBOL	PARAMETER	$V_{PP} = 2.7\text{ V to }3.6\text{ V}$			$V_{PP} = 11.4\text{ V to }12.6\text{ V}$			UNIT	NOTES
		MIN.	TYP. <sup>1</sup>	MAX.	MIN.	TYP. <sup>1</sup>	MAX.		
$t_{WHQV1}$	Word Write Time 32K-word Block		55			15		$\mu\text{s}$	2
$t_{EHQV1}$	Word Write Time 4K-word Block		60			30		$\mu\text{s}$	2
	Block Write Time 32K-word Block		1.8			0.6		s	2
	Block Write Time 4K-word Block		0.3			0.2		s	2
$t_{WHQV2}$	Block Erase Time 32K-word Block		1.2			0.7		s	2
$t_{EHQV2}$	Block Erase Time 4K-word Block		0.5			0.5		s	2
$t_{WHRZ1}$ $t_{EHRZ1}$	Word Write Suspend Latency Time to Read		7.5	8.6		6.5	7.5	$\mu\text{s}$	
$t_{WHRZ2}$ $t_{EHRZ2}$	Erase Suspend Latency Time to Read		19.3	23.6		11.8	15	$\mu\text{s}$	

**NOTES:**

- Reference values at  $T_A = +25^\circ\text{C}$  and  $V_{CC} = 3.0\text{ V}$ ,  $V_{PP} = 3.0\text{ V}$ .
- Excludes system-level overhead.

**FLASH MEMORY AC CHARACTERISTICS TIMING DIAGRAMS**

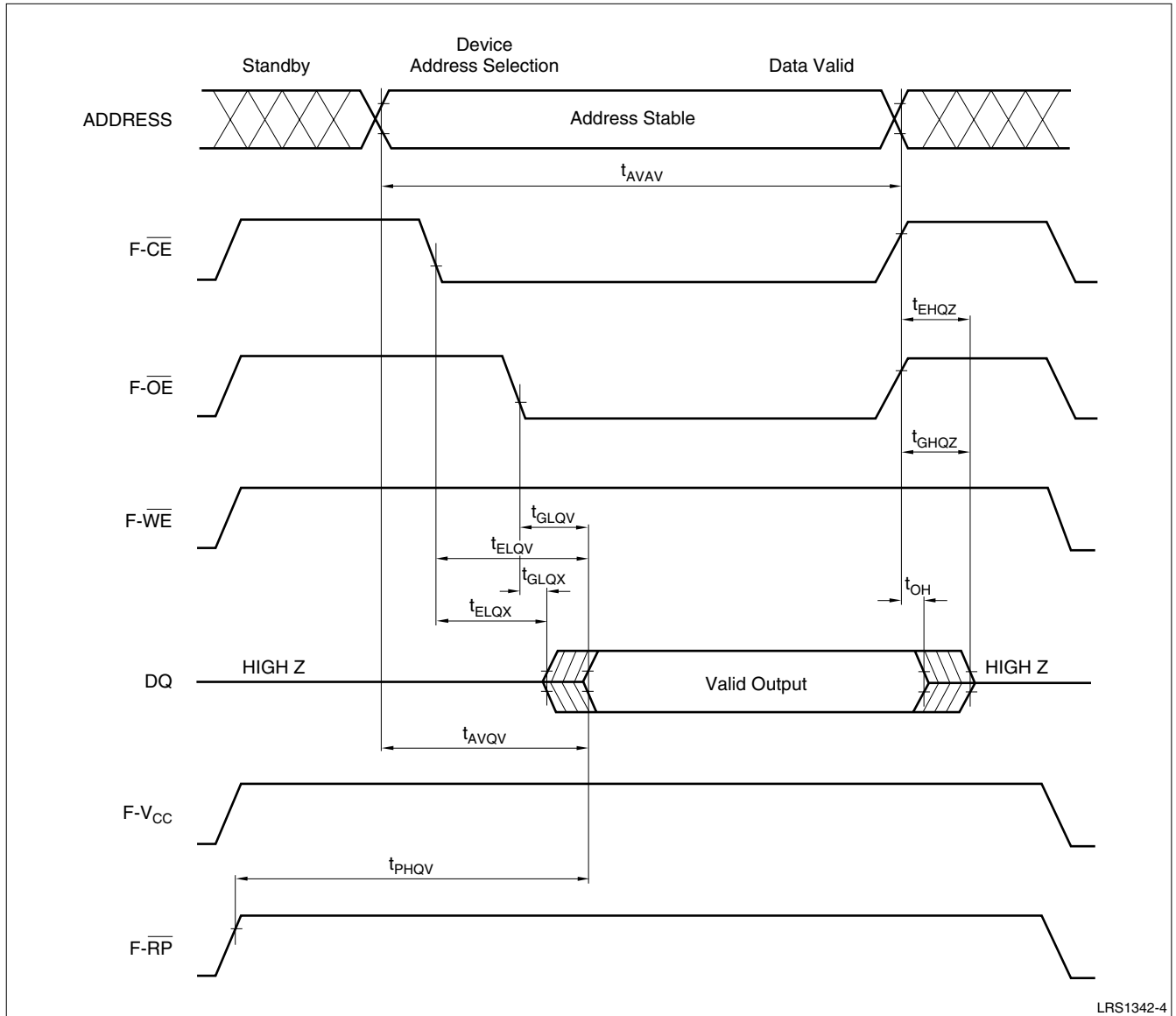

**Figure 5. Read Cycle Timing Diagram**

LRS1342-4

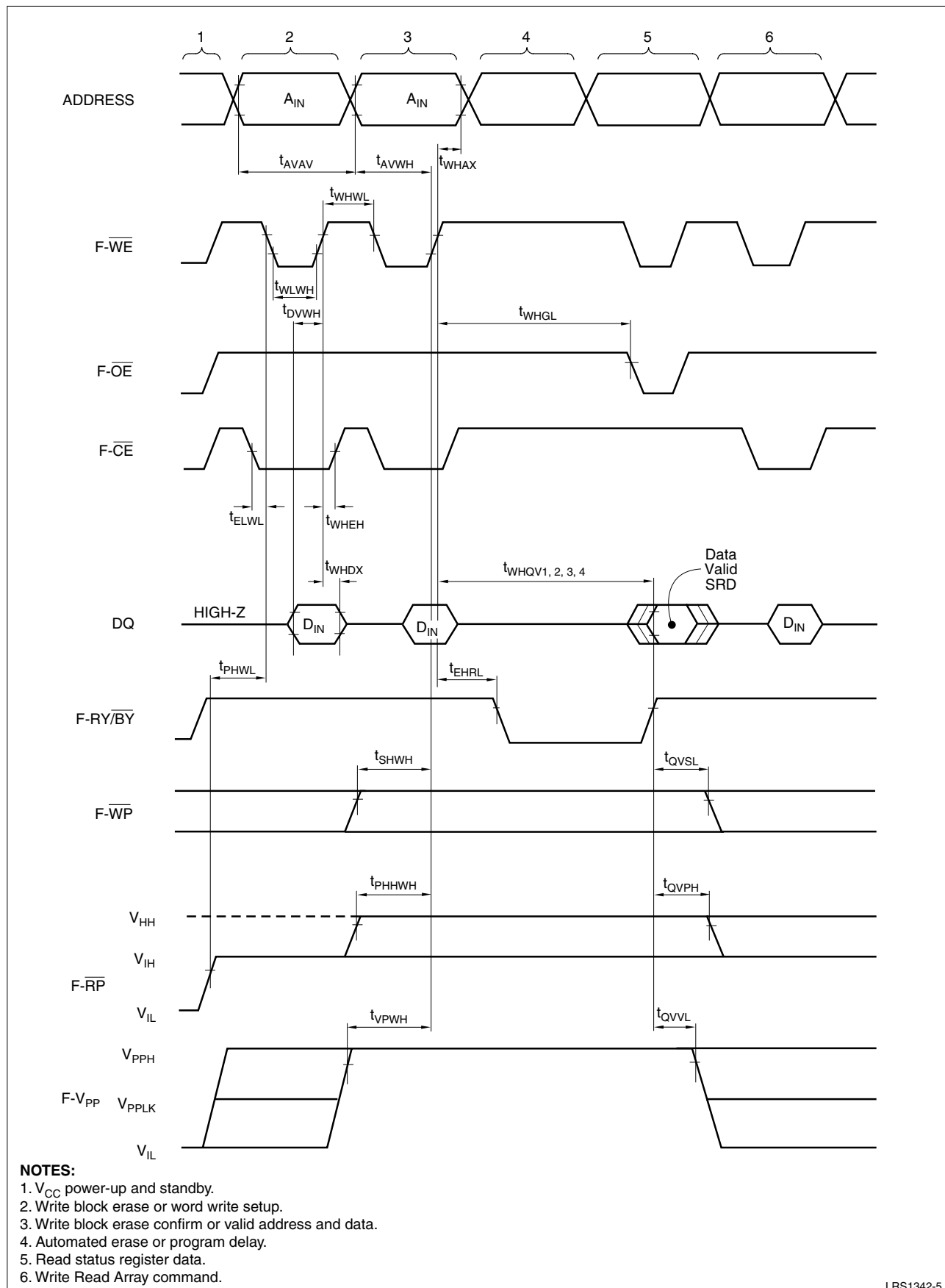
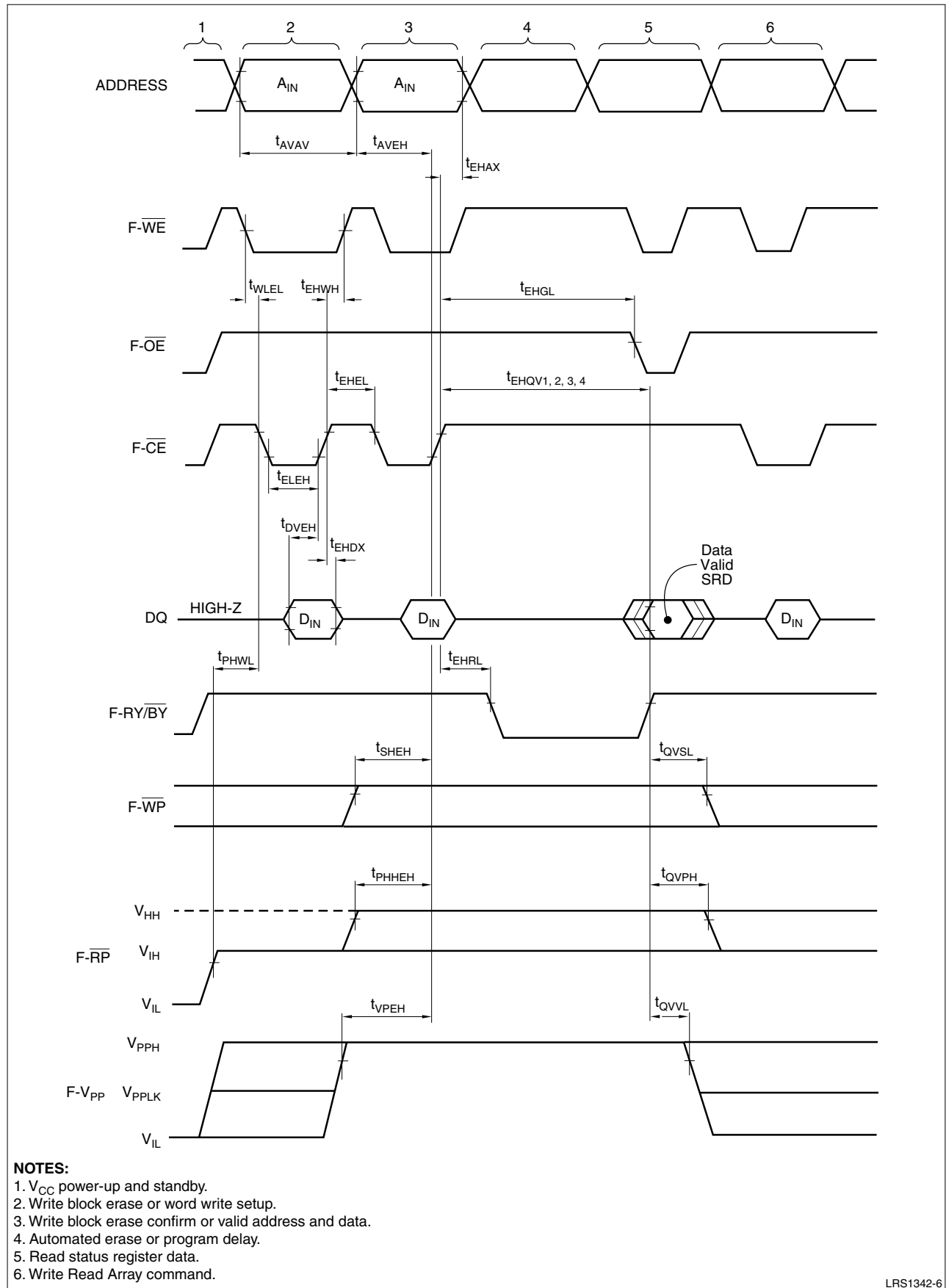

Figure 6. Write Cycle Timing Diagram (F-WE Controlled)



LRS1342-6

Figure 7. Write Cycle Timing Diagram ( $F\text{-}\overline{CE}$  Controlled)

## RESET OPERATIONS

$T_A = -25^\circ\text{C}$  to  $+85^\circ\text{C}$ ,  $V_{CC} = 2.7\text{ V}$  to  $3.6\text{ V}$

PARAMETER	SYMBOL	MIN.	MAX.	UNIT	NOTES
F- $\overline{\text{RP}}$ Pulse LOW Time (if F- $\overline{\text{RP}}$ is tied to $V_{CC}$ , this specification is not applicable).	$t_{\text{PLPH}}$	100		ns	
F- $\overline{\text{RP}}$ LOW to Reset during Block Erase or Word Write	$t_{\text{PLRZ}}$		23.6	$\mu\text{s}$	1, 2
F- $V_{CC}$ 2.7 V to F- $\overline{\text{RP}}$ HIGH	$t_{\text{VPH}}$	100		ns	3

### NOTES:

1. If F- $\overline{\text{RP}}$  is asserted while a block erase or word write operation is not executing, the reset will complete with 100 ns.
2. A reset time  $t_{\text{PHQV}}$  is required from the later of F-RY/ $\overline{\text{BY}}$  going HIGH-Z, or F- $\overline{\text{RP}}$  going HIGH until outputs are valid.
3. When the device power-up, holding F- $\overline{\text{RP}}$  LOW minimum 100 ns is required after  $V_{CC}$  has been in predefined range and also has been stable there.

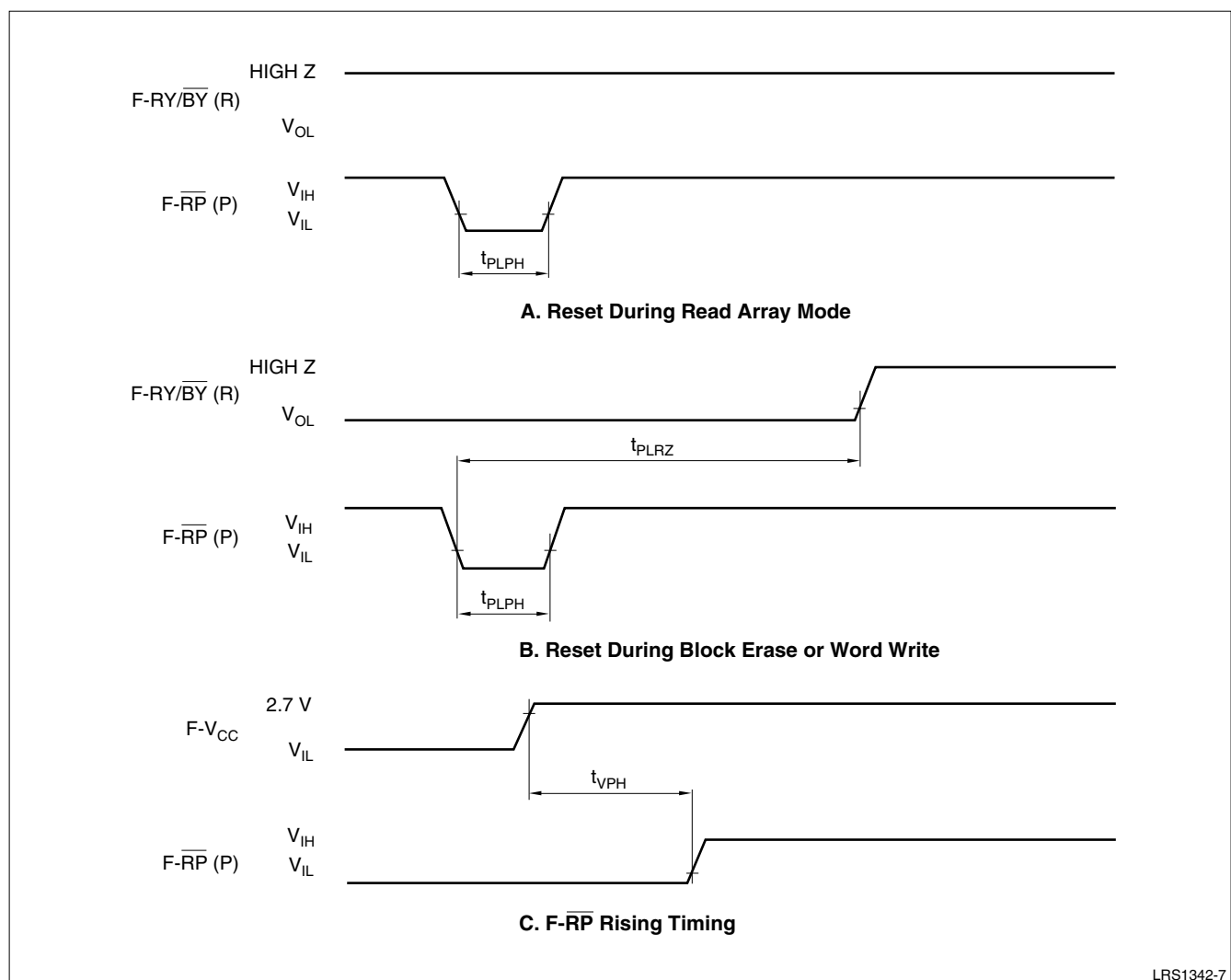

Figure 8. AC Waveform for Reset Operation

## SRAM AC ELECTRICAL CHARACTERISTICS

### AC Test Conditions

PARAMETER	CONDITION
Input Pulse Level	0.4 V to 2.7 V
Input Rise and Fall Time	5 ns
Input and Output Timing Reference Level	1.5 V
Output Load*	1TTL + C <sub>L</sub> (30 pF)

**NOTE:** \*Including scope and jig capacitance.

### Read Cycle

T<sub>A</sub> = -25°C to +85°C, V<sub>CC</sub> = 2.7 V to 3.6 V

PARAMETER	SYMBOL	MIN.	MAX.	UNIT
Read Cycle Time	t <sub>RC</sub>	85		ns
Address Access Time	t <sub>AA</sub>		85	ns
Chip Enable Access Time	S- $\overline{\text{CE}}_1$	t <sub>ACE1</sub>	85	ns
	S-CE <sub>2</sub>	t <sub>ACE2</sub>	85	ns
Byte Enable Access Time	t <sub>BE</sub>		85	ns
Output Enable to Output Valid	t <sub>OE</sub>		45	ns
Output hold from address change	t <sub>OH</sub>	10		ns
S- $\overline{\text{CE}}_1$ , S-CE <sub>2</sub> LOW to Output Active*	S- $\overline{\text{CE}}_1$	t <sub>LZ1</sub>	10	ns
	S-CE <sub>2</sub>	t <sub>LZ2</sub>	10	ns
S- $\overline{\text{OE}}$ LOW to Output Active*	t <sub>OLZ</sub>	10		ns
S- $\overline{\text{UB}}$ or S- $\overline{\text{LB}}$ LOW to Output in HIGH Impedance*	t <sub>BLZ</sub>	10		ns
S- $\overline{\text{CE}}_1$ , S-CE <sub>2</sub> HIGH to Output in HIGH Impedance*	S- $\overline{\text{CE}}_1$	t <sub>HZ1</sub>	0	25
	S-CE <sub>2</sub>	t <sub>HZ2</sub>	0	25
S- $\overline{\text{OE}}$ HIGH to Output in HIGH Impedance*	t <sub>OHZ</sub>	0	25	ns
S- $\overline{\text{UB}}$ or S- $\overline{\text{LB}}$ HIGH to Output in HIGH Impedance*	t <sub>BHZ</sub>	0	25	ns

**NOTE:** \*Active output to HIGH impedance and HIGH impedance to output active tests specified for a ±200 mV transition from steady state levels into the test load.

### Write Cycle

T<sub>A</sub> = -25°C to +85°C, V<sub>CC</sub> = 2.7 V to 3.6 V

PARAMETER	SYMBOL	MIN.	MAX.	UNIT
Write Cycle Time	t <sub>WC</sub>	85		ns
Chip Enable to End of Write	t <sub>CW</sub>	75		ns
Address Valid to End of Write	t <sub>AW</sub>	75		ns
Byte Enable to End of Write	t <sub>BW</sub>	75		ns
Address Setup Time	t <sub>AS</sub>	0		ns
Write Pulse Width	t <sub>WP</sub>	65		ns
Write Recovery Time	t <sub>WR</sub>	0		ns
Input Data Setup Time	t <sub>DW</sub>	35		ns
Input Data Hold Time	t <sub>DH</sub>	0		ns
S- $\overline{\text{WE}}$ HIGH to Output Active*	t <sub>OW</sub>	5		ns
S- $\overline{\text{WE}}$ LOW to Output in HIGH Impedance*	t <sub>WZ</sub>	0	25	ns

**NOTE:** \*Active output to HIGH impedance and HIGH impedance to output active tests specified for a ±200 mV transition from steady state levels into the test load.

## SRAM AC CHARACTERISTICS TIMING DIAGRAMS

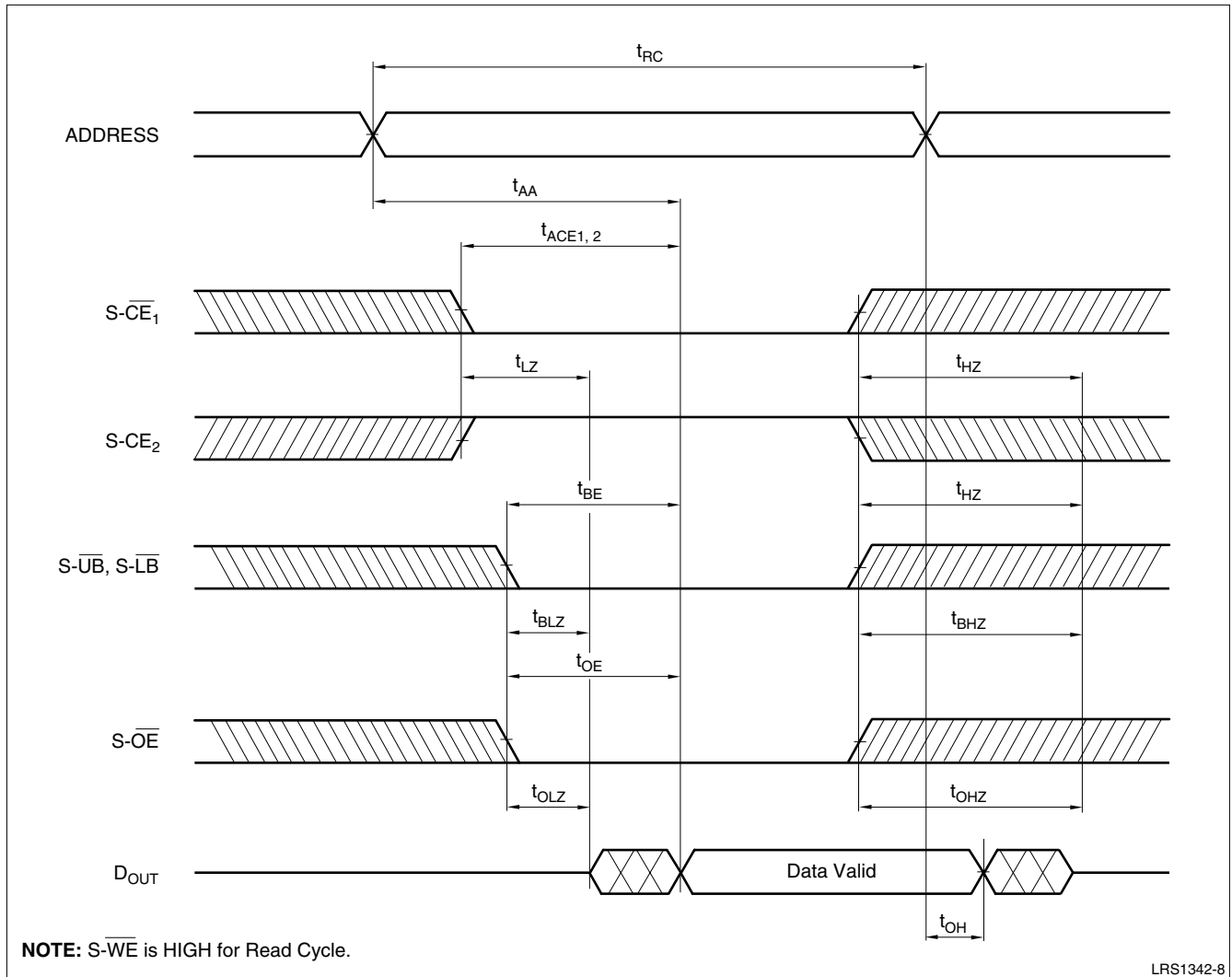
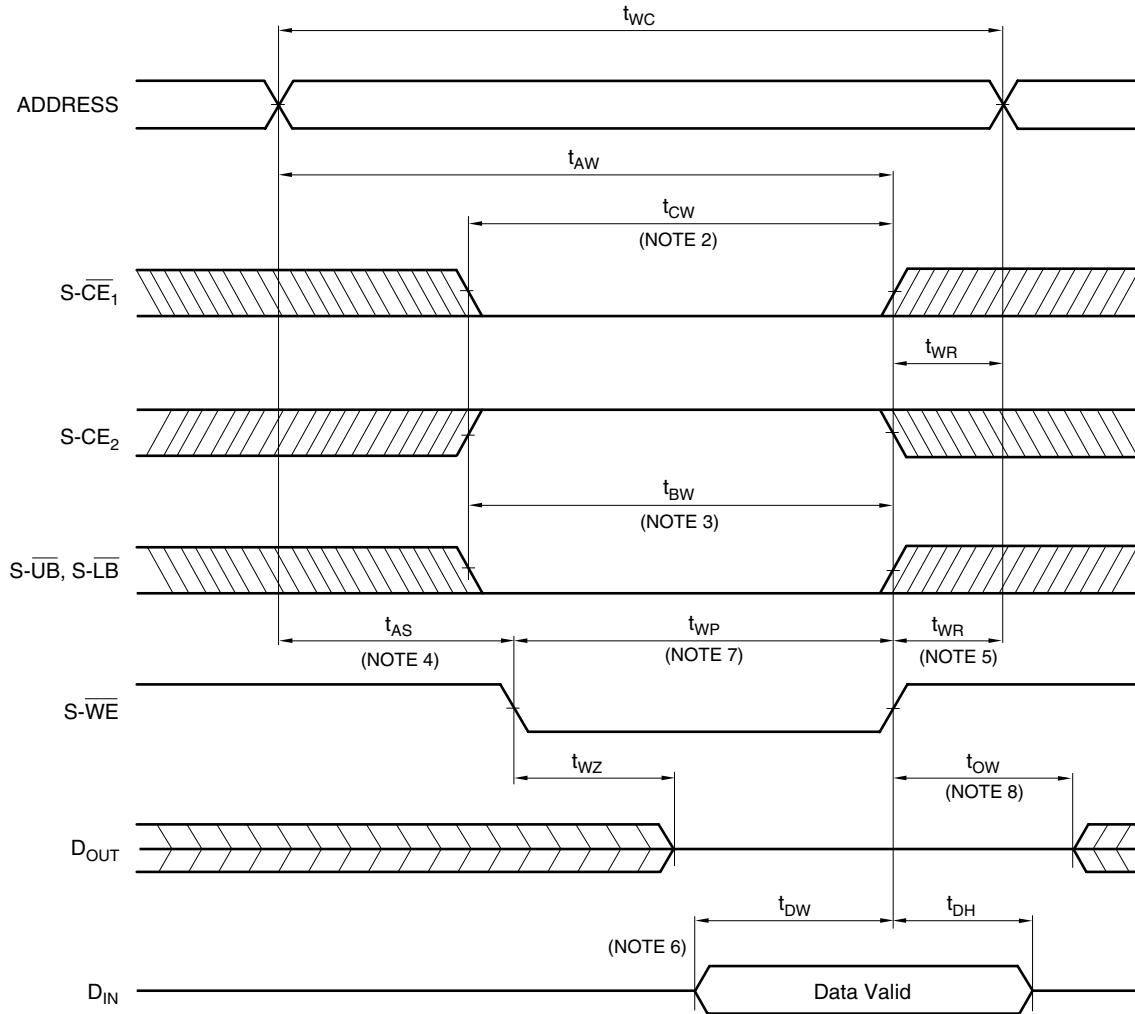

Figure 9. Read Cycle Timing Diagram

**NOTES:**

1. A write occurs during the overlap of a LOW  $S\text{-}\overline{CE}_1$ , a HIGH  $S\text{-}CE_2$  and a LOW  $S\text{-}\overline{WE}$ .  
A write begins at the latest transition among  $S\text{-}\overline{CE}_1$  going LOW,  $S\text{-}CE_2$  going HIGH and  $S\text{-}\overline{WE}$  going LOW. A write ends at the earliest transition among  $S\text{-}\overline{CE}_1$  going HIGH,  $S\text{-}CE_2$  going LOW and  $S\text{-}\overline{WE}$  going HIGH.  $t_{WP}$  is measured from the beginning of write to the end of write.
2.  $t_{CW}$  is measured from the later of  $S\text{-}\overline{CE}_1$  going LOW or  $S\text{-}CE_2$  going HIGH to the end of write.
3.  $t_{BW}$  is measured from the time of going LOW  $S\text{-}\overline{UB}$  or LOW  $S\text{-}\overline{LB}$  to the end of write.
4.  $t_{AS}$  is measured from the address valid to the beginning of write.
5.  $t_{WR}$  is measured from the end of write to the address change.
6. During this period, DQ pins are in the output state, therefore the input signals of opposite phase to the outputs must not be applied.
7. If  $S\text{-}\overline{CE}_1$  goes LOW or  $S\text{-}CE_2$  goes HIGH simultaneously with  $S\text{-}\overline{WE}$  going LOW or after  $S\text{-}\overline{WE}$  going LOW, the outputs remain in HIGH impedance state.
8. If  $S\text{-}\overline{CE}_1$  goes HIGH or  $S\text{-}CE_2$  goes LOW simultaneously with  $S\text{-}\overline{WE}$  going HIGH or  $S\text{-}\overline{WE}$  going HIGH, the outputs remain in HIGH impedance state.

LRS1342-9

**Figure 10. Write Cycle Timing Diagram ( $S\text{-}\overline{WE}$  Controlled)**

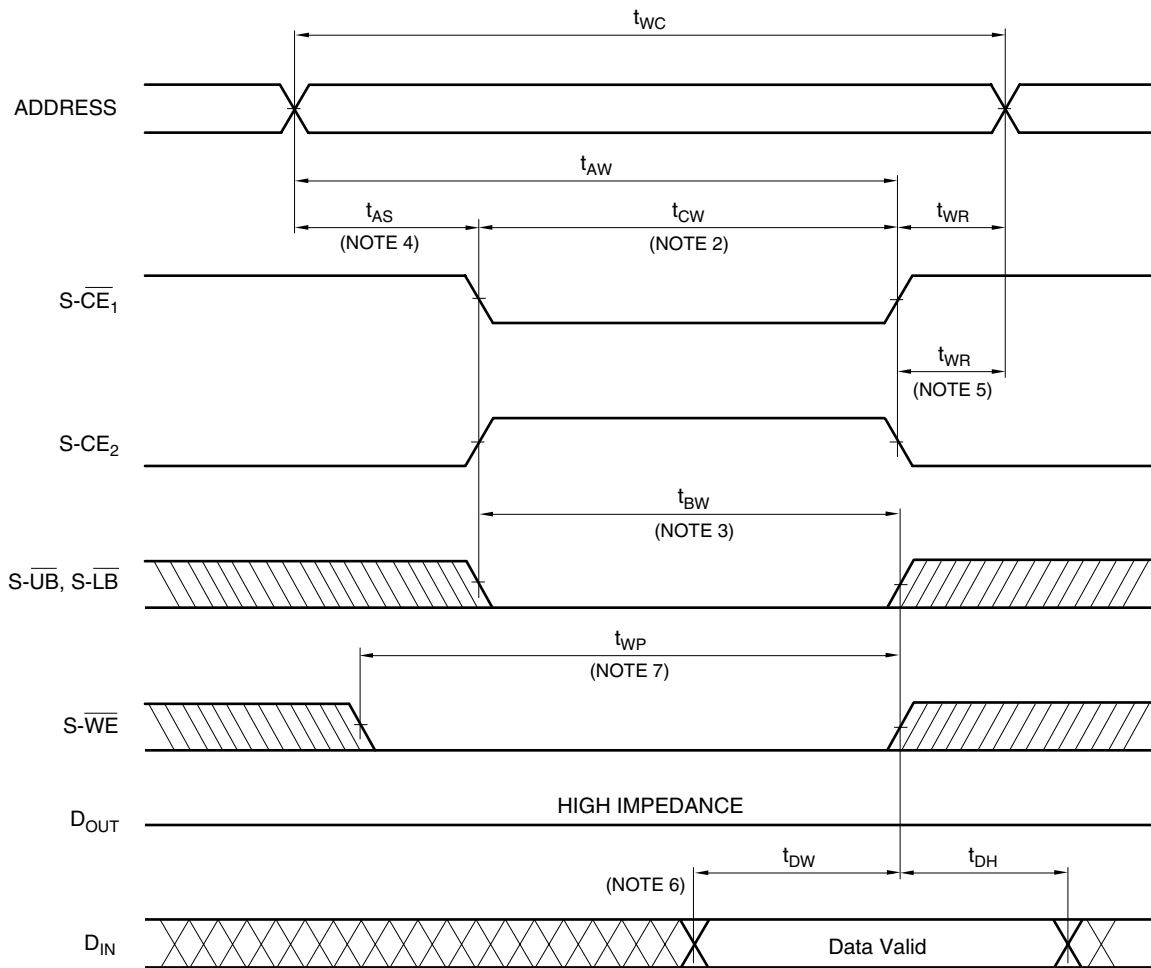
**NOTES:**

1. A write occurs during the overlap of a LOW S-CE<sub>1</sub>, a HIGH S-CE<sub>2</sub> and a LOW S-WE.  
A write begins at the latest transition among S-CE<sub>1</sub> going LOW, S-CE<sub>2</sub> going HIGH and S-WE going LOW. A write ends at the earliest transition among S-CE<sub>1</sub> going HIGH, S-CE<sub>2</sub> going LOW and S-WE going HIGH.  $t_{WP}$  is measured from the beginning of write to the end of write.
2.  $t_{CW}$  is measured from the later of S-CE<sub>1</sub> going LOW or S-CE<sub>2</sub> going HIGH to the end of write.
3.  $t_{BW}$  is measured from the time of going LOW S-UB or LOW S-LB to the end of write.
4.  $t_{AS}$  is measured from the address valid to the beginning of write.
5.  $t_{WR}$  is measured from the end of write to the address change.
6. During this period, DQ pins are in the output state, therefore the input signals of opposite phase to the outputs must not be applied.
7. If S-CE<sub>1</sub> goes LOW or S-CE<sub>2</sub> goes HIGH simultaneously with S-WE going LOW or after S-WE going LOW, the outputs remain in HIGH impedance state.

LRS1342-10

**Figure 11. Write Cycle Timing Diagram (S-CE Controlled)**

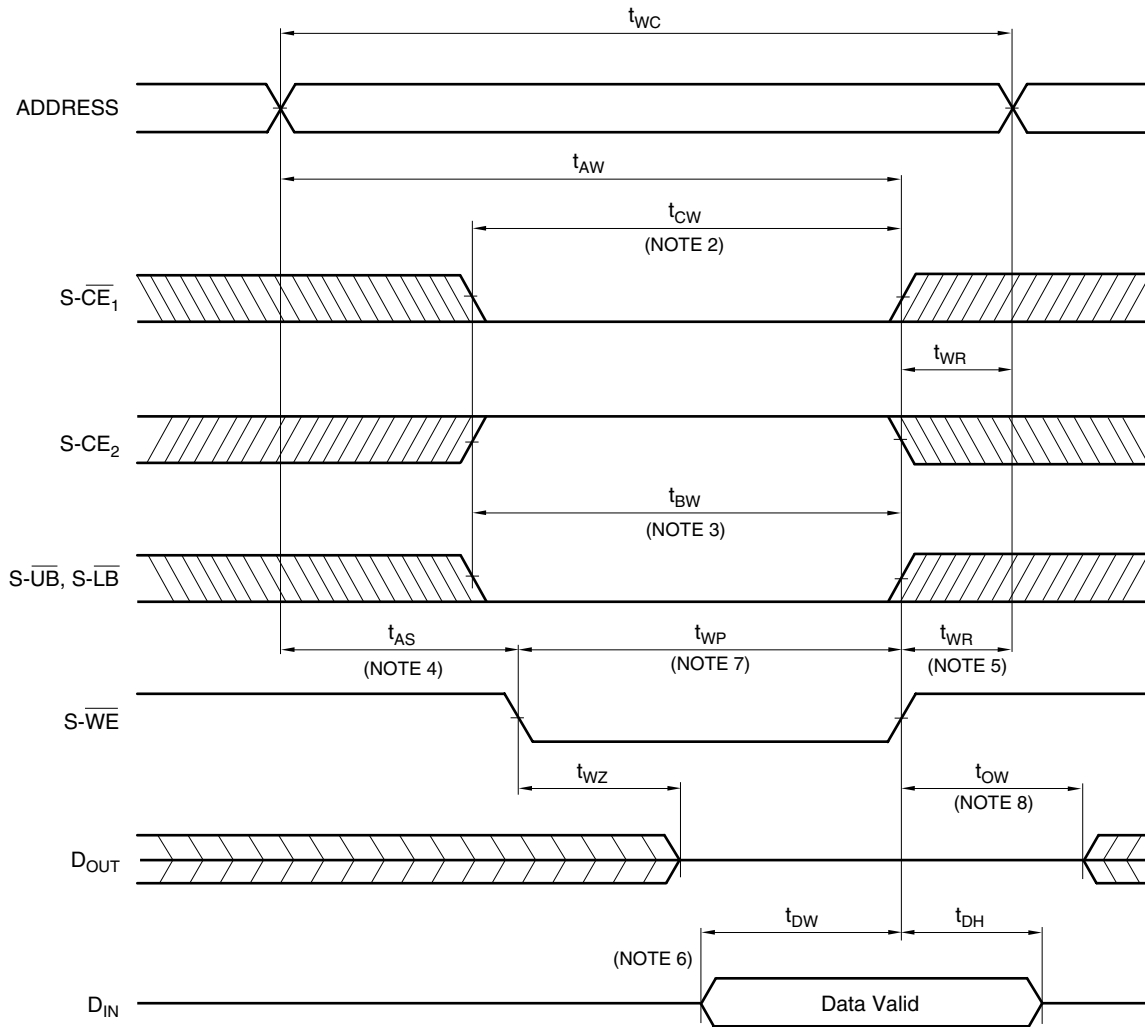
**NOTES:**

1. A write occurs during the overlap of a LOW S-CE<sub>1</sub>, a HIGH S-CE<sub>2</sub> and a LOW S-WE.  
A write begins at the latest transition among S-CE<sub>1</sub> going LOW, S-CE<sub>2</sub> going HIGH and S-WE going LOW. A write ends at the earliest transition among S-CE<sub>1</sub> going HIGH, S-CE<sub>2</sub> going LOW and S-WE going HIGH.  $t_{WP}$  is measured from the beginning of write to the end of write.
2.  $t_{CW}$  is measured from the later of S-CE<sub>1</sub> going LOW or S-CE<sub>2</sub> going HIGH to the end of write.
3.  $t_{BW}$  is measured from the time of going LOW S-UB or LOW S-LB to the end of write.
4.  $t_{AS}$  is measured from the address valid to the beginning of write.
5.  $t_{WR}$  is measured from the end of write to the address change.
6. During this period, DQ pins are in the output state, therefore the input signals of opposite phase to the outputs must not be applied.
7. If S-CE<sub>1</sub> goes LOW or S-CE<sub>2</sub> goes HIGH simultaneously with S-WE going LOW or after S-WE going LOW, the outputs remain in HIGH impedance state.
8. If S-CE<sub>1</sub> goes HIGH or S-CE<sub>2</sub> goes LOW simultaneously with S-WE going HIGH or S-WE going HIGH, the outputs remain in HIGH impedance state.

LRS1342-11

**Figure 12. Write Cycle Timing (S-UB, S-LB Controlled)**

## SRAM DATA RETENTION CHARACTERISTICS

 $T_A = -25^{\circ}\text{C}$  to  $+85^{\circ}\text{C}$ 

PARAMETER	SYMBOL	CONDITIONS	MIN.	TYP. <sup>1</sup>	MAX.	UNIT	NOTES
Data Retention Supply Voltage	$V_{\text{CCDR}}$	$S\text{-CE}_2 \leq 0.2\text{ V}$ or $S\text{-}\overline{\text{CE}}_1 \geq V_{\text{CCDR}} - 0.2\text{ V}$	2.0		3.6	V	2
Data Retention Supply Current	$I_{\text{CCDR}}$	$V_{\text{CCDR}} = 3\text{ V}$ , $S\text{-CE}_2 \leq 0.2\text{ V}$ or $S\text{-}\overline{\text{CE}}_1 \geq V_{\text{CCDR}} - 0.2\text{ V}$			35	$\mu\text{A}$	2
Chip Enable Setup Time	$t_{\text{CDR}}$		0			ns	
Chip Enable Hold Time	$t_{\text{R}}$		5			ms	

## NOTES:

- Reference value at  $T_A = 25^{\circ}\text{C}$ ,  $S\text{-}V_{\text{CC}} = 3.0\text{ V}$ .
- $S\text{-}\overline{\text{CE}}_1 \geq V_{\text{CC}} - 0.2\text{ V}$ ,  $S\text{-CE}_2 \geq V_{\text{CC}} - 0.2\text{ V}$  ( $S\text{-}\overline{\text{CE}}_1$  controlled) or  $S\text{-CE}_2 \leq 0.2\text{ V}$  ( $S\text{-CE}_2$  controlled).

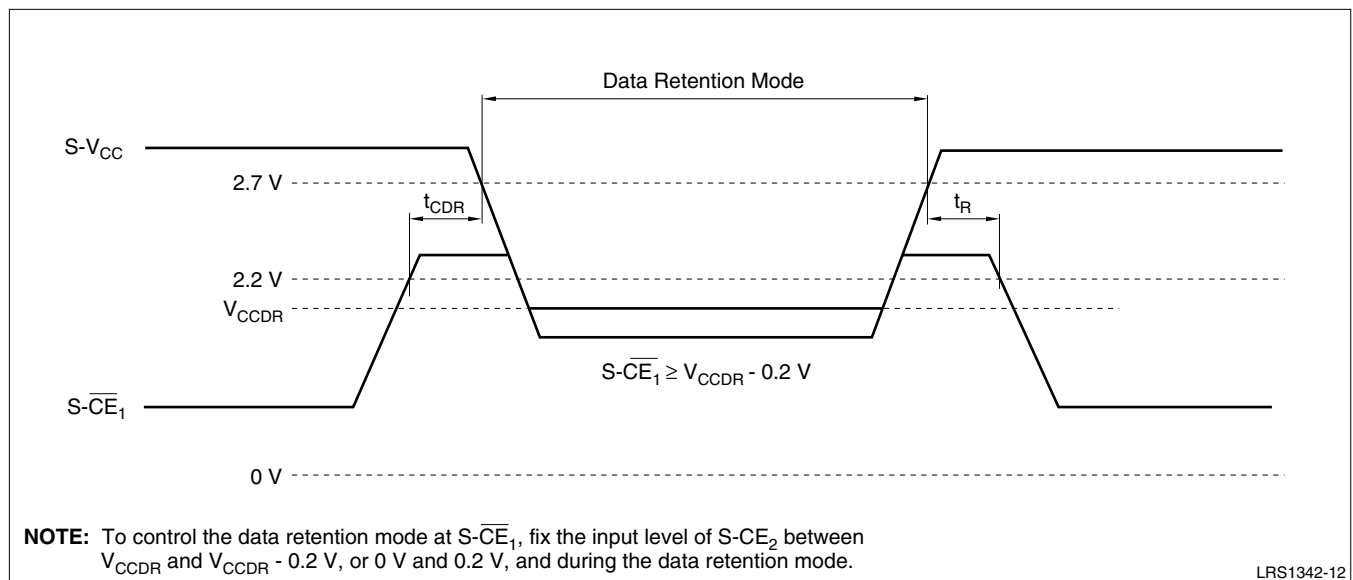

LRS1342-12

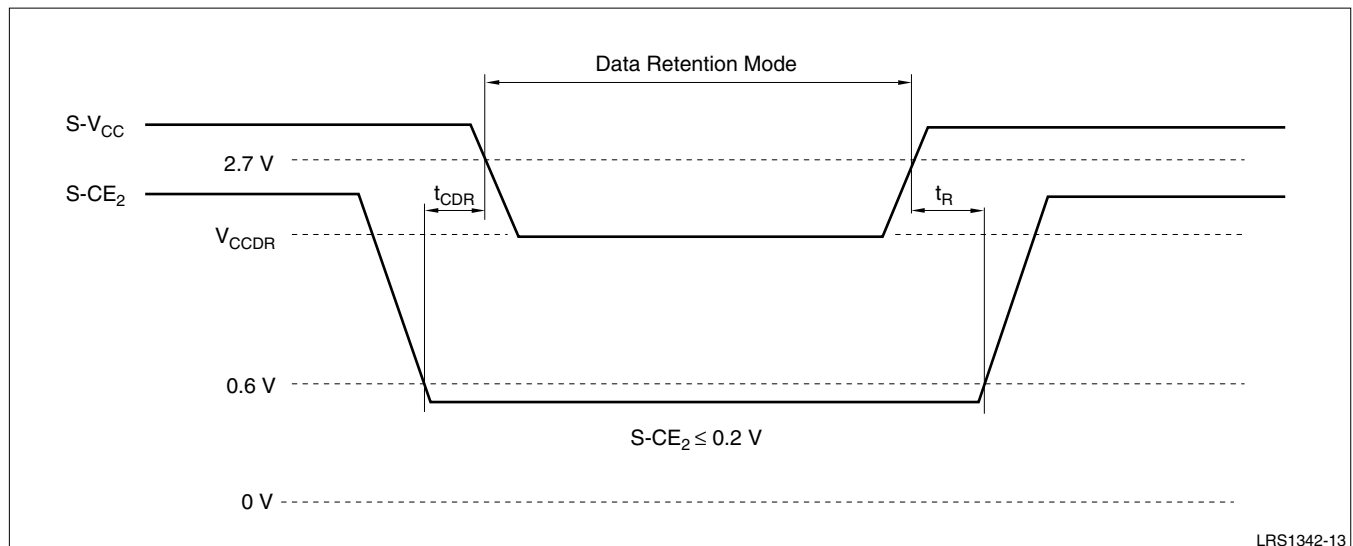
Figure 13. Data Retention Timing Diagram ( $S\text{-}\overline{\text{CE}}_1$  Controlled)

LRS1342-13

Figure 14. Data Retention Timing Diagram ( $S\text{-CE}_2$  Controlled)

## GENERAL DESIGN GUIDELINES

### Supply Power

Maximum difference (between  $F-V_{CC}$  and  $S-V_{CC}$ ) of the voltage is less than 0.3 V.

### Power Supply and Chip Enable of Flash Memory and SRAM

$S-\overline{CE}_1$  should not be LOW and  $S-CE_2$  should not be HIGH when  $F-\overline{CE}$  is LOW simultaneously.

If the two memories are active together, they may not operate normally because of interference noises or data collision on DQ bus.

Both  $F-V_{CC}$  and  $S-V_{CC}$  need to be applied by the recommended supply voltage at the same time except SRAM data retention mode.

### Power Up Sequence

When turning on Flash memory power supply, keep  $F-\overline{RP}$  LOW. After  $F-V_{CC}$  reaches over 2.7 V, keep  $F-\overline{RP}$  LOW for more than 100 ns.

### Device Decoupling

The power supply needs to be designed carefully because one of the SRAM and the Flash Memory is in standby mode when the other is active. A careful decoupling of power supplies is necessary between SRAM and Flash Memory. Note peak current caused by transition of control signals ( $F-\overline{CE}$ ,  $S-\overline{CE}_1$ ,  $S-CE_2$ ).

## FLASH MEMORY DATA PROTECTION

Noises having a level exceeding the limit specified in the specification may be generated under specific operating conditions on some systems.

Such noises, when induced onto  $F-\overline{WE}$  signal or power supply may be interpreted as false commands, causing undesired memory updating.

To protect the data stored in the flash memory against unwanted overwriting, systems operating with the flash memory should have the following write protect designs, as appropriate:

### Protecting Data in Specific Block

By setting a  $F-\overline{WP}$  to LOW, only the boot block can be protected against overwriting. Parameter and main blocks cannot be locked. System program, etc., can be locked by storing them in the boot block. When a high voltage is applied to  $F-\overline{RP}$ , overwrite operation is enabled for all blocks.

For further information on setting/resetting of block bit, and controlling of  $F-\overline{WP}$  and  $F-\overline{RP}$ , refer to the 'Command Definitions' section.

### Data Protection Through $F-V_{PP}$

When the level of  $F-V_{PP}$  is lower than  $F-V_{PPLK}$  (lock-out voltage), write operation on the flash memory is disabled. All blocks are locked and the data in the blocks are completely write protected.

For the lockout voltage refer to the 'DC Characteristics' section.

### Data Protection During Voltage Transition

#### DATA PROTECTION THROUGH $F-\overline{RP}$

When the  $F-\overline{RP}$  is kept LOW during power up and power down sequence, write operation on the flash memory is disabled, write protecting all blocks.

For details of  $F-\overline{RP}$  control refer to the 'Flash Memory AC Electrical Characteristics' section.

## DESIGN CONSIDERATIONS

### Power Supply Decoupling

To avoid a bad effect on the system by flash memory power switching characteristics, each device should have a 0.1  $\mu$ F ceramic capacitor connected between its  $V_{CC}$  and GND and between its  $V_{PP}$  and GND. LOW inductance capacitors should be placed as close as possible to package leads.

### $V_{PP}$ Trace on Printed Circuit Boards

Updating the memory contents of flash memories that reside in the target system requires that the printed circuit board designer pay attention to the  $V_{PP}$  Power Supply trace. Use similar trace widths and layout considerations given to the  $V_{CC}$  power bus.

### The Inhibition of Overwrite Operation

Please do not execute reprogramming '0' for the bit which has already been programmed '0'. Overwrite operation may generate unerasable bit. In case of reprogramming '0' to the data which has been programmed '1'.

- Program '0' for the bit in which you want to change data from '1' to '0'.
- Program '1' for the bit which has already been programmed '0'.

For example, changing data from '101110110111101' to '1010110110111100' requires '111011111111110' programming.

### Power Supply

Block erase, full chip erase, word write and lock-bit configuration with an invalid  $V_{PP}$  (see 'DC Characteristics') produce spurious results and should not be attempted. Device operations at invalid  $V_{CC}$  voltage produce spurious results and should be attempted.

OUTLINE DIMENSIONS

FBGA072-P-0811

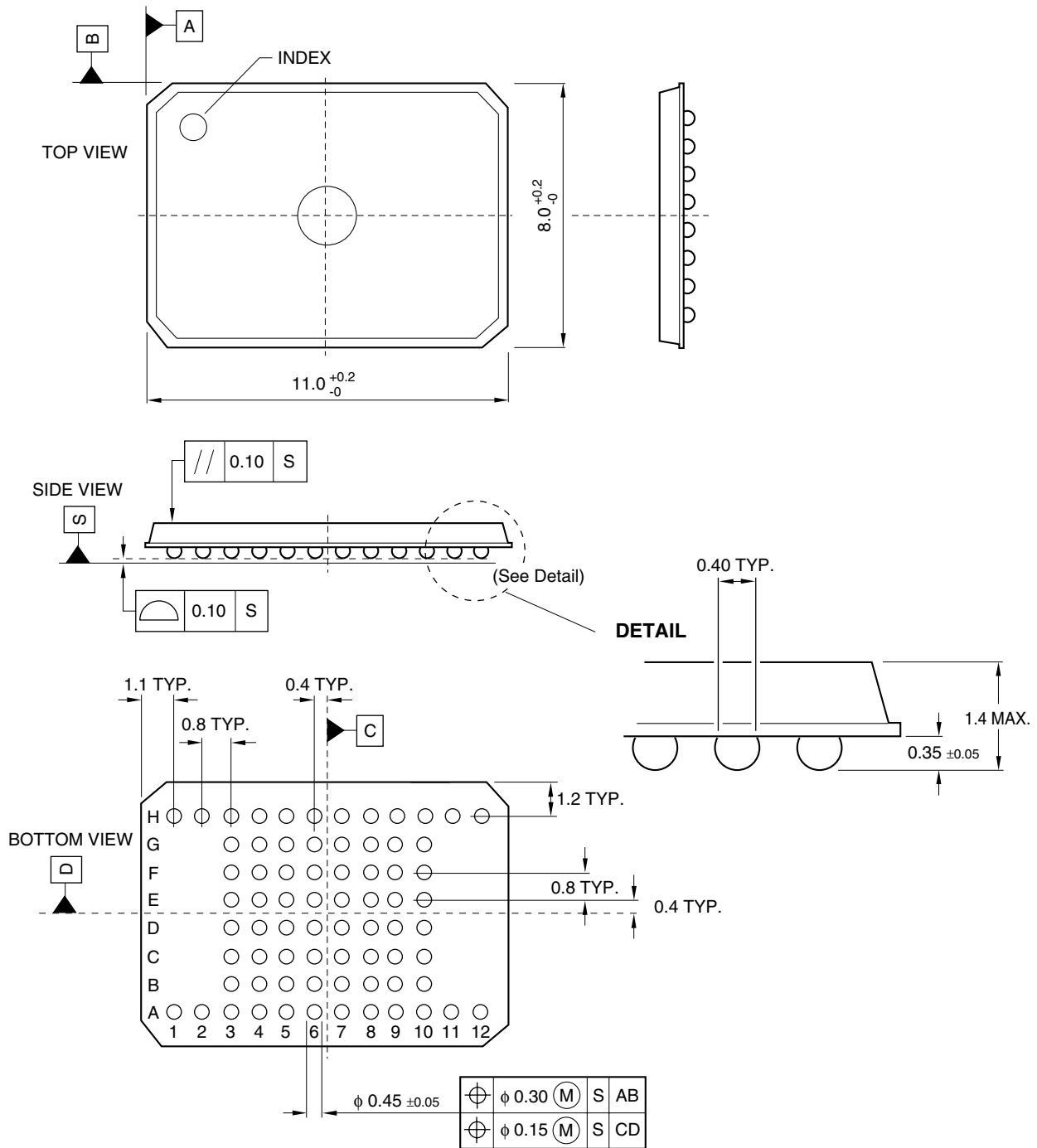

NOTE: Dimensions are in mm.

72FBGA

**LIFE SUPPORT POLICY**

SHARP components should not be used in medical devices with life support functions or in safety equipment (or similar applications where component failure would result in loss of life or physical harm) without the written approval of an officer of the SHARP Corporation.

**LIMITED WARRANTY**

SHARP warrants to its Customer that the Products will be free from defects in material and workmanship under normal use and service for a period of one year from the date of invoice. Customer's exclusive remedy for breach of this warranty is that SHARP will either (i) repair or replace, at its option, any Product which fails during the warranty period because of such defect (if Customer promptly reported the failure to SHARP in writing) or, (ii) if SHARP is unable to repair or replace, refund the purchase price of the Product upon its return to SHARP. This warranty does not apply to any Product which has been subjected to misuse, abnormal service or handling, or which has been altered or modified in design or construction, or which has been serviced or repaired by anyone other than Sharp. The warranties set forth herein are in lieu of, and exclusive of, all other warranties, express or implied. ALL EXPRESS AND IMPLIED WARRANTIES, INCLUDING THE WARRANTIES OF MERCHANTABILITY, FITNESS FOR USE AND FITNESS FOR A PARTICULAR PURPOSE, ARE SPECIFICALLY EXCLUDED. In no event will Sharp be liable, or in any way responsible, for any incidental or consequential economic or property damage.

The above warranty is also extended to Customers of Sharp authorized distributors with the following exception: reports of failures of Products during the warranty period and return of Products that were purchased from an authorized distributor must be made through the distributor. In case Sharp is unable to repair or replace such Products, refunds will be issued to the distributor in the amount of distributor cost.

SHARP reserves the right to make changes in specifications at any time and without notice. SHARP does not assume any responsibility for the use of any circuitry described; no circuit patent licenses are implied.

---

**SHARP**<sup>®</sup>**NORTH AMERICA**

---

SHARP Microelectronics  
of the Americas  
5700 NW Pacific Rim Blvd.  
Camas, WA 98607, U.S.A.  
Phone: (360) 834-2500  
Telex: 49608472 (SHARPCAM)  
Facsimile: (360) 834-8903  
<http://www.sharpsma.com>

**EUROPE**

---

SHARP Electronics (Europe) GmbH  
Microelectronics Division  
Sonninstraße 3  
20097 Hamburg, Germany  
Phone: (49) 40 2376-2286  
Facsimile: (49) 40 2376-2232  
<http://www.sharpmed.com>

**ASIA**

---

SHARP Corporation  
Integrated Circuits Group  
2613-1 Ichinomoto-Cho  
Tenri-City, Nara, 632, Japan  
Phone: +81-743-65-1321  
Facsimile: +81-743-65-1532  
<http://www.sharp.co.jp>