

Super-mini Signal Conditioners Mini-M Series

Screw terminal: Nickel-plated steel

INSTALLATION BASE (16 positions)

Functions & Features

- Receiving at the maximum of 16 modules of Mini-M series signal conditioners
- Screw terminal or connector output
- Power supplied through printed wiring on the base

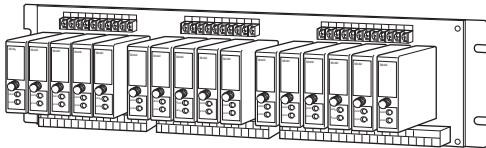

MODEL: M2BS-16[1][2]

ORDERING INFORMATION

- Code number: M2BS-16[1][2]
- Specify a code from below for each of [1] and [2].
(e.g. M2BS-16U2/D/UL)

[1] FUNCTION

- U0:** Screw terminal block
- U1:** Fujitsu FCN type I/O connector (UL not available)
- U2:** Omron I/O connector

[2] OPTIONS (multiple selections)

Mounting

- blank:** Surface
- /D:** DIN rail mounting adaptor (Not selectable for M2BS-16U0)

Standards & Approvals

- blank:** Without UL
- /UL:** UL approval

RELATED PRODUCTS

- Connector terminal block (model: CNT)
- Special cable with 40-pin connector (model: FCN)

GENERAL SPECIFICATIONS

- Capacity:** 16 positions
- Connection**
 - Power input:** M3 screw terminals (torque 0.8 N·m)
 - Input and output:** M3 screw terminals (torque 0.8 N·m)

INSTALLATION

- Power input:** Refer to signal conditioner data sheet. Choose the same power input specification for all units.
- Operating temperature:** -5 to +55°C (23 to 131°F)
- Operating humidity:** 30 to 90 %RH (non-condensing)
- Mounting:** Surface; optional DIN rail mounting available for M2BS-16U1, U2 (in horizontal direction only)
- Weight:** 1.8 kg (4.0 lb)

PERFORMANCE

- Insulation resistance:** $\geq 100 \text{ M}\Omega$ with 500 V DC (input to output to power to FG)
- Dielectric strength:** 2000 V AC @1 minute (input to output to power to FG)

STANDARDS & APPROVALS

EU conformity:

- EMC Directive
 - EMI EN 61000-6-4
 - EMS EN 61000-6-2
- Low Voltage Directive
 - EN 61010-1
 - Installation Category II
 - Pollution Degree 2
 - Input or output to power: Reinforced insulation (300 V)
 - Input to output: Basic insulation (300 V)
- RoHS Directive
 - EN 50581

Approval:

- UL/C-UL nonincendive Class I, Division 2, Groups A, B, C, and D (ANSI/ISA-12.12.01, CAN/CSA-C22.2 No.213)
- UL/C-UL general safety requirements (UL 3111-1, CAN/CSA-C22.2 No.1010-1)
- Voltage at the field I/O terminals (except power input terminals) limited within 30 V DC for UL.

CONNECTION DIAGRAM

■ MODEL: M2BS-16U0 (screw terminal block)

■ CONNECTION DIAGRAM

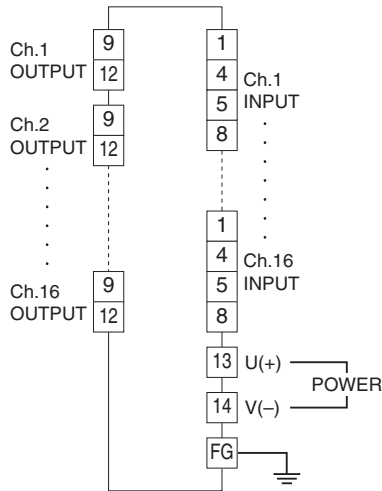

■ MODEL: M2BS-16U1 (Fujitsu FCN type I/O connector FCN364P040-AU)

• Connector Pin Assignment

CN1: output

PIN NO.	ASSIGNMENT	PIN NO.	ASSIGNMENT
A1	ch.1 +	B1	ch.1 -
A2	ch.2 +	B2	ch.2 -
A3	ch.3 +	B3	ch.3 -
A4	ch.4 +	B4	ch.4 -
A5	ch.5 +	B5	ch.5 -
A6	ch.6 +	B6	ch.6 -
A7	ch.7 +	B7	ch.7 -
A8	ch.8 +	B8	ch.8 -
A9	ch.9 +	B9	ch.9 -
A10	ch.10 +	B10	ch.10 -
A11	ch.11 +	B11	ch.11 -
A12	ch.12 +	B12	ch.12 -
A13	ch.13 +	B13	ch.13 -
A14	ch.14 +	B14	ch.14 -
A15	ch.15 +	B15	ch.15 -
A16	ch.16 +	B16	ch.16 -

A17 - A20, B17 - B20: Unused

■ CONNECTION DIAGRAM

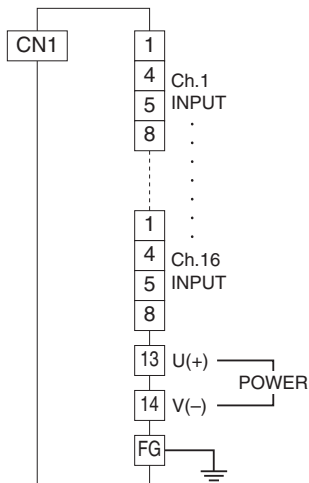

■ MODEL: M2BS-16U2 (Omron I/O connector XG4A-3431)

• Connector Pin Assignment

CN1: output

PIN NO.	ASSIGNMENT	PIN NO.	ASSIGNMENT
1	ch.1 +	2	ch.1 -
3	ch.2 +	4	ch.2 -
5	ch.3 +	6	ch.3 -
7	ch.4 +	8	ch.4 -
9	ch.5 +	10	ch.5 -
11	ch.6 +	12	ch.6 -
13	ch.7 +	14	ch.7 -
15	ch.8 +	16	ch.8 -
17	ch.9 +	18	ch.9 -
19	ch.10 +	20	ch.10 -
21	ch.11 +	22	ch.11 -
23	ch.12 +	24	ch.12 -
25	ch.13 +	26	ch.13 -
27	ch.14 +	28	ch.14 -
29	ch.15 +	30	ch.15 -
31	ch.16 +	32	ch.16 -
33, 34: Unused			

■ CONNECTION DIAGRAM

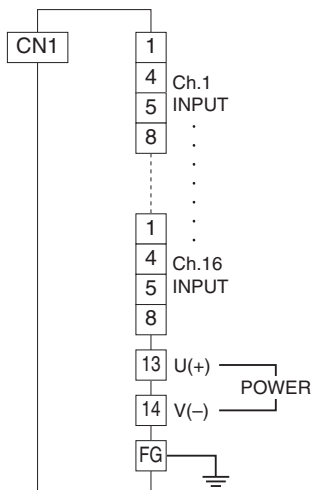

EXTERNAL DIMENSIONS & TERMINAL ASSIGNMENTS unit: mm (inch)

■ M2BS-16U0

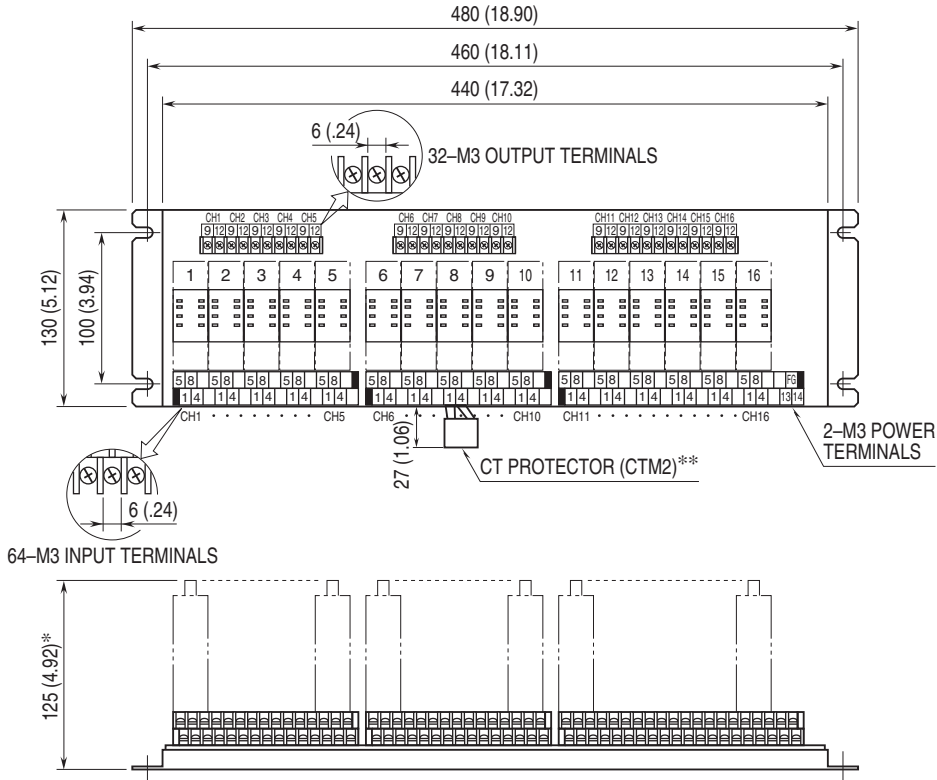

*165 (6.50) required for pneumatic tubing for M2PV.
 **Attached to M2CA and M2CE.

■ M2BS-16U1, U2

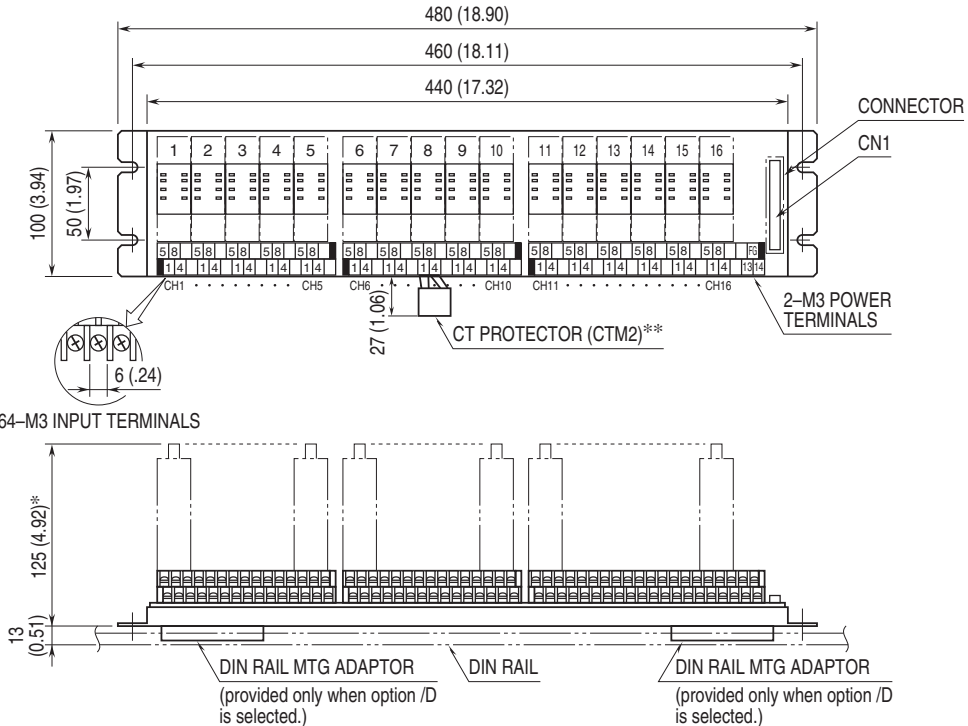

*165 (6.50) required for pneumatic tubing for M2PV.
 **Attached to M2CA and M2CE.

MOUNTING REQUIREMENTS unit: mm (inch)

■ M2BS-16U0

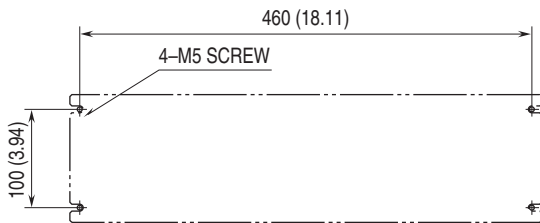

■ M2BS-16U1, U2

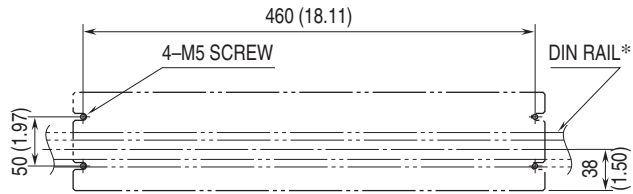

*Installed in horizontal direction only.



Specifications are subject to change without notice.