

Pb Free Plating Product

XS4202



20Amperes,200Volts Heatsink Common Cathode Ultra Fast Recovery Rectifiers

APPLICATION

- Freewheeling, Snubber, Clamp
- Inversion Welder
- PFC
- Plating Power Supply
- Ultrasonic Cleaner and Welder
- Converter & Chopper
- UPS

PRODUCT FEATURE

- Ultrafast Recovery Time
- Soft Recovery Characteristics
- Low Recovery Loss
- Low Forward Voltage
- High Surge Current Capability
- Low Leakage Current

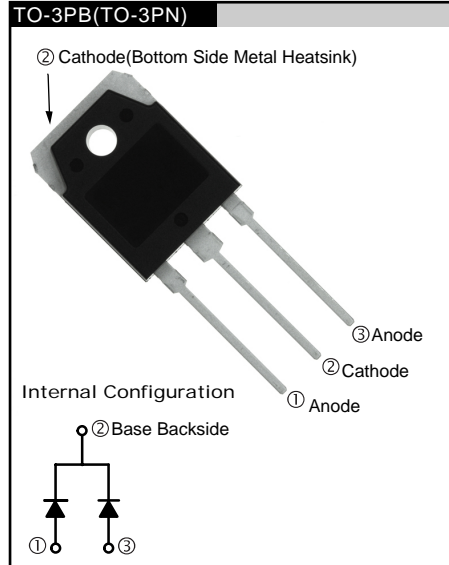

GENERAL DESCRIPTION

XS4202 using the latest FRED FAB process(planar passivation chip) with ultrafast and soft recovery characteristic.

Absolute Maximum Ratings				
Parameter	Symbol	Test Conditions	Values	Units
Repetitive peak reverse voltage	V_{RRM}		200	V
Continuous forward current(total device)	$I_{F(AV)}$	$T_c = 110^\circ\text{C}$	20	A
Single pulse forward current(total device)	I_{FSM}	$T_c = 25^\circ\text{C}$	200	
Maximum repetitive forward current	I_{FRM}	Square wave, 20kHz	50	
Operating junction	T_j		175	$^\circ\text{C}$
Storage temperatures	T_{stg}		-55 to +175	$^\circ\text{C}$

Electrical characteristics ($T_a=25^\circ\text{C}$ unless otherwise specified)						
Parameter	Symbol	Test Conditions	Min	Typ.	Max.	Units
Breakdown voltage Blocking voltage	V_{BR}, V_R	$I_R=100\mu\text{A}$	200			V
Forward voltage (Per Diode)	V_F	$I_F=10\text{A}$ $I_F=10\text{A}, T_j=125^\circ\text{C}$		0.88 0.78	1.20 1.15	
Reverse leakage current(Per Diode)	I_R	$V_R=V_{RRM}$ $T_j=150^\circ\text{C}, V_R=200\text{V}$			10 100	μA
Reverse recovery time(Per Diode)	t_{rr}	$I_F=0.5\text{A}, I_R=1\text{A}, I_{RR}=0.25\text{A}$ $I_F=1\text{A}, V_R=30\text{V}, di/dt=200\text{A}/\mu\text{s}$		30 20	40 30	ns

Thermal characteristics

Paramter	Symbol	Typ	Units
Junction-to-Case	$R_{\theta JC}$	0.80	$^\circ\text{C}/\text{W}$

Electrical performance (typical)

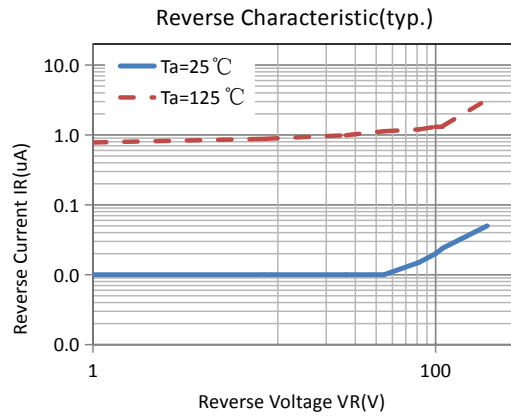
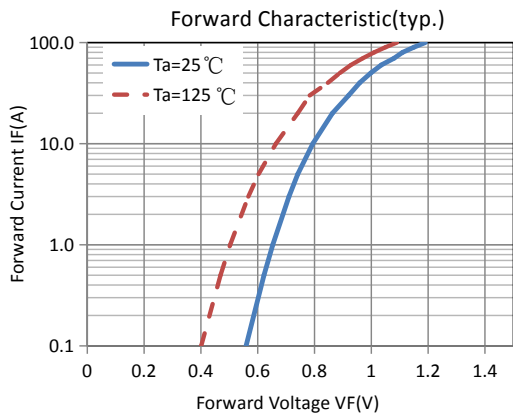

TO-3PB(TO-3PN) outline drawing

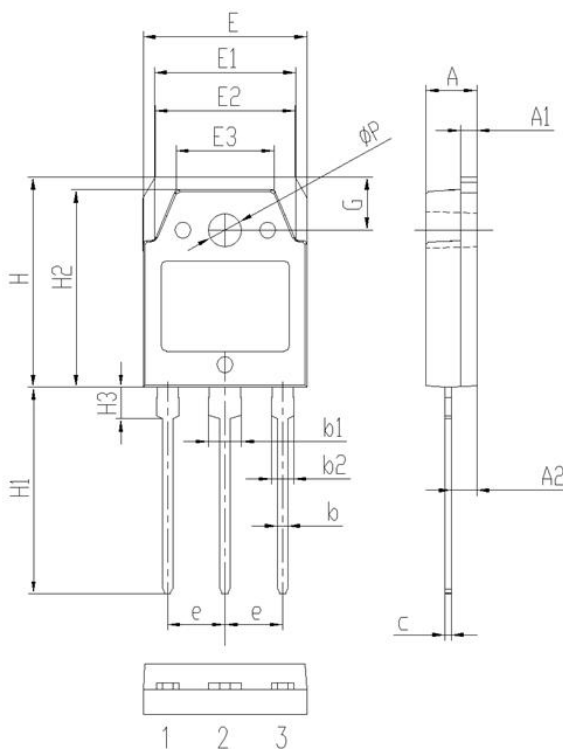

Symbol	Dimensions (millimeters)	
	Min.	Max.
A	4.60	5.00
A1	1.30	1.70
A2	2.20	2.60
b	0.80	1.20
b1	2.90	3.30
b2	1.90	2.30
c	0.40	0.80
e	5.25	5.65
E	15.3	15.7
E1	13.2	13.6
E2	13.1	13.5
E3	9.10	9.50
H	19.7	20.1
H1	19.1	20.1
H2	18.3	18.7
H3	2.80	3.20
G	4.80	5.20
ΦP	3.00	3.40