



DC COMPONENTS CO., LTD.

DISCRETE SEMICONDUCTORS

DC8050

TECHNICAL SPECIFICATIONS OF NPN EPITAXIAL PLANAR TRANSISTOR

Description

Designed for use in 2W output amplifier of portable radios in class B push-pull operation.

Pinning

- 1 = Emitter
- 2 = Base
- 3 = Collector

Absolute Maximum Ratings(T_A=25°C)

Characteristic	Symbol	Rating	Unit
Collector-Base Voltage	V _{CB0}	40	V
Collector-Emitter Voltage	V _{CEO}	25	V
Emitter-Base Voltage	V _{EBO}	6	V
Collector Current	I _C	1.5	A
Base Current	I _B	500	mA
Total Power Dissipation	P _D	1	W
Total Power Dissipation(T _C =25°C)	P _D	2	W
Junction Temperature	T _J	+150	°C
Storage Temperature	T _{STG}	-55 to +150	°C

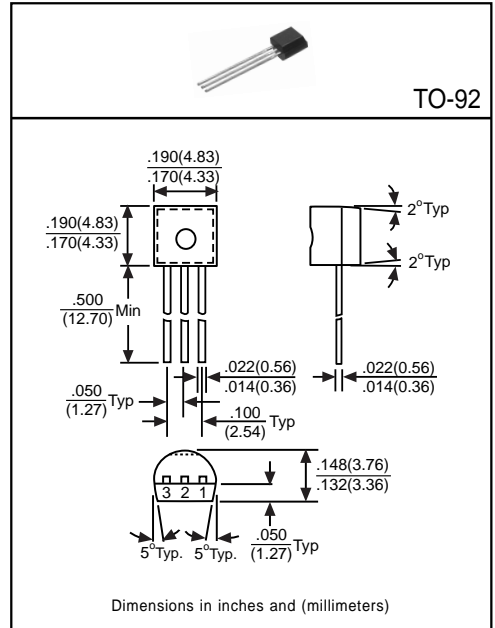

Electrical Characteristics

(Ratings at 25°C ambient temperature unless otherwise specified)

Characteristic	Symbol	Min	Typ	Max	Unit	Test Conditions
Collector-Base Breakdown Voltage	BV _{CB0}	40	-	-	V	I _C =100μA
Collector-Emitter Breakdown Voltage	BV _{CEO}	25	-	-	V	I _C =2mA
Emitter-Base Breakdown Voltage	BV _{EBO}	6	-	-	V	I _E =100μA
Collector Cutoff Current	I _{CBO}	-	-	0.1	μA	V _{CB} =35V
Emitter Cutoff Current	I _{EBO}	-	-	0.1	μA	V _{EB} =6V
Collector-Emitter Saturation Voltage ⁽¹⁾	V _{CE(sat)}	-	-	0.5	V	I _C =0.8A, I _B =80mA
Base-Emitter Saturation Voltage ⁽¹⁾	V _{BE(sat)}	-	-	1.2	V	I _C =0.8A, I _B =80mA
Base-Emitter On Voltage ⁽¹⁾	V _{BE(on)}	-	-	1	V	I _C =10mA, V _{CE} =1V
DC Current Gain ⁽¹⁾	hFE1	45	-	-	-	I _C =5mA, V _{CE} =1V
	hFE2	85	-	500	-	I _C =100mA, V _{CE} =1V
	hFE3	40	-	-	-	I _C =800mA, V _{CE} =1V
Transition Frequency	f _T	100	-	-	MHz	I _C =50mA, V _{CE} =10V

(1)Pulse Test: Pulse Width ≤ 380μs, Duty Cycle ≤ 2%

Classification of hFE2

Rank	B	C	D	E
Range	85~160	120~200	160~300	250~500