

Brushless DC (BLDC) Motor Control Board with Ethernet and CAN

Ordering Information

Order No.	Description
MDL-BLDC	Brushless DC Motor Control Board Only
RDK-BLDC	Stellaris® Brushless DC (BLDC) Motor Control Reference Design Kit (includes MDL-BLDC board)



Contents

General Description..... 1
 Overview 2
 General Features 2
 Communications Features 2
 Board Dimensions 2
Operational Specifications 3
 Maximum Ratings 4
 Wiring 4
Configurable Parameters 5
Additional Information 5

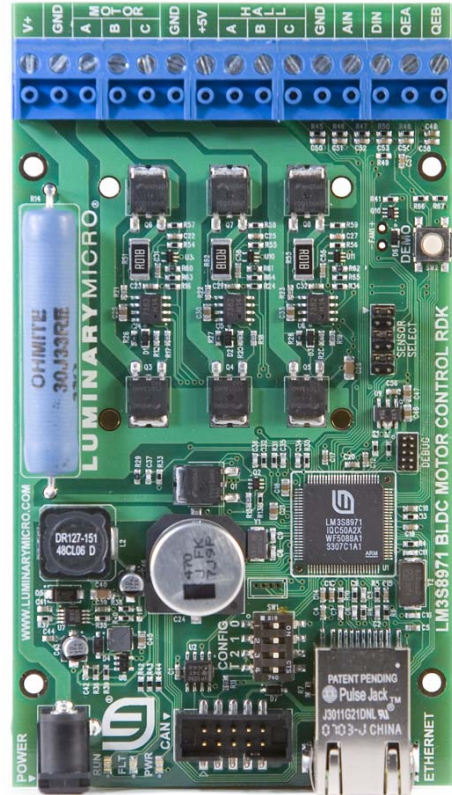

Figure 1. BLDC Motor Control Board

General Description

The brushless DC (BLDC) motor control board is a four-quadrant motor control board for three-phase BLDC motors rated at up to 36 V (see Figure 1). Key features include complete CAN and Ethernet communications interfaces, the powerful, 32-bit Stellaris® LM3S8971 microcontroller, and sophisticated software to optimally control a range of motors in diverse applications.

10/100 Ethernet connects the BLDC module to an array of networks—from dedicated industrial networks to the internet. The standard BLDC module includes the Stellaris motor control and configuration (MCC) protocol. This protocol can be replaced with any industry-standard protocol.

First-time users should purchase a complete BLDC reference design kit (RDK) which includes the control board, cables, configuration software (GUI), a documentation CD, and a sample motor. After evaluating the BLDC module, users may choose to either customize the design or use the BLDC board without modification. Refer to the *RDK-BLDC User's*

BOARD DATA SHEET

Guide (available for download from www.luminarymicro.com) for complete technical details on using and customizing the motor control board.

Overview

The MDL-BLDC control board provides the following features:

- Controls three-phase BLDC motors up to 36 V 500 W
- 10/100 Ethernet and CAN interfaces
- Four-quadrant operation
- Hall Effect, Quadrature, and Sensorless operation modes
- Extensive configuration options using Windows graphical user interface (GUI)
- Easy to customize—full source code and design files available

General Features

- On-board braking circuit
- Incremental quadrature encoder input
- Analog and digital control inputs
- Test mode push-button
- Status LEDs indicate Power, Run, and Fault conditions
- Optional power-managed fan for forced-air cooling
- Screw terminals for all power and signal wiring

Communications Features

- 10/100 Ethernet
 - Auto MDI/MDIX
 - Traffic and link indicator LEDs
 - MCC protocol supports multiple boards on the same network
- CAN bus
 - Support up to 1 Mbps
 - On-board selectable CAN terminator
- Serial port
 - Header provides TXD and RXD signals
 - CMOS signal levels
 - MCC communication protocol
 - 115.2 kbaud, 8 bit, no parity, 1 stop bit

Board Dimensions

Figure 2 on page 3 shows the board dimensions for the MDL-BLDC motor control board.



BOARD DATA SHEET



Figure 2. MDL-BLDC Board Dimensions

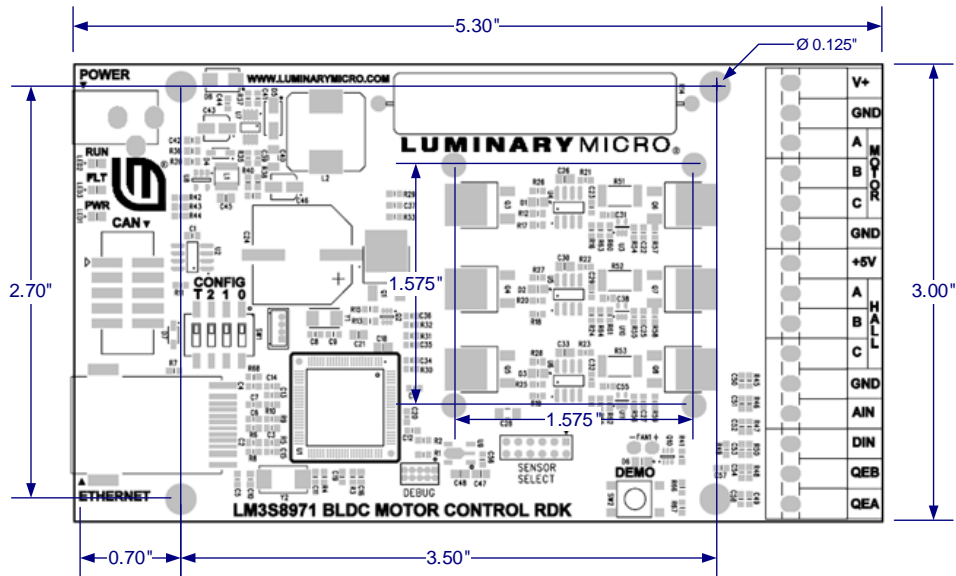

Operational Specifications

Table 1 shows the operating parameters for the MDL-BLDC motor control board.

Table 1. MDL-BLDC Operating Specifications

Parameter Name	Min	Nom	Max	Unit
Power Supply	12	–	36	V
Switching Frequency	8	16	20	kHz
Speed Range ^a	1	–	60,000	RPM
Continuous Output Current ^b	–	–	14	A
Continuous Output Current ^c	–	–	10	A
Operating Temperature Range	0	–	70	°C
Storage Temperature Range	-25	–	85	°C
Supply Current – Motor Stopped ^d	–	13	–	mA
Analog Input Range	0	–	5	V
Digital Input Low-Level Input Voltage	-0.3	–	1.3	V
Digital Input High-Level Input Voltage	2.0	–	5.0	V
Digital Input Pull-Up Resistor	–	6.8	–	kΩ
Hall Sensor Supply (at 5.0 V)	–	–	30	mA
Brake Resistor Continuous Power	–	–	10	W
Brake Resistor Peak Power (5 s)	–	–	50	W

a. Actual range depends on motor type

BOARD DATA SHEET

- b. At 25° C ambient
- c. At 40° C ambient
- d. With 24 V supply

Maximum Ratings

The maximum ratings are the limits to which the device can be subjected without causing permanent damage (see Table 2).

Table 2. MDL-BLDC Maximum Ratings

Parameter Name	Min	Nom	Max	Unit
DC Bus Voltage Range	10	–	60	V
Peak Output Current for 2 seconds	–	–	30	A
Continuous Output Power	–	–	500	W
Control Signal Input Range ^a	-0.3	–	5.5	V

- a. Applies to Hall Effect sensor, analog, and digital inputs

Wiring

The MDL-BLDC motor control board is controlled by one of the three communication interfaces, or by a simple analog control voltage. Figure 3 shows power, motor, and peripheral connections to the main terminal block. Connections to the Hall sensors, analog speed control potentiometer, and quadrature/incremental encoder are all optional.



Figure 3. Terminal Wiring Diagram

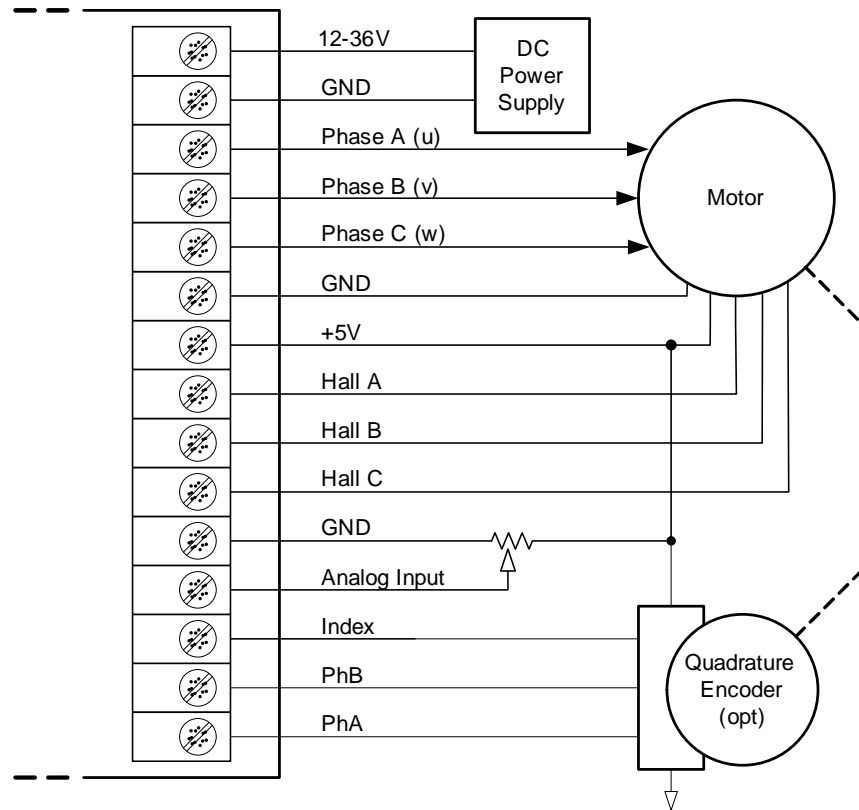

Configurable Parameters

The follow list shows just a few of the parameters that can be configured by the GUI or directly using the MCC protocol:

- Motor poles
- Speed range
- Motor current and voltage
- Acceleration and deceleration rate
- Control method: Hall effect sensors or back-EMF
- Trapezoidal (BLDC) or sinusoidal (PMAC, BLDC) control
- Control-loop coefficients

Additional Information

The following documents are available for download at www.luminarymicro.com:

- *RDK-BLDC User's Manual*, Publication Number RDK-BLDC-UM
- *RDK-BLDC Quickstart*

Important Notice

Texas Instruments Incorporated and its subsidiaries (TI) reserve the right to make corrections, modifications, enhancements, improvements, and other changes to its products and services at any time and to discontinue any product or service without notice. Customers should obtain the latest relevant information before placing orders and should verify that such information is current and complete. All products are sold subject to TI's terms and conditions of sale supplied at the time of order acknowledgment.

TI warrants performance of its hardware products to the specifications applicable at the time of sale in accordance with TI's standard warranty. Testing and other quality control techniques are used to the extent TI deems necessary to support this warranty. Except where mandated by government requirements, testing of all parameters of each product is not necessarily performed.

TI assumes no liability for applications assistance or customer product design. Customers are responsible for their products and applications using TI components. To minimize the risks associated with customer products and applications, customers should provide adequate design and operating safeguards.

TI does not warrant or represent that any license, either express or implied, is granted under any TI patent right, copyright, mask work right, or other TI intellectual property right relating to any combination, machine, or process in which TI products or services are used. Information published by TI regarding third-party products or services does not constitute a license from TI to use such products or services or a warranty or endorsement thereof. Use of such information may require a license from a third party under the patents or other intellectual property of the third party, or a license from TI under the patents or other intellectual property of TI.

Reproduction of TI information in TI data books or data sheets is permissible only if reproduction is without alteration and is accompanied by all associated warranties, conditions, limitations, and notices. Reproduction of this information with alteration is an unfair and deceptive business practice. TI is not responsible or liable for such altered documentation. Information of third parties may be subject to additional restrictions.

Resale of TI products or services with statements different from or beyond the parameters stated by TI for that product or service voids all express and any implied warranties for the associated TI product or service and is an unfair and deceptive business practice. TI is not responsible or liable for any such statements.

TI products are not authorized for use in safety-critical applications (such as life support) where a failure of the TI product would reasonably be expected to cause severe personal injury or death, unless officers of the parties have executed an agreement specifically governing such use. Buyers represent that they have all necessary expertise in the safety and regulatory ramifications of their applications, and acknowledge and agree that they are solely responsible for all legal, regulatory and safety-related requirements concerning their products and any use of TI products in such safety-critical applications, notwithstanding any applications-related information or support that may be provided by TI. Further, Buyers must fully indemnify TI and its representatives against any damages arising out of the use of TI products in such safety-critical applications.

TI products are neither designed nor intended for use in military/aerospace applications or environments unless the TI products are specifically designated by TI as military-grade or "enhanced plastic." Only products designated by TI as military-grade meet military specifications. Buyers acknowledge and agree that any such use of TI products which TI has not designated as military-grade is solely at the Buyer's risk, and that they are solely responsible for compliance with all legal and regulatory requirements in connection with such use.

TI products are neither designed nor intended for use in automotive applications or environments unless the specific TI products are designated by TI as compliant with ISO/TS 16949 requirements. Buyers acknowledge and agree that, if they use any non-designated products in automotive applications, TI will not be responsible for any failure to meet such requirements.

Following are URLs where you can obtain information on other Texas Instruments products and application solutions:

Products

Amplifiers	amplifier.ti.com
Data Converters	dataconverter.ti.com
DLP® Products	www.dlp.com
DSP	dsp.ti.com
Clocks and Timers	www.ti.com/clocks
Interface	interface.ti.com
Logic	logic.ti.com
Power Mgmt	power.ti.com
Microcontrollers	microcontroller.ti.com
RFID	www.ti-rfid.com
RF/IF and ZigBee® Solutions	www.ti.com/lprf

Applications

Audio	www.ti.com/audio
Automotive	www.ti.com/automotive
Broadband	www.ti.com/broadband
Digital Control	www.ti.com/digitalcontrol
Medical	www.ti.com/medical
Military	www.ti.com/military
Optical Networking	www.ti.com/opticalnetwork
Security	www.ti.com/security
Telephony	www.ti.com/telephony
Video & Imaging	www.ti.com/video
Wireless	www.ti.com/wireless

Mailing Address: Texas Instruments, Post Office Box 655303, Dallas, Texas 75265

Copyright © 2009, Texas Instruments Incorporated

Copyright © 2007–2009 Texas Instruments, Inc. All rights reserved.
 Stellaris and StellarisWare are registered trademarks of Texas Instruments. ARM and Thumb are registered trademarks, and Cortex is a trademark of ARM Limited. Other names and brands may be claimed as the property of others.

