

Features

- High-performance, Low-power AVR[®] 8-bit Microcontroller
- Advanced RISC Architecture
 - 90 Powerful Instructions – Most Single Clock Cycle Execution
 - 32 x 8 General Purpose Working Registers
 - Fully Static Operation
- Non-volatile Program and Data Memories
 - 1K Byte In-System Programmable Flash Program Memory
Endurance: 1,000 Write/Erase Cycles
 - 64 Bytes EEPROM
Endurance: 100,000 Write/Erase Cycles
 - Programming Lock for Flash Program Data Security
- Peripheral Features
 - Interrupt and Wake-up on Pin Change
 - Two 8-bit Timer/Counters with Separate Prescalers
 - One 150 kHz, 8-bit High-speed PWM Output
 - 4-channel 10-bit ADC
One Differential Voltage Input with Optional Gain of 20x
 - On-chip Analog Comparator
 - Programmable Watchdog Timer with On-chip Oscillator
- Special Microcontroller Features
 - In-System Programmable via SPI Port
 - Enhanced Power-on Reset Circuit
 - Programmable Brown-out Detection Circuit
 - Internal, Calibrated 1.6 MHz Tunable Oscillator
 - Internal 25.6 MHz Clock Generator for Timer/Counter
 - External and Internal Interrupt Sources
 - Low-power Idle and Power-down Modes
- Power Consumption at 1.6 MHz, 3V, 25°C
 - Active: 3.0 mA
 - Idle Mode: 1.0 mA
 - Power-down: < 1 µA
- I/O and Packages
 - 8-lead PDIP and 8-lead SOIC: 6 Programmable I/O Lines
- Operating Voltages
 - 2.7V - 5.5V
- Internal 1.6 MHz System Clock

Pin Configuration

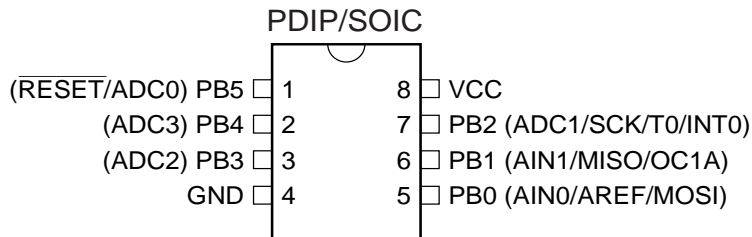

8-bit AVR[®] Microcontroller with 1K Byte Flash

ATtiny15L

Not recommended for new design

Rev. 1187H-AVR-09/07





Description

The ATtiny15L is a low-power CMOS 8-bit microcontroller based on the AVR RISC architecture. By executing powerful instructions in a single clock cycle, the ATtiny15L achieves throughputs approaching 1 MIPS per MHz allowing the system designer to optimize power consumption versus processing speed.

The AVR core combines a rich instruction set with 32 general purpose working registers. All the 32 registers are directly connected to the Arithmetic Logic Unit (ALU), allowing two independent registers to be accessed in one single instruction executed in one clock cycle. The resulting architecture is more code efficient while achieving throughputs up to ten times faster than conventional CISC microcontrollers.

The ATtiny15L provides 1K byte of Flash, 64 bytes EEPROM, six general purpose I/O lines, 32 general purpose working registers, two 8-bit Timer/Counters, one with high-speed PWM output, internal Oscillators, internal and external interrupts, programmable Watchdog Timer, 4-channel 10-bit Analog-to-Digital Converter with one differential voltage input with optional 20x gain, and three software-selectable Power-saving modes. The Idle mode stops the CPU while allowing the ADC, anAlog Comparator, Timer/Counters and interrupt system to continue functioning. The ADC Noise Reduction mode facilitates high-accuracy ADC measurements by stopping the CPU while allowing the ADC to continue functioning. The Power-down mode saves the register contents but freezes the Oscillators, disabling all other chip functions until the next interrupt or Hardware Reset. The wake-up or interrupt on pin change features enable the ATtiny15L to be highly responsive to external events, still featuring the lowest power consumption while in the Power-saving modes.

The device is manufactured using Atmel's high-density, Non-volatile memory technology. By combining a RISC 8-bit CPU with Flash on a monolithic chip, the ATtiny15L is a powerful microcontroller that provides a highly flexible and cost-efficient solution to many embedded control applications. The peripheral features make the ATtiny15L particularly suited for battery chargers, lighting ballasts and all kinds of intelligent sensor applications.

The ATtiny15L AVR is supported with a full suite of program and system development tools including macro assemblers, program debugger/simulators, In-circuit emulators and evaluation kits.

Block Diagram

Figure 1. The ATtiny15L Block Diagram

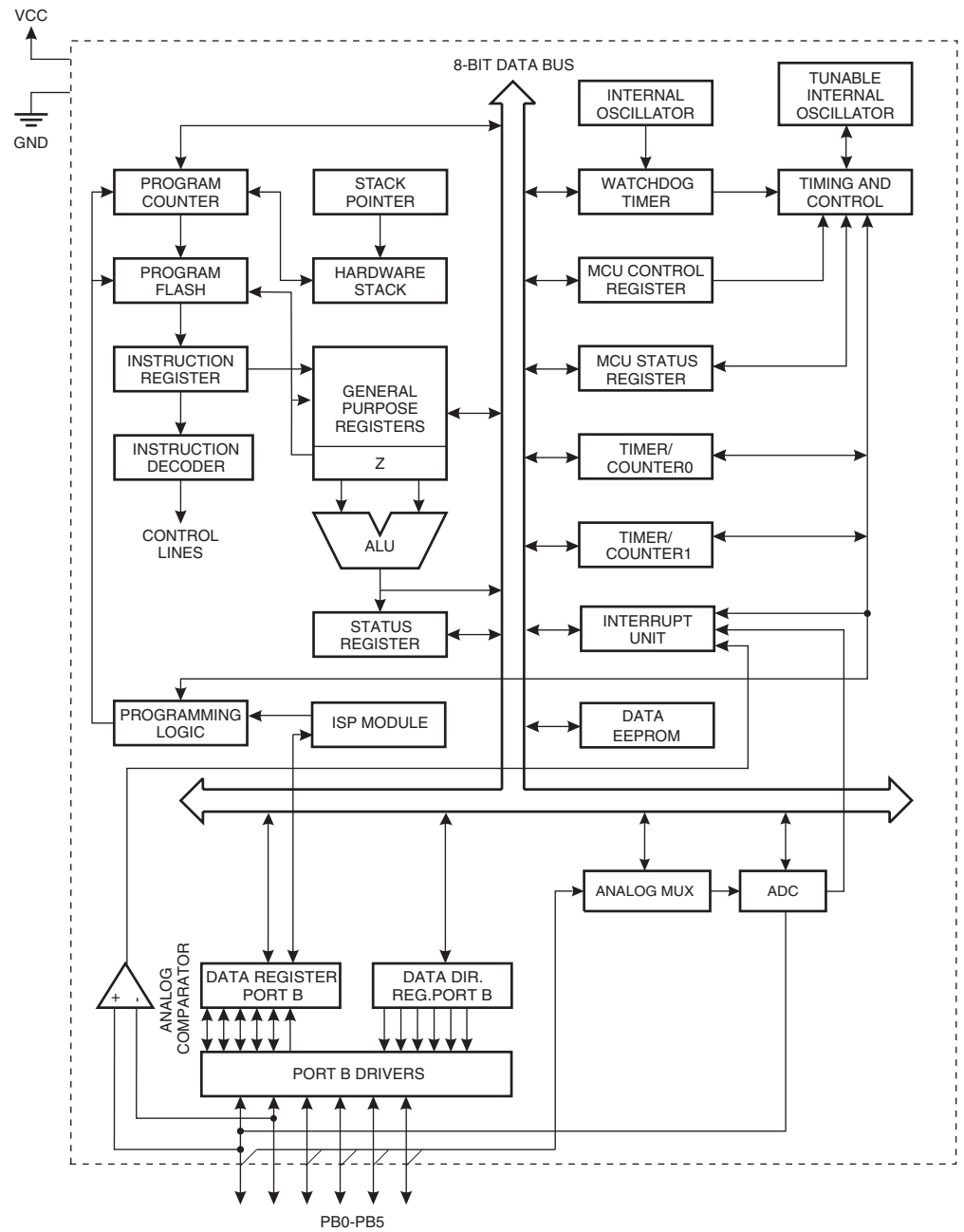

Pin Descriptions

VCC Supply voltage pin.

GND Ground pin.

Port B (PB5..PB0) Port B is a 6-bit I/O port. PB4..0 are I/O pins that can provide internal pull-ups (selected for each bit). PB5 is input or open-drain output. The use of pin PB5 is defined by a fuse and the special function associated with this pin is External Reset. The port pins are tri-stated when a reset condition becomes active, even if the clock is not running.

Port B also accommodates analog I/O pins. The Port B pins with alternate functions are shown in Table 1.

Table 1. Port B Alternate Functions

Port Pin	Alternate Function
PB0	MOSI (Data Input Line for Memory Downloading) AREF (ADC Voltage Reference) AIN0 (Analog Comparator Positive Input)
PB1	MISO (Data Output Line for Memory Downloading) OC1A (Timer/Counter PWM Output) AIN1 (Analog Comparator Negative Input)
PB2	SCK (Serial Clock Input for Serial Programming) INT0 (External Interrupt0 Input) ADC1 (ADC Input Channel 1) T0 (Timer/Counter0 External Counter Input)
PB3	ADC2 (ADC Input Channel 2)
PB4	ADC3 (ADC Input Channel 3)
PB5	$\overline{\text{RESET}}$ (External Reset Pin) ADC0 (ADC Input Channel 0)

Analog Pins Up to four analog inputs can be selected as inputs to Analog-to-Digital Converter (ADC).

Internal Oscillators The internal Oscillator provides a clock rate of nominally 1.6 MHz for the system clock (CK). Due to large initial variation (0.8 -1.6 MHz) of the internal Oscillator, a tuning capability is built in. Through an 8-bit control register – OSCCAL – the system clock rate can be tuned with less than 1% steps of the nominal clock.

There is an internal PLL that provides a 16x clock rate locked to the system clock (CK) for the use of the Peripheral Timer/Counter1. The nominal frequency of this peripheral clock, PCK, is 25.6 MHz.

ATtiny15L Architectural Overview

The fast-access Register File concept contains 32 x 8-bit general purpose working registers with a single-clock-cycle access time. This means that during one single clock cycle, one ALU (Arithmetic Logic Unit) operation is executed. Two operands are output from the Register File, the operation is executed, and the result is stored back in the Register File – in one clock cycle.

Two of the 32 registers can be used as a 16-bit pointer for indirect memory access. This pointer is called the Z-pointer, and can address the Register File, IO file and the Flash Program memory.

Figure 2. The ATtiny15L AVR RISC Architecture

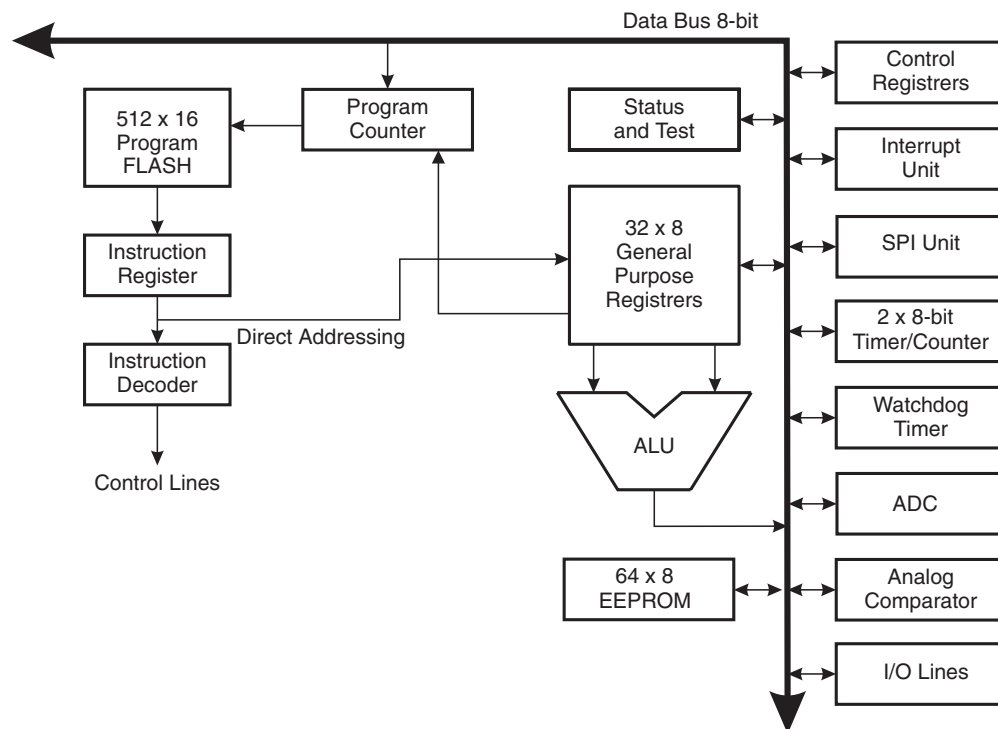

The ALU supports arithmetic and logic functions between registers or between a constant and a register. Single-register operations are also executed in the ALU. Figure 2 shows the ATtiny15L AVR RISC microcontroller architecture. The AVR uses a Harvard architecture concept with separate memories and buses for program and data memories. The program memory is accessed with a two-stage pipeline. While one instruction is being executed, the next instruction is pre-fetched from the program memory. This concept enables instructions to be executed in every clock cycle. The Program memory is In-System Programmable Flash memory.

With the relative jump and relative call instructions, the whole address space is directly accessed. All AVR instructions have a single 16-bit word format, meaning that every program memory address contains a single 16-bit instruction.

During interrupts and subroutine calls, the return address Program Counter (PC) is stored on the Stack. The Stack is a 3-level-deep Hardware Stack dedicated for subroutines and interrupts.

The I/O memory space contains 64 addresses for CPU peripheral functions as Control Registers, Timer/Counters and other I/O functions. The memory spaces in the AVR architecture are all linear and regular memory maps.

A flexible interrupt module has its control registers in the I/O space with an additional Global Interrupt Enable bit in the Status Register. All the different interrupts have a separate Interrupt Vector in the Interrupt Vector table at the beginning of the program memory. The different interrupts have priority in accordance with their Interrupt Vector position. The lower the Interrupt Vector address, the higher the priority.

The General Purpose Register File

Figure 3 shows the structure of the 32 general purpose registers in the CPU.

Figure 3. AVR CPU General Purpose Working Registers

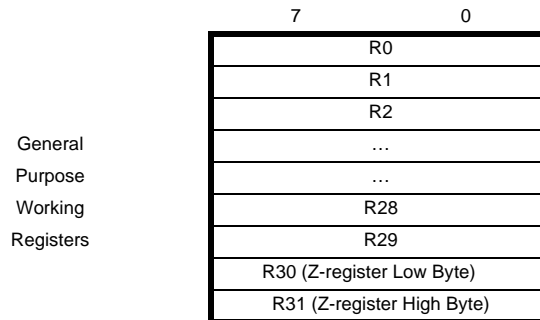

All the register operating instructions in the instruction set have direct- and single-cycle access to all registers. The only exception is the five constant arithmetic and logic instructions SBCI, SUBI, CPI, ANDI, and ORI between a constant and a register and the LDI instruction for load-immediate constant data. These instructions apply to the second half of the registers in the Register File – R16..R31. The general SBC, SUB, CP, AND, OR, and all other operations between two registers or on a single-register apply to the entire Register File.

Registers 30 and 31 form a 16-bit pointer (the Z-pointer) which is used for indirect Flash memory and Register File access. When the Register File is accessed, the contents of R31 is discarded by the CPU.

The ALU – Arithmetic Logic Unit

The high-performance AVR ALU operates in direct connection with all the 32 general purpose working registers. Within a single clock cycle, ALU operations between registers in the Register File are executed. The ALU operations are divided into three main categories – arithmetic, logic and bit-functions. Some microcontrollers in the AVR product family feature a hardware multiplier in the arithmetic part of the ALU.

The Flash Program Memory

The ATtiny15L contains 1K byte On-chip, In-System Programmable Flash memory for program storage. Since all instructions are single 16-bit words, the Flash is organized as 512 x 16 words. The Flash memory has an endurance of at least 1,000 write/erase cycles.

The ATtiny15L Program Counter is nine bits wide, thus addressing the 512 words Flash Program memory.

See page 54 for a detailed description on Flash memory programming.

The Program and Data Addressing Modes

The ATtiny15L AVR RISC Microcontroller supports powerful and efficient addressing modes. This section describes the various addressing modes supported in the ATtiny15L. In the figures, OP means the operation code part of the instruction word. To simplify, not all figures show the exact location of the addressing bits.

Register Direct, Single-register Rd

Figure 4. Direct Single-register Addressing

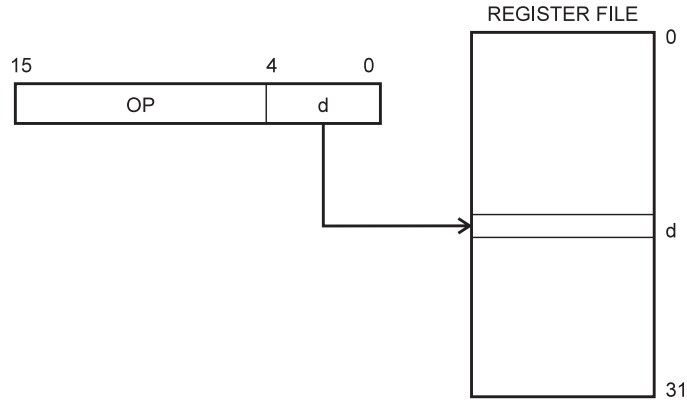

The operand is contained in register d (Rd).

Register Indirect

Figure 5. Indirect Register Addressing

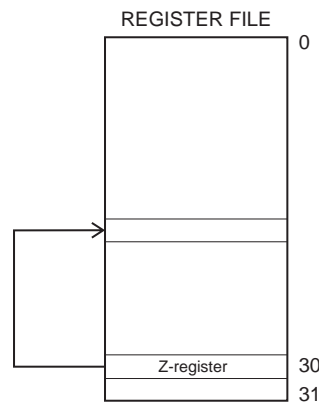

The register accessed is the one pointed to by the Z-register low byte (R30).

Register Direct, Two Registers Rd and Rr

Figure 6. Direct Register Addressing, Two Registers

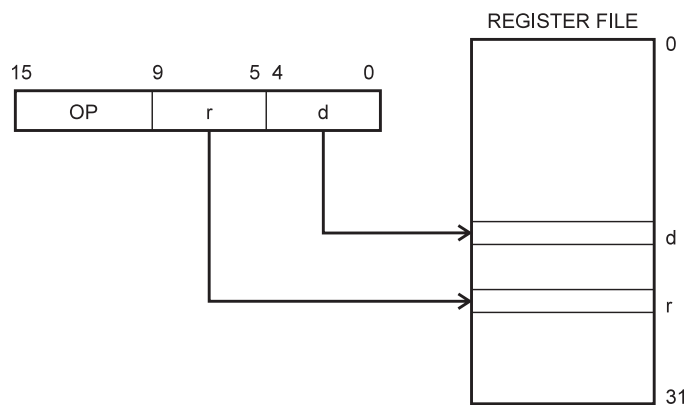

Operands are contained in register r (Rr) and d (Rd). The result is stored in register d (Rd).

I/O Direct

Figure 7. I/O Direct Addressing

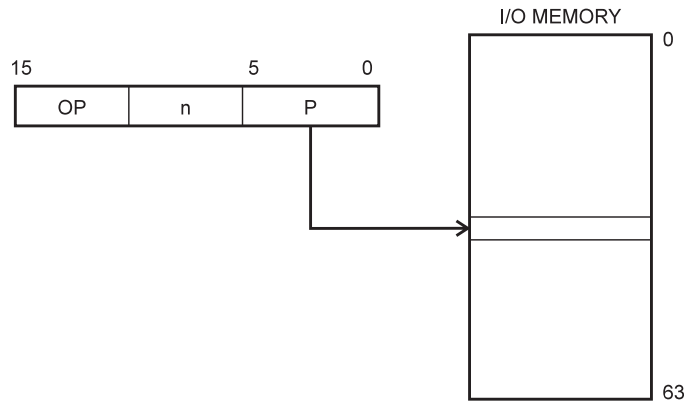

Operand address is contained in 6 bits of the instruction word. “n” is the destination or source register address.

Relative Program Addressing, RJMP and RCALL

Figure 8. Relative Program Memory Addressing

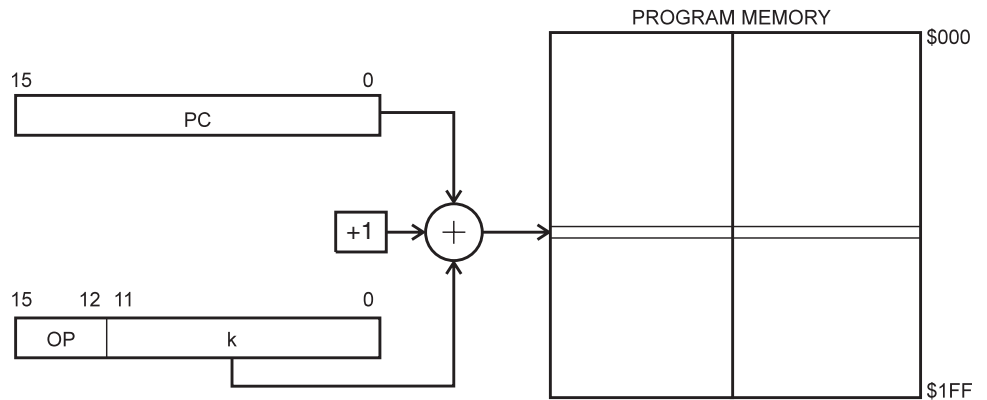

Program execution continues at address $PC + k + 1$. The relative address k is -2048 to 2047.

Constant Addressing using the LPM Instruction

Figure 9. Code Memory Constant Addressing

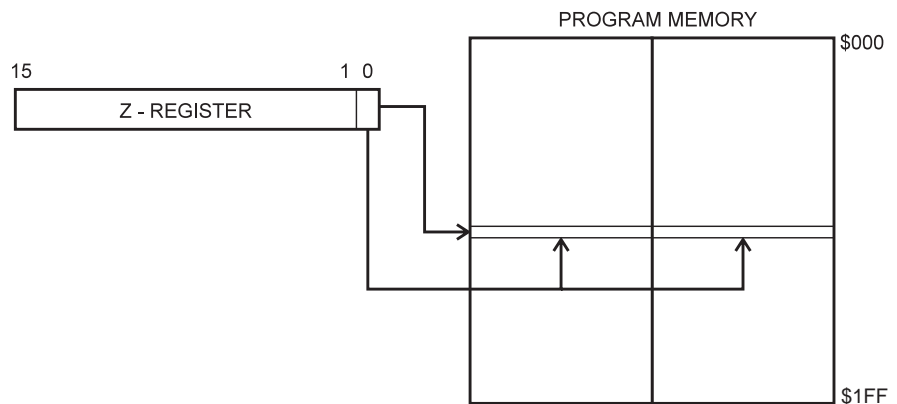

Constant byte address is specified by the Z-register contents. The 15 MSBs select word address (0 - 511), and LSB selects low byte if cleared (LSB = 0) or high byte if set (LSB = 1).

Subroutine and Interrupt Hardware Stack

The ATtiny15L uses a 3-level-deep Hardware Stack for subroutines and interrupts. The Hardware Stack is nine bits wide and stores the Program Counter (PC) return address while subroutines and interrupts are executed.

RCALL instructions and interrupts push the PC return address onto Stack level 0, and the data in the other Stack levels 1 - 2 are pushed one level deeper in the Stack. When a RET or RETI instruction is executed the returning PC is fetched from Stack level 0, and the data in the other Stack levels 1 - 2 are popped one level in the Stack.

If more than three subsequent subroutine calls or interrupts are executed, the first values written to the Stack are overwritten. Pushing four return addresses A1, A2, A3, and A4 followed by four subroutine or interrupt returns, will pop A4, A3, A2, and once more A2 from the Hardware Stack.

The EEPROM Data Memory

The ATtiny15L contains 64 bytes of data EEPROM memory. It is organized as a separate data space, in which single bytes can be read and written. The EEPROM has an endurance of at least 100,000 write/erase cycles. The access between the EEPROM and the CPU is described on page 36, specifying the EEPROM Address Register, the EEPROM Data Register, and the EEPROM Control Register.

Memory Access and Instruction Execution Timing

This section describes the general access timing concepts for instruction execution and internal memory access.

The AVR CPU is driven by the System Clock \emptyset , directly generated from the external clock crystal for the chip. No internal clock division is used.

Figure 10 shows the parallel instruction fetches and instruction executions enabled by the Harvard architecture and the fast-access Register File concept. This is the basic pipelining concept to obtain up to 1 MIPS per MHz with the corresponding unique results for functions per cost, functions per clocks, and functions per power-unit.

Figure 10. The Parallel Instruction Fetches and Instruction Executions

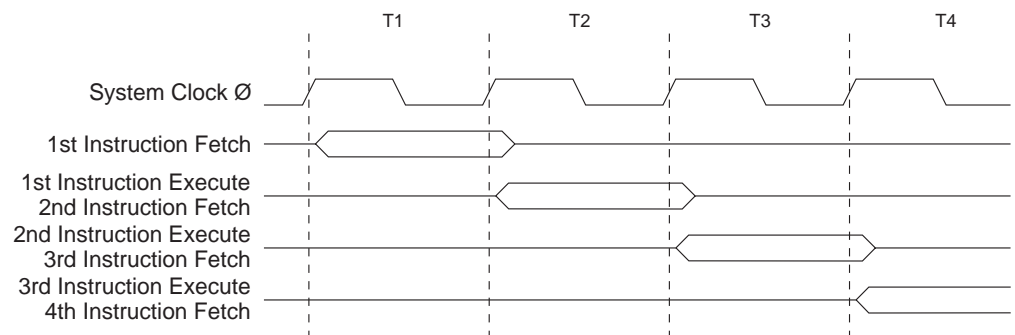
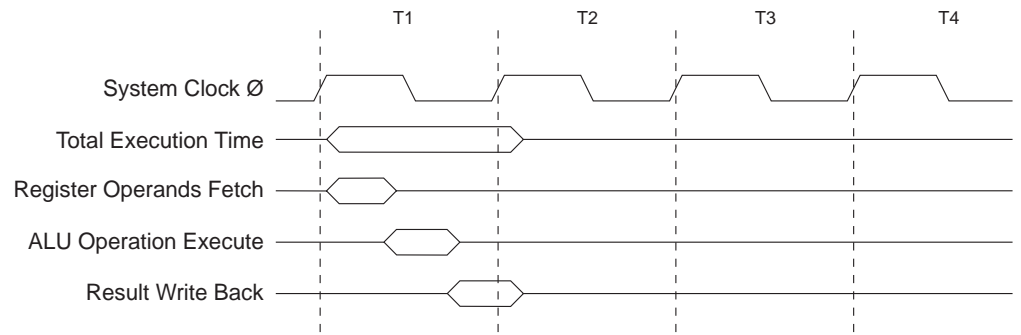

Figure 11 shows the internal timing concept for the Register File. In a single clock cycle an ALU operation using two register operands is executed, and the result is stored back to the destination register.

Figure 11. Single Cycle ALU Operation



I/O Memory

The I/O space definition of the ATtiny15L is shown in Table 2.

Table 2. ATtiny15L I/O Space⁽¹⁾

Address Hex	Name	Function
\$3F	SREG	Status Register
\$3B	GIMSK	General Interrupt Mask Register
\$3A	GIFR	General Interrupt Flag Register
\$39	TIMSK	Timer/Counter Interrupt Mask Register
\$38	TIFR	Timer/Counter Interrupt Flag Register
\$35	MCUCR	MCU Control Register
\$34	MCUSR	MCU Status Register
\$33	TCCR0	Timer/Counter0 Control Register
\$32	TCNT0	Timer/Counter0 (8-bit)
\$31	OSCCAL	Oscillator Calibration Register
\$30	TCCR1	Timer/Counter1 Control Register
\$2F	TCNT1	Timer/Counter1 (8-bit)
\$2E	OCR1A	Timer/Counter1 Output Compare Register A
\$2D	OCR1B	Timer/Counter1 Output Compare Register B
\$2C	SFIOR	Special Function I/O Register
\$21	WDTCR	Watchdog Timer Control Register
\$1E	EEAR	EEPROM Address Register
\$1D	EEDR	EEPROM Data Register
\$1C	EECR	EEPROM Control Register
\$18	PORTB	Data Register, Port B
\$17	DDRB	Data Direction Register, Port B
\$16	PINB	Input Pins, Port B
\$08	ACSR	Analog Comparator Control and Status Register
\$07	ADMUX	ADC Multiplexer Select Register

Table 2. ATtiny15L I/O Space⁽¹⁾ (Continued)

Address Hex	Name	Function
\$06	ADCSR	ADC Control and Status Register
\$05	ADCH	ADC Data Register High
\$04	ADCL	ADC Data Register Low

Note: 1. Reserved and unused locations are not shown in the table.

All ATtiny15L I/O and peripheral registers are placed in the I/O space. The I/O locations are accessed by the IN and OUT instructions transferring data between the 32 general purpose working registers and the I/O space. I/O Registers within the address range \$00 - \$1F are directly bit-accessible using the SBI and CBI instructions. In these registers, the value of single bits can be checked by using the SBIS and SBIC instructions. Refer to the instruction set chapter for more details. For compatibility with future devices, reserved bits should be written zero if accessed. Reserved I/O memory addresses should never be written.

The I/O and Peripheral Control Registers are explained in the following sections.

The Status Register – SREG

The AVR Status Register – SREG – at I/O space location \$3F is defined as:

Bit	7	6	5	4	3	2	1	0	
\$3F	I	T	H	S	V	N	Z	C	SREG
Read/Write	R/W	R/W	R/W	R/W	R/W	R/W	R/W	R/W	
Initial Value	0	0	0	0	0	0	0	0	

- **Bit 7 – I: Global Interrupt Enable**

The Global Interrupt Enable bit must be set (one) for the interrupts to be enabled. The individual interrupt enable control is then performed in the Interrupt Mask Registers – GIMSK and TIMSK. If the Global Interrupt Enable Register is cleared (zero), none of the interrupts are enabled independent of the GIMSK and TIMSK values. The I-bit is cleared by hardware after an interrupt has occurred, and is set by the RETI instruction to enable subsequent interrupts.

- **Bit 6 – T: Bit Copy Storage**

The Bit Copy instructions BLD (Bit LoaD) and BST (Bit STore) use the T-bit as source and destination for the operated bit. A bit from a register in the Register File can be copied into T by the BST instruction, and a bit in T can be copied into a bit in a register in the Register File by the BLD instruction.

- **Bit 5 – H: Half-carry Flag**

The Half-carry Flag H indicates a half-carry in some arithmetic operations. See the Instruction Set description for detailed information.

- **Bit 4 – S: Sign Bit, $S = N \oplus V$**

The S-bit is always an exclusive or between the Negative Flag N and the Two's Complement Overflow Flag V. See the Instruction Set description for detailed information.

- **Bit 3 – V: Two's Complement Overflow Flag**

The Two's Complement Overflow Flag V supports two's complement arithmetics. See the Instruction Set description for detailed information.

- **Bit 2 – N: Negative Flag**

The Negative Flag N indicates a negative result after the different arithmetic and logic operations. See the Instruction Set description for detailed information.

- **Bit 1 – Z: Zero Flag**

The Zero Flag Z indicates a zero result after the different arithmetic and logic operations. See the Instruction Set description for detailed information.

- **Bit 0 – C: Carry Flag**

The Carry Flag C indicates a carry in an arithmetic or logic operation. See the Instruction Set description for detailed information.

Reset and Interrupt Handling

The ATtiny15L provides eight interrupt sources. These interrupts and the separate Reset Vector each have a separate Program Vector in the Program memory space. All the interrupts are assigned individual enable bits that must be set (one) together with the I-bit in the Status Register in order to enable the interrupt.

The lowest addresses in the Program memory space are automatically defined as the Reset and Interrupt Vectors. The complete list of vectors is shown in Table 3. The list also determines the priority levels of the different interrupts. The lower the address the higher is the priority level. RESET has the highest priority, and next is INT0 (the External Interrupt Request 0), etc.

Table 3. Reset and Interrupt Vectors

Vector No.	Program Address	Source	Interrupt Definition
1	\$000	RESET	External Reset, Power-on Reset, Brown-out Reset, and Watchdog Reset
2	\$001	INT0	External Interrupt Request 0
3	\$002	I/O Pins	Pin Change Interrupt
4	\$003	TIMER1, COMPA	Timer/Counter1 Compare Match A
5	\$004	TIMER1, OVF	Timer/Counter1 Overflow
6	\$005	TIMER0, OVF	Timer/Counter0 Overflow
7	\$006	EE_RDY	EEPROM Ready
8	\$007	ANA_COMP	Analog Comparator
9	\$008	ADC	ADC Conversion Complete

The most typical and general program setup for the Reset and Interrupt Vector Addresses are:

Address	Labels	Code	Comments
\$000		rjmp RESET	; Reset handler
\$001		rjmp EXT_INT0	; IRQ0 handler
\$002		rjmp PIN_CHANGE	; Pin change handler
\$003		rjmp TIM1_CMP	; Timer1 compare match
\$004		rjmp TIM1_OVF	; Timer1 overflow handler
\$005		rjmp TIM0_OVF	; Timer0 overflow handler
\$006		rjmp EE_RDY	; EEPROM Ready handler
\$007		rjmp ANA_COMP	; Analog Comparator handler
\$008		rjmp ADC	; ADC Conversion Handler
		;	
\$009	MAIN:	<instr> xxx	; Main program start
...

ATtiny15L Reset Sources

The ATtiny15L has four sources of Reset:

- Power-on Reset. The MCU is reset when the supply voltage is below the Power-on Reset threshold (V_{POR}).
- External Reset. The MCU is reset when a low-level is present on the \overline{RESET} pin for more than 500 ns.
- Watchdog Reset. The MCU is reset when the Watchdog Timer period expires, and the Watchdog is enabled.
- Brown-out Reset. The MCU is reset when the supply voltage V_{CC} is below the Brown-out Reset threshold (V_{BOT}).

During Reset, all I/O Registers are then set to their initial values, and the program starts execution from address \$000. The instruction placed in address \$000 must be an Rjmp (relative jump) instruction to the reset handling routine. If the program never enables an interrupt source, the Interrupt Vectors are not used, and regular program code can be placed at these locations. The circuit diagram in Figure 12 shows the reset logic. Table 4 and Table 5 define the timing and electrical parameters of the reset circuitry. Note that the Register File is unchanged by a reset.

Figure 12. Reset Logic

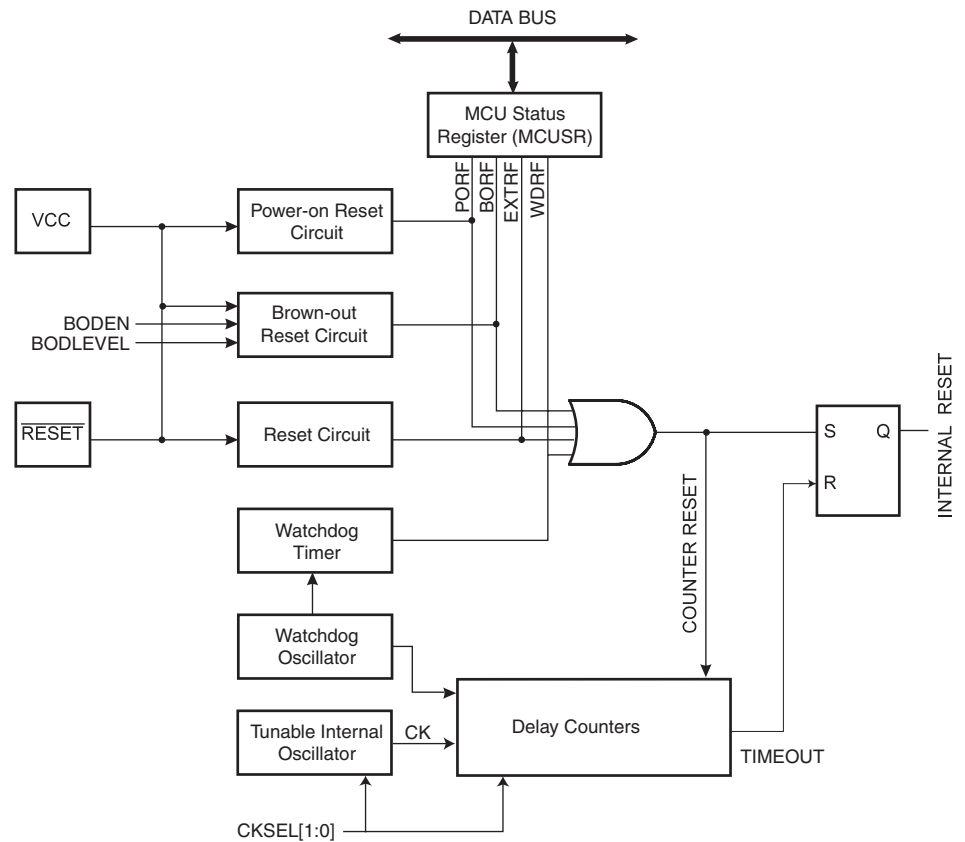

Table 4. Reset Characteristics ($V_{CC} = 5.0V$)⁽¹⁾

Symbol	Parameter	Condition	Min	Typ	Max	Units
V_{POT}	Power-on Reset Threshold Voltage (rising)	BOD disabled	1.0	1.4	1.8	V
		BOD enabled	1.7	2.2	2.7	V
	Power-on Reset Threshold Voltage (falling) ⁽¹⁾	BOD disabled	0.4	0.6	0.8	V
		BOD enabled	1.7	2.2	2.7	V
V_{RST}	\overline{RESET} Pin Threshold Voltage		–	–	$0.85 V_{CC}$	V
V_{BOT}	Brown-out Reset Threshold Voltage	(BODLEVEL = 1)	2.3	2.7	2.9	V
		(BODLEVEL = 0)	3.4	4.0	4.3	V

Note: 1. The Power-on Reset will not work unless the supply voltage has been below V_{POT} (falling).

Table 5. Reset Delay Selections⁽¹⁾

BODEN ⁽²⁾	CKSEL [1:0] ⁽²⁾	Start-up Time, t_{TOUT} at $V_{CC} = 2.7V$	Start-up Time, t_{TOUT} at $V_{CC} = 5.0V$	Recommended Usage
x	00	256 ms + 18 CK	64 ms + 18 CK	BOD disabled, slowly rising power
x	01	256 ms + 18 CK	64 ms + 18 CK	BOD disabled, slowly rising power
x	10	16 ms + 18 CK	4 ms + 18 CK	BOD disabled, quickly rising power
1	11	18 CK + 32 μ s	18 CK + 8 μ s	BOD disabled
0	11	18 CK + 128 μ s	18 CK + 32 μ s	BOD enabled

- Notes: 1. On Power-up, the start-up time is increased with typical 0.6 ms.
 2. "0" means programmed, "1" means unprogrammed.

Table 5 shows the start-up times from Reset. When the CPU wakes up from Power-down, only the clock-counting part of the start-up time is used. The Watchdog Oscillator is used for timing the real-time part of the start-up time. The number Watchdog Oscillator cycles used for each time-out is shown in Table 6.

The frequency of the Watchdog Oscillator is voltage dependent as shown in the Electrical Characteristics section on page 64. The device is shipped with CKSEL = "00".

Table 6. Number of Watchdog Oscillator Cycles

V_{CC} Conditions	Time-out	Number of Cycles
2.7V	32 μ s	8
2.7V	128 μ s	32
2.7V	16 ms	4K
2.7V	256 ms	64K
5.0V	8 μ s	8
5.0V	32 μ s	32
5.0V	4 ms	4K
5.0V	64 ms	64K

Power-on Reset

A Power-on Reset (POR) pulse is generated by an On-chip Detection circuit. The detection level is nominally defined in Table 4. The POR is activated whenever V_{CC} is below the detection level. The POR circuit can be used to trigger the Start-up Reset, as well as detect a failure in supply voltage.

A Power-on Reset (POR) circuit ensures that the device is Reset from Power-on. Reaching the Power-on Reset threshold voltage invokes a delay counter, which determines the delay, for which the device is kept in RESET after V_{CC} rise. The Time-out period of the delay counter can be defined by the user through the CKSEL Fuses. The different selections for the delay period are presented in Table 5. The RESET signal is activated again, without any delay, when the V_{CC} decreases below detection level.

Figure 13. “MCU Start-up, $\overline{\text{RESET}}$ Tied to V_{CC}

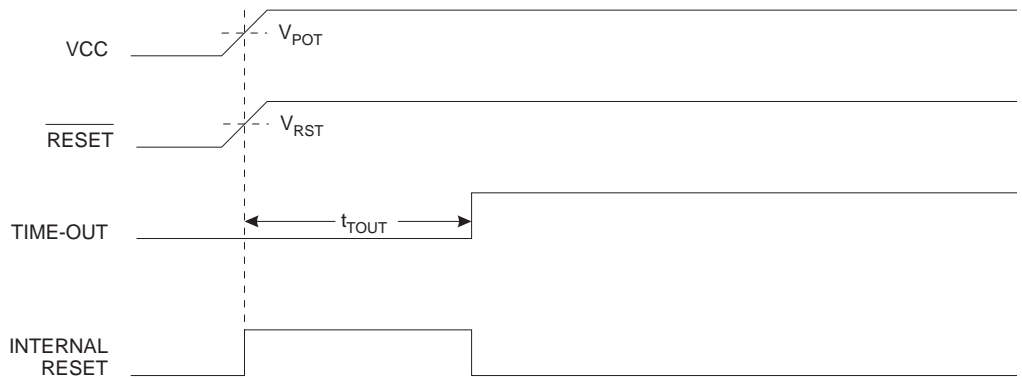
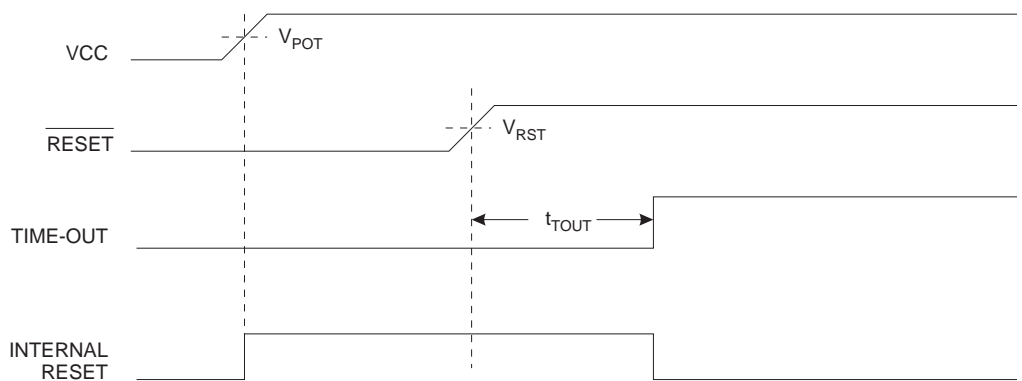

Figure 14. MCU Start-up, $\overline{\text{RESET}}$ Extended Externally



External Reset

An External Reset is generated by a low-level on the $\overline{\text{RESET}}$ pin. Reset pulses longer than 500 ns will generate a reset, even if the clock is not running. Shorter pulses are not guaranteed to generate a reset. When the applied signal reaches the Reset Threshold Voltage (V_{RST}) on its positive edge, the delay timer starts the MCU after the Time-out period t_{TOUT} has expired.

Figure 15. External Reset during Operation

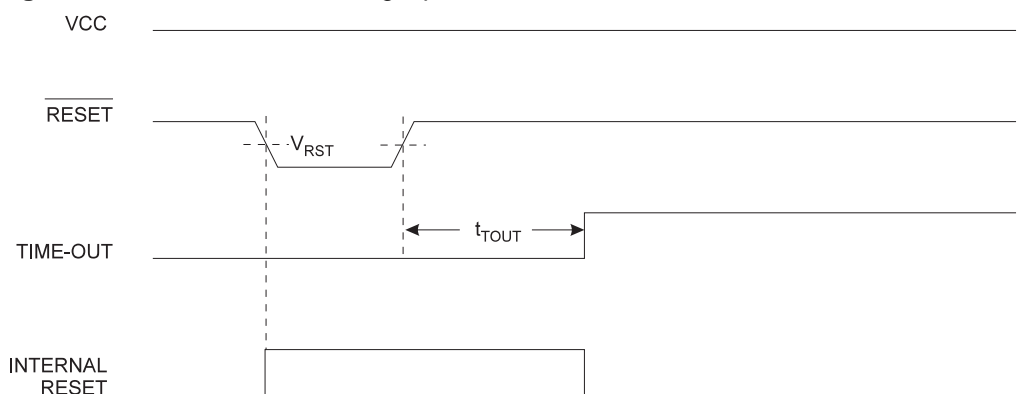

Brown-out Detection

ATtiny15L has an On-chip Brown-out Detection (BOD) circuit for monitoring the V_{CC} level during the operation. The BOD circuit can be enabled/disabled by the fuse BODEN. When BODEN is enabled (BODEN programmed), and V_{CC} decreases below the trigger level, the Brown-out Reset is immediately activated. When V_{CC} increases above the trigger level, the Brown-out Reset is deactivated after a delay. The delay is defined by the user in the same way as the delay of POR signal, in Table 5. The trigger level for the BOD can be selected by the fuse BODLEVEL to be 2.7V (BODLEVEL unprogrammed), or 4.0V (BODLEVEL programmed). The trigger level has a hysteresis of 50 mV to ensure spike-free Brown-out Detection.

The BOD circuit will only detect a drop in V_{CC} if the voltage stays below the trigger level for longer than 3 μ s for trigger level 4.0V, 7 μ s for trigger level 2.7V (typical values).

Figure 16. Brown-out Reset during Operation⁽¹⁾

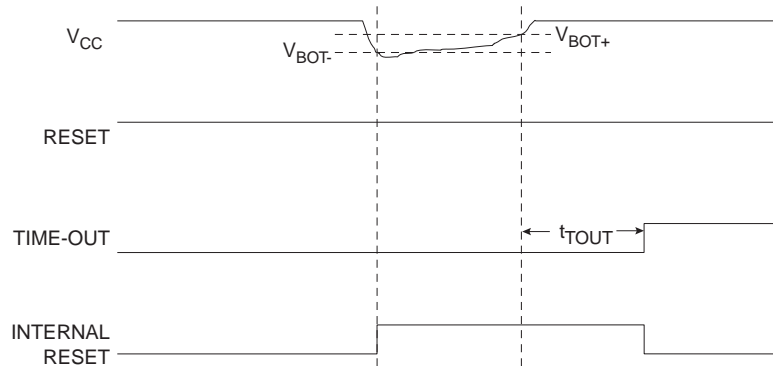

Note: 1. The hysteresis on V_{BOT} : $V_{BOT+} = V_{BOT} + 25$ mV, $V_{BOT-} = V_{BOT} - 25$ mV.

Watchdog Reset

When the Watchdog times out, it will generate a short reset pulse of one CK cycle duration. On the falling edge of this pulse, the delay timer starts counting the Time-out period t_{TOUT} . Refer to page 34 for details on operation of the Watchdog Timer.

Figure 17. Watchdog Reset during Operation

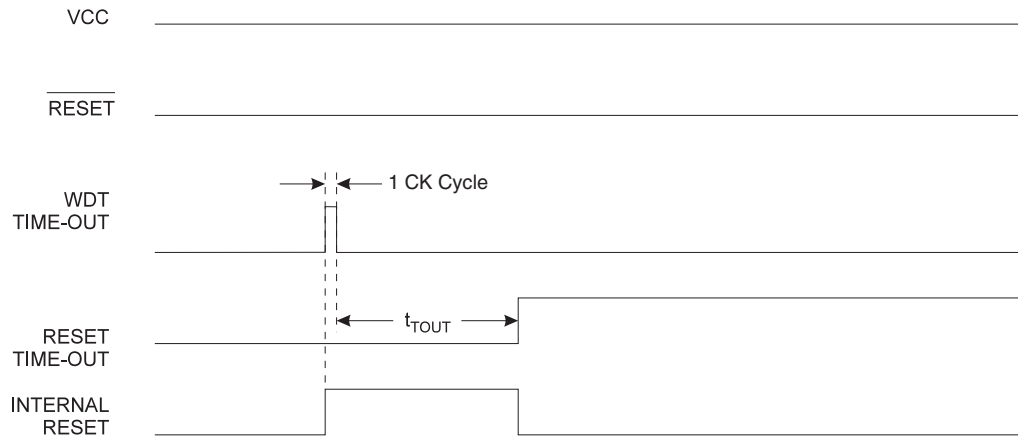

MCU Status Register – MCUSR

The MCU Status Register provides information on which reset source caused an MCU Reset.

Bit	7	6	5	4	3	2	1	0	
\$34	–	–	–	–	WDRF	BORF	EXTRF	PORF	MCUSR
Read/Write	R	R	R	R	R/W	R/W	R/W	R/W	
Initial Value	0	0	0	0				See Bit Description	

- **Bit 7..4 – Res: Reserved Bits**

These bits are reserved bits in the ATtiny15L and always read as zero.

- **Bit 3 – WDRF: Watchdog Reset Flag**

This bit is set (one) if a Watchdog Reset occurs. The bit is reset (zero) by a Power-on Reset, or by writing a logical “0” to the flag.

- **Bit 2 – BORF: Brown-out Reset Flag**

This bit is set (one) if a Brown-out Reset occurs. The bit is reset (zero) by a Power-on Reset, or by writing a logical “0” to the flag.

- **Bit 1 – EXTRF: External Reset Flag**

This bit is set (one) if a External Reset occurs. The bit is reset (zero) by a Power-on Reset, or by writing a logical “0” to the flag.

- **Bit 0 – PORF: Power-on Reset Flag**

This bit is set (one) if a Power-on Reset occurs. The bit is reset (zero) by writing a logical “0” to the flag.

To make use of the Reset Flags to identify a reset condition, the user should read and then reset the MCUSR as early as possible in the program. If the register is cleared before another reset occurs, the source of the reset can be found by examining the Reset Flags.

Internal Voltage Reference

ATtiny15L features an internal bandgap reference with a nominal voltage of 1.22V. This reference is used for Brown-out Detection, and it can be used as an input to the Analog Comparator. The 2.56V reference to the ADC is generated from the internal bandgap reference.

Voltage Reference Enable Signals and Start-up Time

The voltage reference has a start-up time that may influence the way it should be used. The maximum start-up time is 10 μ s. To save power, the reference is not always turned on. The reference is on during the following situations:

1. When the BOD is enabled (by programming the BODEN Fuse).
2. When the bandgap reference is connected to the Analog Comparator (by setting the AINBG bit in ACSR).
3. When the ADC is enabled.

Thus, when the BOD is not enabled, after setting the AINBG bit, the user must always allow the reference to start-up before the output from the Analog Comparator is used. The bandgap reference uses typically 10 μ A, and to reduce power consumption in Power-down mode, the user can avoid the three conditions above to ensure that the reference is turned off before entering Power-down mode.

Interrupt Handling

The ATtiny15L has two 8-bit Interrupt Mask Control Registers: GIMSK (General Interrupt Mask Register) and TIMSK (Timer/Counter Interrupt Mask Register).

When an interrupt occurs, the Global Interrupt Enable I-bit is cleared (zero) and all interrupts are disabled. The user software can set the I-bit (one) to enable interrupts. The I-bit is set (one) when a Return from Interrupt instruction (RETI) is executed.

When the Program Counter is vectored to the actual Interrupt Vector in order to execute the interrupt handling routine, hardware clears the corresponding flag that generated the interrupt. Some of the interrupt flags can also be cleared by writing a logical “1” to the flag bit position(s) to be cleared.

If an interrupt condition occurs when the corresponding interrupt enable bit is cleared (zero), the interrupt flag will be set and remembered until the interrupt is enabled, or the flag is cleared by software.

If one or more interrupt conditions occur when the global interrupt enable bit is cleared (zero), the corresponding interrupt flag(s) will be set and remembered until the global interrupt enable bit is set (one), and will be executed by order of priority.

Note that external level interrupt does not have a flag, and will only be remembered for as long as the interrupt condition is present.

Note that the Status Register is not automatically stored when entering an interrupt routine and restored when returning from an interrupt routine. This must be handled by software.

Interrupt Response Time

The interrupt execution response for all the enabled AVR interrupts is four clock cycles minimum. After the four clock cycles the Program Vector address for the actual interrupt handling routine is executed. During this 4-clock-cycle period, the Program Counter (nine bits) is pushed onto the Stack. The vector is often a relative jump to the interrupt routine, and this jump takes two clock cycles. If an interrupt occurs during execution of a multi-cycle instruction, this instruction is completed before the interrupt is served. If an interrupt occurs when the MCU is in sleep mode, the interrupt execution response time is increased by four clock cycles.

A return from an interrupt handling routine takes four clock cycles. During these four clock cycles, the Program Counter (nine bits) is popped back from the Stack. When AVR exits from an interrupt, it will always return to the main program and execute one more instruction before any pending interrupt is served.

The General Interrupt Mask Register – GIMSK

Bit	7	6	5	4	3	2	1	0	
\$3B	–	INT0	PCIE	–	–	–	–	–	GIMSK
Read/Write	R	R/W	R/W	R	R	R	R	R	
Initial Value	0	0	0	0	0	0	0	0	

- **Bit 7 – Res: Reserved Bit**

This bit is a reserved bit in the ATtiny15L and always reads as zero.

- **Bit 6 – INT0: External Interrupt Request 0 Enable**

When the INT0 bit is set (one) and the I-bit in the Status Register (SREG) is set (one), the external pin interrupt is activated. The Interrupt Sense Control0 bits 1/0 (ISC01 and ISC00) in the MCU general Control Register (MCUCR) define whether the external interrupt is activated on rising or falling edge, on pin change, or low level of the INT0 pin. Activity on the pin will cause an interrupt request even if INT0 is configured as an output.



The corresponding interrupt of External Interrupt Request 0 is executed from Program memory address \$001. See also “External Interrupts.”

- **Bit 5 – PCIE: Pin Change Interrupt Enable**

When the PCIE bit is set (one) and the I-bit in the Status Register (SREG) is set (one), the interrupt on pin change is enabled. Any change on any input or I/O pin will cause an interrupt. The corresponding interrupt of Pin Change Interrupt Request is executed from Program memory address \$002. See also “Pin Change Interrupt.”

- **Bits 4..0 – Res: Reserved Bits**

These bits are reserved bits in the ATtiny15L and always read as zero.

The General Interrupt Flag Register – GIFR

Bit	7	6	5	4	3	2	1	0	
\$3A	–	INTF0	PCIF	–	–	–	–	–	GIFR
Read/Write	R	R/W	R/W	R	R	R	R	R	
Initial Value	0	0	0	0	0	0	0	0	

- **Bit 7 – Res: Reserved Bit**

This bit is a reserved bit in the ATtiny15L and always reads as zero.

- **Bit 6 – INTF0: External Interrupt Flag0**

When an edge or logic change on the INT0 pin triggers an interrupt request, INTF0 becomes set (one). If the I-bit in SREG and the INT0 bit in GIMSK are set (one), the MCU will jump to the Interrupt Vector at address \$001. The flag is cleared when the interrupt routine is executed. Alternatively, the flag can be cleared by writing a logical “1” to it. The flag is always cleared when INT0 is configured as level interrupt.

- **Bit 5 – PCIF: Pin Change Interrupt Flag**

When an event on any input or I/O pin triggers an interrupt request, PCIF becomes set (one). If the I-bit in SREG and the PCIE bit in GIMSK are set (one), the MCU will jump to the Interrupt Vector at address \$002. The flag is cleared when the interrupt routine is executed. Alternatively, the flag can be cleared by writing a logical “1” to it.

- **Bits 4..0 – Res: Reserved Bits**

These bits are reserved bits in the ATtiny15L and always read as zero.

The Timer/Counter Interrupt Mask Register – TIMSK

Bit	7	6	5	4	3	2	1	0	
\$39	–	OCIE1A	–	–	–	TOIE1	TOIE0	–	TIMSK
Read/Write	R	R/W	R	R	R	R/W	R/W	R	
Initial Value	0	0	0	0	0	0	0	0	

- **Bit 7 – Res: Reserved Bit**

This bit is a reserved bit in the ATtiny15L and always reads as zero.

- **Bit 6 – OCIE1A: Timer/Counter1 Output Compare Interrupt Enable**

When the OCIE1A bit is set (one) and the I-bit in the Status Register is set (one), the Timer/Counter1 Compare Match, interrupt is enabled. The corresponding interrupt (at

vector \$003) is executed if a compare match A in Timer/Counter1 occurs, i.e., when the OCF1A bit is set (one) in the Timer/Counter Interrupt Flag Register (TIFR).

- **Bit 5..3 – Res: Reserved Bits**

These bits are reserved bits in the ATtiny15L and always read as zero.

- **Bit 2 – TOIE1: Timer/Counter1 Overflow Interrupt Enable**

When the TOIE1 bit is set (one) and the I-bit in the Status Register is set (one), the Timer/Counter1 Overflow interrupt is enabled. The corresponding interrupt (at vector \$004) is executed if an overflow in Timer/Counter1 occurs, i.e., when the TOV1 bit is set (one) in the Timer/Counter Interrupt Flag Register (TIFR).

- **Bit 1 – TOIE0: Timer/Counter0 Overflow Interrupt Enable**

When the TOIE0 bit is set (one) and the I-bit in the Status Register is set (one), the Timer/Counter0 Overflow interrupt is enabled. The corresponding interrupt (at vector \$005) is executed if an overflow in Timer/Counter0 occurs, i.e., when the TOV0 bit is set (one) in the Timer/Counter Interrupt Flag Register (TIFR).

- **Bit 0 – Res: Reserved Bit**

This bit is a reserved bit in the ATtiny15L and always reads as zero.

The Timer/Counter Interrupt Flag Register – TIFR

Bit	7	6	5	4	3	2	1	0	
\$38	–	OCF1A	–	–	–	TOV1	TOV0	–	TIFR
Read/Write	R	R/W	R	R	R	R/W	R/W	R	
Initial Value	0	0	0	0	0	0	0	0	

- **Bit 7 – Res: Reserved Bit**

This bit is a reserved bit in the ATtiny15L and always reads as zero.

- **Bit 6 – OCF1A: Output Compare Flag 1A**

The OCF1A bit is set (one) when compare match occurs between Timer/Counter1 and the data value in OCR1A (Output Compare Register 1A). OCF1A is cleared by hardware when executing the corresponding interrupt handling vector. Alternatively, OCF1A is cleared by writing a logical “1” to the flag. When the I-bit in SREG, OCIE1A, and OCF1A are set (one), the Timer/Counter1 compare match A interrupt is executed.

- **Bits 5..3 – Res: Reserved bits**

These bits are reserved bits in the ATtiny15L and always read as zero.

- **Bit 2 – TOV1: Timer/Counter1 Overflow Flag**

The bit TOV1 is set (one) when an overflow occurs in Timer/Counter1. TOV1 is cleared by hardware when executing the corresponding interrupt handling vector. Alternatively, TOV1 is cleared by writing a logical “1” to the flag. When the SREG I-bit, TOIE1 (Timer/Counter1 Overflow Interrupt Enable) and TOV1 are set (one), the Timer/Counter1 Overflow Interrupt is executed.

- **Bit 1 – TOV0: Timer/Counter0 Overflow Flag**

The bit TOV0 is set (one) when an overflow occurs in Timer/Counter0. TOV0 is cleared by hardware when executing the corresponding interrupt handling vector. Alternatively, TOV0 is cleared by writing a logical “1” to the flag. When the SREG I-bit, TOIE0 (Timer/Counter0 Overflow Interrupt Enable) and TOV0 are set (one), the Timer/Counter0 Overflow interrupt is executed.

- **Bit 0 – Res: Reserved Bit**

This bit is a reserved bit in the ATtiny15L and always reads as zero.

External Interrupt

The External Interrupt is triggered by the INT0 pin. Observe that, if enabled, the interrupt will trigger even if the INT0 pin is configured as an output. This feature provides a way of generating a software interrupt. The External Interrupt can be triggered by a falling or rising edge, a pin change, or a low level. This is set up as indicated in the specification for the MCU Control Register (MCUCR). When the external interrupt is enabled and is configured as level-triggered, the interrupt will trigger as long as the pin is held low.

The External Interrupt is set up as described in the specification for the MCU Control Register (MCUCR).

Pin Change Interrupt

The pin change interrupt is triggered by any change in logical value on any input or I/O pin. Change on pins PB4..0 will always cause an interrupt. Change on pin PB5 will cause an interrupt if the pin is configured as input or I/O, as described in the section “Pin Descriptions” on page 4. Observe that, if enabled, the interrupt will trigger even if the changing pin is configured as an output. This feature provides a way of generating a software interrupt. Also observe that the pin change interrupt will trigger even if the pin activity triggers another interrupt, for example the external interrupt. This implies that one external event might cause several interrupts. The values on the pins are sampled before detecting edges. If pin change interrupt is enabled, pulses that last longer than one CPU clock period will generate an interrupt. Shorter pulses are not guaranteed to generate an interrupt.

The MCU Control Register – MCUCR

The MCU Control Register contains control bits for general MCU functions.

Bit	7	6	5	4	3	2	1	0	
\$35	–	PUD	SE	SM1	SM0	–	ISC01	ISC00	MCUCR
Read/Write	R	R/W	R/W	R/W	R/W	R	R/W	R/W	
Initial Value	0	0	0	0	0	0	0	0	

- **Bits 7 – Res: Reserved Bit**

This bit is a reserved bit in the ATtiny15L and always reads as zero.

- **Bit 6- PUD: Pull-up Disable**

This PUD bit must be set (one) to disable internal pull-up registers at Port B.

- **Bit 5 – SE: Sleep Enable**

The SE bit must be set (one) to make the MCU enter the sleep mode when the SLEEP instruction is executed. To avoid the MCU entering the sleep mode unless it is the programmer’s purpose, it is recommended to set the Sleep Enable SE bit just before the execution of the SLEEP instruction.

- **Bits 4, 3 – SM1, SM0: Sleep Mode Select Bits 1 and 0**

These bits select between the three available sleep modes, as shown in Table 7.

Table 7. Sleep Modes

SM1	SM0	Sleep Mode
0	0	Idle mode
0	1	ADC Noise Reduction mode
1	0	Power-down mode
1	1	Reserved

For details, refer to “Sleep Modes” below.

- **Bit 2 – Res: Reserved Bit**

This bit is a reserved bit in the ATtiny15L and always reads as zero.

- **Bits 1, 0 – ISC01, ISC00: Interrupt Sense Control 0 Bit 1 and Bit 0**

The External Interrupt 0 is activated by the external pin INT0 if the SREG I-flag and the corresponding interrupt mask is set (one). The activity on the external INT0 pin that activates the interrupt is defined in Table 8:

Table 8. Interrupt 0 Sense Control⁽¹⁾

ISC01	ISC00	Description
0	0	The low level of INT0 generates an interrupt request.
0	1	Any change on INT0 generates an interrupt request
1	0	The falling edge of INT0 generates an interrupt request.
1	1	The rising edge of INT0 generates an interrupt request.

Note: 1. When changing the ISC10/ISC00 bits, INT0 must be disabled by clearing its Interrupt Enable bit in the GIMSK Register. Otherwise an interrupt can occur when the bits are changed.

Sleep Modes

To enter any of the three sleep modes, the SE bit in MCUCR must be set (one) and a SLEEP instruction must be executed. The SM1 and SM0 bits in the MCUCR Register select which sleep mode (Idle, ADC Noise Reduction or Power-down) will be activated by the SLEEP instruction (see Table 7). If an enabled interrupt occurs while the MCU is in a sleep mode, the MCU wakes up. The MCU is then halted for four cycles, executes the interrupt routine and resumes execution from the instruction following SLEEP. On wake-up from Power-down mode on pin change, two instruction cycles are executed before the Pin Change Interrupt Flag is updated. The contents of the Register File, SRAM, and I/O memory are unaltered when the device wakes up from sleep. If a reset occurs during sleep mode, the MCU wakes up and executes from the Reset Vector.

Idle Mode

When the SM1/SM0 bits are “00”, the SLEEP instruction forces the MCU into the Idle mode, stopping the CPU but allowing the ADC, Analog Comparator, Timer/Counters, Watchdog and the Interrupt system to continue operating. This enables the MCU to wake-up from external triggered interrupts as well as internal ones like the Timer Overflow Interrupt and Watchdog Reset. If the ADC is enabled, a conversion starts automatically when this mode is entered. If wake-up from the Analog Comparator interrupt is not required, the Analog Comparator can be powered down by setting the ADC-bit in the Analog Comparator Control and Status Register (ACSR). This will reduce power consumption in Idle mode.



ADC Noise Reduction Mode

When the SM1/SM0 bits are “01”, the SLEEP instruction forces the MCU into the ADC Noise Reduction mode, stopping the CPU but allowing the ADC, the external interrupt pin, pin change interrupt and the Watchdog (if enabled) to continue operating. Please note that the clock system including the PLL is also active in the ADC Noise Reduction mode. This improves the noise environment for the ADC, enabling higher resolution measurements. If the ADC is enabled, a conversion starts automatically when this mode is entered. In addition to Watchdog Time-out and External Reset, only an external level-triggered interrupt, a pin change interrupt or an ADC interrupt can wake up the MCU.

Power-down Mode

When the SM1/SM0 bits are “10”, the SLEEP instruction forces the MCU into the Power-down mode. Only an External Reset, a Watchdog Reset (if enabled), an external level-triggered interrupt, or a pin change interrupt can wake up the MCU.

Note that if a level-triggered or pin change interrupt is used for wake-up from Power-down mode, the changed level must be held for some time to wake up the MCU. This makes the MCU less sensitive to noise. The changed level is sampled twice by the Watchdog Oscillator clock, and if the input has the required level during this time, the MCU will wake up. The period of the Watchdog Oscillator is 2.9 μ s (nominal) at 3.0V and 25°C. The frequency of the Watchdog Oscillator is voltage-dependent as shown in the “Electrical Characteristics” section.

When waking up from the Power-down mode, a delay from the wake-up condition occurs until the wake-up becomes effective. This allows the clock to restart and become stable after having been stopped. The wake-up period is defined by the same CKSEL Fuses that define the Reset Time-out period.

Tuneable Internal RC Oscillator

The internal RC Oscillator provides a fixed 1.6 MHz clock (nominal at 5V and 25°C). This internal clock is always the system clock of the ATtiny15L. This Oscillator can be calibrated by writing the calibration byte (see page 55) to the OSCCAL Register.

The System Clock Oscillator Calibration Register – OSCCAL

Bit	7	6	5	4	3	2	1	0	
\$31	CAL7	CAL6	CAL5	CAL4	CAL3	CAL2	CAL1	CAL0	OSCCAL
Read/Write	R/W	R/W	R/W	R/W	R/W	R/W	R/W	R/W	
Initial Value	0	0	0	0	0	0	0	0	

Writing the calibration byte to this address will trim the internal Oscillator frequency in order to remove process variations. When OSCCAL is zero (initial value), the lowest available frequency is chosen. Writing non-zero values to this register will increase the frequency of the internal oscillator. Writing \$FF to the register selects the highest available frequency.

Internal PLL for Fast Peripheral Clock Generation

The internal PLL in ATtiny15L generates a clock frequency that is 16x multiplied from the RC Oscillator system clock. If the RC Oscillator frequency is the nominal 1.6 MHz, the fast peripheral clock is 25.6 MHz. The fast peripheral clock, or a clock prescaled from that, can be selected as the clock source for Timer/Counter1.

The PLL is locked on the tuneable internal RC Oscillator and adjusting the tuneable internal RC oscillator via the OSCCAL Register will adjust the fast peripheral clock at the same time. Timer1 may malfunction if the internal RC oscillator is adjusted beyond 1.75 MHz.

It is recommended not to take the OSCCAL adjustments to a higher frequency than 1.75 MHz in order to keep proper operation of all chip functions.

Timer/Counters

The ATtiny15L provides two general purpose 8-bit Timer/Counters. The Timer/Counters have separate prescaling selection from separate 10-bit prescalers. The Timer/Counter0 uses internal clock (CK) as the clock time base. The Timer/Counter1 may use either the internal clock (CK) or the fast peripheral clock (PCK) as the clock time base.

The Timer/Counter0 Prescaler

Figure 18 shows the Timer/Counter prescaler.

Figure 18. Timer/Counter0 Prescaler

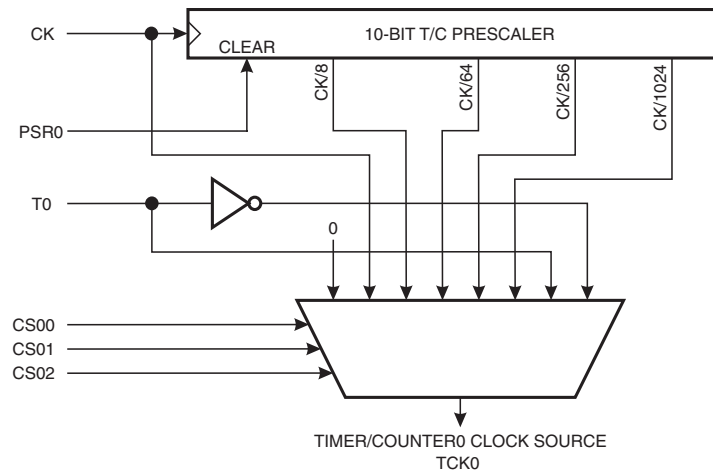

The four prescaled selections are: CK/8, CK/64, CK/256, and CK/1024, where CK is the Oscillator clock. CK, external source and stop, can also be selected as clock sources. Setting the PSR10 bit in SFIOR resets the prescaler. This allows the user to operate with a predictable prescaler.

The Timer/Counter1 Prescaler

Figure 19 shows the Timer/Counter1 prescaler. For Timer/Counter1 the clock selections are: PCK, PCK/2, PCK/4, PCK/8, CK (=PCK/16), CK/2, CK/4, CK/8, CK/16, CK/32, CK/64, CK/128, CK/256, CK/512, CK/1024, and stop. The clock options are described in Table 12 on page 31 and the Timer/Counter1 Control Register (TCCR1). Setting the PSR1 bit in the SFIOR Register resets the 10-bit prescaler. This allows the user to operate with a predictable prescaler.

Figure 19. Timer/Counter1 Prescaler

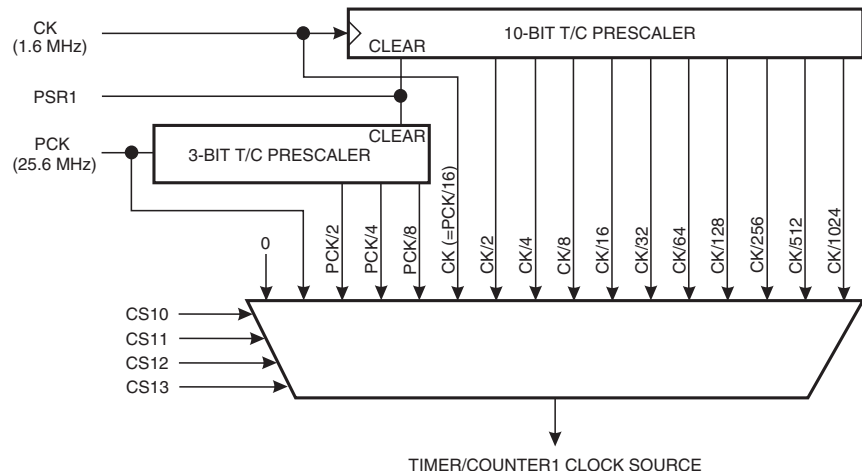

The Special Function IO Register – SFIOR

Bit	7	6	5	4	3	2	1	0	
\$2C	–	–	–	–	–	FOC1A	PSR1	PSR0	SFIOR
Read/Write	R	R	R	R	R	R/W	R/W	R/W	
Initial Value	0	0	0	0	0	0	0	0	

- **Bit 7..3 – Res: Reserved Bits**

These bits are reserved bits in the ATtiny15L and always read as zero.

- **Bit 2 – FOC1A: Force Output Compare 1A**

Writing a logical “1” to this bit forces a change in the Compare Match Output pin PB1 (OC1A) according to the values already set in COM1A1 and COM1A0. The Force Output Compare bit can be used to change the output pin without waiting for a compare match in timer. The automatic action programmed in COM1A1 and COM1A0 happens as if a Compare Match had occurred, but no interrupt is generated and the Timer/Counter1 will not be cleared even if CTC1 is set. The FOC1A bit will always be read as zero. The setting of the FOC1A bit has no effect in PWM mode.

- **Bit 1 – PSR1: Prescaler Reset Timer/Counter1**

When this bit is set (one) the Timer/Counter1 prescaler will be reset. The bit will be cleared by hardware after the operation is performed. Writing a “0” to this bit will have no effect. This bit will always be read as zero.

- **Bit 0 – PSR0: Prescaler Reset Timer/Counter0**

When this bit is set (one) the Timer/Counter0 prescaler will be reset. The bit will be cleared by hardware after the operation is performed. Writing a “0” to this bit will have no effect. This bit will always be read as zero.

The 8-bit Timer/Counter0

Figure 20 shows the block diagram for Timer/Counter0.

The 8-bit Timer/Counter0 can select clock source from CK, prescaled CK or an external pin. In addition, it can be stopped as described in the specification for the Timer/Counter0 Control Register (TCCR0). The Overflow Status Flag is found in the Timer/Counter Interrupt Flag Register (TIFR). Control signals are found in the Timer/Counter0 Control Register (TCCR0). The interrupt enable/disable settings for Timer/Counter0 are found in the Timer/Counter Interrupt Mask Register (TIMSK).

When Timer/Counter0 is externally clocked, the external signal is synchronized with the oscillator frequency of the CPU. To ensure proper sampling of the external clock, the minimum time between two external clock transitions must be at least one internal CPU clock period. The external clock signal is sampled on the rising edge of the internal CPU clock.

The 8-bit Timer/Counter0 features both a high-resolution and a high-accuracy usage with the lower prescaling opportunities. Similarly, the high-prescaling opportunities make the Timer/Counter0 useful for lower-speed functions or exact-timing functions with infrequent actions.

Figure 20. Timer/Counter0 Block Diagram

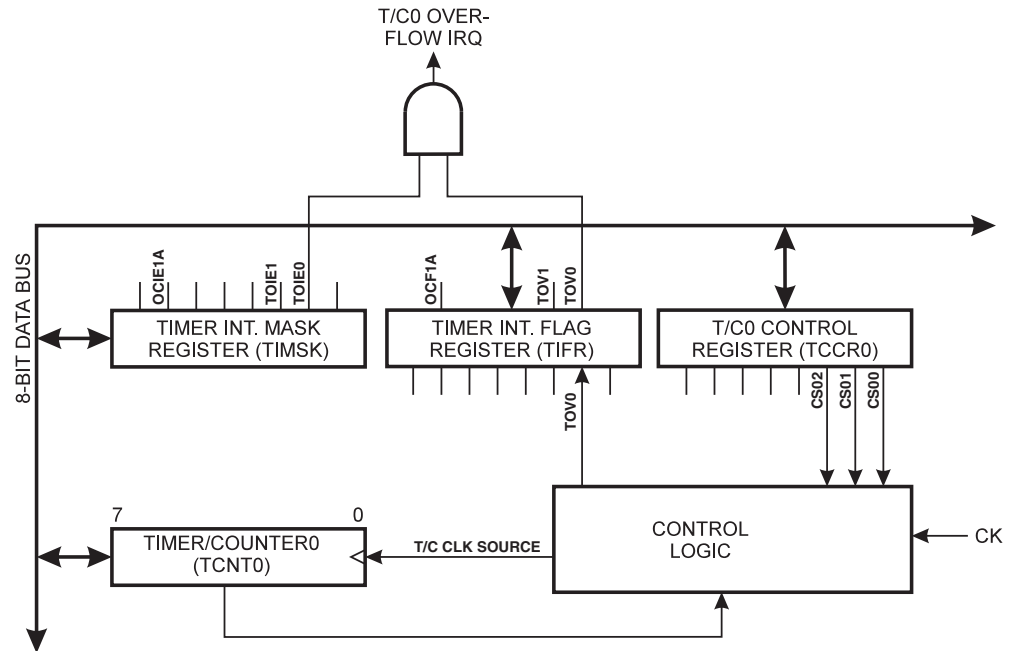

The Timer/Counter0 Control Register – TCCR0

Bit	7	6	5	4	3	2	1	0	
\$33	-	-	-	-	-	CS02	CS01	CS00	TCCR0
Read/Write	R	R	R	R	R	R/W	R/W	R/W	
Initial Value	0	0	0	0	0	0	0	0	

- **Bits 7..3 – Res: Reserved Bits**

These bits are reserved bits in the ATtiny15L and always read as zero.

- **Bits 2, 1, 0 – CS02, CS01, CS00: Clock Select0, Bits 2, 1 and 0**

The Clock Select0 bits 2, 1 and 0 define the prescaling source of Timer0.

Table 9. Clock 0 Prescale Select

CS02	CS01	CS00	Description
0	0	0	Stop, the Timer/Counter0 is stopped.
0	0	1	CK
0	1	0	CK/8
0	1	1	CK/64
1	0	0	CK/256
1	0	1	CK/1024
1	1	0	External Pin T0, falling edge
1	1	1	External Pin T0, rising edge

The Stop condition provides a Timer Enable/Disable function. The prescaled CK modes are scaled directly from the CK Oscillator clock. If the external pin modes are used for Timer/Counter0, transitions on PB2/(T0) will clock the counter even if the pin is configured as an output. This feature can give the user SW control of counting.

The Timer Counter 0 – TCNT0

Bit	7	6	5	4	3	2	1	0	
\$32	MSB							LSB	TCNT0
Read/Write	R/W	R/W	R/W	R/W	R/W	R/W	R/W	R/W	
Initial Value	0	0	0	0	0	0	0	0	

The Timer/Counter0 is implemented as an up-counter with read and write access. If the Timer/Counter0 is written and a clock source is present, the Timer/Counter0 continues counting in the timer clock cycle following the write operation.

The 8-bit Timer/Counter1

This module features a high-resolution and a high-accuracy usage with the lower prescaling opportunities. Timer/Counter1 can also be used as an accurate, high speed, 8-bit Pulse Width Modulator (PWM) using clock speeds up to 25.6 MHz. In this mode, Timer/Counter1 and the Output Compare Registers serve as a standalone PWM. Refer to page 34 for a detailed description of this function. Similarly, the high-prescaling opportunities make this unit useful for lower-speed functions or exact-timing functions with infrequent actions.

Figure 21 shows the block diagram for Timer/Counter1.

Figure 21. Timer/Counter1 Block Diagram

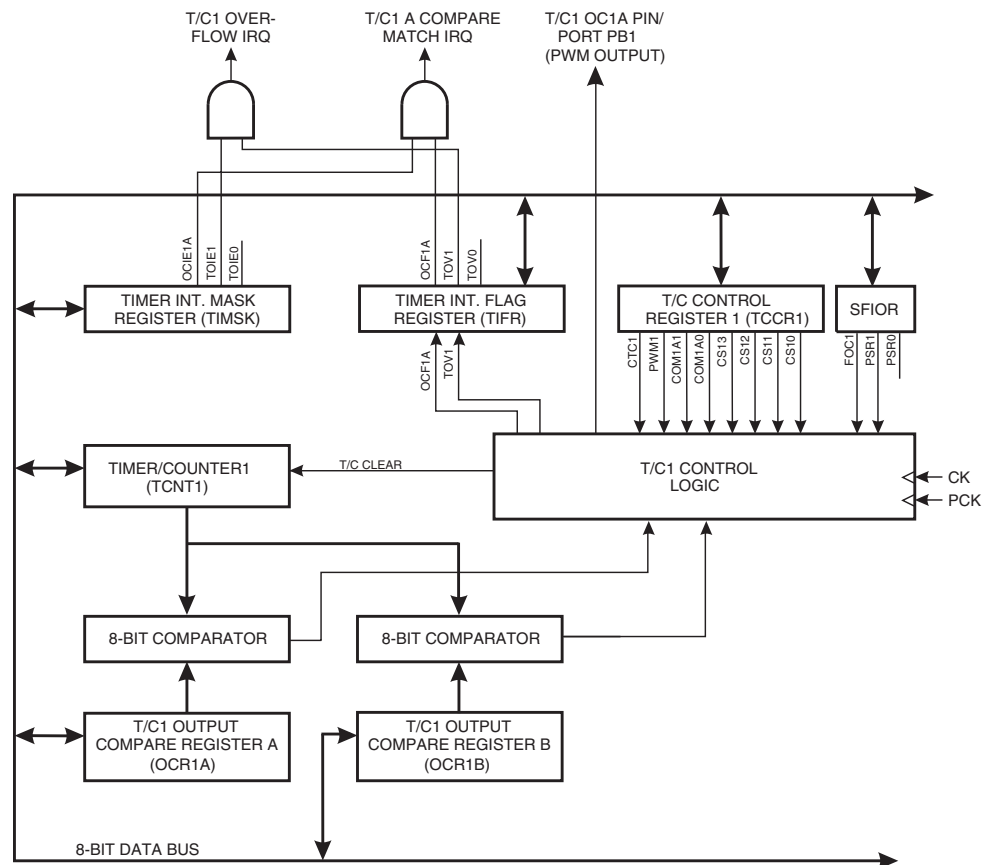

The two Status Flags (Overflow and Compare Match) are found in the Timer/Counter Interrupt Flag Register (TIFR). Control signals are found in the Timer/Counter Control Register (TCCR1). The interrupt enable/disable settings are found in the Timer/Counter Interrupt Mask Register (TIMSK).

The Timer/Counter1 contains two Output Compare Registers, OCR1A and OCR1B, as the data source to be compared with the Timer/Counter1 contents. In Normal mode the Output Compare function is operational with OCR1A only, and the Output Compare function includes optional clearing of the counter on compare match, and action on the Output Compare pin (PB1) (OC1A).

In PWM mode OCR1A provides the data value against which the Timer/Counter value is compared. Upon compare match the PWM output is generated. In PWM mode The Timer/Counter counts up to the value specified in Output Compare Register OCR1B and starts again from \$00. This feature allows limiting the counter “full” value to a specified value, lower than \$FF. However, if OCR1n is \$00, the output will remain constant and not toggle at all. If OCR1n equals \$01, the pulse width will be two ticks, increasing linearly if OCR1n is larger than \$01. Together with the many prescaler options, flexible PWM frequency selection is provided. Table 14 lists clock selection and OCR1B values to obtain PWM frequencies from 10 kHz to 150 kHz at 10 kHz steps.

In applications with variable PWM, halving the prescaler setting and doubling the duty cycle can be used to fine-tune the PWM. Alternatively inverted PWM can be used.

The Timer/Counter1 Control Register – TCCR1

Bit	7	6	5	4	3	2	1	0	
\$30	TCCR1								TCCR1
Read/Write	R/W	R/W	R/W	R/W	R/W	R/W	R/W	R/W	
Initial Value	0	0	0	0	0	0	0	0	

- **Bit 7 – CTC1: Clear Timer/Counter on Compare Match**

When the CTC1 control bit is set (one), Timer/Counter1 is reset to \$00 in the CPU clock cycle after a compare match with OCR1A Register value. If the control bit is cleared, Timer/Counter1 continues counting and is unaffected by a compare match.

- **Bit 6 – PWM1: Pulse Width Modulator Enable**

When set (one), this bit enables PWM mode for Timer/Counter1. This mode is described on page 31.

- **Bits 5,4 – COM1A1, COM1A0: Compare Output Mode, Bits 1 and 0**

The COM1A1 and COM1A0 control bits determine any output pin action following a compare match A in Timer/Counter1. Output pin actions affect pin PB1(OC1A). Since this is an alternative function to an I/O port, the corresponding direction control bit must be set (one) to control an output pin. The control configuration is shown in Table 10.

Table 10. Compare Mode Select⁽¹⁾

COM1A1	COM1A0	Description
0	0	Timer/Counter disconnected from output pin OC1A
0	1	Toggle the OC1A output line.
1	0	Clear the OC1A output line (to zero).
1	1	Set the OC1A output line (to one).

Note: 1. In PWM mode, these bits have a different function. Refer to Table 12 for a detailed description. When changing the COM1A1/COM1A0 bits, the Output Compare 1A Interrupt must be disabled by clearing its Interrupt Enable bit in the TIMSK Register. Otherwise an interrupt can occur when the bits are changed.

• **Bits 3, 2, 1, 0 – CS13, CS12, CS11, CS10: Clock Select Bits 3, 2, 1, and 0**

The Clock Select bits 3, 2, 1, and 0 define the prescaling source of Timer/Counter1.

Table 11. Timer/Counter1 Prescale Select

CS13	CS12	CS11	CS10	Description
0	0	0	0	Timer/Counter1 is stopped.
0	0	0	1	CK*16 (=PCK)
0	0	1	0	CK*8 (=PCK/2)
0	0	1	1	CK*4 (=PCK/4)
0	1	0	0	CK*2 (=PCK/8)
0	1	0	1	CK
0	1	1	0	CK/2
0	1	1	1	CK/4
1	0	0	0	CK/8
1	0	0	1	CK/16
1	0	1	0	CK/32
1	0	1	1	CK/64
1	1	0	0	CK/128
1	1	0	1	CK/256
1	1	1	0	CK/512
1	1	1	1	CK/1024

The Stop condition provides a Timer Enable/Disable function. The prescaled CK modes are scaled directly from the CK oscillator clock.

The Timer/Counter1 – TCNT1

Bit	7	6	5	4	3	2	1	0	
\$2F	MSB							LSB	TCNT1
Read/Write	R/W	R/W	R/W	R/W	R/W	R/W	R/W	R/W	
Initial Value	0	0	0	0	0	0	0	0	

This 8-bit register contains the value of Timer/Counter1.

Timer/Counter1 is implemented as an up-counter with read and write access. Due to synchronization of the CPU and Timer/Counter1, data written into Timer/Counter1 is delayed by one CPU clock cycle.

Timer/Counter1 Output Compare RegisterA – OCR1A

Bit	7	6	5	4	3	2	1	0	
\$2E									OCR1A
Read/Write	R/W	R/W	R/W	R/W	R/W	R/W	R/W	R/W	
Initial Value	0	0	0	0	0	0	0	0	

The Output Compare Register 1A is an 8-bit read/write register.

The Timer/Counter Output Compare Register 1A contains the data to be continuously compared with Timer/Counter1. Actions on compare matches are specified in TCCR1. A compare match occurs only if Timer/Counter1 counts to the OCR1A value. A software write that sets TCNT1 and OCR1A to the same value does not generate a compare match.

A compare match will set (one) the Compare Interrupt Flag in the CPU clock cycle following the compare event.

Timer/Counter1 in PWM Mode

When the PWM mode is selected, Timer/Counter1 and the Output Compare Register A (OCR1A) form an 8-bit, free-running and glitch-free PWM with outputs on the PB1(OC1A) pin. Timer/Counter1 acts as an up-counter, counting up from \$00 up to the value specified in the second Output Compare Register OCR1B, and starting from \$00 up again. When the counter value matches the contents of the Output Compare Register OCR1A, the PB1(OC1A) pin is set or cleared according to the settings of the COM1A1/COM1A0 bits in the Timer/Counter1 Control Registers TCCR1. Refer to Table 12 for details.

Table 12. Compare Mode Select in PWM Mode

COM1A1	COM1A0	Effect on Compare Pin
0	0	Not connected
0	1	Not connected
1	0	Cleared on compare match (up-counting) (non-inverted PWM). Set when TCNT1 = \$00.
1	1	Set on compare match (up-counting) (inverted PWM). Cleared when TCNT1 = \$00.

Note that in PWM mode, writing to the Output Compare OCR1A, the data value is first transferred to a temporary location. The value is latched into OCR1A when the Timer/Counter reaches OCR1B. This prevents the occurrence of odd-length PWM pulses (glitches) in the event of an unsynchronized OCR1A write. See Figure 22 for an example.

Figure 22. Effects of Unsynchronized OCR Latching

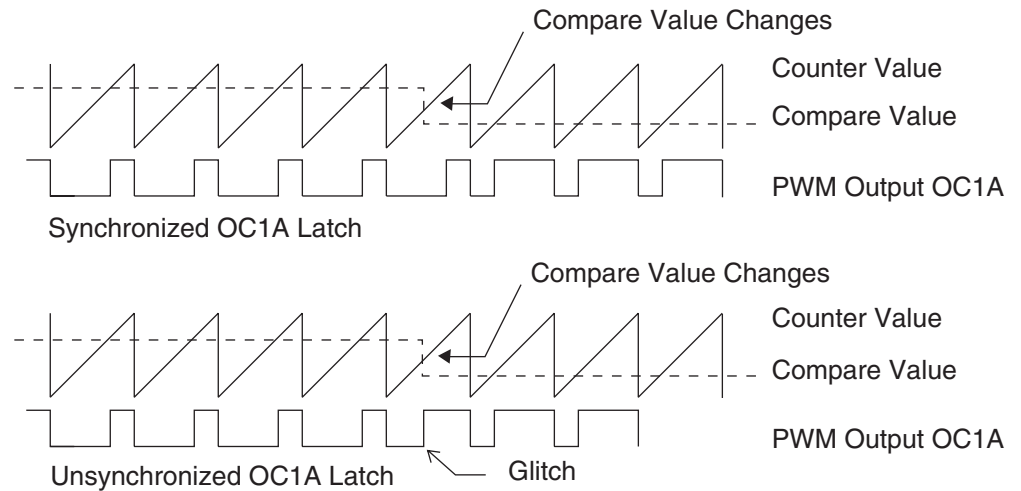

During the time between the write and the latch operation, a read from OCR1A will read the contents of the temporary location. This means that the most recently written value always will read out of OCR1A.

When OCR1A contains \$00 or the top value, as specified in OCR1B Register, the output PB1(OC1A) is held low or high according to the settings of COM1A1/COM1A0. This is shown in Table 13.

Timer/Counter1 Output Compare RegisterB – OCR1B

Bit	7	6	5	4	3	2	1	0	
\$2D	MSB							LSB	OCR1B
Read/Write	R/W	R/W	R/W	R/W	R/W	R/W	R/W	R/W	
Initial Value	1	1	1	1	1	1	1	1	

The Output Compare Register1 (OCR1B) is an 8-bit read/write register. This register is used in the PWM mode only, and it limits the top value to which the Timer/Counter1 keeps counting. After reaching OCR1B in PWM mode, the counter starts from \$00.

Table 13. PWM Outputs when OCR1A = \$00 or OCR1B

COM1A1	COM1A0	OCR1B	Output PWMn
1	0	\$00	L
1	0	OCR1B	H
1	1	\$00	H
1	1	OCR1B	L

In PWM mode, the Timer Overflow Flag (TOV1) is set as in normal Timer/Counter mode. Timer Overflow Interrupt1 operates exactly as in normal Timer/Counter mode, i.e., it is executed when TOV1 is set provided that Timer Overflow Interrupt and global interrupts are enabled. This also applies to the Timer Output Compare A Flag and interrupt.

The frequency of the PWM will be Timer Clock Frequency divided by OCR1B value + 1.

Table 14. Timer/Counter1 Clock Prescale Select

Clock Selection	OCR1B	PWM Frequency
CK	159	10 kHz
PCK/8	159	20 kHz
PCK/4	213	30 kHz
PCK/4	159	40 kHz
PCK/2	255	50 kHz
PCK/2	213	60 kHz
PCK/2	181	70 kHz
PCK/2	159	80 kHz
PCK/2	141	90 kHz
PCK	255	100 kHz
PCK	231	110 kHz
PCK	213	120 kHz
PCK	195	130 kHz
PCK	181	140 kHz
PCK	169	150 kHz

The exact duty-cycle of the non-inverted PWM output is:

$$\frac{(OCR1A + 1) \times T_{T1} - T_{PCK}}{(OCR1B + 1) \times T_{T1}}$$

Where:

T_{T1} is the period of the selected Timer/Counter1 Clock Source.

T_{PCK} is the period of the PCK Clock (39.1 ns).

The Watchdog Timer

The Watchdog Timer is clocked from a separate On-chip Oscillator that runs at 1 MHz. This is the typical value at $V_{CC} = 5V$. See “Typical Characteristics” on page 66 for typical values at other V_{CC} levels. By controlling the Watchdog Timer prescaler, the Watchdog Reset interval can be adjusted from 16 to 2,048 ms, as shown in Table 15. The WDR (Watchdog Reset) instruction resets the Watchdog Timer. Eight different clock cycle periods can be selected to determine the reset period. If the reset period expires without another Watchdog Reset, the ATtiny15L resets and executes from the Reset Vector. For timing details on the Watchdog Reset, refer to page 17.

To prevent unintentional disabling of the Watchdog, a special turn-off sequence must be followed when the Watchdog is disabled. Refer to the description of the Watchdog Timer Control Register for details.

Figure 23. Watchdog Timer

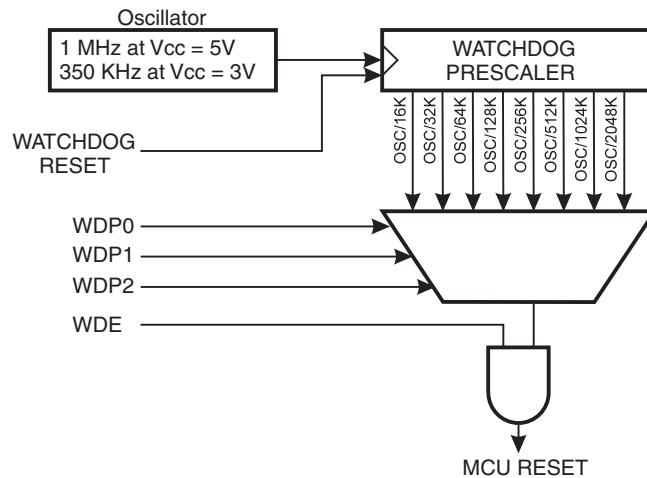

The Watchdog Timer Control Register – WDTCR

Bit	7	6	5	4	3	2	1	0	
\$21	–	–	–	WDTOE	WDE	WDP2	WDP1	WDP0	WDTCR
Read/Write	R	R	R	R/W	R/W	R/W	R/W	R/W	
Initial Value	0	0	0	0	0	0	0	0	

- **Bits 7..5 – Res: Reserved Bits**

These bits are reserved bits in the ATtiny15L and will always read as zero.

- **Bit 4 – WDTOE: Watchdog Turn-off Enable**

This bit must be set (one) when the WDE bit is cleared. Otherwise, the Watchdog will not be disabled. Once set, hardware will clear this bit to zero after four clock cycles. Refer to the description of the WDE bit for a Watchdog disable procedure.

- **Bit 3 – WDE: Watchdog Enable**

When the WDE is set (one), the Watchdog Timer is enabled and if the WDE is cleared (zero), the Watchdog Timer function is disabled. WDE can be cleared only when the WDTOE bit is set (one). To disable an enabled Watchdog Timer, the following procedure must be followed:

1. In the same operation, write a logical “1” to WDTOE and WDE. A logical “1” must be written to WDE even though it is set to one before the disable operation starts.
2. Within the next four clock cycles, write a logical “0” to WDE. This disables the Watchdog.

• **Bits 2..0 – WDP2, WDP1, WDP0: Watchdog Timer Prescaler Bits 2, 1, and 0**

The WDP2, WDP1 and WDP0 bits determine the Watchdog Timer prescaling when the Watchdog Timer is enabled. The different prescaling values and their corresponding time-out periods are shown in Table 15.

Table 15. Watchdog Timer Prescale Select

WDP2	WDP1	WDP0	Time-out Period
0	0	0	16K cycles
0	0	1	32K cycles
0	1	0	64K cycles
0	1	1	128K cycles
1	0	0	256K cycles
1	0	1	512K cycles
1	1	0	1,024K cycles
1	1	1	2,048K cycles

EEPROM Read/Write Access

The EEPROM Access Registers are accessible in the I/O space.

The write access time is in the range of 4.6 - 8.2 ms, depending on the frequency of the calibrated RC Oscillator. See Table 16 for details. A self-timing function however, lets the user software detect when the next byte can be written. If the user code contains code that writes the EEPROM, some precautions must be taken. In heavily filtered power supplies, V_{CC} is likely to rise or fall slowly on Power-up/down. This causes the device for some period of time to run at a voltage lower than specified as minimum for the clock frequency used. CPU operation under these conditions is likely to cause the Program Counter to perform unintentional jumps and eventually execute the EEPROM write code. To secure EEPROM integrity, the user is advised to use an external under-voltage reset circuit in this case.

In order to prevent unintentional EEPROM writes, a two-state write procedure must be followed. Refer to the description of the EEPROM Control Register for details of this.

When the EEPROM is read or written, the CPU is halted for two clock cycles before the next instruction is executed.

The EEPROM Address Register – EEAR

Bit	7	6	5	4	3	2	1	0	
\$1E	–	–	EEAR5	EEAR4	EEAR3	EEAR2	EEAR1	EEAR0	EEAR
Read/Write	R	R	R/W	R/W	R/W	R/W	R/W	R/W	
Initial Value	0	0	X	X	X	X	X	X	

- **Bit 7, 6 – Res: Reserved Bits**

These bits are reserved bits in the ATtiny15L and will always read as zero.

- **Bit 5..0 – EEAR5..0: EEPROM Address**

The EEPROM Address Register (EEAR) specifies the EEPROM address in the 64 bytes EEPROM space. The EEPROM data bytes are addresses linearly between 0 and 63. The initial value of EEAR is undefined. A proper value must be written before the EEPROM may be accessed.

The EEPROM Data Register – EEDR

Bit	7	6	5	4	3	2	1	0	
\$1D	MSB							LSB	EEDR
Read/Write	R/W	R/W	R/W	R/W	R/W	R/W	R/W	R/W	
Initial Value	0	0	0	0	0	0	0	0	

- **Bit 7..0 – EEDR7..0: EEPROM Data**

For the EEPROM write operation, the EEDR Register contains the data to be written to the EEPROM in the address given by the EEAR Register. For the EEPROM read operation, the EEDR contains the data read out from the EEPROM at the address given by EEAR.

The EEPROM Control Register – EECR

Bit	7	6	5	4	3	2	1	0	
\$1C	–	–	–	–	EERIE	EEMWE	EEWE	EERE	EECR
Read/Write	R	R	R	R	R/W	R/W	R/W	R/W	
Initial value	0	0	0	0	0	0	X	0	

- **Bit 7..4 – RES: Reserved Bits**

These bits are reserved bits in the ATtiny15L and will always read as zero.

- **Bit 3 – EERIE: EEPROM Ready Interrupt Enable**

When the I-bits in SREG and EERIE are set (one), the EEPROM Ready Interrupt is enabled. When cleared (zero), the interrupt is disabled. The EEPROM Ready Interrupt generates a constant interrupt when EEWE is cleared (zero).

- **Bit 2 – EEMWE: EEPROM Master Write Enable**

The EEMWE bit determines whether setting EEWE to one causes the EEPROM to be written. When EEMWE is set (one), setting EEWE will write data to the EEPROM at the selected address. If EEMWE is zero, setting EEWE will have no effect. When EEMWE has been set (one) by software, hardware clears the bit to zero after four clock cycles. See the description of the EEWE bit for an EEPROM write procedure.

- **Bit 1 – EEWE: EEPROM Write Enable**

The EEPROM Write Enable Signal – EEWE – is the write strobe to the EEPROM. When address and data are correctly set up, the EEWE bit must be set to write the value in to the EEPROM. The EEMWE bit must be set when the logical “1” is written to EEWE, otherwise no EEPROM write takes place. The following procedure should be followed when writing the EEPROM (the order of steps 2 and 3 is not essential):

1. Wait until EEWE becomes zero.
2. Write new EEPROM address to EEAR (optional).
3. Write new EEPROM data to EEDR (optional).
4. Write a logical “1” to the EEMWE bit in EECR.
5. Within four clock cycles after setting EEMWE, write a logical “1” to EEWE.

Caution: An interrupt between step 4 and step 5 will make the write cycle fail, since the EEPROM Master Write Enable will time-out. If an interrupt routine accessing the EEPROM is interrupting another EEPROM access, the EEAR or EEDR Register will be modified, causing the interrupted EEPROM access to fail. It is recommended to have the Global Interrupt Flag cleared during the four last steps to avoid these problems.

When the write access time (typically 5.1 ms if the internal RC Oscillator is calibrated to 1.6 MHz) has elapsed, the EEWE bit is cleared (zero) by hardware. The user software can poll this bit and wait for a zero before writing the next byte. When EEWE has been set, the CPU is halted for two cycles before the next instruction is executed.

- **Bit 0 – EERE: EEPROM Read Enable**

The EEPROM Read Enable Signal EERE is the read strobe to the EEPROM. When the correct address is set up in the EEAR Register, the EERE bit must be set. When the EERE bit is cleared (zero) by hardware, requested data is found in the EEDR Register. The EEPROM read access takes one instruction and there is no need to poll the EERE bit. When EERE has been set, the CPU is halted for four cycles before the next instruction is executed.



The user should poll the EEWB bit before starting the read operation. If a write operation is in progress when new data or address is written to the EEPROM I/O Registers, the write operation will be interrupted and the result is undefined.

The calibrated oscillator is used to time EEPROM. In Table 16 the typical programming time is listed for EEPROM access from the CPU.

Table 16. Typical EEPROM Programming Times

Parameter	Number of Calibrated RC Oscillator Cycles	Min Programming Time	Max Programming Time
EEPROM write (from CPU)	8192	4.6 ms	8.2 ms

Preventing EEPROM Corruption

During periods of low V_{CC} , the EEPROM data can be corrupted because the supply voltage is too low for the CPU and the EEPROM to operate properly. These issues are the same as for board-level systems using the EEPROM and the same design solutions should be applied.

An EEPROM data corruption can be caused by two situations when the voltage is too low. First, a regular write sequence to the EEPROM requires a minimum voltage to operate correctly. Second, the CPU itself can execute instructions incorrectly if the supply voltage for executing instructions is too low.

EEPROM data corruption can easily be avoided by following these design recommendations (one is sufficient):

1. Keep the AVR RESET active (low) during periods of insufficient power supply voltage. This can be done by enabling the internal Brown-out Detector (BOD) if the operating voltage matches the detection level. If not, an external low V_{CC} Reset Protection circuit can be applied.
2. Keep the AVR core in Power-down sleep mode during periods of low V_{CC} . This will prevent the CPU from attempting to decode and execute instructions, effectively protecting the EEPROM Registers from unintentional writes.
3. Store constants in Flash memory if the ability to change memory contents from software is not required. Flash memory cannot be updated by the CPU and will not be subject to corruption.

The Analog Comparator

The Analog Comparator compares the input values on the positive pin PB0 (AIN0) and negative pin PB1 (AIN1). When the voltage on the positive pin PB0 (AIN0) is higher than the voltage on the negative pin PB1 (AIN1), the Analog Comparator Output (ACO) is set (one). The comparator's output can trigger a separate interrupt, exclusive to the Analog Comparator. The user can select interrupt triggering on comparator output rise, fall or toggle. A block diagram of the Comparator and its surrounding logic is shown in Figure 24.

Figure 24. Analog Comparator Block Diagram

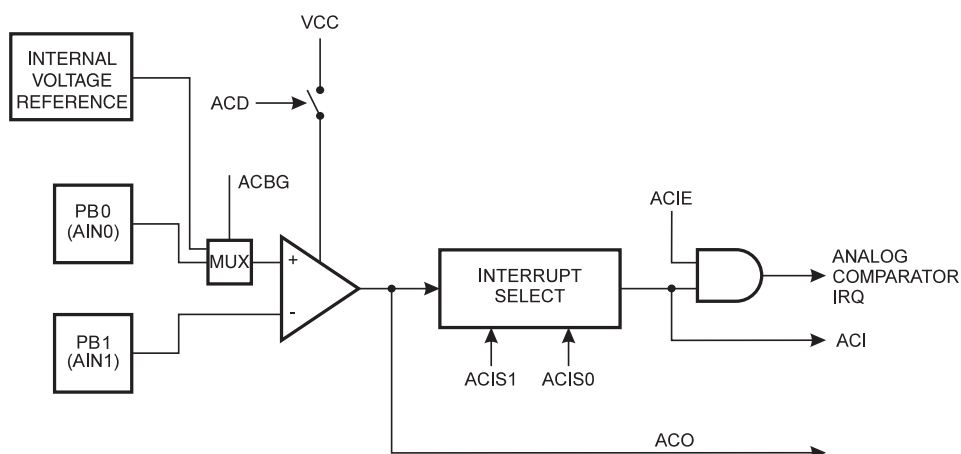

The Analog Comparator Control and Status Register – ACSR

Bit	7	6	5	4	3	2	1	0	
\$08	ACD	ACBG	ACO	ACI	ACIE	–	ACIS1	ACIS0	ACSR
Read/Write	R/W	R/W	R	R/W	R/W	R	R/W	R/W	
Initial Value	0	0	X	0	0	0	0	0	

- **Bit 7 – ACD: Analog Comparator Disable**

When this bit is set (one), the power to the Analog Comparator is switched off. This bit can be set at any time to turn off the Analog Comparator. This will reduce power consumption in Active and Idle mode. When changing the ACD-bit, the Analog Comparator Interrupt must be disabled by clearing the ACIE bit in ACSR. Otherwise an interrupt can occur when the bit is changed.

- **Bit 6 – ACBG: Analog Comparator Bandgap Select**

When this bit is set, a fixed bandgap voltage of $1.22 \pm 0.05V$ replaces the normal input to the positive pin (AIN0) of the comparator. When this bit is cleared, the normal input pin PB0 is applied to the positive pin of the comparator.

- **Bit 5 – ACO: Analog Comparator Output**

ACO is directly connected to the comparator output.

- **Bit 4 – ACI: Analog Comparator Interrupt Flag**

This bit is set (one) when a comparator output event triggers the interrupt mode defined by ACI1 and ACI0. The Analog Comparator Interrupt routine is executed if the ACIE bit is set (one) and the I-bit in SREG is set (one). ACI is cleared by hardware when executing the corresponding interrupt handling vector. Alternatively, ACI is cleared by writing a logical "1" to the flag.

- **Bit 3 – ACIE: Analog Comparator Interrupt Enable**

When the ACIE bit is set (one) and the I-bit in the Status Register is set (one), the Analog Comparator Interrupt is activated. When cleared (zero), the interrupt is disabled.

- **Bit 2 – Res: Reserved Bit**

This bit is a reserved bit in the ATtiny15L and will always read as zero.

- **Bits 1, 0 – ACIS1, ACIS0: Analog Comparator Interrupt Mode Select**

These bits determine the comparator events that trigger the Analog Comparator Interrupt. The different settings are shown in Table 17.

Table 17. ACIS1/ACIS0 Settings⁽¹⁾

ACIS1	ACIS0	Interrupt Mode
0	0	Comparator Interrupt on Output Toggle
0	1	Reserved
1	0	Comparator Interrupt on Falling Output Edge
1	1	Comparator Interrupt on Rising Output Edge

Note: 1. When changing the ACIS1/ACIS0 bits, The Analog Comparator Interrupt must be disabled by clearing its Interrupt Enable bit in the ACSR Register. Otherwise an interrupt can occur when the bits are changed.

The Analog-to-Digital Converter, Analog Multiplexer, and Gain Stages

Features

- 10-bit Resolution
- ± 2 LSB Absolute Accuracy
- 0.5 LSB Integral Non-linearity
- Optional Offset Cancellation
- 65 - 260 μ s Conversion Time
- Up to 15 kSPS
- 4 Multiplexed Single-ended Input Channels
- 1 Differential Input Channel with Optional Gain of 20x
- 2.56V Internal Voltage Reference
- 0 - 2.56V Differential Input Voltage Range
- 0 - V_{CC} Single-ended Input Voltage Range
- Optional Left Adjustment for ADC Result Readout
- Free Running or Single Conversion Mode
- Interrupt on ADC Conversion Complete
- Sleep Mode Noise Canceler

The ATtiny15L features a 10-bit successive approximation ADC. The ADC is connected to a 4-channel Analog Multiplexer that allows one differential voltage input and four single-ended voltage inputs constructed from the pins of Port B. The differential input (PB3, PB4) is equipped with a programmable gain stage, providing amplification step of 26 dB (20x) on the differential input voltage before the A/D conversion. The single-ended voltage inputs at PB2..PB5 refer to 0V (GND).

The ADC contains a Sample and Hold Amplifier that ensures that the input voltage to the ADC is held at a constant level during conversion. A block diagram of the ADC is shown in Figure 25.

An internal reference voltage of nominally 2.56V is provided On-chip and this reference can optionally be externally decoupled at the AREF (PB0) pin by a capacitor for better noise performance. Alternatively, V_{CC} can be used as reference voltage for single-ended channels. There is also an option to use an external voltage reference and turn off the internal voltage reference. These options are selected using the REFS1..0 bits of the ADMUX Control Register.

Figure 25. Analog-to-Digital Converter Block Schematic

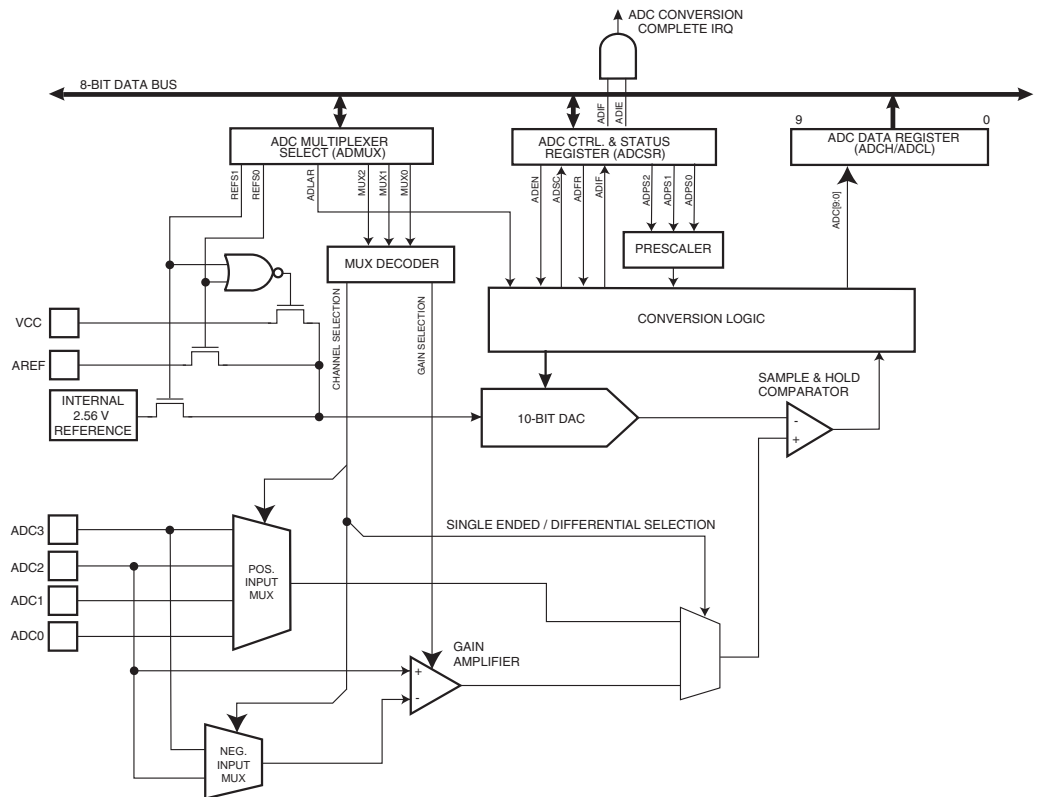

Operation

The ADC converts an analog input voltage to a 10-bit digital value through successive approximation. The minimum value represents GND and the maximum value represents the selected reference voltage minus 1 LSB.

The voltage reference for the ADC may be selected by writing to the REFS1..0 bits in ADMUX. V_{CC} , the AREF pin, or an internal 2.56V reference may be selected as the ADC voltage reference. Optionally, the 2.56V internal voltage reference may be decoupled by an external capacitor at the AREF pin to improve noise immunity.

The analog input channel and differential gain are selected by writing to the MUX2..0 bits in ADMUX. Any of the four ADC input pins ADC3..0 can be selected as single-ended inputs to the ADC. ADC2 and ADC3 can be selected as positive and negative input, respectively, to the differential gain amplifier.

If differential channels are selected, the differential gain stage amplifies the voltage difference between the selected input pair by the selected gain factor, 1x or 20x, according to the setting of the MUX2..0 bits in ADMUX. This amplified value then becomes the analog input to the ADC. If single-ended channels are used, the gain amplifier is bypassed altogether.

If ADC2 is selected as both the positive and negative input to the differential gain amplifier ($ADC2 - ADC2$), the remaining offset in the gain stage and conversion circuitry can be measured directly as the result of the conversion. This figure can be subtracted from subsequent conversions with the same gain setting to reduce offset error to below 1 LSB.

The ADC can operate in two modes – Single Conversion and Free Running. In Single Conversion mode, each conversion will have to be initiated by the user. In Free Running

mode, the ADC is constantly sampling and updating the ADC Data Register. The ADFR bit in ADCSR selects between the two available modes.

The ADC is enabled by setting the ADC Enable bit, ADEN in ADCSR. Voltage reference and input channel selections will not go into effect until ADEN is set. The ADC does not consume power when ADEN is cleared, so it is recommended to switch off the ADC before entering Power-saving sleep modes.

A conversion is started by writing a logical “1” to the ADC Start Conversion bit, ADSC. This bit stays high as long as the conversion is in progress and will be set to zero by hardware when the conversion is completed. If a different data channel is selected while a conversion is in progress, the ADC will finish the current conversion before performing the channel change.

The ADC generates a 10-bit result, which is presented in the ADC Data Registers, ADCH and ADCL. By default, the result is presented right-adjusted, but can optionally be presented left-adjusted by setting the ADLAR bit in ADMUX.

If the result is left-adjusted and no more than 8-bit precision is required, it is sufficient to read ADCH. Otherwise, ADCL must be read first, then ADCH, to ensure that the content of the Data Registers belongs to the same conversion. Once ADCL is read, ADC access to data registers is blocked. This means that if ADCL has been read, and a conversion completes before ADCH is read, neither register is updated and the result from the conversion is lost. When ADCH is read, ADC access to the ADCH and ADCL Registers is re-enabled.

The ADC has its own interrupt, which can be triggered when a conversion completes. When ADC access to the Data Registers is prohibited between reading of ADCH and ADCL, the interrupt will trigger even if the result is lost.

Prescaling and Conversion Timing

Figure 26. ADC Prescaler

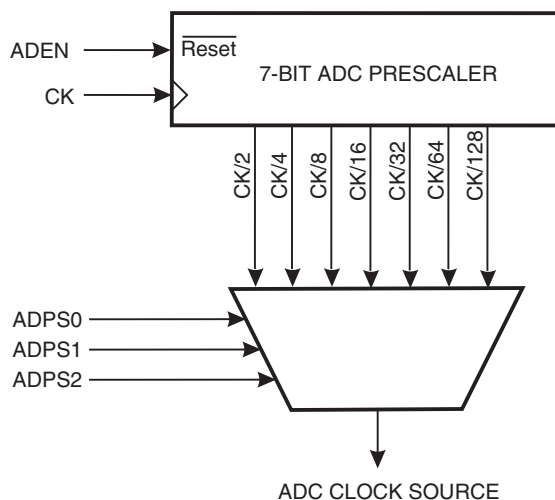

The successive approximation circuitry requires an input clock frequency between 50 kHz and 200 kHz. Using a higher input frequency will affect the conversion accuracy, see “ADC Characteristics” on page 50. The ADC module contains a prescaler, which divides the system clock to an acceptable ADC clock frequency.

The ADPSn bits in ADCSR are used to generate a proper ADC clock input frequency from any CK frequency above 100 kHz. The prescaler starts counting from the moment

the ADC is switched on by setting the ADEN bit in ADCSR. The prescaler keeps running for as long as the ADEN bit is set, and is continuously reset when ADEN is low.

When initiating a conversion by setting the ADSC bit in ADCSR, the conversion starts at the following rising edge of the ADC clock cycle. If differential channels are selected, the conversion will only start at every other rising edge of the ADC clock cycle after ADEN was set.

A normal conversion takes 13 ADC clock cycles. In certain situations, the ADC needs more clock cycles to perform initialization and minimize offset errors. These extended conversions take 25 ADC clock cycles and occur as the first conversion after one of the following events:

- The ADC is switched on (ADEN in ADCSR is set).
- The voltage reference source is changed (the REFS1..0 bits in ADMUX change value).
- A differential channel is selected (MUX2 in ADMUX is "1"). Note that subsequent conversions on the same channel are not extended conversions.

The actual sample-and-hold takes place 1.5 ADC clock cycles after the start of a normal conversion and 13.5 ADC clock cycles after the start of an extended conversion. When a conversion is complete, the result is written to the ADC Data Registers, and ADIF is set. In Single Conversion mode, ADSC is cleared simultaneously. The software may then set ADSC again, and a new conversion will be initiated on the first rising ADC clock edge. In Free Running mode, a new conversion will be started immediately after the conversion completes while ADSC remains high. Using Free Running mode and an ADC clock frequency of 200 kHz gives the lowest conversion time, 65 μ s, equivalent to 15 kSPS. For a summary of conversion times, see Table 18.

Figure 27. ADC Timing Diagram, First Conversion (Single Conversion Mode)

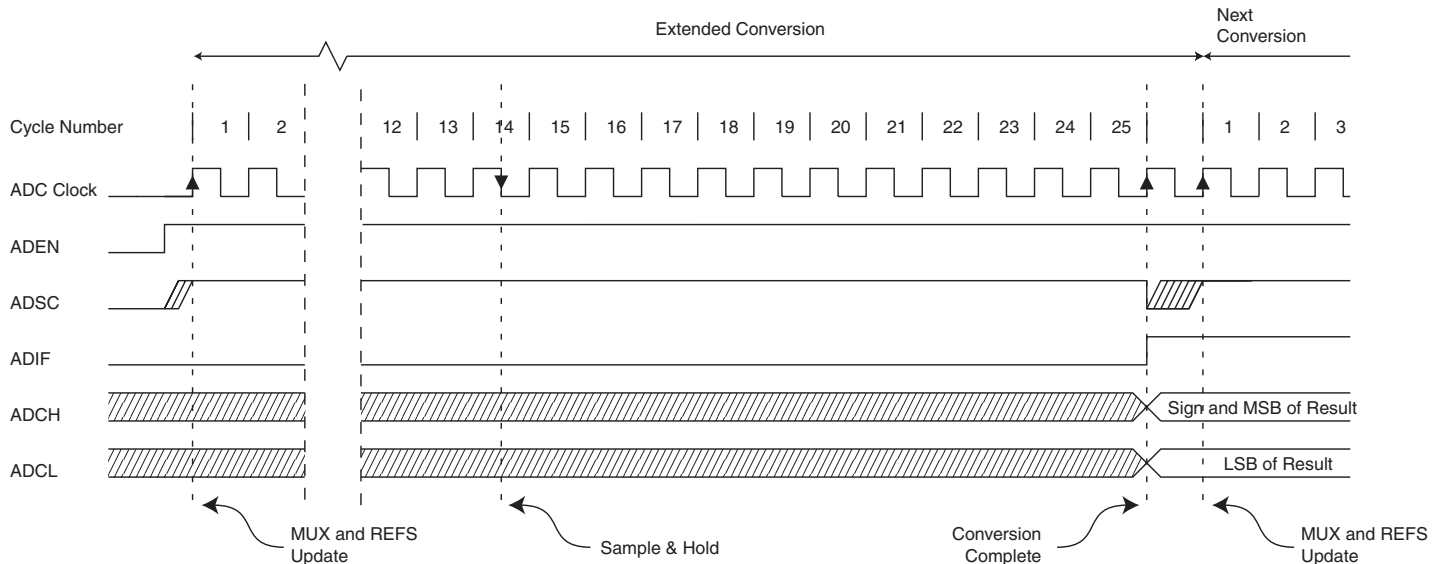

Figure 28. ADC Timing Diagram, Single Conversion

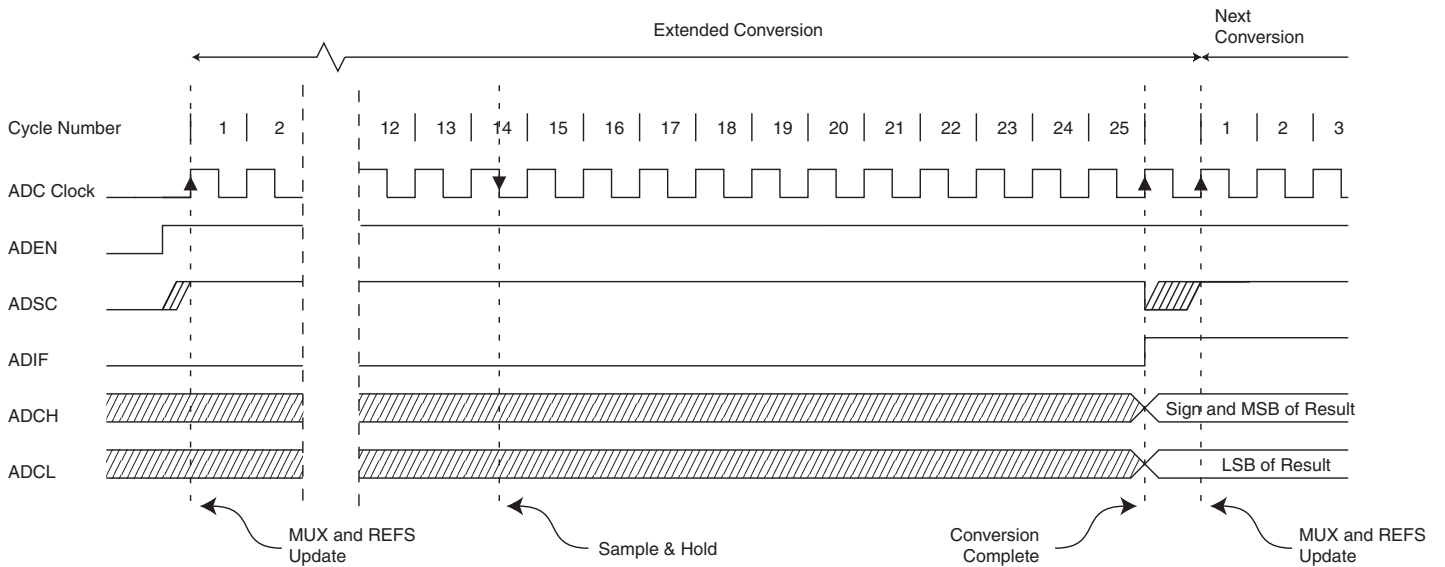

Figure 29. ADC Timing Diagram, Free Running Conversion

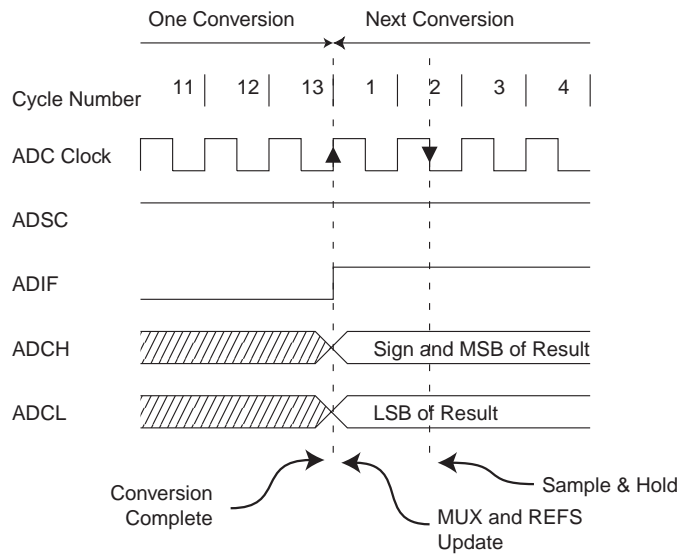

Table 18. ADC Conversion Time

Condition	Sample & Hold (Cycles from Start of Conversion)	Conversion Time (Cycles)	Conversion Time (μ s)
Extended Conversion	13.5	25.0	125 - 500
Normal Conversions	1.5	13.0	65 - 260

ADC Noise Canceler Function

The ADC features a noise canceler that enables conversion during ADC Noise Reduction mode (see “Sleep Modes” on page 23) to reduce noise induced from the CPU core and other I/O peripherals. If other I/O peripherals must be active during conversion, this mode works equivalently for Idle mode. To make use of this feature, the following procedure should be used:

1. Make sure that the ADC is enabled and is not busy converting. Single Conversion mode must be selected and the ADC conversion complete interrupt must be enabled.
 ADEN = 1
 ADSC = 0
 ADFR = 0
 ADIE = 1
2. Enter ADC Noise Reduction mode (or Idle mode). The ADC will start a conversion once the CPU has been halted.
3. If no other interrupts occur before the ADC conversion completes, the ADC interrupt will wake up the MCU and execute the ADC conversion complete interrupt routine.

The ADC Multiplexer Selection Register – ADMUX

Bit	7	6	5	4	3	2	1	0	
\$07	REFS1	REFS0	ADLAR	–	–	MUX2	MUX1	MUX0	ADMUX
Read/Write	R/W	R/W	R/W	R	R	R/W	R/W	R/W	
Initial Value	0	0	0	0	0	0	0	0	

• Bits 7..6 – REFS1..REFS0: Reference Selection Bits

These bits select the voltage reference for the ADC, as shown in Table 19. If these bits are changed during a conversion, the change will not go into effect until this conversion is complete (ADIF in ADCSR is set). Whenever these bits are changed, the next conversion will take 25 ADC clock cycles. If active channels are used, using AVCC or an external AREF higher than (AVCC - 1V) is not recommended, as this will affect ADC accuracy. The internal voltage reference options may not be used if an external reference voltage is being applied to the AREF pin.

Table 19. Voltage Reference Selections for ADC

REFS1	REFS0	Voltage Reference Selection
0	0	V _{CC} used as analog reference, disconnected from PB0 (AREF).
0	1	External Voltage Reference at PB0 (AREF) pin, Internal Voltage Reference turned off.
1	0	Internal Voltage Reference without external bypass capacitor, disconnected from PB0 (AREF).
1	1	Internal Voltage Reference with external bypass capacitor at PB0 (AREF) pin.

• Bit 5 – ADLAR: ADC Left Adjust Result

The ADLAR bit affects the presentation of the ADC conversion result in the ADC Data Register. If ADLAR is cleared, the result is right-adjusted. If ADLAR is set, the result is left-adjusted. Changing the ADLAR bit will affect the ADC Data Register immediately, regardless of any ongoing conversions. For a complete description of this bit, see “The ADC Data Register – ADCL and ADCH” on page 49.

- **Bits 4..3 – Res: Reserved Bits**

These bits are reserved bits in the ATtiny15L and always read as zero.

- **Bits 2..0 – MUX2..MUX0: Analog Channel and Gain Selection Bits 2..0**

The value of these bits selects which analog input is connected to the ADC. In case of differential input (PB3 - PB4), gain selection is also made with these bits. Selecting PB3 as both inputs to the differential gain stage enables offset measurements. Refer to Table 20 for details. If these bits are changed during a conversion, the change will not go into effect until this conversion is complete (ADIF in ADCSR is set).

Table 20. Input Channel and Gain Selections

MUX2..0	Single-ended Input	Positive Differential Input	Negative Differential Input	Gain
000	ADC0 (PB5)	N/A		
001	ADC1 (PB2)			
010	ADC2 (PB3)			
011	ADC3 (PB4)			
100 ⁽¹⁾	N/A	ADC2 (PB3)	ADC2 (PB3)	1x
101 ⁽¹⁾		ADC2 (PB3)	ADC2 (PB3)	20x
110		ADC2 (PB3)	ADC3 (PB4)	1x
111		ADC2 (PB3)	ADC3 (PB4)	20x

Note: 1. For offset calibration only. See “Operation” on page 42.

The ADC Control and Status Register – ADCSR

Bit	7	6	5	4	3	2	1	0	
\$06	ADEN	ADSC	ADFR	ADIF	ADIE	ADPS2	ADPS1	ADPS0	ADCSR
Read/Write	R/W	R/W	R/W	R/W	R/W	R/W	R/W	R/W	
Initial Value	0	0	0	0	0	0	0	0	

- **Bit 7 – ADEN: ADC Enable**

Writing a logical “1” to this bit enables the ADC. By clearing this bit to zero, the ADC is turned off. Turning the ADC off while a conversion is in progress will terminate this conversion.

- **Bit 6 – ADSC: ADC Start Conversion**

In Single Conversion mode, a logical “1” must be written to this bit to start each conversion. In Free Running mode, a logical “1” must be written to this bit to start the first conversion.

When the conversion completes, ADSC returns to zero in Single Conversion mode and stays high in Free Running mode.

Writing a “0” to this bit has no effect.

- **Bit 5 – ADFR: ADC Free Running Select**

When this bit is set (one), the ADC operates in Free Running mode. In this mode, the ADC samples and updates the Data Registers continuously. Clearing this bit (zero) will terminate Free Running mode. If active channels are used (MUX2 in ADMUX set), the

channel must be selected before entering Free Running mode. Selecting an active channel after entering Free Running mode may result in undefined operation from the ADC.

- **Bit 4 – ADIF: ADC Interrupt Flag**

This bit is set (one) when an ADC conversion completes and the Data Registers are updated. The ADC Conversion Complete Interrupt is executed if the ADIE bit and the I-bit in SREG are set (one). ADIF is cleared by hardware when executing the corresponding interrupt handling vector. Alternatively, ADIF is cleared by writing a logical “1” to the flag. Beware that if doing a read-modify-write on ADCSR, a pending interrupt can be disabled. This also applies if the SBI and CBI instructions are used.

- **Bit 3 – ADIE: ADC Interrupt Enable**

When this bit is set (one) and the I-bit in SREG is set (one), the ADC Conversion Complete Interrupt is activated.

- **Bits 2..0 – ADPS2..ADPS0: ADC Prescaler Select Bits**

These bits determine the division factor between the CK frequency and the input clock to the ADC. See Table 21.

Table 21. ADC Prescaler Selections

ADPS2	ADPS1	ADPS0	Division Factor
0	0	0	2
0	0	1	2
0	1	0	4
0	1	1	8
1	0	0	16
1	0	1	32
1	1	0	64
1	1	1	128

The ADC Data Register – ADCL and ADCH

ADLAR = 0

Bit	15	14	13	12	11	10	9	8	
\$05	–	–	–	–	–	–	ADC9	ADC8	ADCH
\$04	ADC7	ADC6	ADC5	ADC4	ADC3	ADC2	ADC1	ADC0	ADCL
	7	6	5	4	3	2	1	0	
Read/Write	R	R	R	R	R	R	R	R	
	R	R	R	R	R	R	R	R	
Initial Value	0	0	0	0	0	0	0	0	
	0	0	0	0	0	0	0	0	

ADLAR = 1

Bit	15	14	13	12	11	10	9	8	
\$05	ADC9	ADC8	ADC7	ADC6	ADC5	ADC4	ADC3	ADC2	ADCH
\$04	ADC1	ADC0	–	–	–	–	–	–	ADCL
	7	6	5	4	3	2	1	0	
Read/Write	R	R	R	R	R	R	R	R	
	R	R	R	R	R	R	R	R	
Initial Value	0	0	0	0	0	0	0	0	
	0	0	0	0	0	0	0	0	

When an ADC conversion is complete, the result is found in these two registers. When ADCL is read, the ADC Data Register is not updated until ADCH is read. If the result is left adjusted and no more than 8-bit precision is required, it is sufficient to read ADCH. Otherwise, ADCL must be read first, then ADCH. The ADLAR bit in ADMUX affects the way the result is read from the registers. If ADLAR is set, the result is left-adjusted. If ADLAR is cleared (default), the result is right-adjusted.

- **ADC9..0: ADC Conversion Result**

These bits represent the result from the conversion. For the differential channel, this is the value after gain adjustment, as indicated in Table 20 on page 47. For single-ended conversion, or if ADLAR or SIGN is zero, \$000 represents ground and \$3FF represents the selected reference voltage minus one LSB.

Scanning Multiple Channels

Since change of analog channel always is delayed until a conversion is finished, the Free Running mode can be used to scan multiple channels without interrupting the converter. Typically, the ADC Conversion Complete Interrupt will be used to perform the channel shift. However, the user should take the following fact into consideration:

The interrupt triggers once the result is ready to be read. In Free Running mode, the next conversion will start immediately when the interrupt triggers. If ADMUX is changed after the interrupt triggers, the next conversion has already started, and the old setting is used.

ADC Noise-canceling Techniques

Digital circuitry inside and outside the ATtiny15L generates EMI, which might affect the accuracy of analog measurements. If conversion accuracy is critical, the noise level can be reduced by applying the following techniques:

1. The analog part of the ATtiny15L and all analog components in the application should have a separate analog ground plane on the PCB. This ground plane is connected to the digital ground plane via a single point on the PCB.
2. Keep analog signal paths as short as possible. Make sure analog tracks run over the analog ground plane, and keep them well away from high-speed switching digital tracks.
3. Use the ADC noise canceler function to reduce induced noise from the CPU.
4. If some Port B pins are used as digital outputs, it is essential that these do not switch while a conversion is in progress.

ADC Characteristics

Symbol	Parameter	Condition	Min	Typ	Max	Units
	Resolution	Single-ended Conversion		10.0		Bits
		Differential Conversion Gain = 1x or 20x		8.0		Bits
	Absolute Accuracy	Single-ended Conversion $V_{REF} = 4V$ ADC Clock = 200 kHz		1.0	2.0	LSB
		Single-ended Conversion $V_{REF} = 4V$ ADC Clock = 1 MHz		4.0		LSB
		Single-ended Conversion $V_{REF} = 4V$ ADC Clock = 2 MHz		16.0		LSB
	Integral Non-linearity	$V_{REF} > 2V$		0.5		LSB
	Differential Non-linearity	$V_{REF} > 2V$		0.5		LSB
	Zero Error (Offset)	$V_{REF} > 2V$		1.0		LSB
	Conversion Time	Free Running Conversion	65.0		260.0	μs
	Clock Frequency		50.0		200.0	kHz
V_{REF}	Reference Voltage	Single-ended Conversion	2.0		V_{CC}	V
		Differential Conversion	2.0		$V_{CC} - 0.2$	V
V_{INT}	Internal Voltage Reference		2.4	2.56	2.7	V
R_{REF}	Reference Input Resistance		6.0	10.0	13.0	$k\Omega$
R_{AIN}	Analog Input Resistance			100.0		$M\Omega$

I/O Port B

All AVR ports have true read-modify-write functionality when used as general digital I/O ports. This means that the direction of one port pin can be changed without unintentionally changing the direction of any other pin with the SBI and CBI instructions. The same applies for changing drive value (if configured as output) or enabling/disabling of pull-up resistors (if configured as input).

Port B is a 6-bit bi-directional I/O port.

Three data memory address locations are allocated for Port B, one each for the Data Register – PORTB, \$18, Data Direction Register – DDRB, \$17, and the Port B Input Pins – PINB, \$16. The Port B Input Pins address is read-only, while the Data Register and the Data Direction Register are read/write.

Ports PB5..0 have special functions as described in the section “Pin Descriptions” on page 4. If PB5 is not configured as External Reset, it is input with no pull-up or as an open-drain output. All I/O pins have individually selectable pull-ups, which can be overridden with pull-up disable.

The Port B output buffers on PB0 to PB4 can sink 20 mA and thus drive LED displays directly. PB5 can sink 12 mA. When pins PB0 to PB4 are used as inputs and are externally pulled low, they will source current (I_{IL}) if the internal pull-ups are activated.

Unconnected Pins

If some pins are unused, it is recommended to ensure that these pins have a defined level. The simplest method to ensure a defined level of an unused pin, is to enable the internal pull-up. In this case, the pull-up will be disabled during reset. If low power consumption during reset is important, it is recommended to use an external pull-up or pull-down. Connecting unused pins directly to Vcc or GND is not recommended, since this may cause excessive currents if the pin is accidentally configured as an output.

Alternative Functions of Port B

In ATtiny15L four Port B pins – PB2, PB3, PB4, and PB5 – have alternative functions as inputs for the ADC. If some Port B pins are configured as outputs, it is essential that these do not switch when a conversion is in progress. This might corrupt the result of the conversion. During Power-down mode and ADC Noise Reduction mode, the Schmitt triggers of the digital inputs are disconnected on these pins. This allows an analog input voltage close to $V_{CC}/2$ to be present during Power-down without causing excessive power consumption. The Port B pins with alternate functions are shown in Table 1 on page 4.

When the pins PB4..0 are used for the alternate function, the DDRB and PORTB Registers have to be set according to the alternate function description. When PB5 is used as External Reset pin, the values in the corresponding DDRB and PORTB bit are ignored.

The Port B Data Register – PORTB

Bit	7	6	5	4	3	2	1	0	
\$18	–	–	–	PORTB4	PORTB3	PORTB2	PORTB1	PORTB0	PORTB
Read/Write	R	R	R	R/W	R/W	R/W	R/W	R/W	
Initial Value	0	0	0	0	0	0	0	0	

The Port B Data Direction Register – DDRB

Bit	7	6	5	4	3	2	1	0	
\$17	–	–	DDB5	DDB4	DDB3	DDB2	DDB1	DDB0	DDR
Read/Write	R	R	R/W	R/W	R/W	R/W	R/W	R/W	
Initial Value	0	0	0	0	0	0	0	0	



The Port B Input Pins Address – PINB

Bit	7	6	5	4	3	2	1	0	
\$16	–	–	PINB5	PINB4	PINB3	PINB2	PINB1	PINB0	PINB
Read/Write	R	R	R	R	R	R	R	R	
Initial Value	0	0	N/A	N/A	N/A	N/A	N/A	N/A	

The Port B Input Pins address (PINB) is not a register, and this address enables access to the physical value on each Port B pin. When reading PORTB, the PORTB Data Latch is read, and when reading PINB, the logical values present on the pins are read.

PORT B as General Digital I/O

The lower five pins in Port B are equal when used as digital I/O pins.

PB_n, general I/O pin: The DDB_n bit in the DDRB Register selects the direction of this pin. If DDB_n is set (one), PB_n is configured as an output pin. If DDB_n is cleared (zero), PB_n is configured as an input pin. If PORTB_n is set (one) when the pin is configured as an input pin, the MOS pull-up resistor is activated. To switch the pull-up resistor off, the PORTB_n has to be cleared (zero) or the pin has to be configured as an output pin. Pull-ups for all ports can be disabled also by setting PUD-bit in the MCUCR Register.

Table 22. DDB_n Effects on Port B Pins⁽¹⁾

DDB _n	PORTB _n	I/O	Pull-up	Comment
0	0	Input	No	Tri-state (High-Z)
0	1	Input	No	PUD bit in the MCUCR Register is set.
0	1	Input	Yes	PB _n will source current if ext. pulled low. PUD bit in the MCUCR Register is cleared.
1	0	Output	No	Push-pull Zero Output
1	1	Output	No	Push-pull One Output

Note: 1. n: 4, 3...0, pin number.

On ATtiny15L, PB5 is input or open-drain output. Because this pin is used for 12V programming, there is no ESD protection diode limiting the voltage on the pin to $V_{CC} + 0.5V$. Thus, special care should be taken to ensure that the voltage on this pin does not rise above $V_{CC} + 1V$ during normal operation. This may cause the MCU to reset or enter Programming mode unintentionally.

All Port B pins are connected to a pin change detector that can trigger the pin change interrupt. See “Pin Change Interrupt” on page 22 for details.

Alternate Functions of Port B

The alternate pin functions of Port B are:

- **RESET – PORT B, Bit 5**

When the RSTDISBL Fuse is unprogrammed, this pin serves as External Reset. When the RSTDISBL Fuse is programmed, this pin is a general input pin or an open-drain output pin. If DDB5 is cleared (zero), PB5 is configured as an input pin. If DDB5 is set (one), the pin is an open-drain output.

- **SCK/INT0/T0 – PORT B, Bit 2**

In Serial Programming mode, this pin serves as the serial clock input, SCK.

In Normal mode, this pin can serve as the external interrupt0 input. See the interrupt description for details on how to enable this interrupt. Note that activity on this pin will trigger the interrupt even if the pin is configured as an output.

In Normal mode, this pin can serve as the external counter clock input. See the Timer/Counter0 description for further details. If external Timer/Counter clocking is selected, activity on this pin will clock the counter even if it is configured as an output.

- **MISO/OC1A/AIN1 – PORT B, Bit 1**

In Serial Programming mode, this pin serves as the serial data output, MISO.

In Normal mode, this pin can serve as Timer/Counter1 output compare match output (OC1A). See the Timer/Counter1 description for further details, and how to enable the output. The OC1A pin is also the output pin for PWM mode timer function.

This pin also serves as the negative input of the On-chip Analog Comparator.

- **MOSI/AIN0/AREF – PORT B, Bit 0**

In Serial Programming mode, this pin serves as the serial data input, MOSI.

In Normal mode, this pin also serves as the positive input of the On-chip Analog Comparator.

In ATtiny15L, this pin can be chosen to be the reference voltage for the ADC. Refer to the section “The Analog-to-Digital Converter, Analog Multiplexer, and Gain Stages” for details.

Memory Programming

Program and Data Memory Lock Bits

The ATtiny15L MCU provides two Lock bits that can be left unprogrammed, “1”, or can be programmed, “0”, to obtain the additional features listed in Table 23. The Lock bits can only be erased with the Chip Erase command.

Table 23. Lock Bit Protection Modes

Memory Lock Bits			Protection Type
Mode	LB1	LB2	
1	1	1	No memory lock features enabled.
2	0	1	Further programming of the Flash and EEPROM is disabled.
3	0	0	Same as mode 2, but verify is also disabled.

Fuse Bits

The ATtiny15L has six Fuse bits (BODLEVEL, BODEN, SPIEN, RSTDSBL, and CKSEL1..0). All the Fuse bits are programmable in both High-voltage and Low-voltage Serial Programming modes. Changing the Fuses does not have effect while in programming mode.

- The BODLEVEL Fuse selects the Brown-out Detection level and changes the start-up times. See “Brown-out Detection” on page 17. See Table 5 on page 15. Default value is programmed “0”.
- When the BODEN Fuse is programmed “0”, the Brown-out Detector is enabled. See “Brown-out Detection” on page 17. Default value is unprogrammed “1”.
- When the SPIEN Fuse bit is programmed “0”, Low-voltage Serial Program and Data Downloading is enabled. Default value is programmed “0”. Unprogramming this fuse while in the Low-voltage Serial Programming mode will disable future In-System downloading attempts.
- When the RSTDISBL Fuse is programmed “0”, the External Reset function of pin PB5 is disabled⁽¹⁾. Default value is unprogrammed “1”. Programming this fuse while in the Low-voltage Serial Programming mode will disable future In-System downloading attempts.
- CKSEL1..0 Fuses: See Table 5 on page 15 for which combination of CKSEL1..0 to use. Default value is “00”, 64 ms + 18 CK.

The status of the Fuse bits is not affected by Chip Erase.

Note: 1. If the RSTDISBL Fuse is programmed, then the programming hardware should apply +12V to PB5 while the ATtiny15L is in Power-on Reset. If not, the part can fail to enter Programming mode caused by drive contention on PB0 and/or PB5.

Signature Bytes

All Atmel microcontrollers have a three-byte signature code that identifies the device.

The three bytes reside in a separate address space, and for the ATtiny15L they are:

1. \$000 : \$1E (indicates manufactured by Atmel).
2. \$001 : \$90 (indicates 1 Kb Flash memory).
3. \$002 : \$06 (indicates ATtiny15L device when \$001 is \$90).

Calibration Byte

The ATtiny15L has a one-byte calibration value for the internal RC Oscillator. This byte resides in the high byte of address \$000 in the signature address space. To make use of this byte, it should be read from this location and written into the normal Flash Program memory. At start-up, the user software must read this Flash location and write the value to the OSCCAL Register.

Programming the Flash

Atmel's ATtiny15L offers 1K byte of In-System Reprogrammable Flash Program memory and 64 bytes of in-System Reprogrammable EEPROM Data memory.

The ATtiny15L is shipped with the On-chip Flash program and EEPROM data memory arrays in the erased state (i.e., contents = \$FF) and ready to be programmed.

This device supports a High-voltage (12V) Serial Programming mode and a Low-voltage Serial Programming mode. The +12V is used for programming enable only, and no current of significance is drawn by this pin (less than 100 μ A). The Low-voltage Serial Programming mode provides a convenient way to download program and data into the ATtiny15L inside the user's system.

The Program and Data memory arrays in the ATtiny15L are programmed byte-by-byte in either Programming mode. For the EEPROM, an auto-erase cycle is provided within the self-timed write instruction in the Low-voltage Serial Programming mode.

During programming, the supply voltage must be in accordance with Table 24.

Table 24. Supply Voltage during Programming

Part	Low-voltage Serial Programming	High-voltage Serial Programming
ATtiny15L	2.7 - 5.5V	4.5 - 5.5V

High-voltage Serial Programming

This section describes how to program and verify Flash Program memory, EEPROM Data memory, Lock bits and Fuse bits in the ATtiny15L.

Figure 30. High-voltage Serial Programming

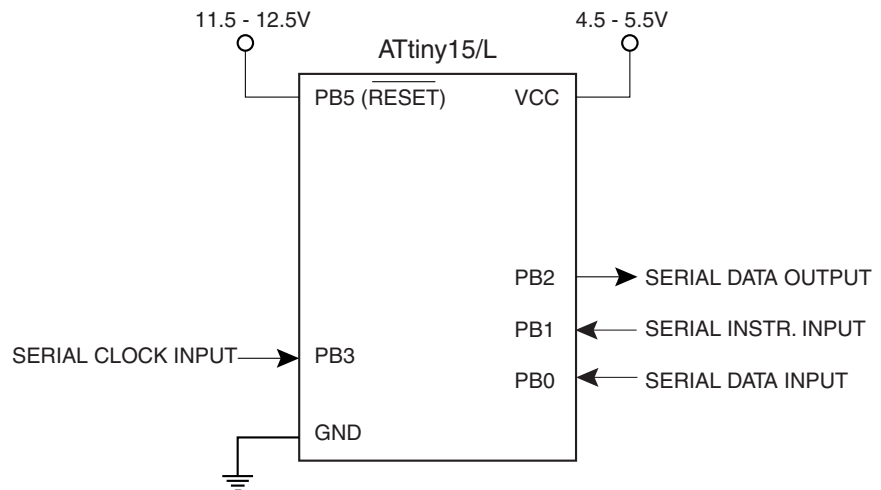

High-voltage Serial Programming Algorithm

To program and verify the ATtiny15L in the High-voltage Serial Programming mode, the following sequence is recommended (See instruction formats in Table 25):

1. Power-up sequence:
 - Apply 4.5 - 5.5V between V_{CC} and GND. Set PB5 and PB0 to "0" and wait at least 30 μ s.
 - Set PB3 to "0". Wait at least 100 ns.
 - Apply 12V to PB5 and wait at least 100 ns before changing PB0. Wait 8 μ s before giving any instructions.
2. The Flash array is programmed one byte at a time by supplying first the address, then the low and high data byte. The write instruction is self-timed; wait until the PB2 (RDY/BSY) pin goes high.
3. The EEPROM array is programmed one byte at a time by supplying first the address, then the data byte. The write instruction is self-timed; wait until the PB2 (RDY/BSY) pin goes high.
4. Any memory location can be verified by using the Read instruction, which returns the contents at the selected address at serial output PB2.
5. Power-off sequence:
 - Set PB3 to "0".
 - Set PB5 to "0".
 - Turn V_{CC} power off.

When writing or reading serial data to the ATtiny15L, data is clocked on the eighth rising edge of the 16 external clock pulses needed to generate the internal clock. See Figure 31, Figure 32, and Table 26 for an explanation.

Figure 31. High-voltage Serial Programming Waveforms

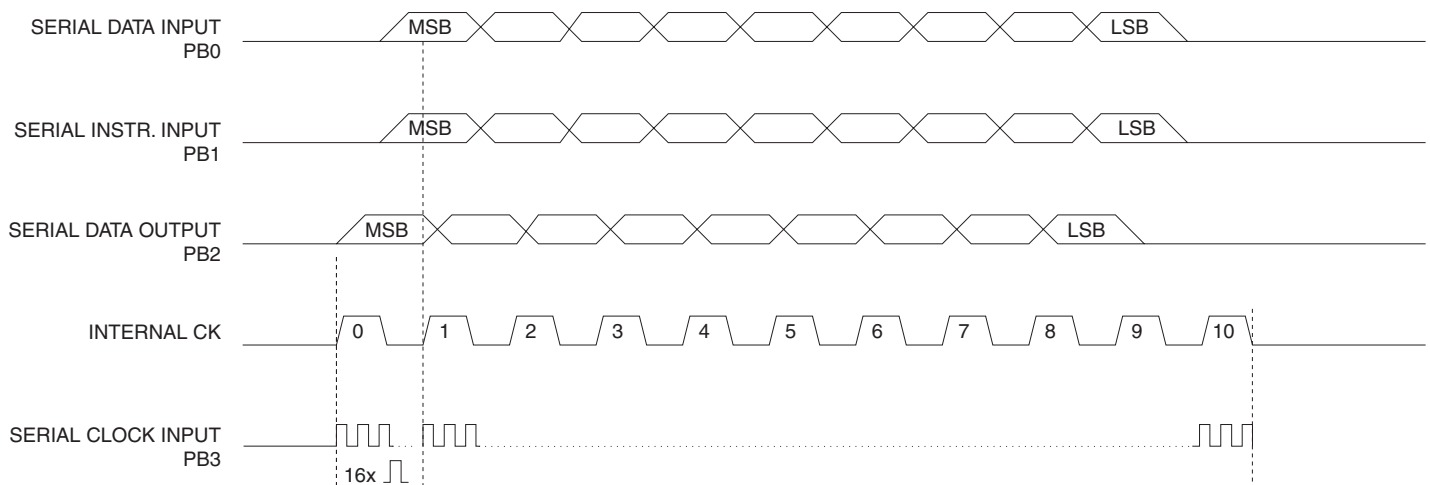

Table 25. High-voltage Serial Programming Instruction Set for ATtiny15L⁽¹⁾

Instruction		Instruction Format				Operation Remarks
		Instr.1	Instr.2	Instr.3	Instr.4	
Chip Erase	PB0	0_1000_0000_00	0_0000_0000_00	0_0000_0000_00	0_0000_0000_00	Wait after Instr.3 until PB2 goes high for the Chip Erase cycle to finish.
	PB1	0_0100_1100_00	0_0110_0100_00	0_0110_1100_00	0_0100_1100_00	
	PB2	x_xxxx_xxxx_xx	x_xxxx_xxxx_xx	x_xxxx_xxxx_xx	x_xxxx_xxxx_xx	
Write Flash High and Low Address	PB0	0_0001_0000_00	0_0000_000a_00	0_bbbb_bbbb_00		Repeat Instr.2 for a new 256 byte page. Repeat Instr.3 for each new address.
	PB1	0_0100_1100_00	0_0001_1100_00	0_0000_1100_00		
	PB2	x_xxxx_xxxx_xx	x_xxxx_xxxx_xx	x_xxxx_xxxx_xx		
Write Flash Low Byte	PB0	0_iiii_iiii_00	0_0000_0000_00	0_0000_0000_00		Wait after Instr.3 until PB2 goes high. Repeat Instr.1, Instr. 2 and Instr.3 for each new address.
	PB1	0_0010_1100_00	0_0110_0100_00	0_0110_1100_00		
	PB2	x_xxxx_xxxx_xx	x_xxxx_xxxx_xx	0_0000_0000_00		
Write Flash High Byte	PB0	0_iiii_iiii_00	0_0000_0000_00	0_0000_0000_00		Wait after Instr.3 until PB2 goes high. Repeat Instr.1, Instr. 2 and Instr.3 for each new address.
	PB1	0_0011_1100_00	0_0111_0100_00	0_0111_1100_00		
	PB2	x_xxxx_xxxx_xx	x_xxxx_xxxx_xx	0_0000_0000_00		
Read Flash High and Low Address	PB0	0_0000_0010_00	0_0000_000a_00	0_bbbb_bbbb_00		Repeat Instr.2 and Instr.3 for each new address.
	PB1	0_0100_1100_00	0_0001_1100_00	0_0000_1100_00		
	PB2	x_xxxx_xxxx_xx	x_xxxx_xxxx_xx	x_xxxx_xxxx_xx		
Read Flash Low Byte	PB0	0_0000_0000_00	0_0000_0000_00			Repeat Instr.1 and Instr.2 for each new address.
	PB1	0_0110_1000_00	0_0110_1100_00			
	PB2	x_xxxx_xxxx_xx	0_0000_000x_xx			
Read Flash High Byte	PB0	0_0000_0000_00	0_0000_0000_00			Repeat Instr.1 and Instr.2 for each new address.
	PB1	0_0111_1000_00	0_0110_1100_00			
	PB2	x_xxxx_xxxx_xx	0_0000_000x_xx			
Write EEPROM Low Address	PB0	0_0001_0001_00	0_00bb_bbbb_00			Repeat Instr.2 for each new address.
	PB1	0_0100_1100_00	0_0000_1100_00			
	PB2	x_xxxx_xxxx_xx	x_xxxx_xxxx_xx			
Write EEPROM Byte	PB0	0_iiii_iiii_00	0_0000_0000_00	0_0000_0000_00		Wait after Instr.3 until PB2 goes high
	PB1	0_0010_1100_00	0_0110_0100_00	0_0110_1100_00		
	PB2	x_xxxx_xxxx_xx	x_xxxx_xxxx_xx	0_0000_0000_00		
Read EEPROM Low Address	PB0	0_0000_0011_00	0_00bb_bbbb_00			Repeat Instr.2 for each new address.
	PB1	0_0100_1100_00	0_0000_1100_00			
	PB2	x_xxxx_xxxx_xx	x_xxxx_xxxx_xx			
Read EEPROM Byte	PB0	0_0000_0000_00	0_0000_0000_00			Repeat Instr.2 for each new address
	PB1	0_0110_1000_00	0_0110_1100_00			
	PB2	x_xxxx_xxxx_xx	0_0000_000x_xx			
Write Fuse Bits	PB0	0_0100_0000_00	0_8765_1143_00	0_0000_0000_00	0_0000_0000_00	Wait after Instr.4 until PB2 goes high. Write 8 - 3 = "0" to program the Fuse bit.
	PB1	0_0100_1100_00	0_0010_1100_00	0_0110_0100_00	0_0110_1100_00	
	PB2	x_xxxx_xxxx_xx	x_xxxx_xxxx_xx	x_xxxx_xxxx_xx	x_xxxx_xxxx_xx	
Write Lock Bits	PB0	0_0010_0000_00	0_0000_0270_00	0_0000_0000_00	0_0000_0000_00	Wait after Instr.4 until PB2 goes high. Write 2, 1 = "0" to program the Lock bit.
	PB1	0_0100_1100_00	0_0010_1100_00	0_0110_0100_00	0_0110_1100_00	
	PB2	x_xxxx_xxxx_xx	x_xxxx_xxxx_xx	x_xxxx_xxxx_xx	0_0000_0000_00	
Read Fuse Bits	PB0	0_0000_0100_00	0_0000_0000_00	0_0000_0000_00		Reading 8 - 3 = "0" means the Fuse bit is programmed.
	PB1	0_0100_1100_00	0_0110_1000_00	0_0110_1100_00		
	PB2	x_xxxx_xxxx_xx	x_xxxx_xxxx_xx	8_765x_x43x_xx		

Table 25. High-voltage Serial Programming Instruction Set for ATtiny15L⁽¹⁾ (Continued)

Instruction		Instruction Format				Operation Remarks
		Instr.1	Instr.2	Instr.3	Instr.4	
Read Lock Bits	PB0	0_0000_0100_00	0_0000_0000_00	0_0000_0000_00		Reading 2 , 1 = "0" means the Lock bit is programmed
	PB1	0_0100_1100_00	0_0111_1000_00	0_0111_1100_00		
	PB2	x_xxxx_xxxx_xx	x_xxxx_xxxx_xx	x_xxxx_21xx_xx		
Read Signature Bytes	PB0	0_0000_1000_00	0_0000_00 bb _00	0_0000_0000_00	0_0000_0000_00	Repeat Instr.2 - Instr.4 for each signature byte address
	PB1	0_0100_1100_00	0_0000_1100_00	0_0110_1000_00	0_0110_1100_00	
	PB2	x_xxxx_xxxx_xx	x_xxxx_xxxx_xx	x_xxxx_xxxx_xx	o_0000_000x_xx	
Read Calibration Byte	PB0	0_0000_1000_00	0_0000_0000_00	0_0000_0000_00	0_0000_0000_00	
	PB1	0_0100_1100_00	0_0000_1100_00	0_0111_1000_00	0_0111_1100_00	
	PB2	x_xxxx_xxxx_xx	x_xxxx_xxxx_xx	x_xxxx_xxxx_xx	o_0000_000x_xx	

Note: 1. **a** = address high bits

b = address low bits

i = data in

o = data out

x = don't care

1 = Lock Bit1

2 = Lock Bit2

3 = CKSEL0 Fuse

4 = CKSEL1 Fuse

5 = RSTDSBL Fuse

6 = SPIEN Fuse

7 = BODEN Fuse

8 = BODLEVEL Fuse

The Lock bits can only be cleared by executing a Chip Erase.

High-voltage Serial Programming Characteristics

Figure 32. High-voltage Serial Programming Timing

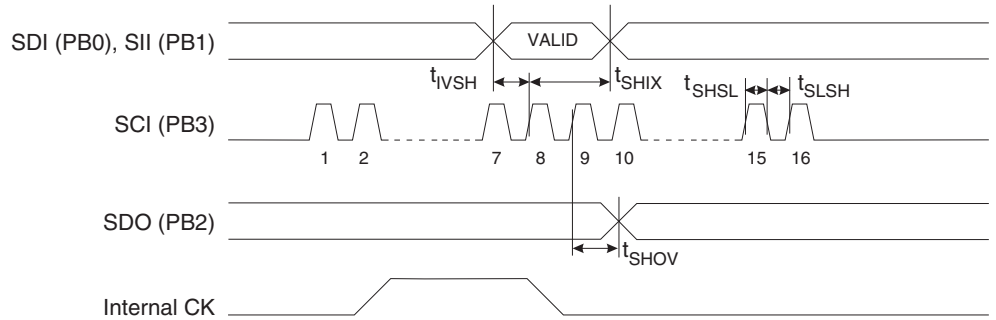

Table 26. High-voltage Serial Programming Characteristics, $T_A = 25^\circ\text{C} \pm 10\%$, $V_{CC} = 5.0\text{V} \pm 10\%$ (unless otherwise noted)

Symbol	Parameter	Min	Typ	Max	Units
t_{SHSL}	SCI (PB3) Pulse Width High	25.0			ns
t_{SLSH}	SCI (PB3) Pulse Width Low	25.0			ns
t_{IVSH}	SDI (PB0), SII (PB1) Valid to SCI (PB3) High (8th edge)	50.0			ns
t_{SHIX}	SDI (PB0), SII (PB1) Hold after SCI (PB3) High (8th edge)	50.0			ns
t_{SHOV}	SCI (PB3) High (9th edge) to SDO (PB2) Valid	10.0	16.0	32.0	ns

Low-voltage Serial Downloading

Both the program and data memory arrays can be programmed using the SPI bus while $\overline{\text{RESET}}$ is pulled to GND. The serial interface consists of pins SCK, MOSI (input) and MISO (output). See Figure 33. After $\overline{\text{RESET}}$ is set low, the Programming Enable instruction needs to be executed first before program/erase instructions can be executed.

Figure 33. Serial Programming and Verify

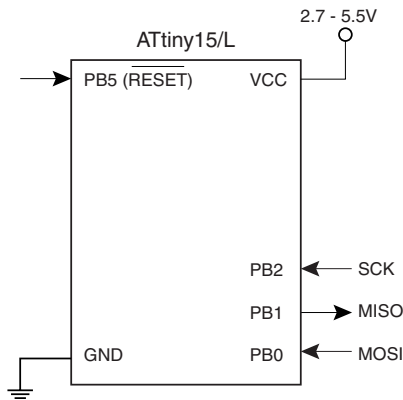

For the EEPROM, an auto-erase cycle is provided within the self-timed write instruction and there is no need to first execute the Chip Erase instruction. The Chip Erase instruction turns the content of every memory location in both the program and EEPROM arrays into \$FF.

The program and EEPROM memory arrays have separate address spaces: \$0000 to \$01FF for Program memory and \$000 to \$03F for EEPROM memory.

The device is clocked from the internal clock at the uncalibrated minimum frequency (0.8 - 1.6 MHz). The minimum low and high periods for the serial clock (SCK) input are defined as follows:

- Low: > 2 MCU clock cycles
- High: > 2 MCU clock cycles

Low-voltage Serial Programming Algorithm

When writing serial data to the ATtiny15L, data is clocked on the rising edge of SCK. When reading data from the ATtiny15L, data is clocked on the falling edge of SCK. See Figure 34, Figure 35, and Table 28 for timing details. To program and verify the ATtiny15L in the Serial Programming mode, the following sequence is recommended (See 4-byte instruction formats in Table 27):

1. Power-up sequence:
Apply power between V_{CC} and GND while \overline{RESET} and SCK are set to "0". If the programmer cannot guarantee that SCK is held low during Power-up, \overline{RESET} must be given a positive pulse of at least two MCU cycles duration after SCK has been set to "0".
2. Wait for at least 20 ms and enable serial programming by sending the Programming Enable serial instruction to the MOSI (PB0) pin. Refer to the above section for minimum low and high periods for the serial clock input SCK.
3. The serial programming instructions will not work if the communication is out of synchronization. When in sync, the second byte (\$53) will echo back when issuing the third byte of the Programming Enable instruction. Whether the echo is correct or not, all four bytes of the instruction must be transmitted. If the \$53 did not echo back, give SCK a positive pulse and issue a new Programming Enable instruction. If the \$53 is not seen within 32 attempts, there is no functional device connected.
4. If a Chip Erase is performed (must be done to erase the Flash), wait t_{WD_ERASE} after the instruction, give \overline{RESET} a positive pulse, and start over from step 2. See Table 29 on page 63 for t_{WD_ERASE} value.
5. The Flash or EEPROM array is programmed one byte at a time by supplying the address and data together with the appropriate write instruction. An EEPROM memory location is first automatically erased before new data is written. Use data polling to detect when the next byte in the Flash or EEPROM can be written. If polling is not used, wait $t_{WD_PROG_FL}$ or $t_{WD_PROG_EE}$, respectively, before transmitting the next instruction. See Table 30 on page 63 for the $t_{WD_PROG_FL}$ and $t_{WD_PROG_EE}$ values. In an erased device, no \$FFs in the data file(s) need to be programmed.
6. Any memory location can be verified by using the Read instruction, which returns the content at the selected address at the serial output MISO (PB1) pin.
7. At the end of the programming session, \overline{RESET} can be set high to commence normal operation.
8. Power-off sequence (if needed):
Set \overline{RESET} to "1".
Turn V_{CC} power off.

Data Polling

When a byte is being programmed into the Flash or EEPROM, reading the address location being programmed will give the value \$FF. At the time the device is ready for a new byte, the programmed value will read correctly. This is used to determine when the next byte can be written. This will not work for the value \$FF so when programming this value, the user will have to wait for at least $t_{WD_PROG_FL}$ before programming the next Flash byte, or $t_{WD_PROG_EE}$ before the next EEPROM byte. As a chip-erased device contains \$FF in all locations, programming of addresses that are meant to contain \$FF can be skipped. This does not apply if the EEPROM is reprogrammed without chip-erasing the device. In that case, data polling cannot be used for the value \$FF and the user will have to wait at least $t_{WD_PROG_EE}$ before programming the next byte. See Table 30 for $t_{WD_PROG_FL}$ and $t_{WD_PROG_EE}$ values.

Figure 34. Low-voltage Serial Programming Waveforms

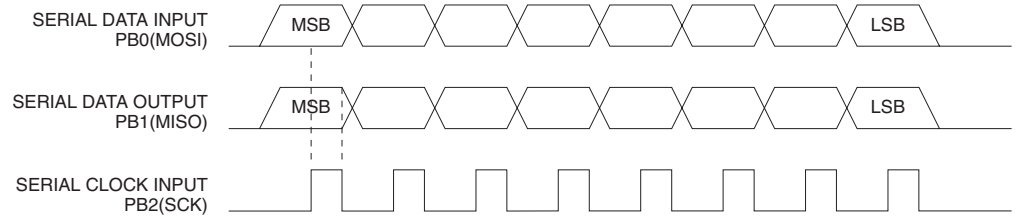

Table 27. Low-voltage Serial Programming Instruction Set⁽¹⁾

Instruction	Instruction Format				Operation
	Byte 1	Byte 2	Byte 3	Byte4	
Programming Enable	1010 1100	0101 0011	xxxx xxxx	xxxx xxxx	Enable Serial Programming while RESET is low.
Chip Erase	1010 1100	100x xxxx	xxxx xxxx	xxxx xxxx	Chip Erase Flash and EEPROM memory arrays.
Read Program Memory	0010 H000	xxxx xxxa	bbbb bbbb	oooo oooo	Read H (high or low) data o from program memory at word address a:b .
Write Program Memory	0100 H000	xxxx xxxa	bbbb bbbb	iiii iiii	Write H (high or low) data i to Program memory at word address a:b .
Read EEPROM Memory	1010 0000	xxxx xxxx	xxbb bbbb	oooo oooo	Read data o from EEPROM memory at address b .
Write EEPROM Memory	1100 0000	xxxx xxxx	xxbb bbbb	iiii iiii	Write data i to EEPROM memory at address b .
Write Lock Bits	1010 1100	1111 1211	xxxx xxxx	xxxx xxxx	Write Lock bits. Set bits 1,2 = "0" to program Lock bits.
Read Lock Bits	0101 1000	xxxx xxxx	xxxx xxxx	xxxx x21x	Read Lock bits. "0" = programmed, "1" = unprogrammed.
Read Signature Bytes	0011 0000	xxxx xxxx	0000 00bb	oooo oooo	Read signature byte o at address b .
Write Fuse Bits	1010 1100	101x xxxx	xxxx xxxx	8765 1143	Set bits 8 - 3 = "0" to program, "1" to unprogram.
Read Fuse Bits	0101 0000	xxxx xxxx	xxxx xxxx	8765 xx43	Read Fuse bits. "0" = programmed, "1" = unprogrammed.
Read Calibration Byte	0011 1000	xxxx xxxx	0000 0000	oooo oooo	

Note: 1. **a** = address high bits
b = address low bits
H = 0 – low byte, 1 – high byte
o = data out
i = data in
x = don't care
1 = Lock bit 1
2 = Lock bit 2
3 = CKSEL0 Fuse
4 = CKSEL1 Fuse
5 = RSTDISBL Fuse
6 = SPIEN Fuse
7 = BODEN Fuse
8 = BODLEVEL Fuse

Low-voltage Serial Programming Characteristics

Figure 35. Low-voltage Serial Programming Timing

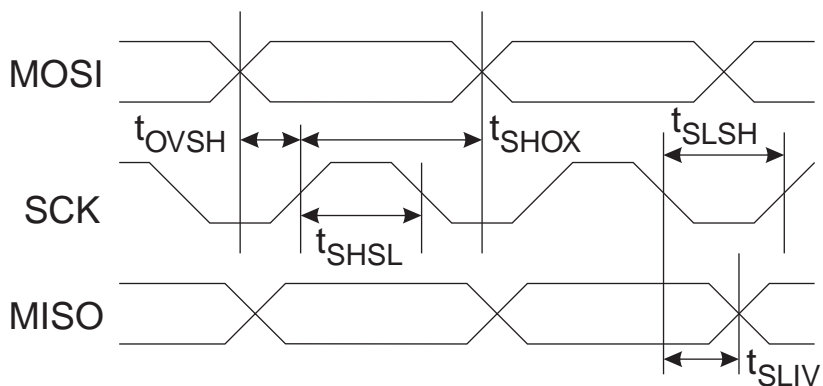

Table 28. Low-voltage Serial Programming Characteristics, $T_A = -40^\circ\text{C}$ to 85°C , $V_{CC} = 2.7 - 5.5\text{V}$ (Unless Otherwise Noted)

Symbol	Parameter	Min	Typ	Max	Units
$1/t_{CLCL}$	RC Oscillator Frequency ($V_{CC} = 2.7 - 5.5\text{V}$)	0.8	1.6		MHz
t_{CLCL}	RC Oscillator Period ($V_{CC} = 2.7 - 5.5\text{V}$)		625.0	1250.0	ns
t_{SHSL}	SCK Pulse Width High	$2.0 t_{CLCL}$			ns
t_{SLSH}	SCK Pulse Width Low	$2.0 t_{CLCL}$			ns
t_{OVSH}	MOSI Setup to SCK High	t_{CLCL}			ns
t_{SHOX}	MOSI Hold after SCK High	$2.0 t_{CLCL}$			ns
t_{SLIV}	SCK Low to MISO Valid	10.0	16.0	32.0	ns

Table 29. Minimum Wait Delay after the Chip Erase Instruction

Symbol	Minimum Wait Delay
t_{WD_ERASE}	8.2 ms

Table 30. Minimum Wait Delay after Writing a Flash or EEPROM Location

Symbol	Minimum Wait Delay
t_{WD_FLASH}	4.1 ms
t_{WD_EEPROM}	8.2 ms

Electrical Characteristics

Absolute Maximum Ratings

Operating Temperature.....	-55°C to +125°C
Storage Temperature.....	-65°C to +150°C
Voltage on Any Pin Except $\overline{\text{RESET}}$ with Respect to Ground.....	-1.0V to $V_{CC} + 0.5V$
Voltage on $\overline{\text{RESET}}$ with Respect to Ground.....	-1.0V to +13.0V
Maximum Operating Voltage.....	6.0V
DC Current per I/O Pin.....	40.0 mA
DC Current V_{CC} and GND Pins.....	100.0 mA

*NOTICE: Stresses beyond those listed under “Absolute Maximum Ratings” may cause permanent damage to the device. This is a stress rating only and functional operation of the device at these or other conditions beyond those indicated in the operational sections of this specification is not implied. Exposure to absolute maximum rating conditions for extended periods may affect device reliability.

DC Characteristics

$T_A = -40^\circ\text{C}$ to 85°C , $V_{CC} = 2.7V$ to $5.5V$

Symbol	Parameter	Condition	Min	Typ	Max	Units
V_{IL}	Input Low Voltage	Except (XTAL)	-0.5		$0.3 V_{CC}^{(1)}$	V
V_{IL1}	Input Low Voltage	XTAL	-0.5		$0.1 V_{CC}^{(1)}$	V
V_{IH}	Input High Voltage	Except (XTAL, $\overline{\text{RESET}}$)	$0.6 V_{CC}^{(2)}$		$V_{CC} + 0.5$	V
V_{IH1}	Input High Voltage	XTAL	$0.7 V_{CC}^{(2)}$		$V_{CC} + 0.5$	V
V_{IH2}	Input High Voltage	$\overline{\text{RESET}}$	$0.85 V_{CC}^{(2)}$		$V_{CC} + 0.5$	V
V_{OL}	Output Low Voltage ⁽¹⁾ Port B	$I_{OL} = 20 \text{ mA}$, $V_{CC} = 5V$			0.6	V
		$I_{OL} = 10 \text{ mA}$, $V_{CC} = 3V$			0.5	V
V_{OL}	Output Low Voltage PB5	$I_{OL} = 12 \text{ mA}$, $V_{CC} = 5V$			0.6	V
		$I_{OL} = 6 \text{ mA}$, $V_{CC} = 3V$			0.5	V
V_{OH}	Output High Voltage ⁽⁴⁾ Port B	$I_{OH} = -3 \text{ mA}$, $V_{CC} = 5V$	4.3			V
		$I_{OH} = -1.5 \text{ mA}$, $V_{CC} = 3V$	2.3			V
I_{IL}	Input Leakage Current I/O Pin	$V_{CC} = 5.5V$, Pin Low (absolute value)			8.0	μA
I_{IH}	Input Leakage Current I/O Pin	$V_{CC} = 5.5V$, Pin High (absolute value)			8.0	μA
$R_{I/O}$	I/O Pin Pull-up		35.0		122	$k\Omega$
I_{CC}	Power Supply Current	Active, $V_{CC} = 3V$			3.0	mA
		Idle, $V_{CC} = 3V$		1.0	1.2	mA
		Power-down ⁽²⁾ , $V_{CC} = 3V$ WDT enabled		9.0	15.0	μA
		Power-down ⁽²⁾ , $V_{CC} = 3V$ WDT disabled		<1.0	2.0	μA

DC Characteristics (Continued)

$T_A = -40^{\circ}\text{C}$ to 85°C , $V_{CC} = 2.7\text{V}$ to 5.5V

Symbol	Parameter	Condition	Min	Typ	Max	Units
V_{ACIO}	Analog Comparator Input Offset Voltage	$V_{CC} = 5\text{V}$ $V_{IN} = V_{CC}/2$			40.0	mV
I_{ACLK}	Analog Comparator Input Leakage Current	$V_{CC} = 5\text{V}$ $V_{IN} = V_{CC}/2$	-50.0		50.0	nA
T_{ACID}	Analog Comparator Initialization Delay	$V_{CC} = 2.7\text{V}$ $V_{CC} = 4.0\text{V}$		750.0 500.0		ns

- Note:
1. "Max" means the highest value where the pin is guaranteed to be read as low.
 2. "Min" means the lowest value where the pin is guaranteed to be read as high.
 3. Although each I/O port can sink more than the test conditions (20 mA at $V_{CC} = 5\text{V}$, 10 mA at $V_{CC} = 3\text{V}$) under steady state conditions (non-transient), the following must be observed:
 - 1) The sum of all I_{OL} , for all ports, should not exceed 100 mA.
If I_{OL} exceeds the test condition, V_{OL} may exceed the related specification.
Pins are not guaranteed to sink current greater than the listed test conditions.
 4. Although each I/O port can source more than the test conditions (3 mA at $V_{CC} = 5\text{V}$, 1.5 mA at $V_{CC} = 3\text{V}$) under steady state conditions (non-transient), the following must be observed:
 - 1) The sum of all I_{OH} , for all ports, should not exceed 100 mA.
If I_{OH} exceeds the test condition, V_{OH} may exceed the related specification. Pins are not guaranteed to source current greater than the listed test condition.
 5. Minimum V_{CC} for Power-down is 1.5V (only with BOD disabled).

Typical Characteristics

The following charts show typical behavior. These data are characterized but not tested. All current consumption measurements are performed with all I/O pins configured as inputs and with internal pull-ups enabled.

The current consumption is a function of several factors such as: Operating voltage, operating frequency, loading of I/O pins, switching rate of I/O pins, code executed and ambient temperature. The dominating factors are operating voltage and frequency.

The current drawn from capacitive loaded pins may be estimated (for one pin) as $C_L \cdot V_{CC} \cdot f$ where C_L = load capacitance, V_{CC} = operating voltage and f = average switching frequency of I/O pin.

The difference between current consumption in Power-down mode with Watchdog Timer enabled and Power-down mode with Watchdog Timer disabled represents the differential current drawn by the Watchdog Timer.

Figure 36. Active Supply Current vs. V_{CC}

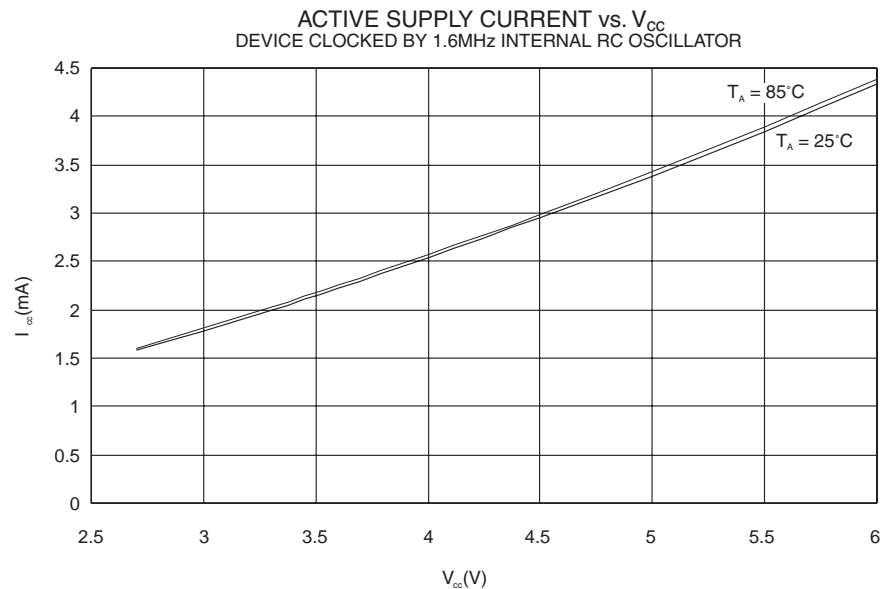

Figure 37. Idle Supply Current vs. V_{CC}

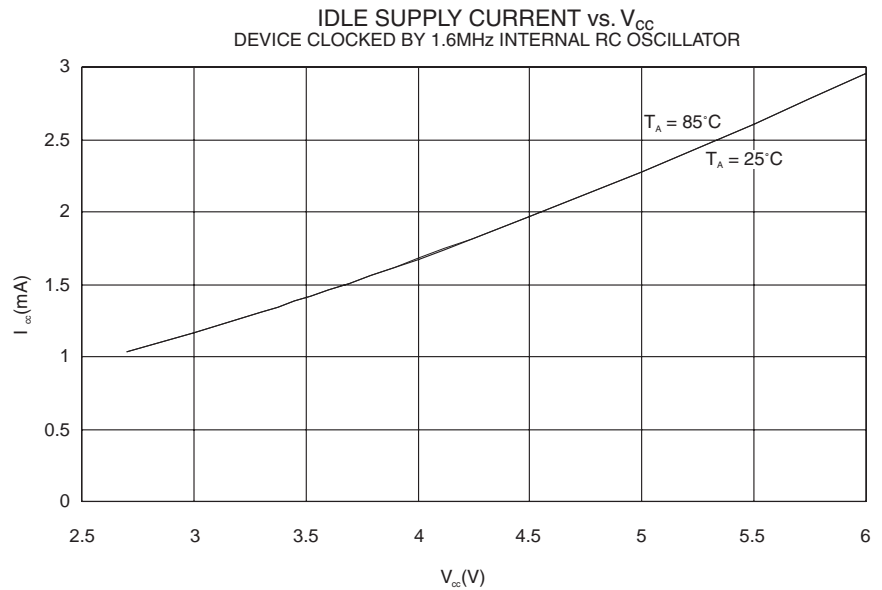
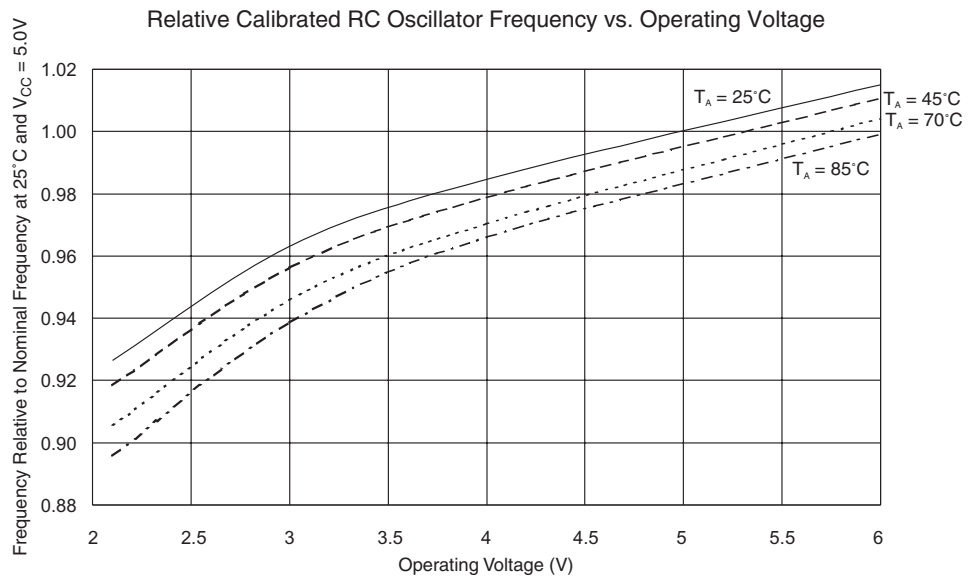

Figure 38. Calibrated Internal RC Oscillator Frequency vs. V_{CC}



Note: The nominal calibrated RC oscillator frequency is 1.6 MHz.

Figure 39. Bandgap Voltage vs. V_{CC}

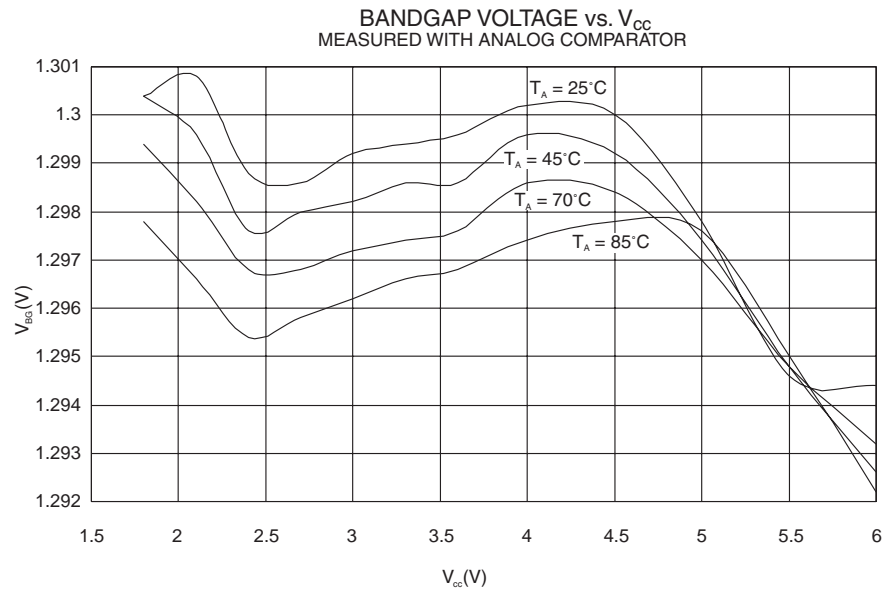
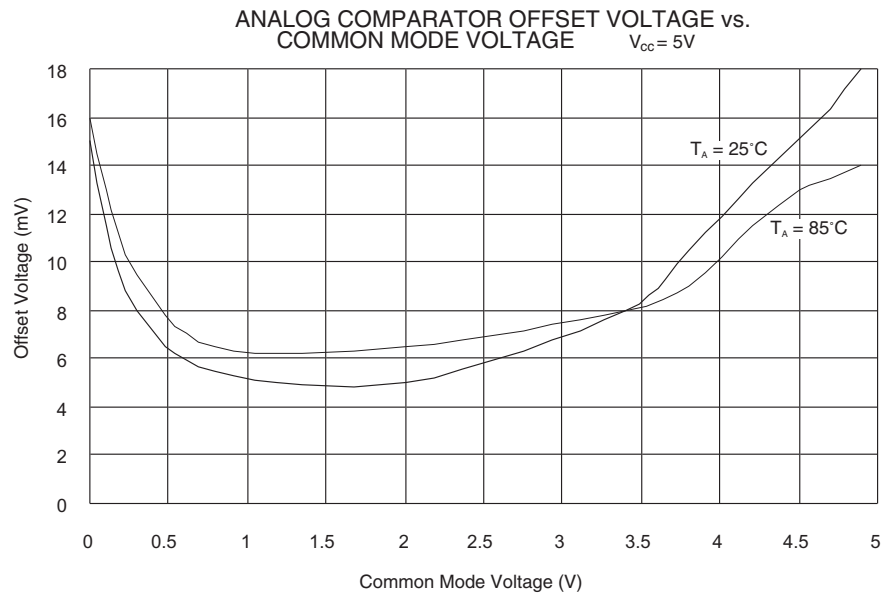

Figure 40. Analog Comparator Offset Voltage vs. Common Mode Voltage



Note: 1. Analog Comparator offset voltage is measured as absolute offset.

Figure 41. Analog Comparator Offset Voltage vs. Common Mode Voltage

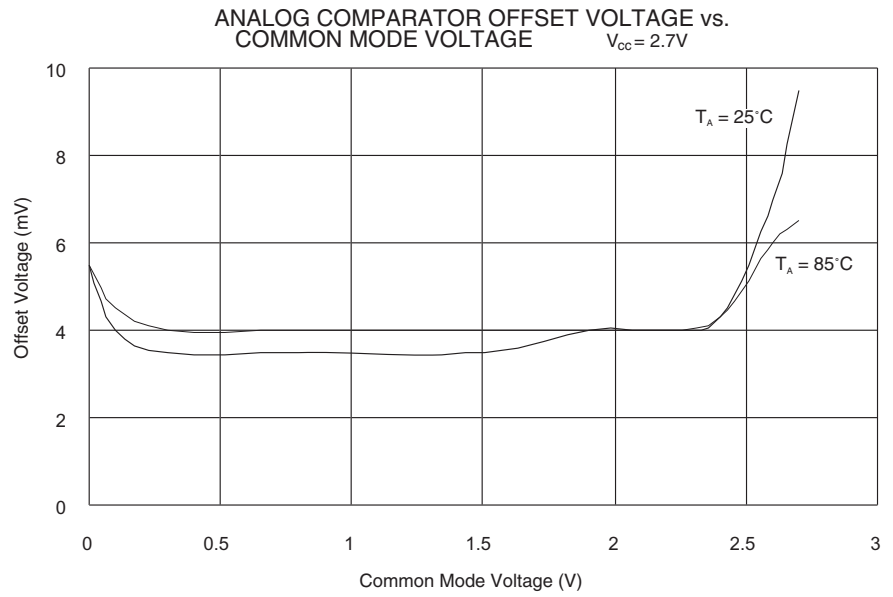

Figure 42. Analog Comparator Input Leakage Current

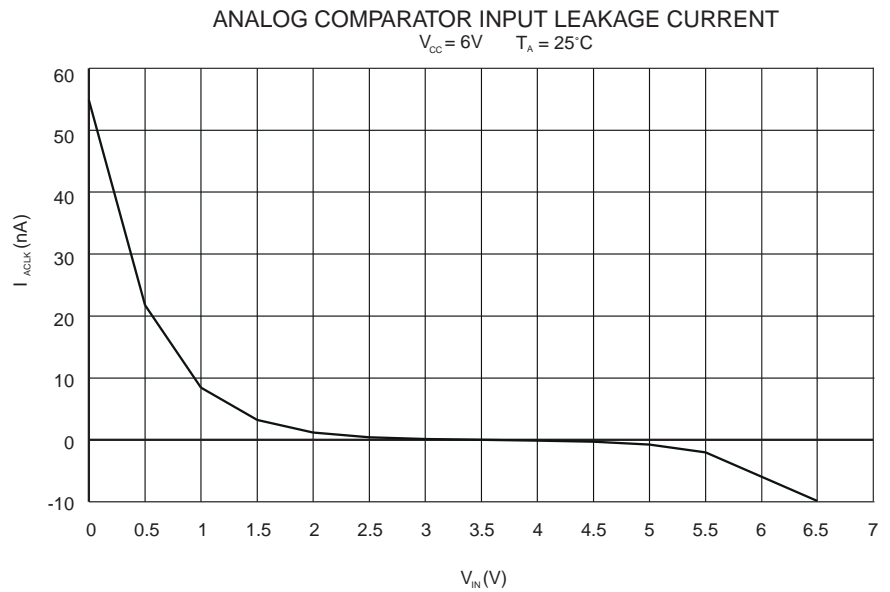
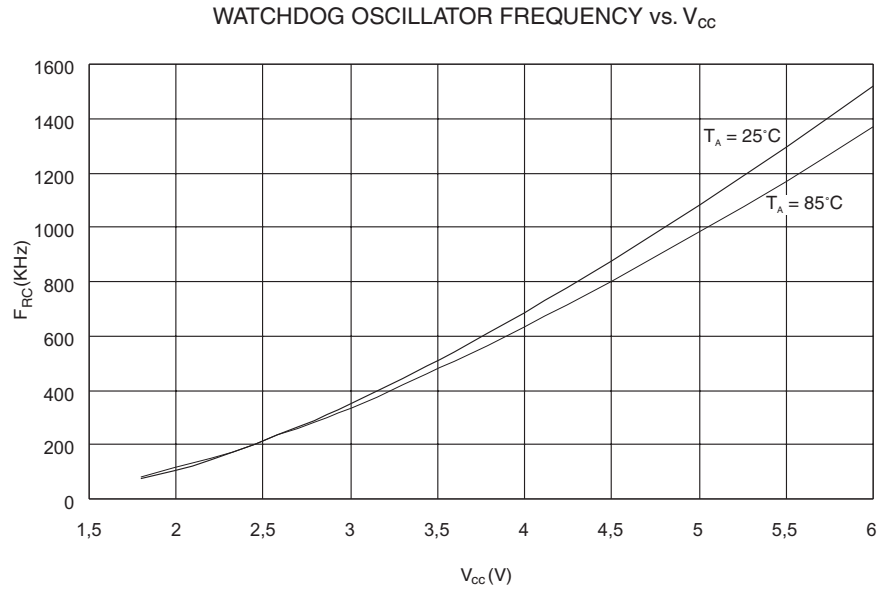

Figure 43. Watchdog Oscillator Frequency vs. V_{CC}



Note: 1. Sink and source capabilities of I/O ports are measured on one pin at a time.

Figure 44. Pull-up Resistor Current vs. Input Voltage

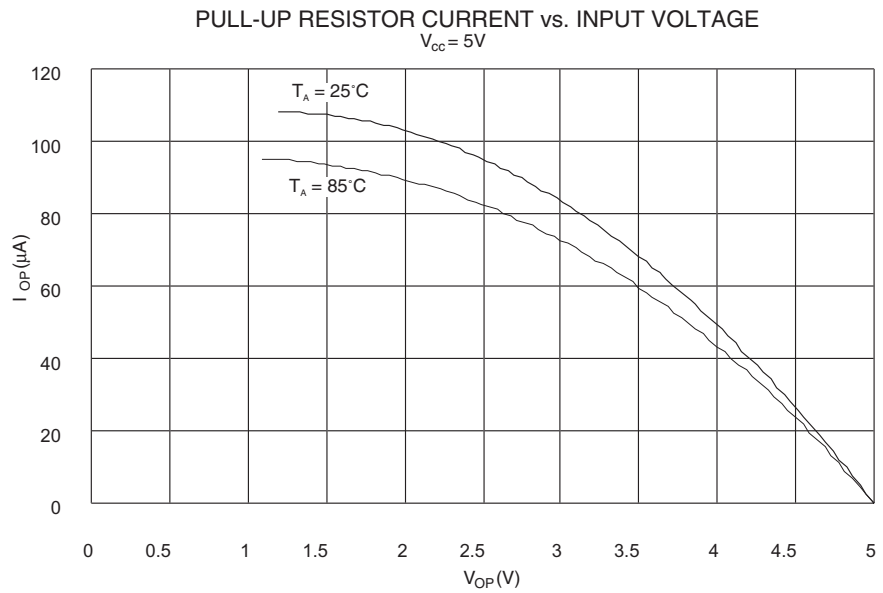

Figure 45. Pull-up Resistor Current vs. Input Voltage

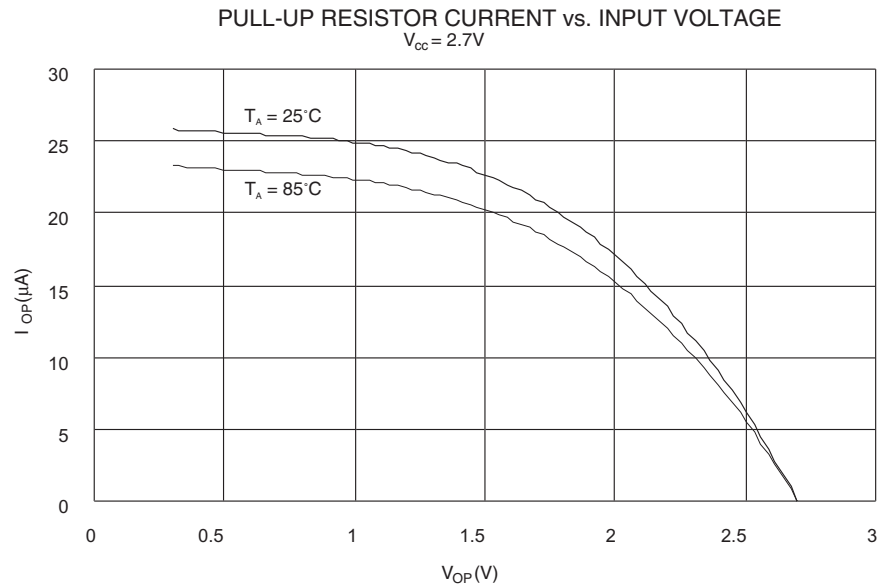

Figure 46. I/O Pin Sink Current vs. Output Voltage

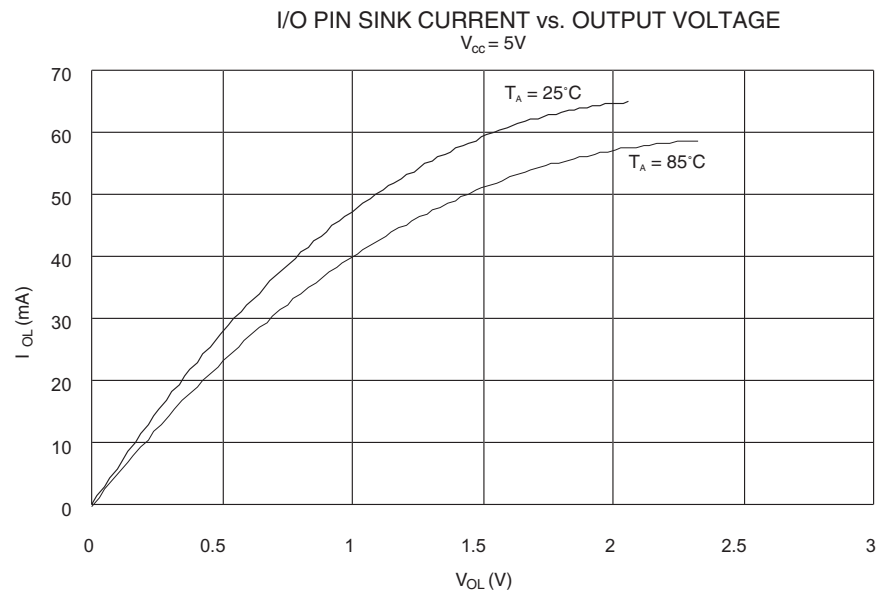

Figure 47. I/O Pin Source Current vs. Output Voltage

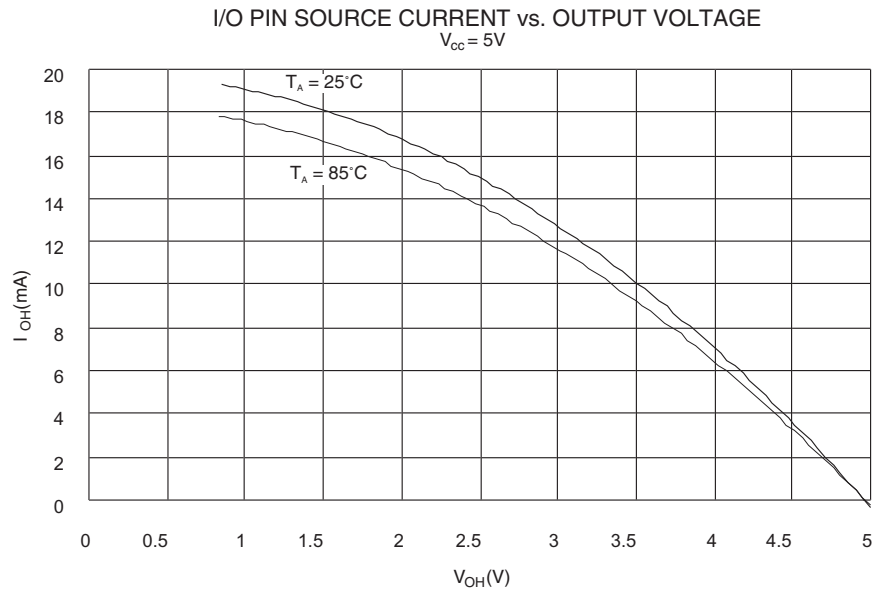

Figure 48. I/O Pin Sink Current vs. Output Voltage

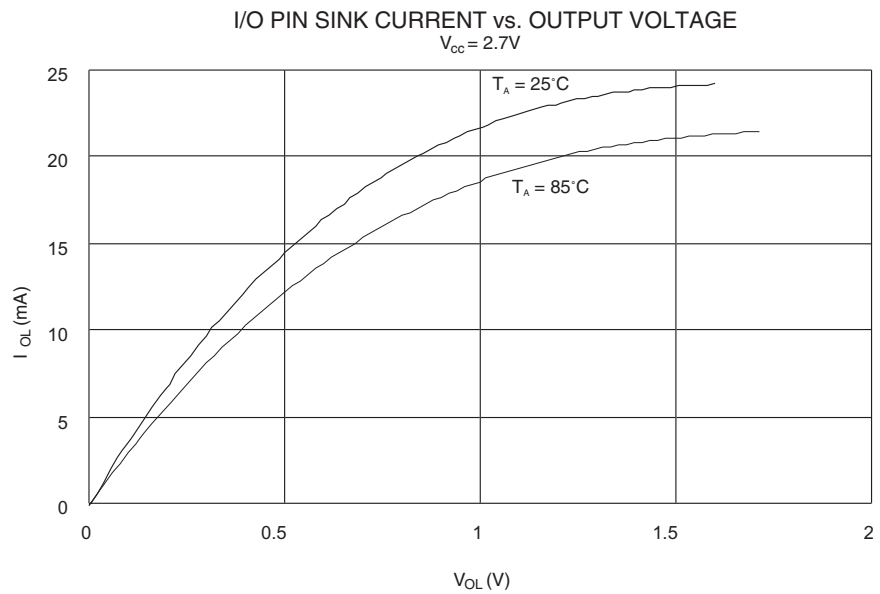

Figure 49. I/O Pin Source Current vs. Output Voltage

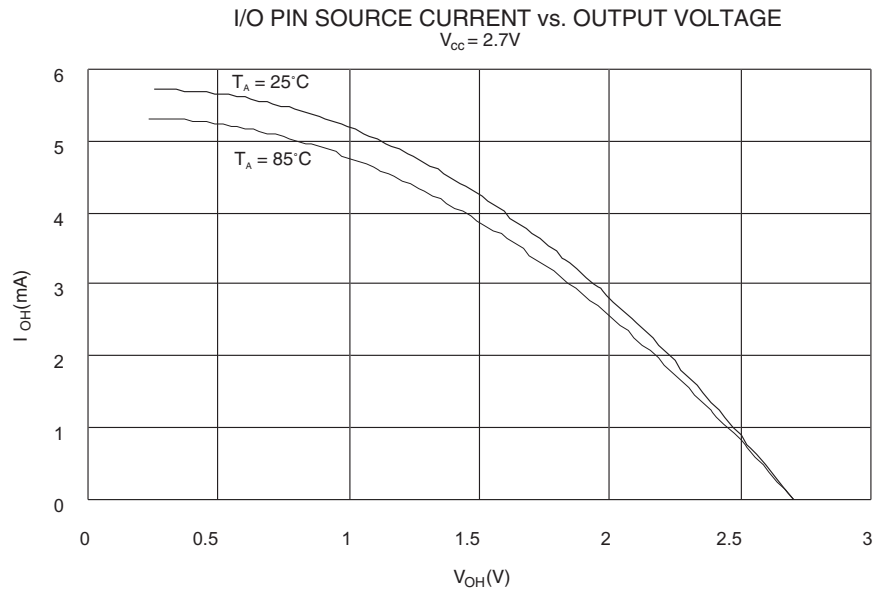

Figure 50. I/O Pin Input Threshold Voltage vs. V_{CC}

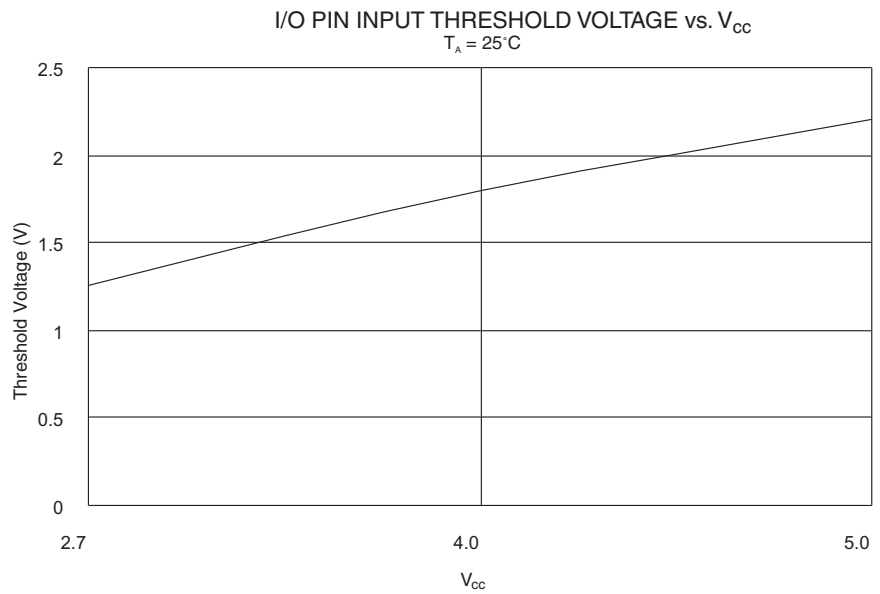
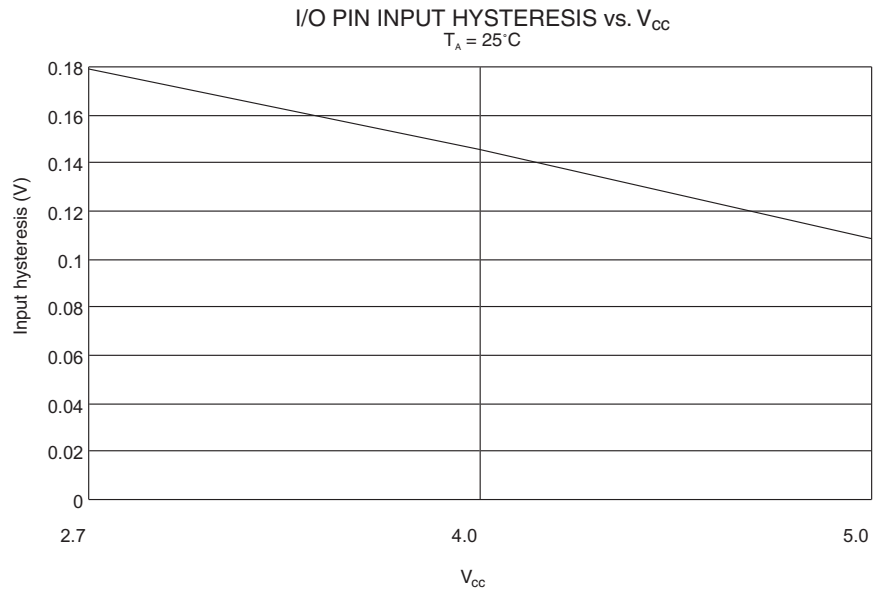

Figure 51. I/O Pin Input Hysteresis vs. V_{CC}



ATtiny15L Register Summary

Address	Name	Bit 7	Bit 6	Bit 5	Bit 4	Bit 3	Bit 2	Bit 1	Bit 0	Page
\$3F	SREG	I	T	H	S	V	N	Z	C	page 11
\$3E	Reserved									
\$3C	Reserved									
\$3B	GIMSK	-	INT0	PCIE	-	-	-	-	-	page 19
\$3A	GIFR	-	INTF0	PCIF	-	-	-	-	-	page 20
\$39	TIMSK	-	OCIE1A	-	-	-	TOIE1	TOIE0	-	page 20
\$38	TIFR	-	OCF1A	-	-	-	TOV1	TOV0	-	page 21
\$37	Reserved									
\$36	Reserved									
\$35	MCUCR	-	PUD	SE	SM1	SM0	-	ISC01	ISC00	page 22
\$34	MCUSR	-	-	-	-	WDRF	BORF	EXTRF	PORF	page 18
\$33	TCCR0	-	-	-	-	-	CS02	CS01	CS00	page 27
\$32	TCNT0	Timer/Counter0 (8-Bit)								page 28
\$31	OSCCAL	Oscillator Calibration Register								page 24
\$30	TCCR1	CTC1	PWM1	COM1A1	COM1A0	CS13	CS12	CS11	CS10	page 29
\$2F	TCNT1	Timer/Counter1 (8-Bit)								page 30
\$2E	OCR1A	Timer/Counter1 Output Compare Register A (8-Bit)								page 31
\$2D	OCR1B	Timer/Counter1 Output Compare Register B (8-Bit)								page 32
\$2C	SFIOR	-	-	-	-	-	FOC1A	PSR1	PSR0	page 26
\$2B	Reserved									
\$2A	Reserved									
\$29	Reserved									
\$28	Reserved									
\$27	Reserved									
\$26	Reserved									
\$25	Reserved									
\$24	Reserved									
\$23	Reserved									
\$22	Reserved									
\$21	WDTCSR	-	-	-	WDTOE	WDE	WDP2	WDP1	WDP0	page 34
\$20	Reserved									
\$1F	Reserved									
\$1E	EEAR	-	-	EEAR5	EEAR4	EEAR3	EEAR2	EEAR1	EEAR0	page 36
\$1D	EEDR	EEPROM Data Register (8-Bit)								page 36
\$1C	EECR	-	-	-	-	EERIE	EEMWE	EEWE	EERE	page 37
\$1B	Reserved									
\$1A	Reserved									
\$19	Reserved									
\$18	PORTB	-	-	-	PORTB4	PORTB3	PORTB2	PORTB1	PORTB0	page 51
\$17	DDRB	-	-	DDB5	DDB4	DDB3	DDB2	DDB1	DDB0	page 51
\$16	PINB	-	-	PINB5	PINB4	PINB3	PINB2	PINB1	PINB0	page 52
\$15	Reserved									
\$14	Reserved									
\$13	Reserved									
\$12	Reserved									
\$11	Reserved									
\$10	Reserved									
\$0F	Reserved									
\$0E	Reserved									
\$0D	Reserved									
\$0C	Reserved									
\$0B	Reserved									
\$0A	Reserved									
\$09	Reserved									
\$08	ACSR	ACD	ACBG	ACO	ACI	ACIE	-	ACIS1	ACIS0	page 39
\$07	ADMUX	REFS1	REFS0	ADLAR	-	-	MUX2	MUX1	MUX0	page 46
\$06	ADCSR	ADEN	ADSC	ADFR	ADIF	ADIE	ADPS2	ADPS1	ADPS0	page 47
\$05	ADCH	ADC Data Register High Byte								page 49
\$04	ADCL	ADC Data Register Low Byte								page 49
...	Reserved									
\$00	Reserved									

ATtiny15L Instruction Set Summary

Mnemonic	Operands	Description	Operation	Flags	# Clocks
ARITHMETIC AND LOGIC INSTRUCTIONS					
ADD	Rd, Rr	Add Two Registers	$Rd \leftarrow Rd + Rr$	Z,C,N,V,H	1
ADC	Rd, Rr	Add with Carry Two Registers	$Rd \leftarrow Rd + Rr + C$	Z,C,N,V,H	1
SUB	Rd, Rr	Subtract Two Registers	$Rd \leftarrow Rd - Rr$	Z,C,N,V,H	1
SUBI	Rd, K	Subtract Constant from Register	$Rd \leftarrow Rd - K$	Z,C,N,V,H	1
SBC	Rd, Rr	Subtract with Carry Two Registers	$Rd \leftarrow Rd - Rr - C$	Z,C,N,V,H	1
SBCI	Rd, K	Subtract with Carry Constant from Reg.	$Rd \leftarrow Rd - K - C$	Z,C,N,V,H	1
AND	Rd, Rr	Logical AND Registers	$Rd \leftarrow Rd \cdot Rr$	Z,N,V	1
ANDI	Rd, K	Logical AND Register and Constant	$Rd \leftarrow Rd \cdot K$	Z,N,V	1
OR	Rd, Rr	Logical OR Registers	$Rd \leftarrow Rd \vee Rr$	Z,N,V	1
ORI	Rd, K	Logical OR Register and Constant	$Rd \leftarrow Rd \vee K$	Z,N,V	1
EOR	Rd, Rr	Exclusive OR Registers	$Rd \leftarrow Rd \oplus Rr$	Z,N,V	1
COM	Rd	One's Complement	$Rd \leftarrow \text{NOT } Rd$	Z,C,N,V	1
NEG	Rd	Two's Complement	$Rd \leftarrow \text{NOT } Rd + 1$	Z,C,N,V,H	1
SBR	Rd, K	Set Bit(s) in Register	$Rd \leftarrow Rd \vee K$	Z,N,V	1
CBR	Rd, K	Clear Bit(s) in Register	$Rd \leftarrow Rd \cdot (\text{NOT } K)$	Z,N,V	1
INC	Rd	Increment	$Rd \leftarrow Rd + 1$	Z,N,V	1
DEC	Rd	Decrement	$Rd \leftarrow Rd - 1$	Z,N,V	1
TST	Rd	Test for Zero or Minus	$Rd \leftarrow Rd \cdot Rd$	Z,N,V	1
CLR	Rd	Clear Register	$Rd \leftarrow \text{NOT } Rd$	Z,N,V	1
SER	Rd	Set Register	$Rd \leftarrow \text{NOT } \text{NOT } Rd$	None	1
BRANCH INSTRUCTIONS					
RJMP	k	Relative Jump	$PC \leftarrow PC + k + 1$	None	2
RCALL	k	Relative Subroutine Call	$PC \leftarrow PC + k + 1$	None	3
RET		Subroutine Return	$PC \leftarrow \text{STACK}$	None	4
RETI		Interrupt Return	$PC \leftarrow \text{STACK}$	I	4
CPSE	Rd, Rr	Compare, Skip if Equal	if $(Rd = Rr)$ $PC \leftarrow PC + 2$ or 3	None	1/2
CP	Rd, Rr	Compare	$Rd - Rr$	Z,N,V,C,H	1
CPC	Rd, Rr	Compare with Carry	$Rd - Rr - C$	Z,N,V,C,H	1
CPI	Rd, K	Compare Register with Immediate	$Rd - K$	Z,N,V,C,H	1
SBRC	Rr, b	Skip if Bit in Register Cleared	if $(Rr(b) = 0)$ $PC \leftarrow PC + 2$ or 3	None	1/2
SBRS	Rr, b	Skip if Bit in Register is Set	if $(Rr(b) = 1)$ $PC \leftarrow PC + 2$ or 3	None	1/2
SBIC	P, b	Skip if Bit in I/O Register Cleared	if $(P(b) = 0)$ $PC \leftarrow PC + 2$ or 3	None	1/2
SBIS	P, b	Skip if Bit in I/O Register is Set	if $(P(b) = 1)$ $PC \leftarrow PC + 2$ or 3	None	1/2
BRBS	s, k	Branch if Status Flag Set	if $(SREG(s) = 1)$ then $PC \leftarrow PC + k + 1$	None	1/2
BRBC	s, k	Branch if Status Flag Cleared	if $(SREG(s) = 0)$ then $PC \leftarrow PC + k + 1$	None	1/2
BREQ	k	Branch if Equal	if $(Z = 1)$ then $PC \leftarrow PC + k + 1$	None	1/2
BRNE	k	Branch if Not Equal	if $(Z = 0)$ then $PC \leftarrow PC + k + 1$	None	1/2
BRCS	k	Branch if Carry Set	if $(C = 1)$ then $PC \leftarrow PC + k + 1$	None	1/2
BRCC	k	Branch if Carry Cleared	if $(C = 0)$ then $PC \leftarrow PC + k + 1$	None	1/2
BRSH	k	Branch if Same or Higher	if $(C = 0)$ then $PC \leftarrow PC + k + 1$	None	1/2
BRLO	k	Branch if Lower	if $(C = 1)$ then $PC \leftarrow PC + k + 1$	None	1/2
BRMI	k	Branch if Minus	if $(N = 1)$ then $PC \leftarrow PC + k + 1$	None	1/2
BRPL	k	Branch if Plus	if $(N = 0)$ then $PC \leftarrow PC + k + 1$	None	1/2
BRGE	k	Branch if Greater or Equal, Signed	if $(N \oplus V = 0)$ then $PC \leftarrow PC + k + 1$	None	1/2
BRLT	k	Branch if Less Than Zero, Signed	if $(N \oplus V = 1)$ then $PC \leftarrow PC + k + 1$	None	1/2
BRHS	k	Branch if Half-carry Flag Set	if $(H = 1)$ then $PC \leftarrow PC + k + 1$	None	1/2
BRHC	k	Branch if Half-carry Flag Cleared	if $(H = 0)$ then $PC \leftarrow PC + k + 1$	None	1/2
BRTS	k	Branch if T-flag Set	if $(T = 1)$ then $PC \leftarrow PC + k + 1$	None	1/2
BRTC	k	Branch if T-flag Cleared	if $(T = 0)$ then $PC \leftarrow PC + k + 1$	None	1/2
BRVS	k	Branch if Overflow Flag is Set	if $(V = 1)$ then $PC \leftarrow PC + k + 1$	None	1/2
BRVC	k	Branch if Overflow Flag is Cleared	if $(V = 0)$ then $PC \leftarrow PC + k + 1$	None	1/2
BRIE	k	Branch if Interrupt Enabled	if $(I = 1)$ then $PC \leftarrow PC + k + 1$	None	1/2
BRID	k	Branch if Interrupt Disabled	if $(I = 0)$ then $PC \leftarrow PC + k + 1$	None	1/2
DATA TRANSFER INSTRUCTIONS					
LD	Rd, Z	Load Register Indirect	$Rd \leftarrow (Z)$	None	2
ST	Z, Rr	Store Register Indirect	$(Z) \leftarrow Rr$	None	2
MOV	Rd, Rr	Move between Registers	$Rd \leftarrow Rr$	None	1
LDI	Rd, K	Load Immediate	$Rd \leftarrow K$	None	1
IN	Rd, P	In Port	$Rd \leftarrow P$	None	1
OUT	P, Rr	Out Port	$P \leftarrow Rr$	None	1
LPM		Load Program Memory	$R0 \leftarrow (Z)$	None	3
BIT AND BIT-TEST INSTRUCTIONS					
SBI	P, b	Set Bit in I/O Register	$I/O(P,b) \leftarrow 1$	None	2

ATtiny15L Instruction Set Summary (Continued)

Mnemonic	Operands	Description	Operation	Flags	# Clocks
CBI	P, b	Clear Bit in I/O Register	I/O(P,b) ← 0	None	2
LSL	Rd	Logical Shift Left	Rd(n+1) ← Rd(n), Rd(0) ← 0	Z,C,N,V	1
LSR	Rd	Logical Shift Right	Rd(n) ← Rd(n+1), Rd(7) ← 0	Z,C,N,V	1
ROL	Rd	Rotate Left through Carry	Rd(0) ← C, Rd(n+1) ← Rd(n), C ← Rd(7)	Z,C,N,V	1
ROR	Rd	Rotate Right through Carry	Rd(7) ← C, Rd(n) ← Rd(n+1), C ← Rd(0)	Z,C,N,V	1
ASR	Rd	Arithmetic Shift Right	Rd(n) ← Rd(n+1), n = 0..6	Z,C,N,V	1
SWAP	Rd	Swap Nibbles	Rd(3..0) ← Rd(7..4), Rd(7..4) ← Rd(3..0)	None	1
BSET	s	Flag Set	SREG(s) ← 1	SREG(s)	1
BCLR	s	Flag Clear	SREG(s) ← 0	SREG(s)	1
BST	Rr, b	Bit Store from Register to T	T ← Rr(b)	T	1
BLD	Rd, b	Bit Load from T to Register	Rd(b) ← T	None	1
SEC		Set Carry	C ← 1	C	1
CLC		Clear Carry	C ← 0	C	1
SEN		Set Negative Flag	N ← 1	N	1
CLN		Clear Negative Flag	N ← 0	N	1
SEZ		Set Zero Flag	Z ← 1	Z	1
CLZ		Clear Zero Flag	Z ← 0	Z	1
SEI		Global Interrupt Enable	I ← 1	I	1
CLI		Global Interrupt Disable	I ← 0	I	1
SES		Set Signed Test Flag	S ← 1	S	1
CLS		Clear Signed Test Flag	S ← 0	S	1
SEV		Set Two's Complement Overflow	V ← 1	V	1
CLV		Clear Two's Complement Overflow	V ← 0	V	1
SET		Set T in SREG	T ← 1	T	1
CLT		Clear T in SREG	T ← 0	T	1
SEH		Set Half-carry Flag in SREG	H ← 1	H	1
CLH		Clear Half-carry Flag in SREG	H ← 0	H	1
NOP		No Operation		None	1
SLEEP		Sleep	(see specific descr. for Sleep function)	None	1
WDR		Watchdog Reset	(see specific descr. for WDR/timer)	None	1

Ordering Information

Power Supply	Speed (MHz)	Ordering Code	Package	Operation Range
2.7 - 5.5V	1.6	ATtiny15L-1PC	8P3	Commercial (0°C to 70°C)
		ATtiny15L-1PU ⁽¹⁾	8P3	
		ATtiny15L-1SC	8S2	
		ATtiny15L-1SU ⁽¹⁾	8S2	
		ATtiny15L-1PI	8P3	Industrial (-40°C to 85°C)
		ATtiny15L-1PU ⁽¹⁾	8P3	
		ATtiny15L-1SI	8S2	
		ATtiny15L-1SU ⁽¹⁾	8S2	

Note: 1. Pb-free packaging, complies to the European Directive for Restriction of Hazardous Substances (RoHS directive). Also Halide free and fully Green.

Package Type	
8P3	8-lead, 0.300" Wide, Plastic Dual Inline Package (PDIP)
8S2	8-lead, 0.200" Wide, Plastic Gull Wing Small Outline (EIAJ SOIC)

Packaging Information

8P3

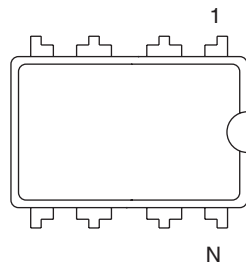

Top View

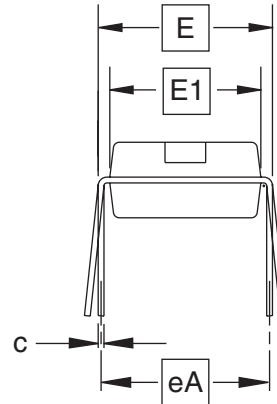

End View

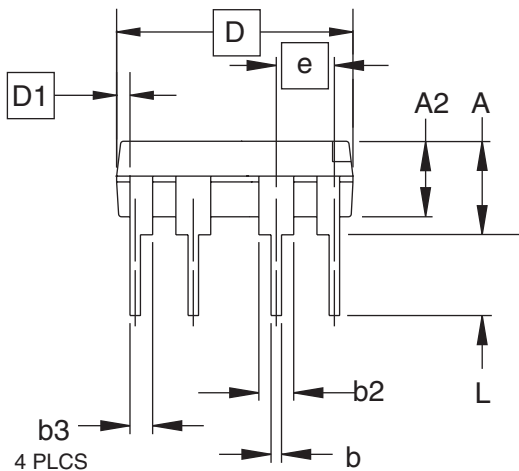

Side View

COMMON DIMENSIONS
(Unit of Measure = inches)

SYMBOL	MIN	NOM	MAX	NOTE
A			0.210	2
A2	0.115	0.130	0.195	
b	0.014	0.018	0.022	5
b2	0.045	0.060	0.070	6
b3	0.030	0.039	0.045	6
c	0.008	0.010	0.014	
D	0.355	0.365	0.400	3
D1	0.005			3
E	0.300	0.310	0.325	4
E1	0.240	0.250	0.280	3
e	0.100 BSC			
eA	0.300 BSC			4
L	0.115	0.130	0.150	2

- Notes:
1. This drawing is for general information only; refer to JEDEC Drawing MS-001, Variation BA for additional information.
 2. Dimensions A and L are measured with the package seated in JEDEC seating plane Gauge GS-3.
 3. D, D1 and E1 dimensions do not include mold Flash or protrusions. Mold Flash or protrusions shall not exceed 0.010 inch.
 4. E and eA measured with the leads constrained to be perpendicular to datum.
 5. Pointed or rounded lead tips are preferred to ease insertion.
 6. b2 and b3 maximum dimensions do not include Dambar protrusions. Dambar protrusions shall not exceed 0.010 (0.25 mm).

01/09/02



2325 Orchard Parkway
San Jose, CA 95131

TITLE
8P3, 8-lead, 0.300" Wide Body, Plastic Dual
In-line Package (PDIP)

DRAWING NO.	REV.
8P3	B

8S2

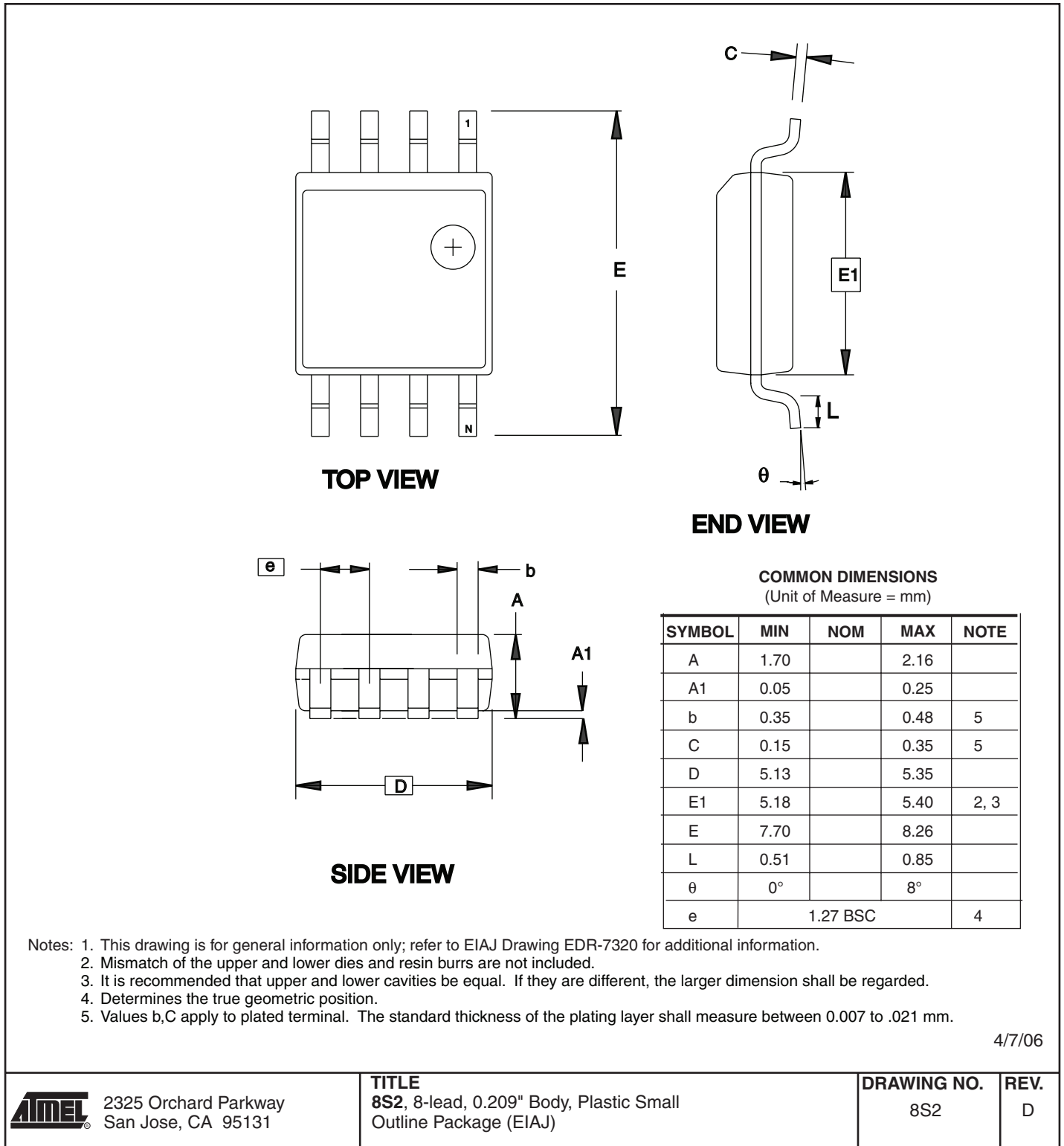

Datasheet revision history

Rev H - 09/07

1. Updated "Ordering Information" on page 78.

Rev G - 06/07

1. "Not recommended for new design".

Rev F - 06/05

1. Updated V_{BOT} in Table 4 on page 14.
2. Added "Unconnected Pins" on page 51.
3. Updated "Packaging Information" on page 80.

Table of Contents	Features.....	1
	Pin Configuration.....	1
	Description.....	2
	Block Diagram	3
	Pin Descriptions.....	4
	Internal Oscillators	4
	ATtiny15L Architectural Overview.....	5
	The General Purpose Register File	6
	The ALU – Arithmetic Logic Unit.....	6
	The Flash Program Memory	6
	The Program and Data Addressing Modes	7
	Subroutine and Interrupt Hardware Stack	9
	The EEPROM Data Memory	9
	I/O Memory	10
	Reset and Interrupt Handling.....	12
	Internal Voltage Reference.....	18
	Interrupt Handling	19
	Sleep Modes.....	23
	Tuneable Internal RC Oscillator.....	24
	Internal PLL for Fast Peripheral Clock Generation	24
	Timer/Counters	25
	The Timer/Counter0 Prescaler	25
	The Timer/Counter1 Prescaler	25
	The Special Function IO Register – SFIOR.....	26
	The 8-bit Timer/Counter0.....	26
	The 8-bit Timer/Counter1.....	28
	The Watchdog Timer	34
	EEPROM Read/Write Access.....	36
	Preventing EEPROM Corruption	38
	The Analog Comparator.....	39
	The Analog-to-Digital Converter, Analog Multiplexer, and Gain Stages.....	41
	Features.....	41
	Operation	42
	Prescaling and Conversion Timing	43
	ADC Noise Canceler Function.....	46
	ADC Noise-canceling Techniques.....	50
	ADC Characteristics	50



<i>I/O Port B</i>	51
<i>Memory Programming</i>	54
Program and Data Memory Lock Bits	54
Fuse Bits	54
Signature Bytes	54
Calibration Byte	55
Programming the Flash	55
High-voltage Serial Programming	55
High-voltage Serial Programming Algorithm	56
High-voltage Serial Programming Characteristics	59
Low-voltage Serial Downloading	59
Low-voltage Serial Programming Characteristics	63
<i>Electrical Characteristics</i>	64
Absolute Maximum Ratings	64
DC Characteristics	64
<i>Typical Characteristics</i>	66
<i>ATtiny15L Register Summary</i>	75
<i>ATtiny15L Instruction Set Summary</i>	76
<i>Ordering Information</i>	78
<i>Packaging Information</i>	79
8P3	79
8S2	80
<i>Datasheet revision history</i>	81
Rev H - 09/07	81
Rev G - 06/07	81
Rev F - 06/05	81
<i>Table of Contents</i>	<i>i</i>



Headquarters

Atmel Corporation
2325 Orchard Parkway
San Jose, CA 95131
USA
Tel: 1(408) 441-0311
Fax: 1(408) 487-2600

International

Atmel Asia
Room 1219
Chinachem Golden Plaza
77 Mody Road Tsimshatsui
East Kowloon
Hong Kong
Tel: (852) 2721-9778
Fax: (852) 2722-1369

Atmel Europe
Le Krebs
8, Rue Jean-Pierre Timbaud
BP 309
78054 Saint-Quentin-en-
Yvelines Cedex
France
Tel: (33) 1-30-60-70-00
Fax: (33) 1-30-60-71-11

Atmel Japan
9F, Tonetsu Shinkawa Bldg.
1-24-8 Shinkawa
Chuo-ku, Tokyo 104-0033
Japan
Tel: (81) 3-3523-3551
Fax: (81) 3-3523-7581

Product Contact

Web Site
www.atmel.com

Technical Support
avr@atmel.com

Sales Contact
www.atmel.com/contacts

Literature Requests
www.atmel.com/literature

Disclaimer: The information in this document is provided in connection with Atmel products. No license, express or implied, by estoppel or otherwise, to any intellectual property right is granted by this document or in connection with the sale of Atmel products. **EXCEPT AS SET FORTH IN ATMEL'S TERMS AND CONDITIONS OF SALE LOCATED ON ATMEL'S WEB SITE, ATMEL ASSUMES NO LIABILITY WHATSOEVER AND DISCLAIMS ANY EXPRESS, IMPLIED OR STATUTORY WARRANTY RELATING TO ITS PRODUCTS INCLUDING, BUT NOT LIMITED TO, THE IMPLIED WARRANTY OF MERCHANTABILITY, FITNESS FOR A PARTICULAR PURPOSE, OR NON-INFRINGEMENT. IN NO EVENT SHALL ATMEL BE LIABLE FOR ANY DIRECT, INDIRECT, CONSEQUENTIAL, PUNITIVE, SPECIAL OR INCIDENTAL DAMAGES (INCLUDING, WITHOUT LIMITATION, DAMAGES FOR LOSS OF PROFITS, BUSINESS INTERRUPTION, OR LOSS OF INFORMATION) ARISING OUT OF THE USE OR INABILITY TO USE THIS DOCUMENT, EVEN IF ATMEL HAS BEEN ADVISED OF THE POSSIBILITY OF SUCH DAMAGES.** Atmel makes no representations or warranties with respect to the accuracy or completeness of the contents of this document and reserves the right to make changes to specifications and product descriptions at any time without notice. Atmel does not make any commitment to update the information contained herein. Unless specifically provided otherwise, Atmel products are not suitable for, and shall not be used in, automotive applications. Atmel's products are not intended, authorized, or warranted for use as components in applications intended to support or sustain life.

© Atmel Corporation 2005. All rights reserved. Atmel®, logo and combinations thereof, AVR® and others are the registered trademarks of Atmel Corporation or its subsidiaries. Other terms and product names may be trademarks of others.