

SPECIFICATIONS – Model Number CMX69273P

Frequency	698 MHz - 960MHz 1710MHz - 2700 MHz
Gain (dBi)	4.1 (typical), 4.5 (max) @ 700 Band 4.2 (typical), 4.2 (max) @ 800 Band 4.1 (typical), 4.2 (max) @ 900 Band 3.3 (typical), 3.5 (max) @ 1800 Band 2.9 (typical), 3.3 (max) @ 1900 Band 2.6 (typical), 2.9 (max) @ 2100 Band 2.8 (typical), 3.3 (max) @ 2300 Band 3.1 (typical), 3.3 (max) @ 2600 Band
Port to Port Isolation	<-16dB @ 698-960MHz <-16dB @ 1710-2700MHz
PIM, 3rd order, 2X20W	< -150dBc
Nominal Impedance	50 Ohms
Polarization	Linear, Omnidirectional
VSWR	1.7:1 max across the bands
Power Input (Max.)	50 Watts (ambient temp of 25°C)
Operating Temperature Range	-40°C +85°C
Cable	Semi flexible 402 cable
Connector	Model Specific
Exposed Cable length, Lc	Model Specific
Weight	Approximately 0.60 kg (1.32 lbs.)
Mounting	Ceiling mount (drywall or tile flush mount)
Radome	PC/ABS, UL94 V-0 (White)
Dimensions, mm	Ø250mm (W) x 49mm (H)
RoHs	Compliant



Patent Pending

Please read all instructions carefully before attempting to install and use this product.

SAFETY

The CMX69273P and all associated equipment should be installed in accordance with all applicable local and national electrical code guidelines to ensure safe operation.

APPLICATION

The CMX69273P antenna is designed and optimized for LTE MIMO system requirements covering a wide range of operating frequency. The covered frequency range includes the band of 700/ 850/ 900/ 1800/ 1900/2100/2300/2600. The antenna offers low cross correlation between the two radiating elements suitable for MIMO applications.

LOCATION

For best results, mount the antenna near the center of the coverage area. A line-of-sight path between the antenna and active floor locations generally works best. Although microwave signals penetrate cubical dividers and interior walls with little attenuation, reinforced block walls, banks of metal cabinets, or steel shelving may attenuate signals or cause multipath, a condition where reflected signals interfere with the primary signal path. Avoid mounting next to a column or vertical support that could create a “shadow zone” of reduced coverage to one portion of the room.

PRECAUTION

For best PIM results:

1. Make sure the connectors are clean and free from any metal flakes/dirt & tighten the connectors using torque wrench according to connector torque specification below.

Mini-Din 4.1-9.5	N-Type
90 inch/LBS (10.16Nm)	25 inch/LBS (2.82Nm)

2. Avoid extreme bending to the cable.
3. During installation of the antenna, both cables should not be crossing one another.
4. Do not remove the dust cap from connectors when not in use.

STANDARD MOUNTING

A threaded post on the back of the antenna and a supplied mounting nut are the primary mounting method when access is available to both sides of the mounting surface, such as a suspended ceiling tile. Mark the desired mounting location on the tile and cut a Ø40mm (1.57”) hole for threaded post. Feed the cables through the hole and secure the antenna with the mounting nut. (See figure 1).

Figure 1

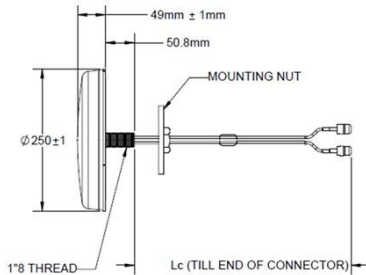

Warranty and Liability

Laird warrants to the original purchaser that antenna products will remain free from defects in materials and workmanship for a period of five (5) years from the purchase date. If any such defect is discovered within the warranty period, Laird will at its sole option, repair or replace the Product free of charge upon its return to the factory. This warranty applies only if the Product is used in a normal fashion, and is void if the Product is abused, disassembled, tampered with, used unreasonably, or fails as a result of normal wear. Furthermore, this warranty applies only to defects, which occur where the proper Product is selected as recommended by Laird and is used in the fashion recommended by Laird for the defective Product. THIS WARRANTY IS IN LIEU OF ALL OTHER WARRANTIES, EXPRESSED OR IMPLIED, AND IS LIMITED TO A PERIOD OF FIVE (5) YEARS FROM THE DATE OF ORIGINAL PURCHASE. LAIRD IS NOT LIABLE FOR INCIDENTAL OR CONSEQUENTIAL DAMAGES OF ANY KIND. ANY WARRANTY EXTENDED HEREIN SHALL BE LIMITED TO THE PRICE PAID TO LAIRD FOR THE DEFECTIVE PRODUCT. WHERE STATE OR LOCAL LAW GOVERNS THE PERIOD OF WARRANTY, SUCH PERIOD SHALL CONTROL.

Americas: +1.847 839.6907
IAS-AmericasEastSales@lairdtech.com

Europe: +44.1628.858941
IAS-EUSales@lairdtech.com

Asia: +86.21.5855.0827.127
IAS-AsiaSales@lairdtech.com

TWIST & LOCK MOUNTING (drywall/sheetrock)

Part Number: HKIT-CMx-003

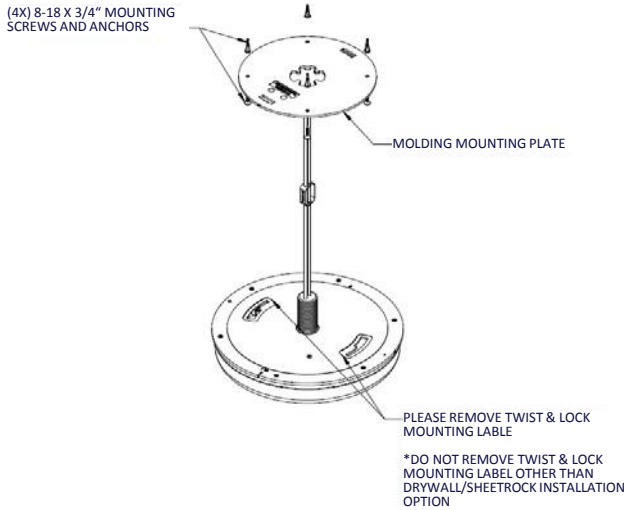

ABOVE CEILING MOUNTING

Mounting Bracket Part Number: HKIT-CMx-001

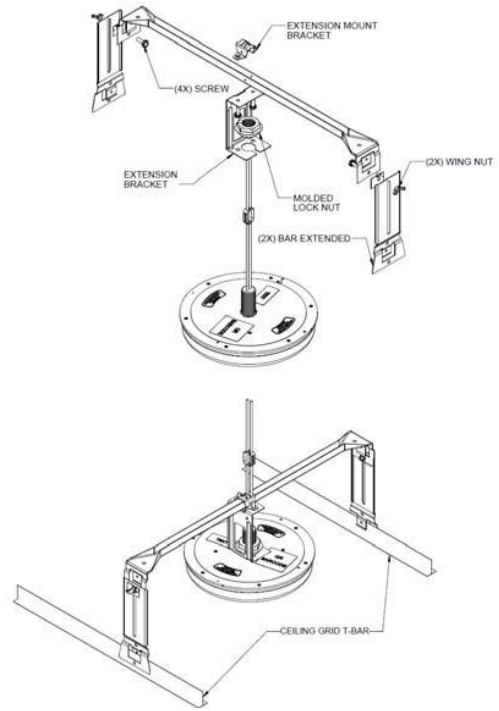

ABOVE CEILING MOUNTING

PE Foam Standoff (Double Sided Adhesive)
Part Number: HKIT-CMx-004

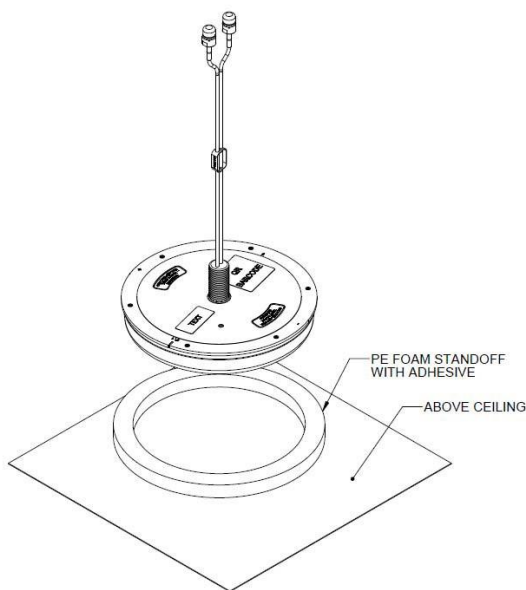

HARD CEILING MOUNTING

Part Number: HKIT-CMx-002

1. Top Mounting

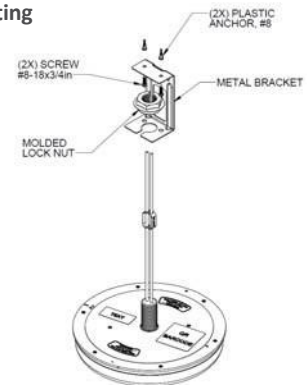

2. Side Mounting

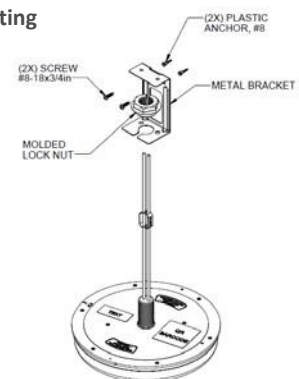

NOTE: The optional mounting kits are NOT INCLUDED with the antenna; it needs to be purchased separately.

ANGLE MARKING

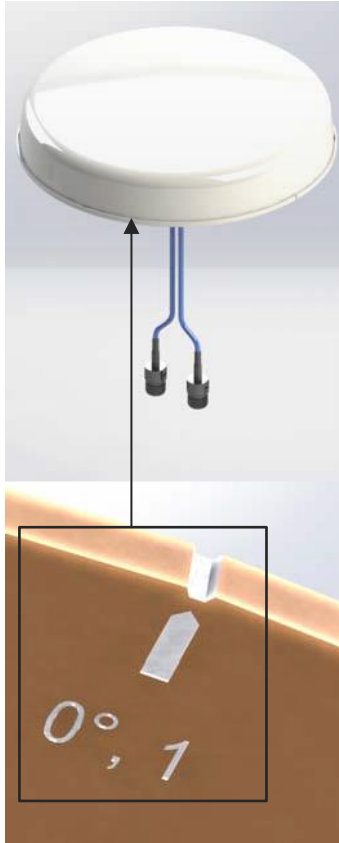

Δ0 deg marking below the antenna base plate indicates 0 deg angle of azimuth plane radiation pattern.

1, 2, marking below the antenna base plate indicates the radiator number in the antenna.

QR CODES

There is a unique QR Codes placed on the back of each antenna, so system managers can simply scan the code with a smartphone and instantly see all of the needed performance data. The solution provides fast, accurate data and allows customers to instantly track even more information than they could previously review.

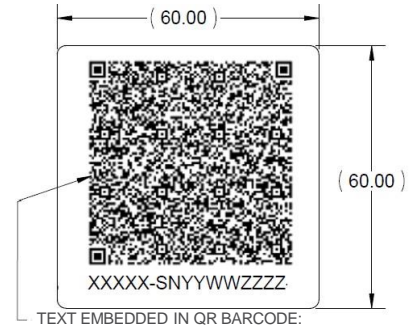

CMX69273P-XXXX-SNYYWWZZZZ,

PORT 1 VSWR: V@700MHz, V@850MHz, V@900MHz, V@1500MHz, V@1800MHz, V@1900MHz, V@2100MHz, V@2300MHz, V@2600MHz;

PORT 2 VSWR: V@700MHz, V@850MHz, V@900MHz, V@1500MHz, V@1800MHz, V@1900MHz, V@2100MHz, V@2300MHz, V@2600MHz;

LOW PIM PORT 1 HIGH BAND: -LdBc, LOW BAND: -LdBc;

LOW PIM PORT 2 HIGH BAND: -LdBc, LOW BAND: -LdBc;

QR CODE: CMX69273P-XXXX-SNYYWWZZZZ = SERIAL NUMBERING

V = VALUE OF VSWR @ FREQUENCY BANDS (700MHz, 850MHz, 900MHz, 1500MHz, 1800MHz, 1900MHz, 2100MHz, 2300MHz & 2600MHz) FOR PORT1, PORT 2.

L = LOW PIM VALUE AT LOW BAND & HIGH BAND FOR PORT 1, PORT 2.