

# Customer Information Sheet

DRAWING No.: M80-470XXXX

SHEET 2 OF 2

IF IN DOUBT - ASK

©

NOT TO SCALE

THIRD ANGLE PROJECTION

ALL DIMENSIONS IN mm

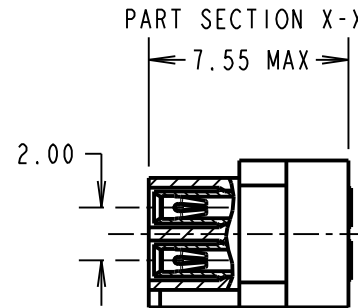
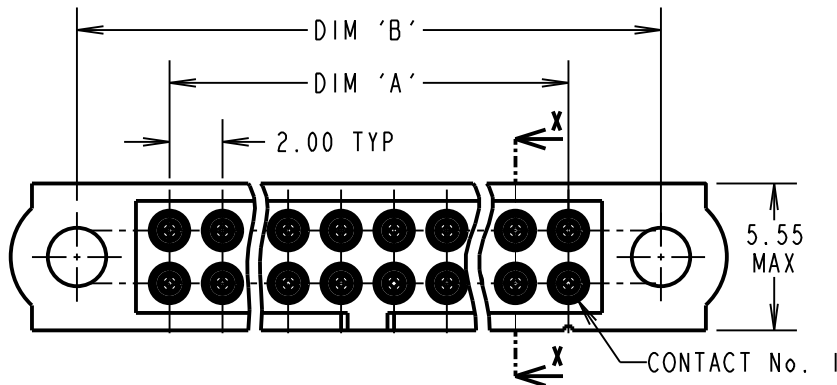

**SPECIFICATIONS:**

**MATERIAL:**

MOULDING = GLASS-FILLED PPS, UL94V-0, BLACK

CONTACT CLIP = BERYLLIUM COPPER

CONTACT SHELL = BRASS

**FINISH:**

05 = 0.3µ GOLD CLIP, 0.25-0.3µ GOLD SHELL

42 = 0.3µ GOLD CLIP,

3.5-5.0µ 100% TIN OVER NICKEL SHELL

**ELECTRICAL:**

CURRENT RATING AT 25°C = 3.0A MAX

CURRENT RATING AT 85°C = 2.2A MAX

WORKING VOLTAGE = 120V AC/DC

VOLTAGE PROOF = 360V AC/DC

CONTACT RESISTANCE = 25 mΩ MAX

INSULATION RESISTANCE = 100 MΩ MIN

**MECHANICAL:**

DURABILITY = 500 OPERATIONS

INSERTION FORCE (∅0.5mm GAUGE) = 2.8N MAX

WITHDRAWAL FORCE (∅0.5mm GAUGE) = 0.2N MIN

**ENVIRONMENTAL:**

TEMPERATURE RANGE = -55°C TO +125°C

**PACKING:**

LOOSE

FOR COMPLETE SPECIFICATION, SEE

COMPONENT SPECIFICATION C005XX

(LATEST ISSUE)

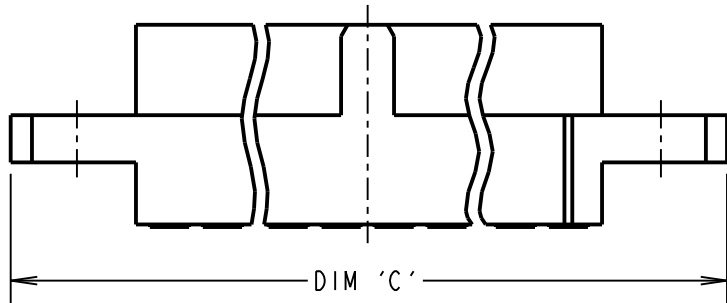

**NOTES:**

- CONNECTOR IS SUPPLIED WITH CONTACTS LOOSE.
- FOR EXTRA CONTACTS, USE PART NUMBER M80-0110005 FOR M80-470XX05 AND M80-0110001 FOR M80-470XX42.
- RECOMMENDED WIRE TYPE = BS 3G 210 TYPE A, PTFE INSULATED 22 AWG. MAX INSULATION DIAMETER = ∅1.10mm, STRIP WIRE BY 2.00mm.
- RECOMMENDED HAND CRIMP TOOL = M22520/2-01 WITH POSITIONER T5747. REFER TO TOOLING INSTRUCTION SHEET IS-01 FOR COMPLETE CRIMPING INSTRUCTIONS.
- CONTACT INSERTION AND EXTRACTION TOOL = Z80-280. REFER TO TOOLING INSTRUCTION SHEET IS-25 FOR ASSEMBLY INSTRUCTIONS.

DIMENSION	CALCULATION
DIM 'A'	TOTAL No. OF CONTACTS - 2
DIM 'B'	TOTAL No. OF CONTACTS + 5
DIM 'C'	TOTAL No. OF CONTACTS + 10
EXAMPLE: CONNECTOR WITH 20 CONTACTS, GOLD CLIP AND 100% TIN OVER NICKEL SHELL, M80-4702042	
DIM 'A' = 18.00mm, DIM 'B' = 25.00mm, DIM 'C' = 30.00mm	

**ORDER CODE:**

**M80-470XXXX**

TOTAL No. OF CONTACTS  
04 TO 50  
(EVEN NUMBERS ONLY)

**FINISH CODE**

05 - GOLD CLIP, GOLD SHELL

42 - GOLD CLIP, 100% TIN OVER NICKEL SHELL

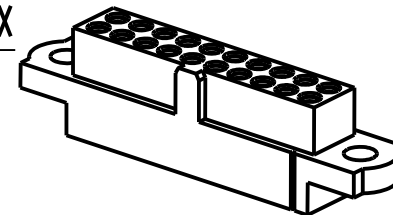

SB	2	21.07.11	11376
NAME	ISS.	DATE	C/NOTE
APPROVED: S.BENNETT			
CHECKED: M.G.PLESTED			
DRAWN: W. J. BOURNE			
CUSTOMER REF.:			
ASSEMBLY DRG:			

**HARWIN**

HARWIN USA  
TEL: 603 893 5376  
FAX: 603 893 5396  
mis@harwin.com

HARWIN Europe (UK)  
TEL: 023 9231 4545  
FAX: 023 9231 4590  
mis@harwin.co.uk

HARWIN Asia  
TEL: +65 6 779 4909  
FAX: +65 6 779 3868  
mis@harwin.com.sg

THIS DRAWING AND ANY INFORMATION OR DESCRIPTIVE MATTER SET OUT HEREON ARE CONFIDENTIAL AND COPYRIGHT PROPERTY OF THE HARWIN GROUP AND MUST NOT BE DISCLOSED, LOANED, COPIED OR USED FOR MANUFACTURING, TENDERING OR FOR ANY OTHER PURPOSE WITHOUT THEIR WRITTEN PERMISSION.

**TOLERANCES**  
X. = ±1mm  
X.X = ±0.25mm  
X.XX = ±0.10mm  
X.XXX = ±0.01mm  
ANGLES = ±5°  
UNLESS STATED

**MATERIAL:**  
SEE ABOVE  
**FINISH:** SEE ABOVE  
**S/AREA:** mm<sup>2</sup>

**TITLE:** JACKSCREW DATAMATE  
DIL CRIMP (LARGE BORE)  
FEMALE ASSEMBLY (NO J/S)

**DRAWING NUMBER:**  
**M80-470XXXX**  
SHT 2 OF 2