

# TLE8250GVIO

High Speed CAN-Transceiver

## Data Sheet

Rev. 1.1, 2014-10-08

Automotive Power

## Table of Contents

<b>1</b>	<b>Overview</b> .....	<b>3</b>
<b>2</b>	<b>Block Diagram</b> .....	<b>4</b>
<b>3</b>	<b>Pin Configuration</b> .....	<b>5</b>
3.1	Pin Assignment .....	5
3.2	Pin Definitions and Functions .....	5
<b>4</b>	<b>Functional Description</b> .....	<b>6</b>
4.1	High Speed CAN Physical Layer .....	6
4.2	Operation Modes .....	8
4.3	Normal Operation Mode .....	9
4.4	Stand-By Mode .....	9
4.5	Power Down .....	9
<b>5</b>	<b>Fail Safe Functions</b> .....	<b>10</b>
5.1	Short circuit protection .....	10
5.2	Open Logic Pins .....	10
5.3	TxD Time-Out function .....	10
5.4	Under-Voltage detection .....	11
5.5	Over-Temperature protection .....	12
<b>6</b>	<b>General Product Characteristics</b> .....	<b>13</b>
6.1	Absolute Maximum Ratings .....	13
6.2	Functional Range .....	14
6.3	Thermal Characteristics .....	14
<b>7</b>	<b>Electrical Characteristics</b> .....	<b>15</b>
7.1	Functional Device Characteristics .....	15
7.2	Diagrams .....	18
<b>8</b>	<b>Application Information</b> .....	<b>20</b>
8.1	Application Example .....	20
8.2	Output Characteristics of the RxD Pin .....	21
8.3	Further Application Information .....	25
<b>9</b>	<b>Package Outlines</b> .....	<b>26</b>
<b>10</b>	<b>Revision History</b> .....	<b>27</b>



## 1 Overview

### Features

- Fully compatible to ISO 11898-2
- Wide common mode range for electromagnetic immunity (EMI)
- Very low electromagnetic emission (EME)
- Excellent ESD robustness
- Extended supply range at  $V_{CC}$  and  $V_{IO}$
- Suitable for 5V and 3.3V microcontroller I/O voltages
- CAN Short-Circuit proof to ground, battery and  $V_{CC}$
- TxD time-out function
- Low CAN bus leakage current in Power Down mode
- Over temperature protection
- Protected against automotive transients
- CAN data transmission rate up to 1 MBit/s
- $V_{IO}$  input for voltage adaption to the micro controller supply
- Green Product (RoHS compliant)
- AEC Qualified

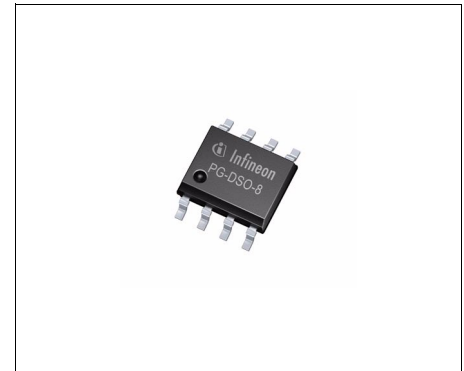

**PG-DSO-8**

### Description

The TLE8250GVIO is a transceiver designed for CAN networks in automotive and industrial applications. As an interface between the physical bus layer and the CAN protocol controller, the TLE8250GVIO drives the signals to the bus and protects the microcontroller against disturbances coming from the network. Based on the high symmetry of the CANH and CANL signals, the TLE8250GVIO provides a very low level of electromagnetic emission (EME) within a broad frequency range. The TLE8250GVIO is integrated in a RoHS complaint PG-DSO-8 package and fulfills or exceeds the requirements of the ISO11898-2.

As a successor to the first generation of HS CAN transceivers, the TLE8250GVIO is fully pin and function compatible to his predecessor model, the TLE6250GV33. The TLE8250GVIO is optimized to provide an excellent passive behavior in Power Down mode. This feature makes the TLE8250GVIO extremely suitable for mixed supply CAN networks.

Based on the Infineon Smart Power Technology SPT<sup>®</sup>, the TLE8250GVIO provides industry leading ESD robustness together with a very high electromagnetic immunity (EMI). The Infineon Smart Power Technology SPT<sup>®</sup> allows bipolar and CMOS control circuitry in accordance with DMOS power devices to exist on the same monolithic circuit. The TLE8250GVIO and the Infineon SPT<sup>®</sup> technology are AEC qualified and tailored to withstand the harsh conditions of the Automotive Environment.

Two different operation modes, additional Fail Safe features like a TxD time-out and the optimized output slew rates on the CANH and CANL signals are making the TLE8250GVIO the ideal choice for large CAN networks with high data rates.

Type	Package	Marking
TLE8250GVIO	PG-DSO-8	8250GVIO

## 2 Block Diagram

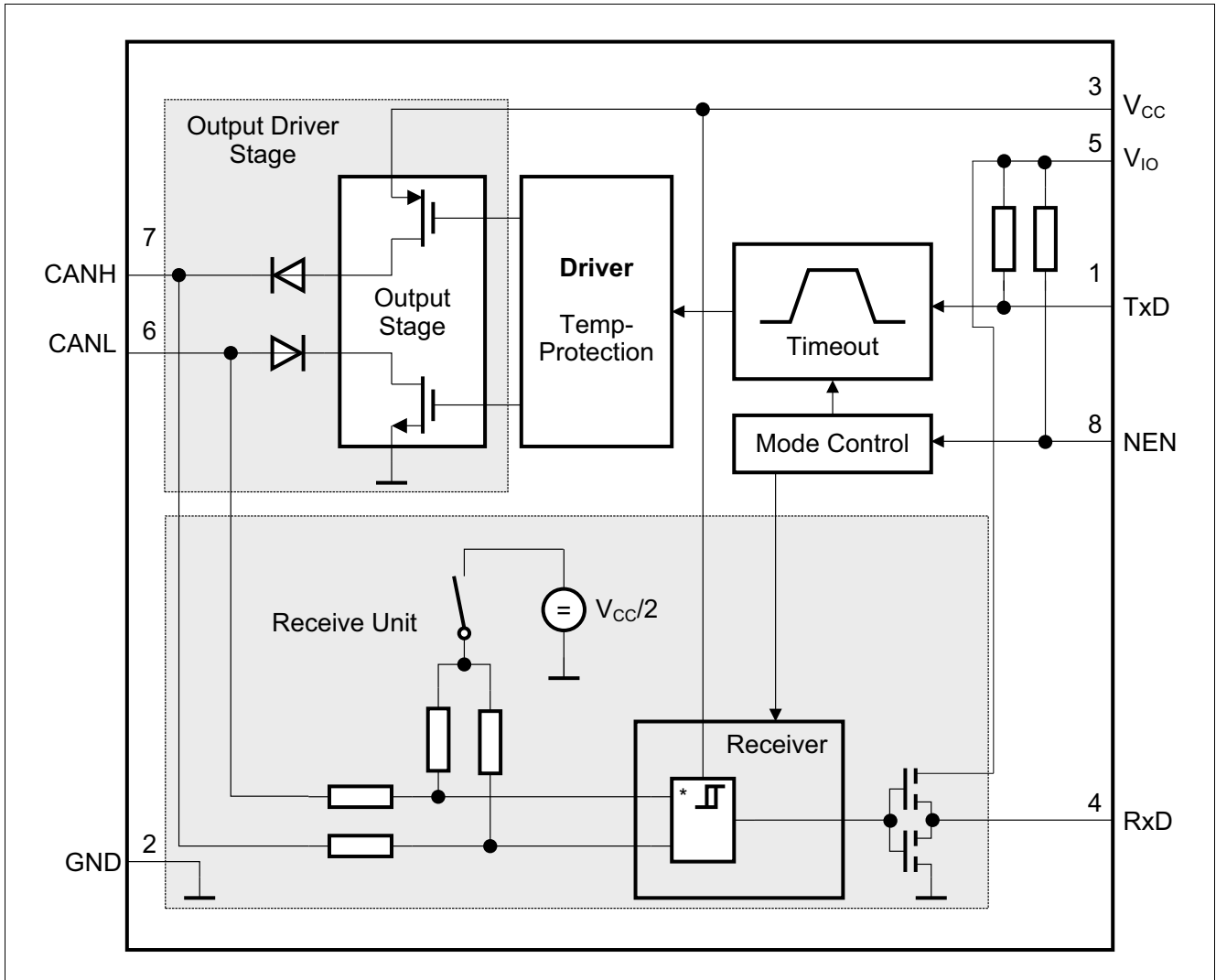

Figure 1 Block Diagram

Note: In comparison to the TLE6250GV33 the pin 8 (INH) was renamed to the term NEN, the function remains unchanged. NEN stands for Not ENable.

### 3 Pin Configuration

#### 3.1 Pin Assignment

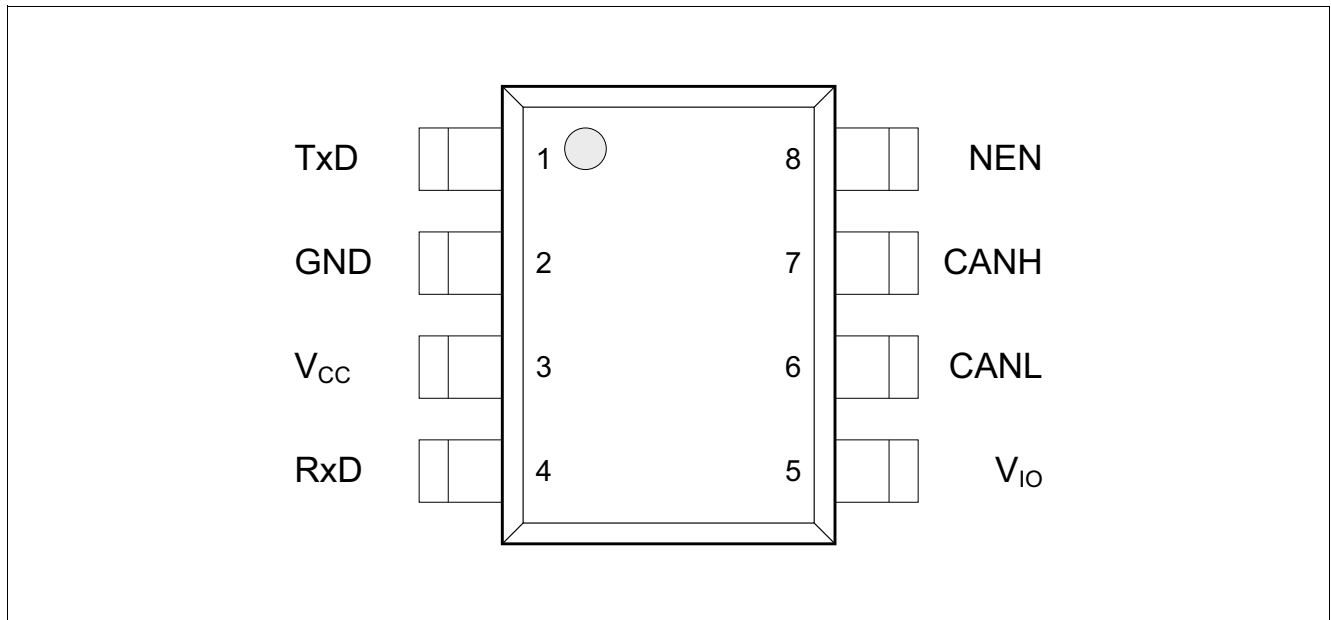

Figure 2 Pin Configuration

#### 3.2 Pin Definitions and Functions

Table 1 Pin Definition and Functions

Pin	Symbol	Function
1	TxD	<b>Transmit Data Input;</b> internal pull-up to $V_{IO}$ , “Low” for “Dominant” state.
2	GND	<b>Ground</b>
3	$V_{CC}$	<b>Transceiver Supply Voltage;</b> 100 nF decoupling capacitor to GND required.
4	RxD	<b>Receive Data Output;</b> “Low” in “Dominant” state.
5	$V_{IO}$	<b>Digital Supply Voltage Input;</b> Supply voltage input to adapt the logical input and output voltage levels of the transceiver to the microcontroller supply. 100 nF decoupling capacitor to GND required.
6	CANL	<b>CAN Bus Low level I/O;</b> “Low “ in “Dominant” state.
7	CANH	<b>CAN Bus High level I/O;</b> “High” Sin “Dominant” state.
8	NEN	<b>Not ENable Input<sup>1)</sup>;</b> internal pull-up to $V_{IO}$ , “Low” for Normal Operation mode.

1) The naming of pin 8 is different between the TLE8250GVIO and its forerunner model the TLE6250GV33. The function of pin 8 remains the same.

## 4 Functional Description

CAN is a serial bus system that connects microcontrollers, sensor and actuators for real-time control applications. The usage of the **C**ontrol **A**rea **N**etwork (abbreviated CAN) within road vehicles is described by the international standard ISO 11898. According to the 7 layer OSI reference model the physical layer of a CAN bus system specifies the data transmission from one CAN node to all other available CAN nodes inside the network. The physical layer specification of a CAN bus system includes all electrical and mechanical specifications of a CAN network. The CAN transceiver is part of the physical layer specification. Several different physical layer standards of CAN networks have been developed over the last years. The TLE8250GVIO is a High Speed CAN transceiver without any dedicated Wake-Up function. High Speed CAN Transceivers without Wake-Up function are defined by the international standard ISO 11898-2.

### 4.1 High Speed CAN Physical Layer

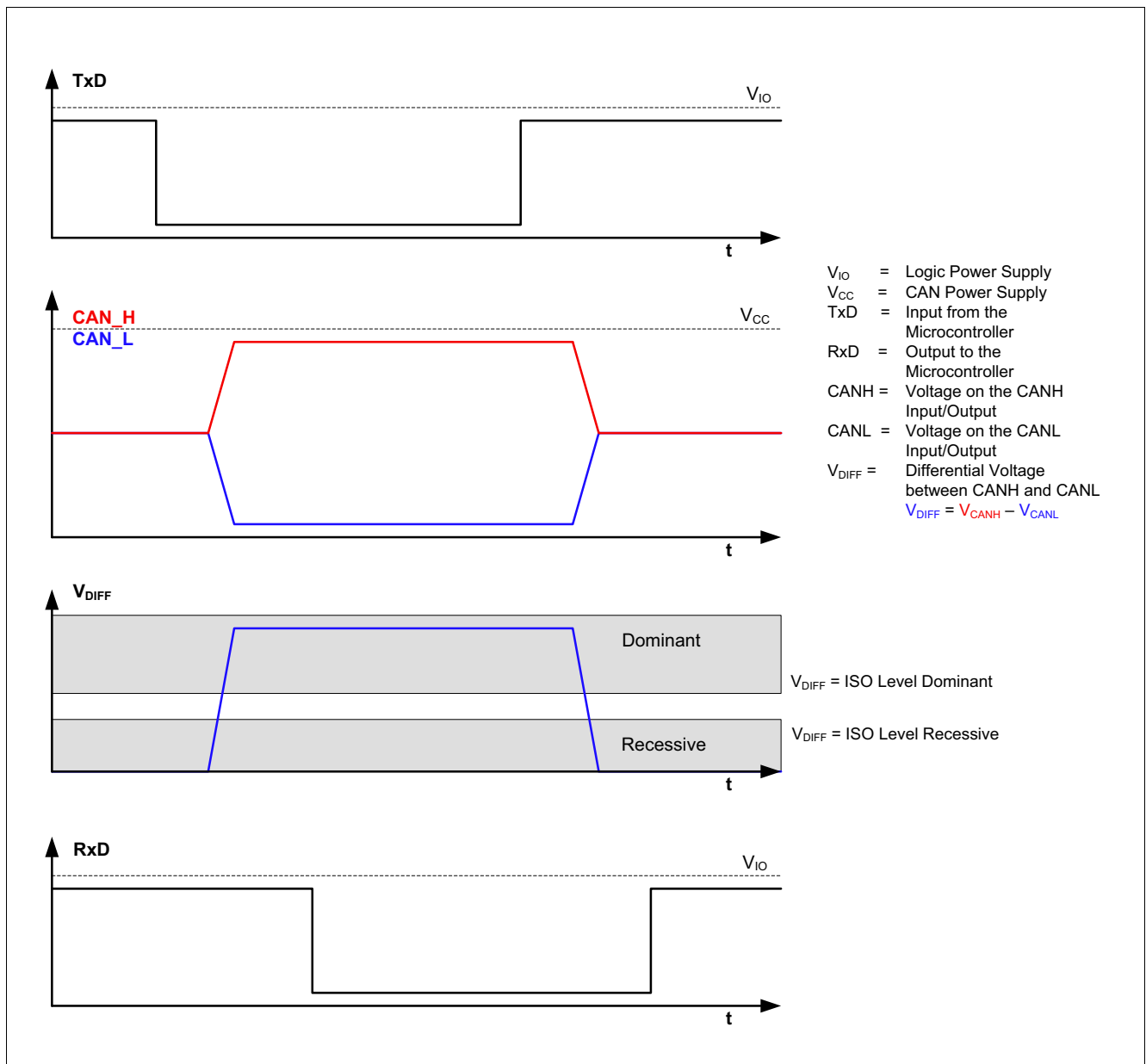

Figure 3 High Speed CAN Bus Signals and Logic Signals

The TLE8250GVIO is a High Speed CAN transceiver, operating as an interface between the CAN controller and the physical bus medium. A HS CAN network is a two wire, differential network which allows data transmission rates up to 1 MBit/s. Characteristic for a HS CAN network are the two signal states on the CAN bus: “Dominant” and “Recessive” (see [Figure 3](#)).

The pins CANH and CANL are the interface to the CAN bus and both pins operate as a input and as an output. The pins RxD and TxD are the interface to the microcontroller. The pin TxD is the serial data input from the CAN controller, the pin RxD is the serial data output to the CAN controller. As shown in [Figure 1](#), the HS CAN transceiver TLE8250GVIO has a receive and a transmit unit, allowing the transceiver to send data to the bus medium and monitor the data from the bus medium at the same time. The HS CAN transceiver TLE8250GVIO converts the serial data stream available on the transmit data input TxD, into a differential output signal on CAN bus, provided by the pins CANH and CANL. The receiver stage of the TLE8250GVIO monitors the data on the CAN bus and converts them to a serial, single ended signal on the RxD output pin. A logical “Low” signal on the TxD pin creates a “Dominant” signal on the CAN bus, followed by a logical “Low” signal on the RxD pin (see [Figure 3](#)). The feature, broadcasting data to the CAN bus and listening to the data traffic on the CAN bus simultaneous is essential to support the bit to bit arbitration inside CAN networks.

The voltage levels for HS CAN transceivers are defined by the ISO 11898-2 and the ISO 11898-5 standards. If a data bit is “Dominant” or “Recessive” depends on the voltage difference between pins CANH and CANL:

$$V_{\text{DIFF}} = V_{\text{CANH}} - V_{\text{CANL}}$$

In comparison to other differential network protocols the differential signal on a CAN network can only be larger or equal to 0 V. To transmit a “Dominant” signal to the CAN bus the differential signal  $V_{\text{DIFF}}$  is larger or equal to 1.5 V. To receive a “Recessive” signal from the CAN bus the differential  $V_{\text{DIFF}}$  is smaller or equal to 0.5 V.

Partially supplied CAN networks are networks where the CAN bus participants have different power supply conditions. Some nodes are connected to the power supply, some other nodes are disconnected from the power supply. Regardless, if the CAN bus participant is supplied or not supplied, each participant connected to the common bus media must not disturb the communication. The TLE8250GVIO is designed to support partially supplied networks. In Power Down mode, the receiver input resistors are switched off and the transceiver input is high resistive.

The voltage level on the digital input TxD and the digital output RxD is determined by the power supply level at the pin  $V_{\text{IO}}$ . Depending on voltage level at the  $V_{\text{IO}}$  pin, the signal levels on the logic pins (NEN, TxD and RxD) are compatible to microcontrollers with 5 V or 3.3 V I/O supply. Usually the  $V_{\text{IO}}$  power supply of the transceiver is connected to same power supply as I/O power supply of the microcontroller.

## 4.2 Operation Modes

Two different operation modes are available on TLE8250GVIO. Each mode with specific characteristics in terms of quiescent current or data transmission. For the mode selection the digital input pin NEN is used. **Figure 4** illustrates the different mode changes depending on the status of the NEN pin. After supplying  $V_{CC}$  and  $V_{IO}$  to the HS CAN transceiver, the TLE8250GVIO starts in Stand-By mode. The internal pull-up resistor is setting the TLE8250GVIO to Stand-By per default. If the microcontroller is up and running the TLE8250GVIO can change to operation mode within the time for mode change  $t_{Mode}$ .

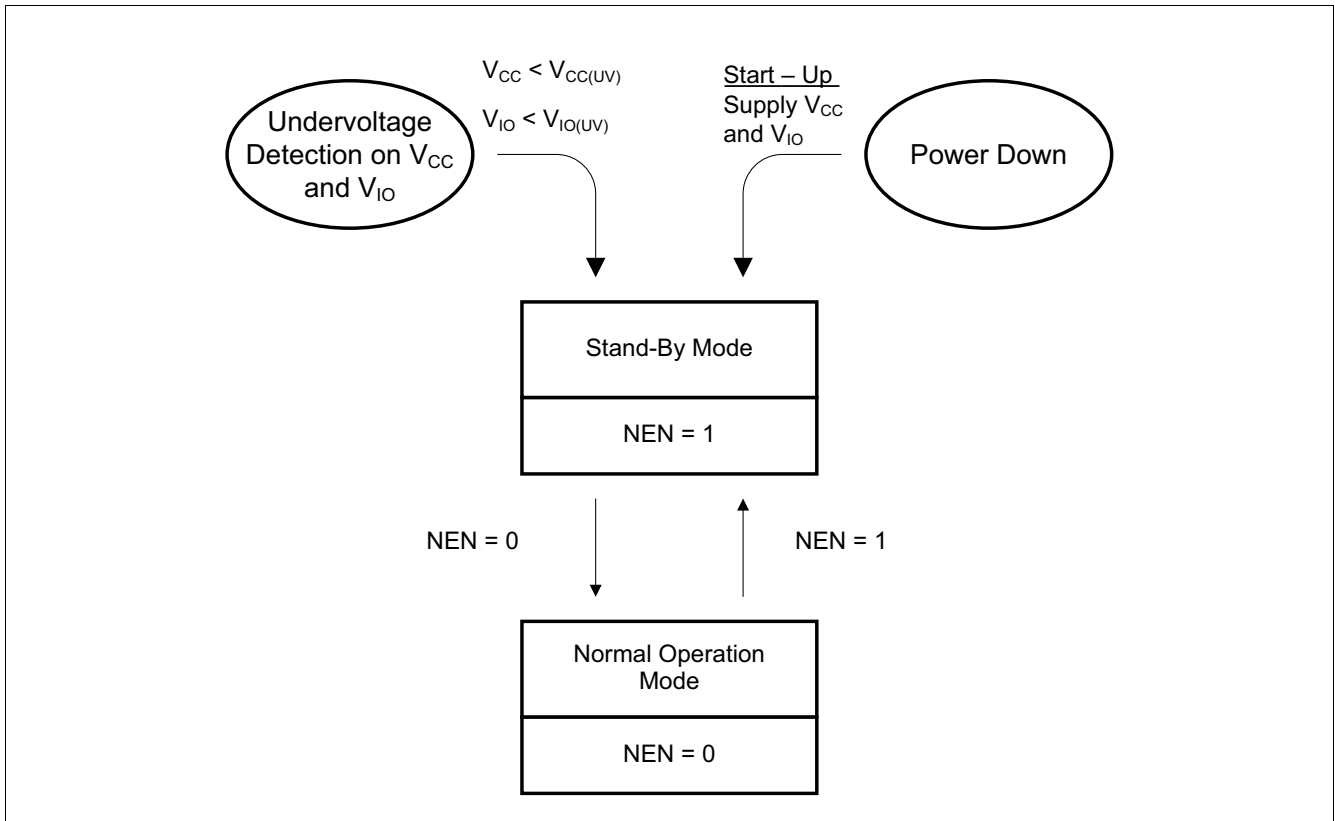

**Figure 4 Operation Modes**

The TLE8250GVIO has 2 major operation modes:

- Stand-By mode
- Normal Operation mode

**Table 2 Operating modes**

Mode	NEN	Bus Bias	Comments
Normal Operation	“Low”	$V_{CC}/2$	Output driver stage is active. Receiver unit is active.
Stand-By	“High”	Floating	Output driver stage is disabled. Receiver unit is disabled.
$V_{CC}$ off	“Low” or “High”	Floating	Output driver stage is disabled. Receiver unit is disabled.

### 4.3 Normal Operation Mode

In Normal Operation mode the HS CAN transceiver TLE8250GVIO sends the serial data stream on the TxD pin to the CAN bus while at the same time the data available on the CAN bus are monitored to the RxD pin. In Normal Operation mode all functions of the TLE8250GVIO are active:

- The output driver stage is active and drives data from the TxD to the CAN bus.
- The receiver unit is active and provides the data from the CAN bus to the RxD pin.
- The bus basing is set to  $V_{CC}/2$ .
- The under-voltage monitoring on the power supply  $V_{CC}$  and on the power supply  $V_{IO}$  is active.

To enter the Normal Operation mode set the pin NEN to logical “Low” (see [Table 2](#) or [Figure 4](#)). The NEN pin has an internal pull-up resistors to the power-supply  $V_{IO}$ .

### 4.4 Stand-By Mode

Stand-By mode is an idle mode of the TLE8250GVIO with optimized power consumption. In Stand-By mode the TLE8250GVIO can not send or receive any data. The output driver stage and the normal receiver unit are disabled. Both CAN bus pins, CANH and CANL are floating.

- The output driver stage is disabled.
- The receiver unit is disabled.
- The bus basing is floating.
- The under-voltage monitoring on the power supply  $V_{CC}$  and on the power supply  $V_{IO}$  is active.

To enter the Stand-By mode set the pin NEN to logical “High” (see [Table 2](#) or [Figure 4](#)). The NEN pin has an internal pull-up resistor to the power-supply  $V_{IO}$ . In case the Stand-By mode will not be used in the application, the NEN pin needs to get connected to GND.

### 4.5 Power Down

Power Down mode means the TLE8250GVIO is not supplied. In Power Down the differential input resistors of the receiver stage are switched off. The CANH and CANL bus interface of the TLE8250GVIO acts as an high impedance input with a very small leakage current. The high ohmic input doesn't influence the “Recessive” level of the CAN network and allows an optimized EME performance of the whole CAN network.

## 5 Fail Safe Functions

### 5.1 Short circuit protection

The CANH and CANL bus outputs are short-circuit-proof, either against GND or a positive supply voltage. A current limiting circuit protects the transceiver against damages. If the device is heating up due to a continuous short on CANH or CANL, the internal over-temperature protection switches off the bus transmitter.

### 5.2 Open Logic Pins

All logic input pins have internal pull-up resistor to  $V_{IO}$ . In case the  $V_{IO}$  supply is activated and the logical pins are open or floating, the TLE8250GVIO enters into the Stand-By mode per default. In Stand-By mode the output driver stage of the TLE8250GVIO is disabled, the bus biasing is shut off and the HS CAN TLE8250GVIO transceiver will not influence the data on the CAN bus.

### 5.3 TxD Time-Out function

The TxD Time-out feature protects the CAN bus against permanent blocking in case the logical signal on the TxD pin is continuously “Low”. A continuous “Low” signal on the TxD pin can have it’s root cause in a locked-up microcontroller or a short on the printed circuit board for example. In Normal Operation mode, a logical “Low” signal on the TxD pin for the time  $t > t_{TxD}$  enables the TxD Time-out feature and the TLE8250GVIO disables the output driver stage (see [Figure 5](#)). The receive unit is still active and the data on the bus are still monitored by the RxD output pin.

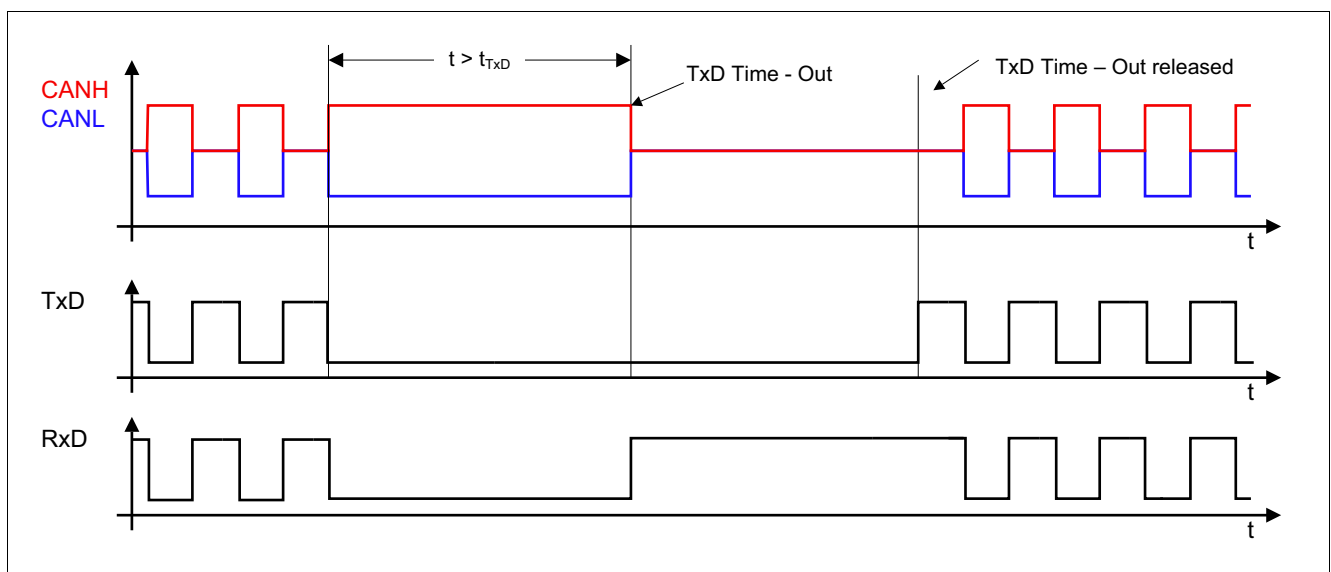

Figure 5 TxD Time-Out function

[Figure 5](#) shows the way how the transmission stage is deactivated and activated again. A permanent “Low” signal on the TxD input pin activates the TxD time-out function and deactivates the transmitter output stage. To release the transmitter output stage after a TxD time-out event the TLE8250GVIO requires a signal change on the TxD input pin from logical “Low” to logical “High”.

### 5.4 Under-Voltage detection

The HS CAN Transceiver TLE8250GVIO is equipped with an under-voltage detection on the power supply  $V_{CC}$  and the power supply  $V_{IO}$ . In case of an under-voltage event on  $V_{CC}$  or  $V_{IO}$ , the under-voltage detection changes the operation mode of TLE8250GVIO to the Stand-By mode, regardless to the logical signal on the NEN pin (see [Figure 6](#)). If the transceiver TLE8250GVIO recovers from the under-voltage event, the operation mode returns to the programmed mode by the NEN pin.

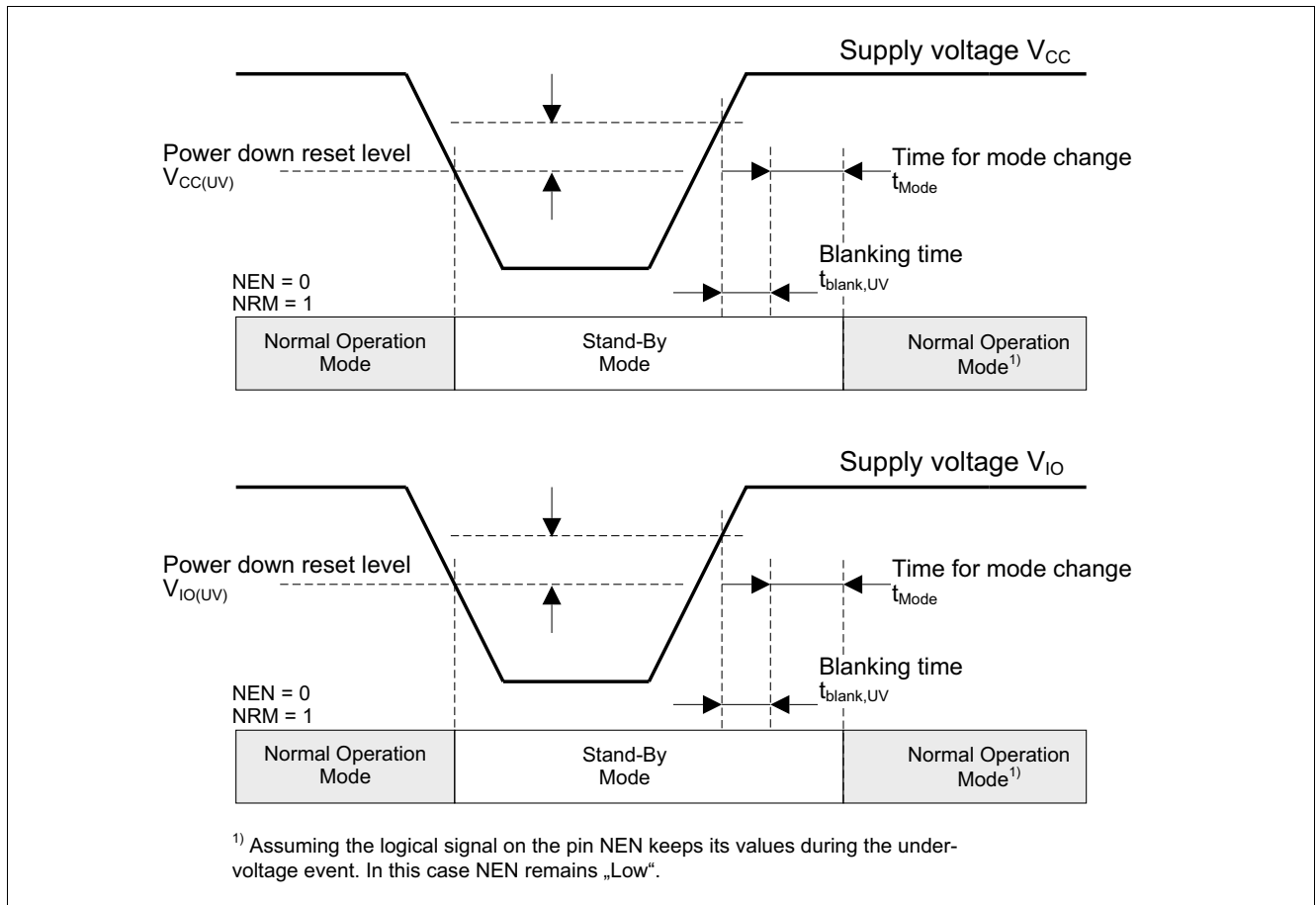
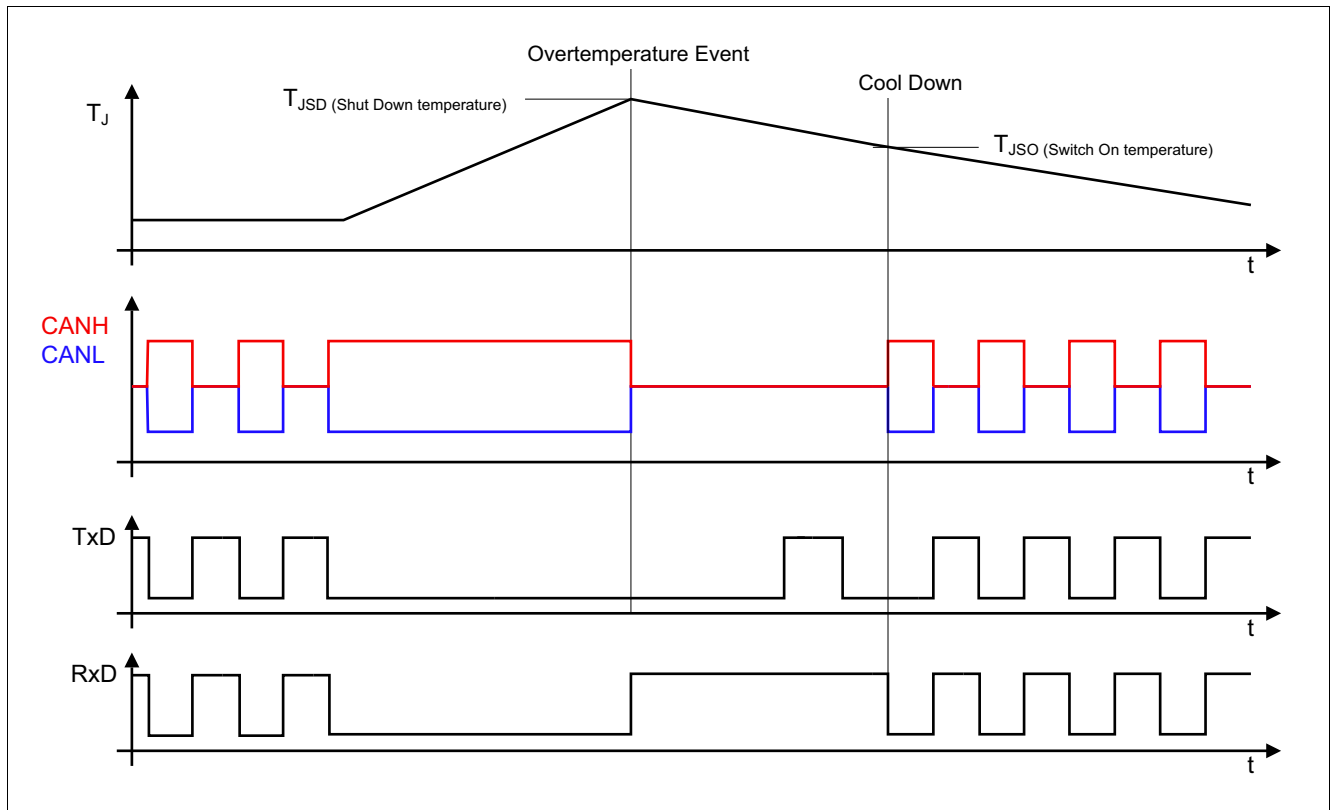

Figure 6 Under-Voltage detection on  $V_{CC}$  and  $V_{IO}$

### 5.5 Over-Temperature protection



**Figure 7 Over-Temperature protection**

The TLE8250GVIO has an integrated over-temperature detection to protect the device against thermal overstress of the output driver stage. In case of an over-temperature event, the temperature sensor will disable the output driver stage (see [Figure 1](#)). After the device cools down the output driver stage is activated again (see [Figure 7](#)). Inside the temperature sensor a hysteresis is implemented.

## 6 General Product Characteristics

### 6.1 Absolute Maximum Ratings

**Table 3 Absolute Maximum Ratings Voltages, Currents and Temperatures<sup>1)</sup>**

All voltages with respect to ground; positive current flowing into pin;  
(unless otherwise specified)

Pos.	Parameter	Symbol	Limit Values		Unit	Remarks
			Min.	Max.		
<b>Voltages</b>						
6.1.1	Transceiver Supply Voltage	$V_{CC}$	-0.3	6.0	V	–
6.1.2	Logic Supply Voltage	$V_{IO}$	-0.3	6.0	V	–
6.1.3	CANH DC voltage versus GND	$V_{CANH}$	-40	40	V	–
6.1.4	CANL DC voltage versus GND	$V_{CANL}$	-40	40	V	–
6.1.5	Differential voltage between CANH and CANL	$V_{CAN\ diff}$	-40	40	V	
6.1.6	Logic voltages at NEN, TxD, RxD	$V_I$	-0.3	6.0	V	–
<b>Temperatures</b>						
6.1.7	Junction temperature	$T_j$	-40	150	°C	–
6.1.8	Storage temperature	$T_S$	- 55	150	°C	–
<b>ESD Resistivity</b>						
6.1.9	ESD Resistivity at CANH, CANL versus GND	$V_{ESD}$	-8	8	kV	Human Body Model (100pF via 1.5 kΩ) <sup>2)</sup>
6.1.10	ESD Resistivity all other pins	$V_{ESD}$	-2	2	kV	Human Body Model (100pF via 1.5 kΩ) <sup>2)</sup>

1) Not subject to production test, specified by design

2) ESD susceptibility HBM according to EIA / JESD 22-A 114

*Note: Within the functional range the IC operates as described in the circuit description. The electrical characteristics are specified within the conditions given in the related electrical characteristics table.*

## 6.2 Functional Range

**Table 4 Operating Range**

Pos.	Parameter	Symbol	Limit Values		Unit	Conditions
			Min.	Max.		
<b>Supply Voltages</b>						
6.2.1	Transceiver Supply Voltage	$V_{CC}$	4.5	5.5	V	–
6.2.2	Logical Supply Voltage	$V_{IO}$	3.0	5.5	V	–
<b>Thermal Parameters</b>						
6.2.3	Junction temperature	$T_j$	-40	150	°C	<sup>1)</sup>

1) Not subject to production test, specified by design

*Note: Within the functional range the IC operates as described in the circuit description. The electrical characteristics are specified within the conditions given in the related electrical characteristics table.*

## 6.3 Thermal Characteristics

*Note: This thermal data was generated in accordance with JEDEC JESD51 standards. For more information, go to [www.jedec.org](http://www.jedec.org).*

**Table 5 Thermal Resistance<sup>1)</sup>**

Pos.	Parameter	Symbol	Limit Values			Unit	Remarks
			Min.	Typ.	Max.		
<b>Thermal Resistance</b>							
6.3.1	Junction to Ambient <sup>1)</sup>	$R_{thJA}$	–	130	–	K/W	<sup>2)</sup>
<b>Thermal Shutdown Junction Temperature</b>							
6.3.2	Thermal shutdown temp.	$T_{JSD}$	150	175	200	°C	–
6.3.3	Thermal shutdown hysteresis	$\Delta T$		10		K	–

1) Not subject to production test, specified by design

2) Specified  $R_{thJA}$  value is according to Jedec JESD51-2,-7 at natural convection on FR4 2s2p board; The Product (TLE8250GVIO) was simulated on a 76.2 x 114.3 x 1.5 mm board with 2 inner copper layers (2 x 70µm Cu, 2 x 35µm Cu).

## 7 Electrical Characteristics

### 7.1 Functional Device Characteristics

**Table 6 Electrical Characteristics**

4.5 V <  $V_{CC}$  < 5.5 V; 3.0 V <  $V_{IO}$  < 5.5 V;  $R_L = 60 \Omega$ ;  $-40^\circ\text{C} < T_J < +150^\circ\text{C}$ ; all voltages with respect to ground; positive current flowing into pin; unless otherwise specified.

Pos.	Parameter	Symbol	Limit Values			Unit	Remarks
			Min.	Typ.	Max.		
<b>Current Consumption</b>							
7.1.1	Current consumption on $V_{CC}$	$I_{CC}$	–	6	10	mA	“Recessive” state; $V_{TxD} = V_{IO}$
7.1.2	Current consumption on $V_{CC}$	$I_{CC}$	–	45	70	mA	“Dominant” state; $V_{TxD} = 0 \text{ V}$
7.1.3	Current consumption	$I_{CC(STB)}$	–	7	15	$\mu\text{A}$	Stand-By mode; $TxD = V_{IO}$ , NEN = “Low”
7.1.4	Current consumption	$I_{IO}$	–	–	1	mA	Normal Operation mode NEN = “Low”
<b>Supply Resets</b>							
7.1.5	$V_{CC}$ under-voltage monitor	$V_{CC(UV)}$	1.3	3.2	4.3	V	–
7.1.6	$V_{CC}$ under-voltage monitor hysteresis	$V_{CC(UV,H)}$	–	200	–	mV	<sup>1)</sup>
7.1.7	$V_{IO}$ under-voltage monitor	$V_{IO(UV)}$	1.3	2.4	2.8	V	–
7.1.8	$V_{IO}$ under-voltage monitor hysteresis	$V_{IO(UV,H)}$	–	200	–	mV	<sup>1)</sup>
7.1.9	$V_{CC}$ and $V_{IO}$ under-voltage blanking time	$t_{blank(UV)}$	–	15	–	$\mu\text{s}$	<sup>1)</sup>
<b>Receiver Output: RxD</b>							
7.1.10	HIGH level output current	$I_{RD,H}$	–	-4	-2	mA	$V_{RxD} = 0.8 \times V_{IO}$ $V_{DIFF} < 0.5 \text{ V}$
7.1.11	LOW level output current	$I_{RD,L}$	2	4	–	mA	$V_{RxD} = 0.2 \times V_{IO}$ $V_{DIFF} > 0.9 \text{ V}$
<b>Transmission Input: TxD</b>							
7.1.12	HIGH level input voltage threshold	$V_{TD,H}$	–	$0.5 \times V_{IO}$	$0.7 \times V_{IO}$	V	“Recessive” state
7.1.13	LOW level input voltage threshold	$V_{TD,L}$	$0.3 \times V_{IO}$	$0.4 \times V_{IO}$	–	V	“Dominant” state
7.1.14	TxD pull-up resistance	$R_{TD}$	10	25	50	$\text{k}\Omega$	–
7.1.15	TxD input hysteresis	$V_{HYS(TxD)}$	–	200	–	mV	<sup>1)</sup>
7.1.16	TxD permanent dominant disable time	$t_{TxD}$	0.3	–	1.0	ms	–

**Electrical Characteristics**
**Table 6 Electrical Characteristics (cont'd)**

4.5 V <  $V_{CC}$  < 5.5 V; 3.0 V <  $V_{IO}$  < 5.5 V;  $R_L = 60 \Omega$ ;  $-40^\circ\text{C} < T_J < +150^\circ\text{C}$ ; all voltages with respect to ground; positive current flowing into pin; unless otherwise specified.

Pos.	Parameter	Symbol	Limit Values			Unit	Remarks
			Min.	Typ.	Max.		
<b>Not Enable Input NEN</b>							
7.1.17	HIGH level input voltage threshold	$V_{NEN,H}$	–	$0.5 \times V_{IO}$	$0.7 \times V_{IO}$	V	Stand-By mode;
7.1.18	LOW level input voltage threshold	$V_{NEN,L}$	$0.3 \times V_{IO}$	$0.4 \times V_{IO}$	–	V	Normal Operation mode;
7.1.19	NEN pull-up resistance	$R_{NEN}$	10	25	50	k $\Omega$	–
7.1.20	NEN input hysteresis	$V_{HYS(NEN)}$	–	200	–	mV	<sup>1)</sup>
<b>Bus Receiver</b>							
7.1.21	Differential receiver threshold “Dominant”	$V_{DIFF,(D)}$	–	0.75	0.9	V	Normal Operation mode
7.1.22	Differential receiver threshold “Recessive”	$V_{DIFF,(R)}$	0.5	0.6	–		Normal Operation mode
7.1.23	Differential receiver input range - “Dominant”	$V_{diff,rdN}$	0.9	–	5.0	V	Normal Operation mode
7.1.24	Differential receiver input range - “Recessive”	$V_{diff,drN}$	-1.0	–	0.5	V	Normal Operation mode
7.1.25	Common Mode Range	CMR	-12	–	12	V	$V_{CC} = 5 \text{ V}$
7.1.26	Differential receiver hysteresis	$V_{diff,hys}$	–	100	–	mV	<sup>1)</sup>
7.1.27	CANH, CANL input resistance	$R_i$	10	20	30	k $\Omega$	“Recessive” state
7.1.28	Differential input resistance	$R_{diff}$	20	40	60	k $\Omega$	“Recessive” state
7.1.29	Input resistance deviation between CANH and CANL	$\Delta R_i$	-3	–	3	%	<sup>1)</sup> “Recessive” state
7.1.30	Input capacitance CANH, CANL versus GND	$C_{IN}$	–	20	40	pF	<sup>1)</sup> $V_{TXD} = V_{CC}$
7.1.31	Differential input capacitance	$C_{InDiff}$	–	10	20	pF	<sup>1)</sup> $V_{TXD} = V_{CC}$
<b>Bus Transmitter</b>							
7.1.32	CANL/CANH recessive output voltage	$V_{CANL/H}$	2.0	2.5	3.0	V	$V_{TXD} = V_{IO}$ ; no load
7.1.33	CANH, CANL recessive output voltage difference	$V_{diff}$	-500	–	50	mV	$V_{TXD} = V_{IO}$ ; no load
7.1.34	CANL dominant output voltage	$V_{CANL}$	0.5	–	2.25	V	$4.75 \text{ V} < V_{CC} < 5.25 \text{ V}$ , $V_{TXD} = 0 \text{ V}$ , $50 \Omega < R_L < 65 \Omega$ ;
7.1.35	CANH dominant output voltage	$V_{CANH}$	2.75	–	4.5	V	$4.75 \text{ V} < V_{CC} < 5.25 \text{ V}$ , $V_{TXD} = 0 \text{ V}$ , $50 \Omega < R_L < 65 \Omega$ ;
7.1.36	CANH, CANL dominant output voltage difference $V_{diff} = V_{CANH} - V_{CANL}$	$V_{diff}$	1.5	–	3.0	V	$4.75 \text{ V} < V_{CC} < 5.25 \text{ V}$ , $V_{TXD} = 0 \text{ V}$ , $50 \Omega < R_L < 65 \Omega$ ;
7.1.37	Driver Symmetry $V_{SYM} = V_{CANH} + V_{CANL}$	$V_{SYM}$	4.5	–	5.5	V	$V_{TXD} = \text{“Low”}$ ; $V_{CC} = 5 \text{ V}$ $50 \Omega < R_L < 65 \Omega$

**Electrical Characteristics**
**Table 6 Electrical Characteristics (cont'd)**

4.5 V <  $V_{CC}$  < 5.5 V; 3.0 V <  $V_{IO}$  < 5.5 V;  $R_L = 60 \Omega$ ;  $-40^\circ\text{C} < T_J < +150^\circ\text{C}$ ; all voltages with respect to ground; positive current flowing into pin; unless otherwise specified.

Pos.	Parameter	Symbol	Limit Values			Unit	Remarks
			Min.	Typ.	Max.		
7.1.38	CANL short circuit current	$I_{CANLsc}$	50	100	200	mA	$V_{CANLshort} = 18 \text{ V}$
7.1.39	CANH short circuit current	$I_{CANHsc}$	-200	-100	-50	mA	$V_{CANHshort} = 0 \text{ V}$
7.1.40	Leakage current	$I_{CANHL,ik}$	-5	0	5	$\mu\text{A}$	$V_{CC} = 0 \text{ V}$ ; $V_{CANH} = V_{CANL}$ ; $0 \text{ V} < V_{CANH,L} < 5 \text{ V}$

**Table 6 Electrical Characteristics (cont'd)**

4.5 V <  $V_{CC}$  < 5.5 V; 3.0 V <  $V_{IO}$  < 5.5 V;  $R_L = 60 \Omega$ ;  $-40^\circ\text{C} < T_J < +150^\circ\text{C}$ ; all voltages with respect to ground; positive current flowing into pin; unless otherwise specified.

Pos.	Parameter	Symbol	Limit Values			Unit	Remarks
			Min.	Typ.	Max.		
<b>Dynamic CAN-Transceiver Characteristics</b>							
7.1.41	Propagation delay TxD-to-RxD LOW ("Recessive" to "Dominant")	$t_{d(L),TR}$	–	–	255	ns	$C_L = 100 \text{ pF}$ ; $V_{CC} = 5 \text{ V}$ ; $C_{RxD} = 15 \text{ pF}$
7.1.42	Propagation delay TxD-to-RxD HIGH ("Dominant" to "Recessive")	$t_{d(H),TR}$	–	–	255	ns	$C_L = 100 \text{ pF}$ ; $V_{CC} = 5 \text{ V}$ ; $C_{RxD} = 15 \text{ pF}$
7.1.43	Propagation delay TxD LOW to bus "Dominant"	$t_{d(L),T}$	–	110	–	ns	$C_L = 100 \text{ pF}$ ; $V_{CC} = 5 \text{ V}$ ; $C_{RxD} = 15 \text{ pF}$
7.1.44	Propagation delay TxD HIGH to bus "Recessive"	$t_{d(H),T}$	–	110	–	ns	$C_L = 100 \text{ pF}$ ; $V_{CC} = 5 \text{ V}$ ; $C_{RxD} = 15 \text{ pF}$
7.1.45	Propagation delay bus "Dominant" to RxD "Low"	$t_{d(L),R}$	–	70	–	ns	$C_L = 100 \text{ pF}$ ; $V_{CC} = 5 \text{ V}$ ; $C_{RxD} = 15 \text{ pF}$
7.1.46	Propagation delay bus "Recessive" to RxD "High"	$t_{d(H),R}$	–	100	–	ns	$C_L = 100 \text{ pF}$ ; $V_{CC} = 5 \text{ V}$ ; $C_{RxD} = 15 \text{ pF}$
7.1.47	Time for mode change	$t_{Mode}$	–	–	10	$\mu\text{s}$	1)

1) Not subject to production test, specified by design

## 7.2 Diagrams

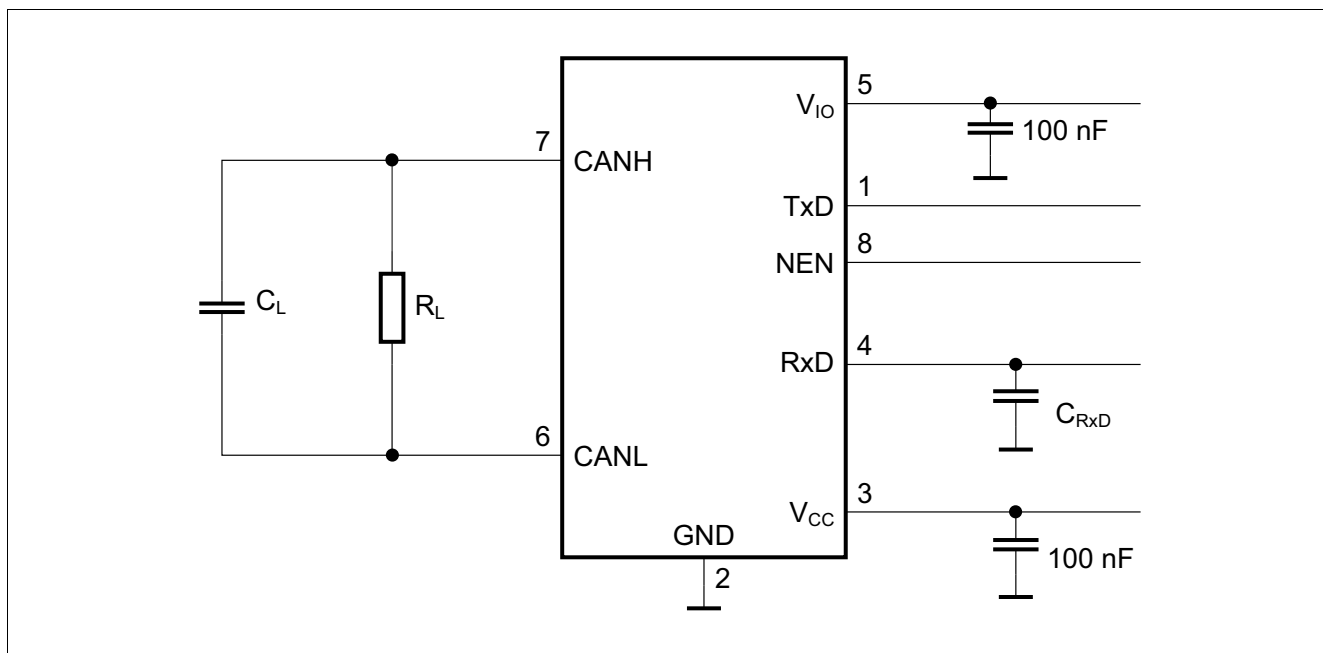

**Figure 8 Simplified test circuit**

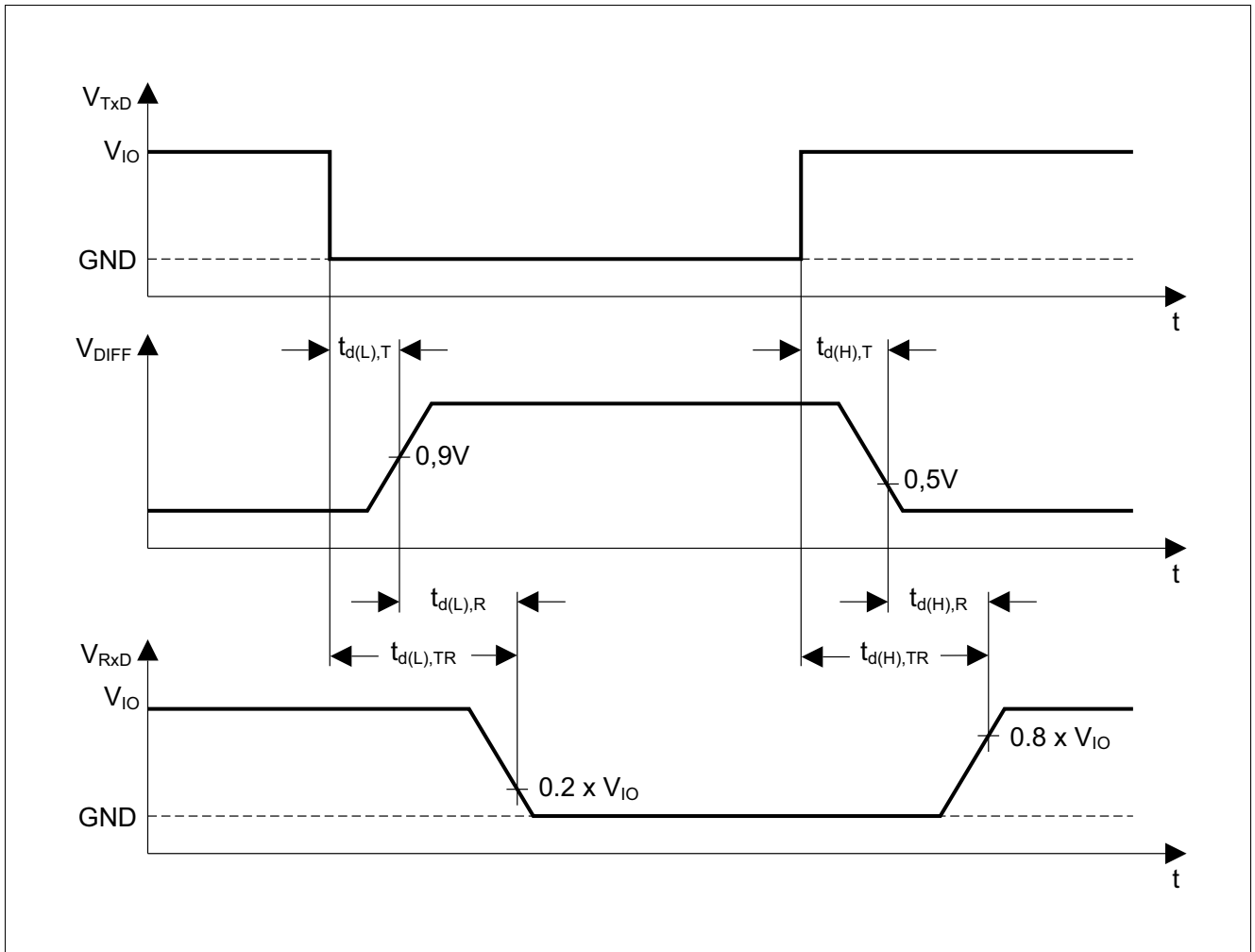

Figure 9 Timing diagram for dynamic characteristics

## 8 Application Information

### 8.1 Application Example

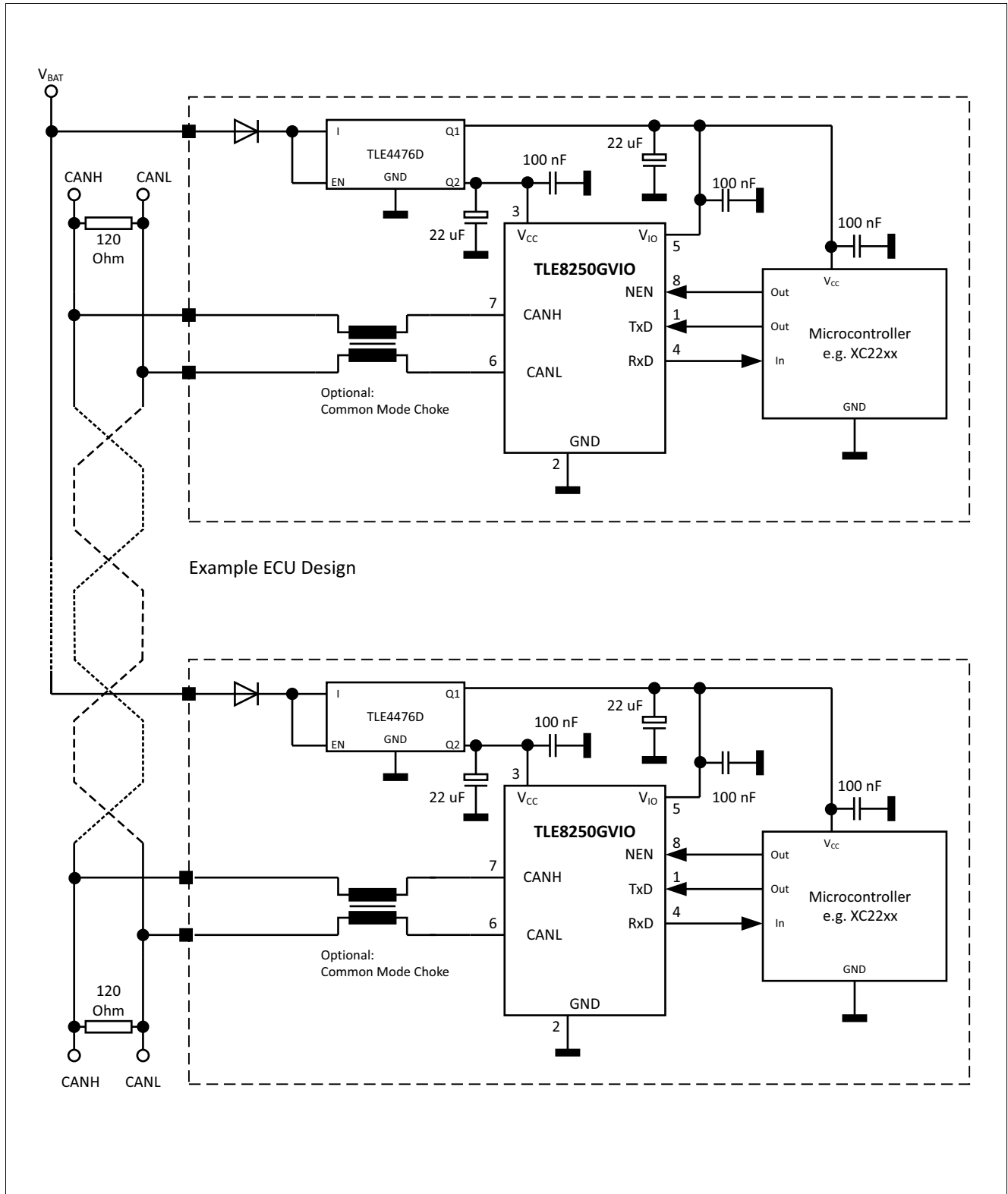

Figure 10 Simplified Application for the TLE8250GVIO

## 8.2 Output Characteristics of the RxD Pin

The RxD output pin is designed as a push-pull output stage (see [Figure 1](#)), meaning to produce a logical “Low” signal the TLE8250GVIO switches the RxD output to GND. Vice versa to produce a logical “High” signal the TLE8250GVIO switches the RxD output to  $V_{IO}$ .

The level  $V_{RxD,H}$  for a logical “High” signal on the RxD output depends on the load at the RxD output pin and therefore on the RxD output current  $I_{RD,H}$ . The voltage level  $V_{RxD,H}$  also depends on the voltage of the power supply  $V_{IO}$ . According to the operating range (see [Table 4](#)) the power supply  $V_{IO}$  can vary between 3.0 V and 5.5 V. At a  $V_{IO}$  supply of 5 V the output current of the RxD pin on the TLE8250GVIO is higher as in comparison for a  $V_{IO}$  supply of 3.3 V. For a load against the GND potential, the current  $I_{RD,H}$  is flowing out of the RxD output pin. Similar to the logical “High” signal, the level  $V_{RxD,L}$  for a logical “Low” signal on the RxD output pin depends on the input current  $I_{RD,L}$  and the power supply voltage  $V_{IO}$ . For a load against the power supply  $V_{IO}$  the current  $I_{RD,L}$  is flowing into the RxD output pin.

Currents flowing into the device are marked positive inside the data sheet and currents flowing out of the device TLE8250GVIO are marked negative inside the data sheet (see [Table 6](#)).

The diagram in [Figure 11](#) shows the output current capability of the RxD output pin depended on the chip temperature  $T_J$  at a  $V_{IO}$  power supply of 5.0 V. [Figure 12](#) shows the output current capability of the RxD output pin at a  $V_{IO}$  power supply of 3.3 V.

Both diagrams show the output current for a logical “High” level  $V_{RxD,H} = 4.6$  V. The CAN transceiver TLE8250GVIO provides a logical “High” signal on the RxD output while the signal on the CAN bus is “Recessive” (see [Figure 3](#)):

- The curve “ $V_{RxD,H} = 4.6$  V; **typ. output current**;  $V_{CC} = 5.0$  V;  $V_{IO} = 5.0$  V;” displays the typical output current at the RxD output pin of the TLE8250GVIO (see [Figure 11](#)).  
For this graph  $V_{CC} = 5.0$  V and  $V_{IO} = 5.0$  V.
- The curve “ $V_{RxD,H} = 4.6$  V; **typ. output current + 6 sigma**;  $V_{CC} = 5.0$  V;  $V_{IO} = 5.0$  V;” displays the expected maximum value of the output current at the RxD output pin (see [Figure 11](#)).  
For this graph  $V_{CC} = 5.0$  V and  $V_{IO} = 5.0$  V.
- The curve “ $V_{RxD,H} = 4.6$  V; **typ. output current - 6 sigma**;  $V_{CC} = 5.0$  V;  $V_{IO} = 5.0$  V;” displays the expected minimum value of the output current at the RxD output pin (see [Figure 11](#)).  
For this graph  $V_{CC} = 5.0$  V and  $V_{IO} = 5.0$  V.
- The curve “ $V_{RxD,H} = 4.6$  V; **typ. output current**;  $V_{CC} = 5.0$  V;  $V_{IO} = 3.3$  V;” displays the typical output current at the RxD output pin of the TLE8250GVIO (see [Figure 12](#)).  
For this graph  $V_{CC} = 5.0$  V and  $V_{IO} = 3.3$  V.
- The curve “ $V_{RxD,H} = 4.6$  V; **typ. output current + 6 sigma**;  $V_{CC} = 5.0$  V;  $V_{IO} = 3.3$  V;” displays the expected maximum value of the output current at the RxD output pin (see [Figure 12](#)).  
For this graph  $V_{CC} = 5.0$  V and  $V_{IO} = 3.3$  V.
- The curve “ $V_{RxD,H} = 4.6$  V; **typ. output current - 6 sigma**;  $V_{CC} = 5.0$  V;  $V_{IO} = 3.3$  V;” displays the expected minimum value of the output current at the RxD output pin (see [Figure 12](#)).  
For this graph  $V_{CC} = 5.0$  V and  $V_{IO} = 3.3$  V.

The diagram in [Figure 13](#) and the diagram in [Figure 14](#) show the current capability of the RxD output pin depended on the chip temperature  $T_J$ . [Figure 13](#) shows the current capability of the RxD output pin at a  $V_{IO}$  power supply of 5.0 V and [Figure 14](#) shows the current capability of the RxD output pin at a  $V_{IO}$  power supply of 3.3 V.

Both diagrams show the output current for a logical “Low” level  $V_{RxD,L} = 0.4$  V. The CAN transceiver TLE8250GVIO provides a logical “Low” signal on the RxD output while the signal on the CAN bus is “Dominant” (see [Figure 3](#)):

- The curve “ $V_{RxD,L} = 0.4$  V; **typ. output current**;  $V_{CC} = 5.0$  V;  $V_{IO} = 5.0$  V;” displays the typical output current at the RxD output pin of the TLE8250GVIO (see [Figure 13](#)).  
For this graph  $V_{CC} = 5.0$  V and  $V_{IO} = 5.0$  V.

- The curve “ $V_{\text{RxD,H}} = 0.4 \text{ V}$ ; **typ. output current + 6 sigma**;  $V_{\text{CC}} = 5.0 \text{ V}$ ;  $V_{\text{IO}} = 5.0 \text{ V}$ ,” displays the expected maximum value of the output current at the RxD output pin (see [Figure 13](#)).  
For this graph  $V_{\text{CC}} = 5.0 \text{ V}$  and  $V_{\text{IO}} = 5.0 \text{ V}$ .
- The curve “ $V_{\text{RxD,H}} = 0.4 \text{ V}$ ; **typ. output current - 6 sigma**;  $V_{\text{CC}} = 5.0 \text{ V}$ ;  $V_{\text{IO}} = 5.0 \text{ V}$ ,” displays the expected minimum value of the output current at the RxD output pin (see [Figure 13](#)).  
For this graph  $V_{\text{CC}} = 5.0 \text{ V}$  and  $V_{\text{IO}} = 5.0 \text{ V}$ .
- The curve “ $V_{\text{RxD,H}} = 0.4 \text{ V}$ ; **typ. output current**;  $V_{\text{CC}} = 5.0 \text{ V}$ ;  $V_{\text{IO}} = 3.3 \text{ V}$ ,” displays the typical output current at the RxD output pin of the TLE8250GVIO (see [Figure 14](#)).  
For this graph  $V_{\text{CC}} = 5.0 \text{ V}$  and  $V_{\text{IO}} = 3.3 \text{ V}$ .
- The curve “ $V_{\text{RxD,H}} = 0.4 \text{ V}$ ; **typ. output current + 6 sigma**;  $V_{\text{CC}} = 5.0 \text{ V}$ ;  $V_{\text{IO}} = 3.3 \text{ V}$ ,” displays the expected maximum value of the output current at the RxD output pin (see [Figure 14](#)).  
For this graph  $V_{\text{CC}} = 5.0 \text{ V}$  and  $V_{\text{IO}} = 3.3 \text{ V}$ .
- The curve “ $V_{\text{RxD,H}} = 0.4 \text{ V}$ ; **typ. output current - 6 sigma**;  $V_{\text{CC}} = 5.0 \text{ V}$ ;  $V_{\text{IO}} = 3.3 \text{ V}$ ,” displays the expected minimum value of the output current at the RxD output pin (see [Figure 14](#)).  
For this graph  $V_{\text{CC}} = 5.0 \text{ V}$  and  $V_{\text{IO}} = 3.3 \text{ V}$ .

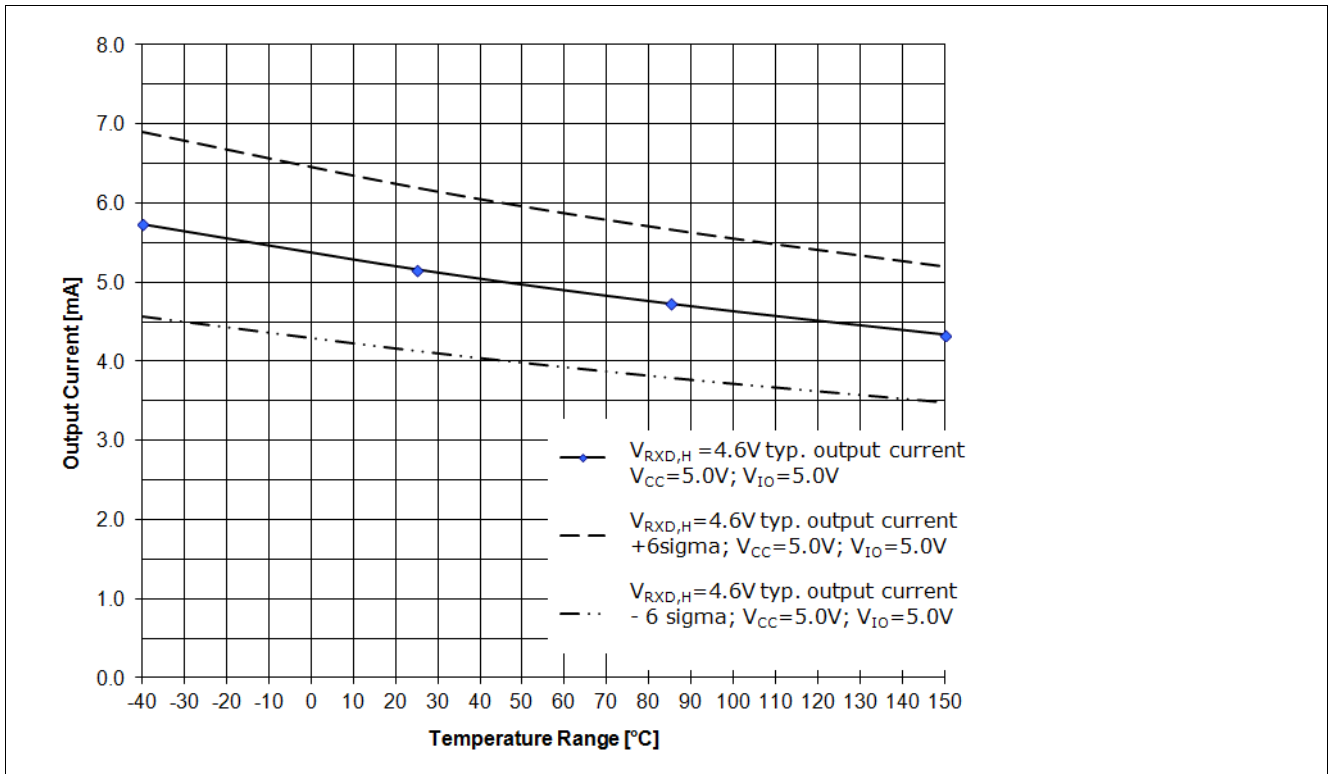

Figure 11 RxD Output driver capability for a logical “High” signal  $V_{RxD,H}=4.6\text{ V}$ ,  $V_{CC}=5.0\text{ V}$ ,  $V_{IO}=5.0\text{ V}$ <sup>1)</sup>

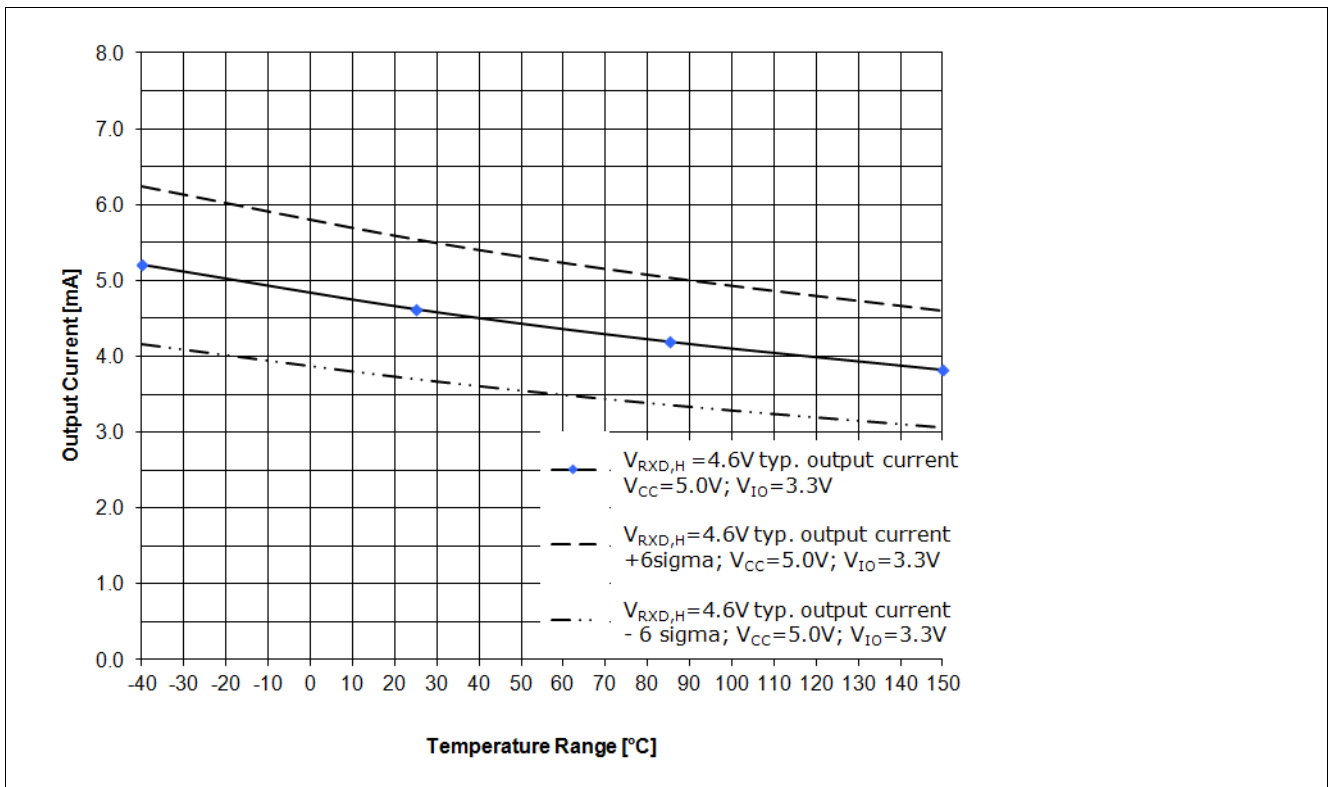

Figure 12 RxD Output driver capability for a logical “High” signal  $V_{RxD,H}=4.6\text{ V}$ ,  $V_{CC}=5.0\text{ V}$ ,  $V_{IO}=3.3\text{ V}$ <sup>1)</sup>

1) Characteristics generated by simulation and specified by design. Production test criteria is described in [Table 6](#); Pos.: 7.1.10

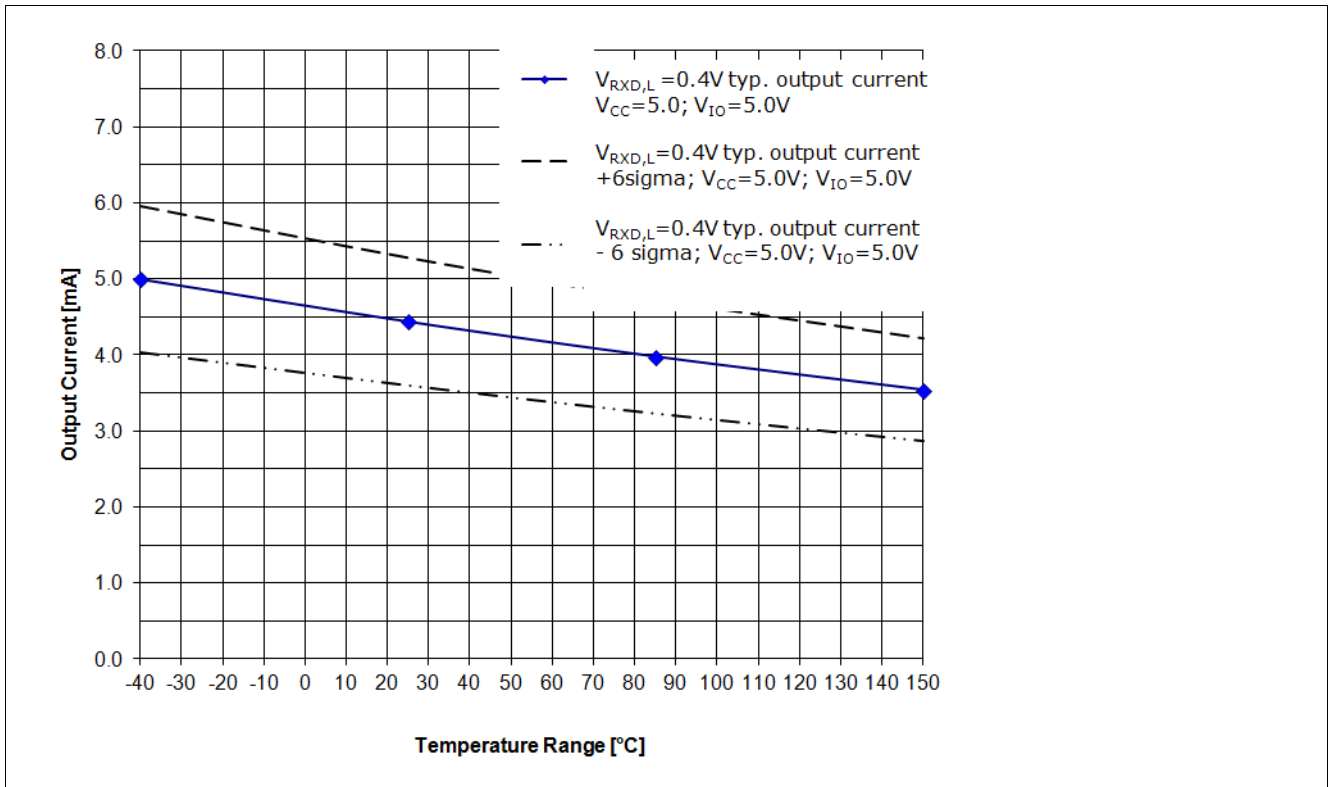

Figure 13 RxD Output driver capability for a logical “Low” signal  $V_{RxD,H}=0.4\text{ V}$ ,  $V_{CC}=5.0\text{ V}$ ,  $V_{IO}=5.0\text{ V}^1)$

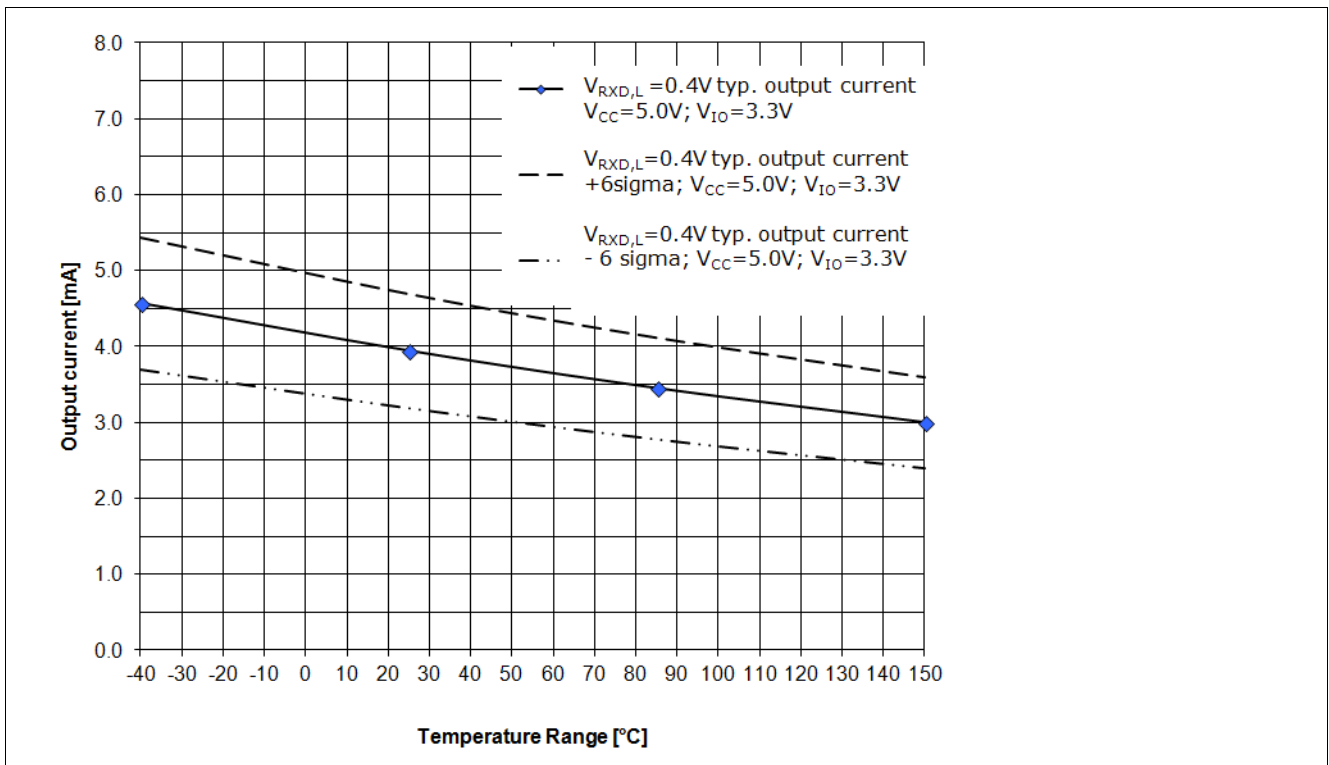

Figure 14 RxD Output driver capability for a logical “Low” signal  $V_{RxD,H}=0.4\text{ V}$ ,  $V_{CC}=5.0\text{ V}$ ,  $V_{IO}=3.3\text{ V}^1)$

1) Characteristics generated by simulation and specified by design. Production test criteria is described in [Table 6](#); Pos.: 7.1.11

### **8.3 Further Application Information**

- Please contact us for information regarding the FMEA pin.
- Existing App. Note (Title)
- For further information you may contact <http://www.infineon.com/transceiver>

## 9 Package Outlines

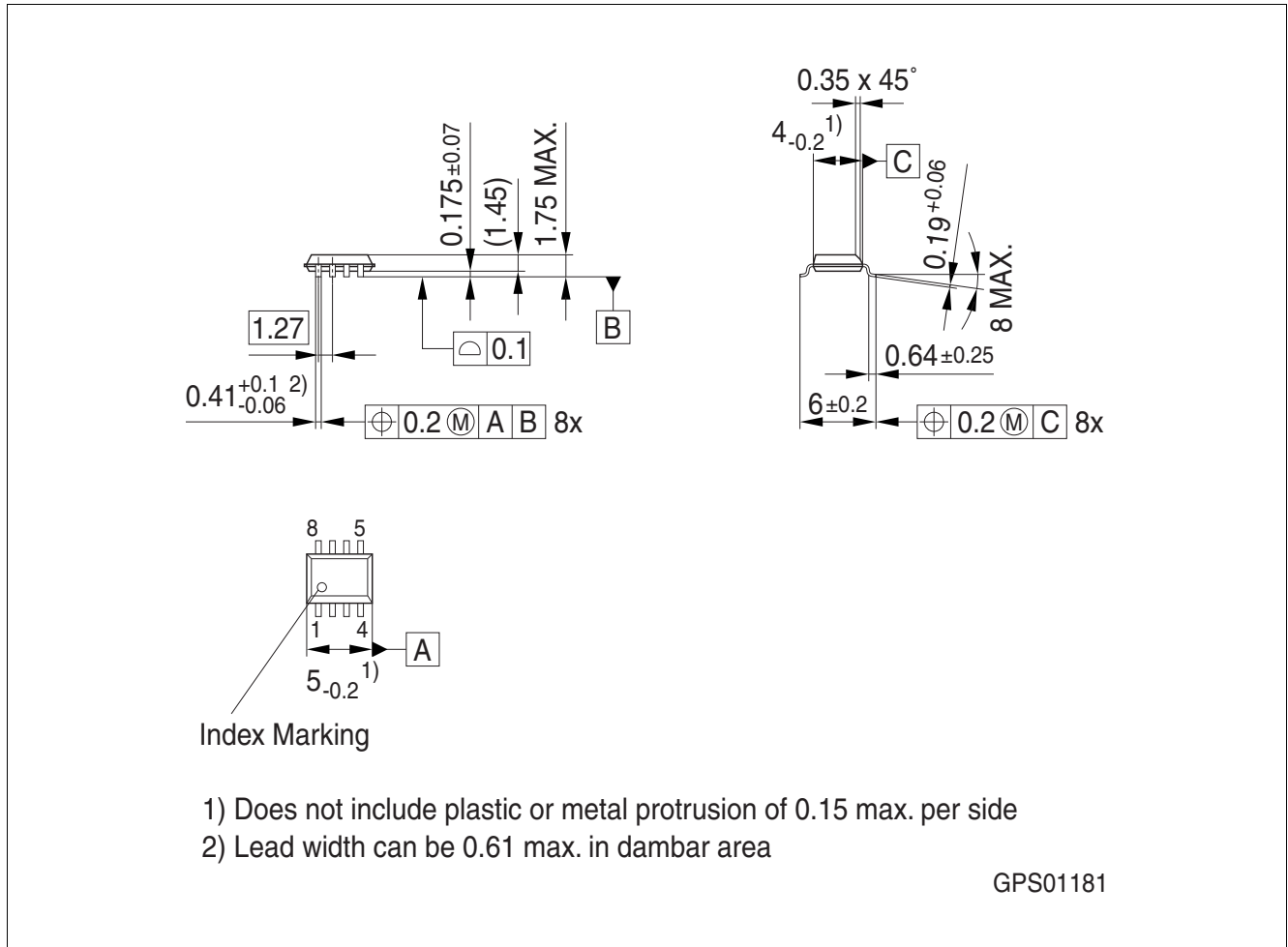

**Figure 15 PG-DSO-8 (Plastic Dual Small Outline PG-DSO-8-16)**

### Green Product (RoHS compliant)

To meet the world-wide customer requirements for environmentally friendly products and to be compliant with government regulations the device is available as a green product. Green products are RoHS-Compliant (i.e. Pb-free finish on leads and suitable for Pb-free soldering according to IPC/JEDEC J-STD-020).

## 10 Revision History

Revision	Date	Changes
1.1	2014-9-26	<p>Update from Data Sheet Rev. 1.00:</p> <ul style="list-style-type: none"> <li>• All pages: Revision and date updated. Spelling and grammar corrected.</li> <li>• Cover page: Logo and layout updated.</li> <li>• <b>Page 3, Overview:</b> Feature list updated (“Extended supply range at <math>V_{CC}</math> and <math>V_{IO}</math>”).</li> <li>• <b>Page 14, Table 4, Parameter 6.2.1:</b> Supply range updated (“4.5 V &lt; <math>V_{CC}</math> &lt; 5.5V”).</li> <li>• <b>Page 14, Table 4, Parameter 6.2.2:</b> Supply range updated (“3.0 V &lt; <math>V_{IO}</math> &lt; 5.5V”).</li> <li>• <b>Page 15, Table 6:</b> Table header updated (“4.5 V &lt; <math>V_{CC}</math> &lt; 5.5V”). Table header updated (“3.0 V &lt; <math>V_{IO}</math> &lt; 5.5V”).</li> <li>• <b>Page 16, Table 6, Parameter 7.1.29:</b> New parameter added.</li> <li>• <b>Page 16, Table 6, Parameter 7.1.30:</b> New parameter added.</li> <li>• <b>Page 16, Table 6, Parameter 7.1.31:</b> New parameter added.</li> <li>• <b>Page 16, Table 6, Parameter 7.1.34:</b> Remark added (“4.75 V &lt; <math>V_{CC}</math> &lt; 5.25V”).</li> <li>• <b>Page 16, Table 6, Parameter 7.1.35:</b> Remark added (“4.75 V &lt; <math>V_{CC}</math> &lt; 5.25V”).</li> <li>• <b>Page 16, Table 6, Parameter 7.1.36:</b> Remark added (“4.75 V &lt; <math>V_{CC}</math> &lt; 5.25V”).</li> <li>• <b>Page 20, Figure 10:</b> Picture updated.</li> <li>• <b>Page 21, Chapter 8.2:</b> Description updated, renamed the term typical input current to typical output current.</li> <li>• <b>Page 23ff, Figure 11, Figure 12, Figure 13, Figure 14:</b> Picture updated</li> <li>• <b>Page 27:</b> Revision history updated</li> </ul>
1.0	2010-09-02	Data Sheet created

**Edition 2014-10-08**

**Published by  
Infineon Technologies AG  
81726 Munich, Germany**

**© 2006 Infineon Technologies AG  
All Rights Reserved.**

### **Legal Disclaimer**

The information given in this document shall in no event be regarded as a guarantee of conditions or characteristics. With respect to any examples or hints given herein, any typical values stated herein and/or any information regarding the application of the device, Infineon Technologies hereby disclaims any and all warranties and liabilities of any kind, including without limitation, warranties of non-infringement of intellectual property rights of any third party.

### **Information**

For further information on technology, delivery terms and conditions and prices, please contact the nearest Infineon Technologies Office ([www.infineon.com](http://www.infineon.com)).

### **Warnings**

Due to technical requirements, components may contain dangerous substances. For information on the types in question, please contact the nearest Infineon Technologies Office.

Infineon Technologies components may be used in life-support devices or systems only with the express written approval of Infineon Technologies, if a failure of such components can reasonably be expected to cause the failure of that life-support device or system or to affect the safety or effectiveness of that device or system. Life support devices or systems are intended to be implanted in the human body or to support and/or maintain and sustain and/or protect human life. If they fail, it is reasonable to assume that the health of the user or other persons may be endangered.