

Description

The ISL6292EVAL2 is a complete platform for the evaluation on all datasheet specifications and functionalities. The on board 9-bit DIP switch facilitates programming charging current, setting EN input, battery thermal status, and so on. The four jumpers can set up input source selection, USB mode selection, and can be used to make other necessary connections.

The ISL6292EVAL2 board is intended to provide an evaluation platform for the 4x4mm² QFN ISL6292 package, the single-cell Li-ion battery charger.

Assembled in the center square, the components constitute a complete charger solution, demonstrating the space saving advantage of the ISL6292 in limited space applications.

LEDs connected to STATUS and FAULT pins will indicate the normal charging status or fault condition.

On board jumpers and a DIP switch accommodate different operating conditions for the charger.

Ordering Information

PART #	DESCRIPTION
ISL6292EVAL2	Evaluation Board for the 4x4 QFN Package Part.

Features

- 9-bit DIP switch for conveniently setting up charging current, battery thermal status, EN input, and so on.
- Different jumpers for input source selection, USB mode selection, and the convenience of current measurement.
- Several exposed soldering pads connected to STATUS, FAULT, TIME, EN, V2P8, IMIN and TEMP functional pins to accommodate experimental testing that need extra connections to those pins.
- Board size 3.5x2.5 square inches for the convenience of evaluation.
- Eight thermal vias in the thermal pad simulating the customers' thermal enhanced environment.

Pinout

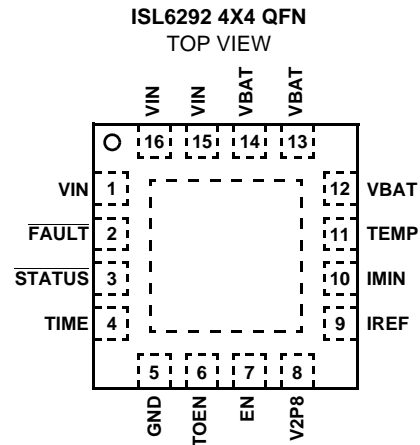

What Is Inside

The Evaluation Kit contains:

- ISL6292EVAL2 board
- The ISL6292 Data Sheet
- This ISL6292EVAL2 Application Note
- Errata (for preliminary reference only)

What Is Needed

The following instruments will be needed to perform testing:

- Power supplies:
 1. PS1: DC 20V/5A,
 2. PS2: DC (sinks current) 20V/5A, such as Agilent 6654A
- Electronic load: 20V/5A
- Multimeters
- Function generator
- Oscilloscope
- Cables and wires

Quick Setup Guide

Step 1: Switch on bit 4 and bit 7 of the Dip-switch. Leave all other bits off, see Figure 1.

DO NOT APPLY POWER UNTIL STEP 6

- Step 2:** Connect 5V on VIN.
- Step 3:** Connect 3.7V on VBAT.
- Step 4:** Connect 1.2A electronic load on VBAT.
- Step 5:** Verify that no shunts across all jumpers.
- Step 6:** Turn on Power Supplies and electronic load.
- Step 7:** Green LED should be on, indicating normal charging operation.
- Step 8:** If current meter is in series with VIN, it shall read 1A as the charging current.

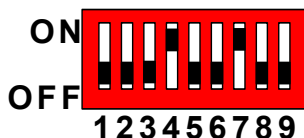

FIGURE 1. INITIAL DIP SWITCH SETTINGS

DIP Switch Settings

A 9-bit DIP switch is provided to set up voltage, current reference, end-of-charge (EOC) current, and so on. The functionality of the bits are described in Table 1.

TABLE 1. DIP SWITCH PIN DESCRIPTIONS

BIT	DESCRIPTION	ON	OFF	REMARK
1	Adjustable TIMEOUT	5 hours 50 mins	3 hours 30 mins	
2	TIMEOUT disable/enable	TIMEOUT disabled	TIMEOUT enabled	
3	Charger enable/disable	charger disabled	charger enabled	
4	IREF setting 1	Add 0.5A	I _{CHG} = 0.5A When both off	
5	IREF setting 2	Add 1A		
6	IMIN setting	100mA	50mA	
7	TEMP normal	normal		All off simulates battery removal
8	TEMP high	too hot		
9	TEMP low	too cold		

TABLE 2. JUMPER SETTINGS

JUMPER	POSITION	FUNCTION
JP1	USB TO VIN	USB input selected
	WALL CUBE TO VIN	Wall adapter input selected
JP2	Shunt Installed	connect VBAT pin to battery current meter can replace shunt
JP3	shunt installed	Battery attached to Thermistor at J2
	not installed	default
JP4	IREF and V2P8	setting USB 500mA mode
	IREF and GND	setting USB 100mA mode

Initial Board Jumper Positioning(Refer to Figure 3)

JP1 - Selects the VIN pin to be connected to either a wall adapter, or to a USB connector. If the J1 connector is being used, a shunt must be installed across 'WALL CUBE TO VIN', or if the J3 (USB) connector is being used, a shunt must be installed across 'USB TO VIN'. J1, J3 and JP1 can be ignored if the power supply is connected directly to VIN test point, which is directly connected to VIN pin of the IC. A current meter, to measure the input current, can replace the shunt mentioned above.

JP2 - Can connect the VBAT pin to the battery. If the J2 connector is being used, a shunt must be installed across JP2. In this case, a current meter can also replace the shunt to measure the VBAT current.

JP3 - Can connect the TEMP pin to the battery. Usually no shunt is needed for JP3, as the Eval board can simulate various battery thermal conditions. Only when a battery with a attached thermistor is applied on J2 does it become necessary to install a shunt across JP3, simultaneously turning off bits 7, 8, and 9 on the DIP switch.

JP4 - Selects USB modes; a shunt across IREF and V2P8 will set USB 500mA mode, a shunt across IREF and GND will set USB 100mA mode. When the charge current is programmed by the resistors connected to IREF pin, no shunt should be installed on JP4.

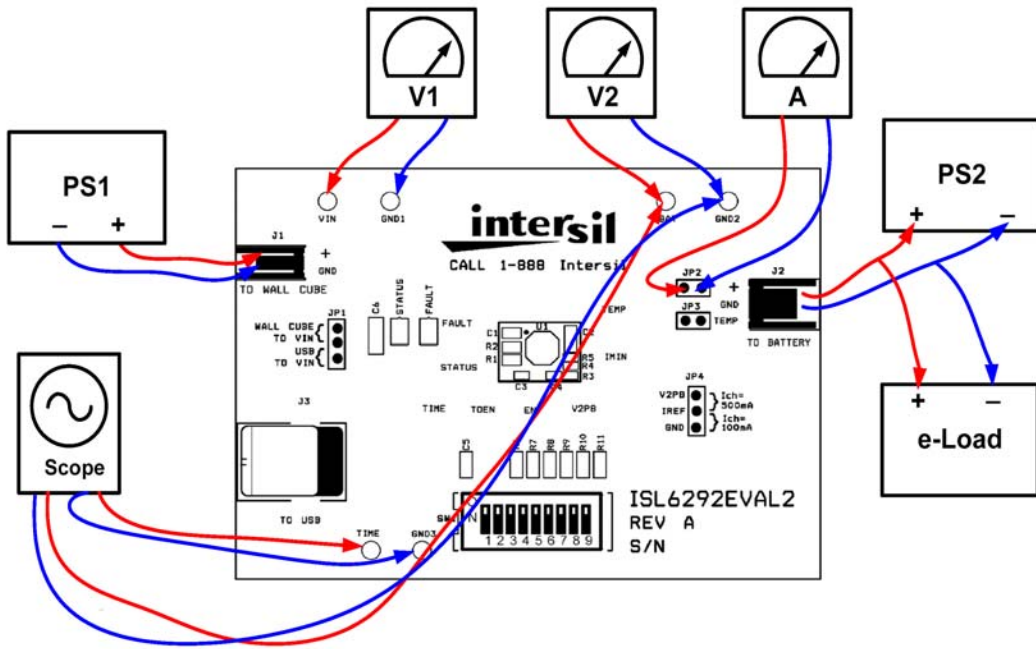

FIGURE 2. CONNECTION OF INSTRUMENTS

Board Layout Information

Schematics of PCB Board

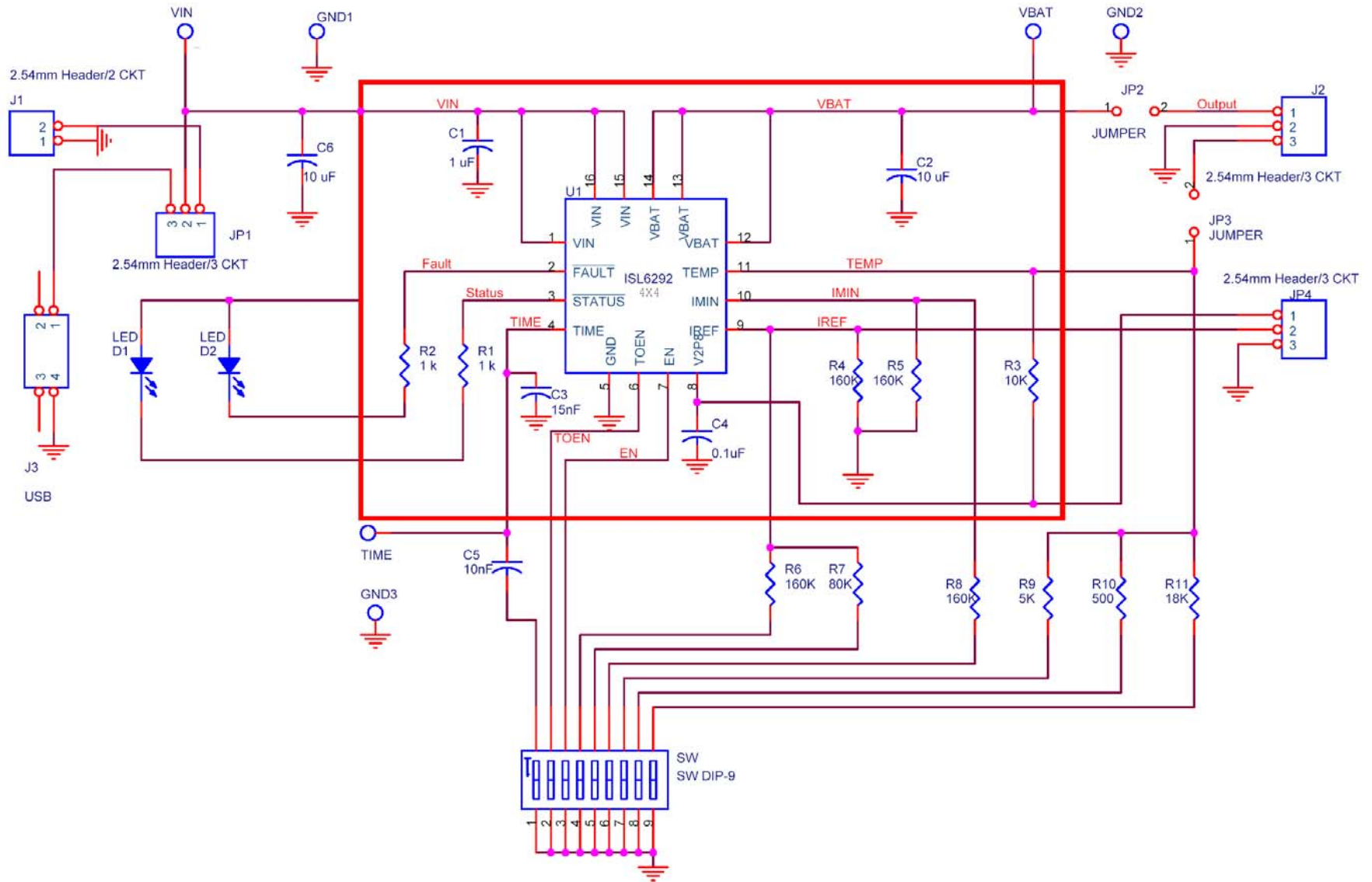

FIGURE 3. BOARD LAYOUT INFORMATION SCHEMATIC

Bill Of Materials

BOM FOR ISL6292EVAL2

ITEM	QUANTITY	REFERENCE	PART DESCRIPTION	PCB FOOTPRINT	PART NUMBER	VENDOR
1	1	C1	1 μ F/10V, X5R Ceramic Cap	0603	C1608X5R1A105K	TDK
2	1	C2	10 μ F/6.3V Tantalum Cap	2.05x1.3x1.2	TAJR106M006	AVX
3	1	C3	15nF/16V, X7R Ceramic Cap	0402	C1005X7R1C153K	TDK
4	1	C4	0.1 μ F/16V, Y5V Ceramic Cap	0402	C1005Y5V1C104ZT	TDK
5	1	C5	10nF/16V, X7R Ceramic Cap	0402	C1005X7R1C103K	TDK
6	1	C6	10 μ F/16V, Tantalum Cap	3.2x1.6x1.6	TAJA106M016	AVX
7	1	D1	Green LED	0805	67-1553-1-ND	DigiKey
8	1	D2	Red LED	0805	67-1552-1-ND	DigiKey
9	2	R1, R2	1k, 5%	0603		Various
10	1	R3	10k, 1%	0402		Various
11	2	R4, R5	160k, 1%	0402		Various
12	1	R6	160k, 1%	0805		Various
13	1	R7	80k, 1%	0805		Various
14	1	R8	160k, 1%	0805		Various
15	1	R9	5k, 1%	0805		Various
16	1	R10	500, 1%	0805		Various
17	1	R11	18k, 1%	0805		Various
18	1	J1	2.54mm Male Header, 2ckt (R/A)		A23879-ND	DigiKey
19	1	J2	2.54mm Male Header, 3ckt (R/A)		A23880-ND	DigiKey
20	2	JP1, JP4	2.54mm Male Header, 3ckt		WM6403-ND	DigiKey
21	2	JP2, JP3	2.54mm Male Header, 2ckt		WM6402-ND	DigiKey
22	1	J3	USB Receptacle, B Type		787780-1-ND	DigiKey
23	1	SW1	DIP Switch, 9 POS, SMT		CKN1323-ND	DigiKey
24	1	U1	Single-Cell Li-ion Battery Charger	16-pin, 3x3 QFN	ISL6292	Intersil
25	6	VIN, VBAT, TIME, GND1, GND2, GND3	Test Point		5002K-ND	DigiKey

PCB Layout

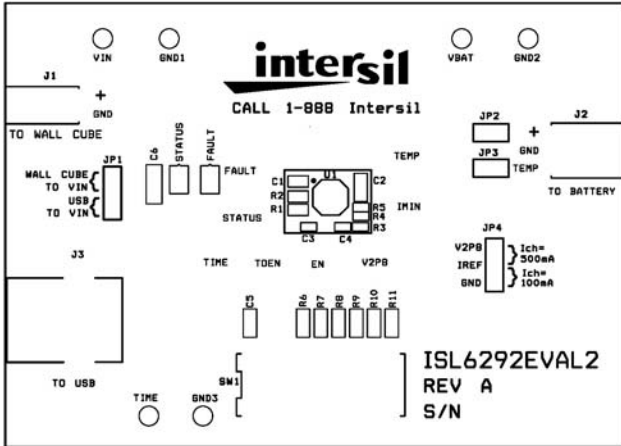

SILK LAYER

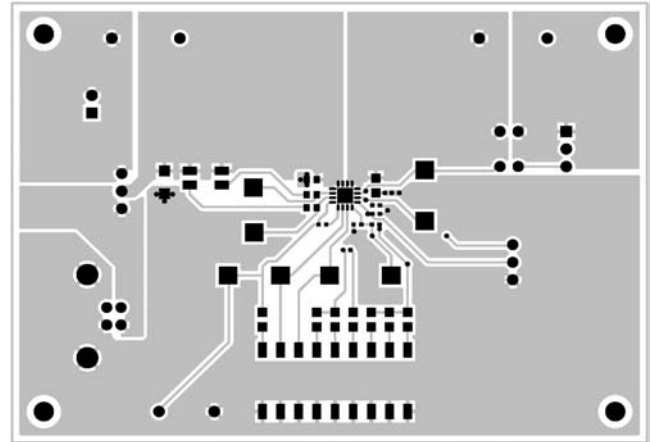

TOP (LAYER 1, SIGNAL)

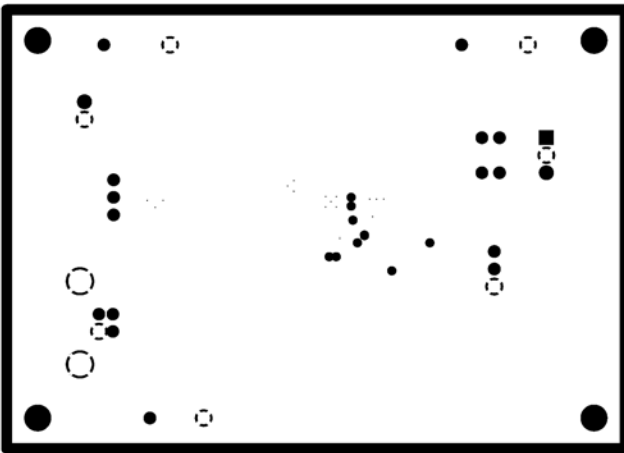

INTERNAL (LAYER 2, GND)

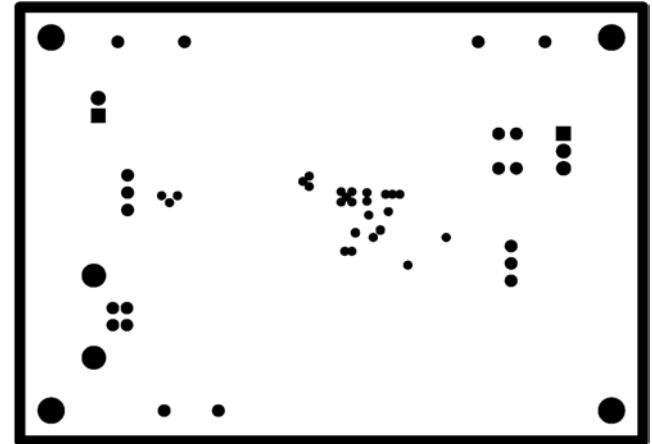

INTERNAL (LAYER 3, FLOATING)

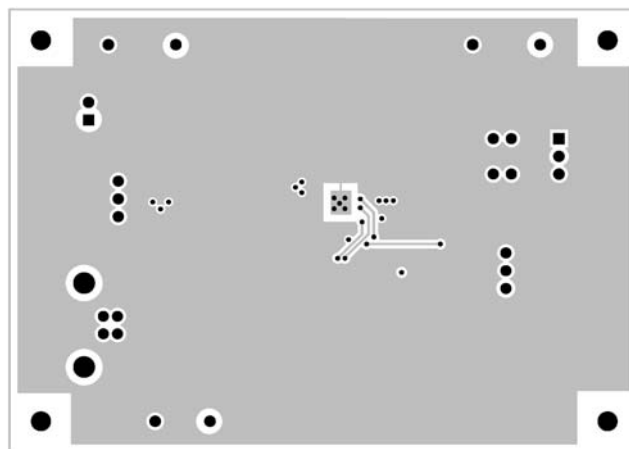

BOTTOM (LAYER 4, GND)

All Intersil products are manufactured, assembled and tested utilizing ISO9000 quality systems. Intersil Corporation's quality certifications can be viewed at www.intersil.com/design/quality

Intersil products are sold by description only. Intersil Corporation reserves the right to make changes in circuit design, software and/or specifications at any time without notice. Accordingly, the reader is cautioned to verify that data sheets are current before placing orders. Information furnished by Intersil is believed to be accurate and reliable. However, no responsibility is assumed by Intersil or its subsidiaries for its use; nor for any infringements of patents or other rights of third parties which may result from its use. No license is granted by implication or otherwise under any patent or patent rights of Intersil or its subsidiaries.

For information regarding Intersil Corporation and its products, see www.intersil.com