

ABU2518 Data Sheet

5 ~ 1400 MHz CATV Push-pull Amplifier MMIC

1. Product Overview

1.1 General Description

ABU2518, a wide-band linear push-pull amplifier MMIC, has high linearity and low noise over a wide range of 5 ~ 1400 MHz, being suitable to low return loss in the reverse (5 ~ 300 MHz) and flat gain in the forward path (50 ~ 1400 MHz) in the fiber receiver, distribution amplifiers and drop amplifiers of CATV. The gain slope is adjustable with the off-chip feedback circuit components. The amplifier is available in an SOIC8 package and passes through the stringent 100% DC & RF test in an automated test handler.

1.2 Features

- Low-noise and high linearity
- Wide-band CATV application at 5 ~ 1400 MHz
- 75 Ω input & output matching
- Robust under hard operation conditions
- 20.3 dB gain at 50 MHz
- CSO of 71 dBc, CTB of 60 dBc
@ Pout = 103 dB μ V flat for NTSC 77 channels, device voltage = +5 V
- Single supply: +5 V

1.3 Applications

- CATV Reverse at 5 ~ 300 MHz
- CATV Forward at 50 ~ 1400 MHz
- HFC Nodes, Head-end Equipment

1.4 Package Profile & RoHS Compliance

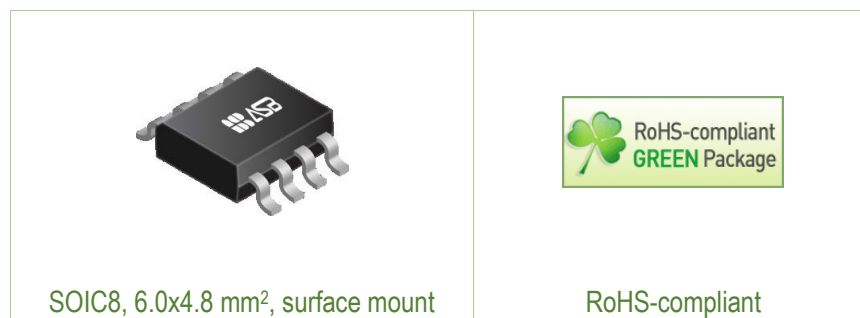

2. Summary on Product Performances

2.1 Typical Performance

Supply voltage = +5 V, T_A = +25 °C, Z_O = 75 Ω.

Parameter	Typical			Unit
Frequency	5	50	300	MHz
Noise Figure	3.6	2.2	2.2	dB
Gain	20.0	20.3	20.1	dB
S11	-20	-20	-20	dB
S22	-18	-20	-19	dB
Output IP3	40 ¹⁾	42 ²⁾	41 ²⁾	dBm
Output IP2 ³⁾	64	71	69	dBm
Output P1dB	25	26	26	dBm
CSO	71 ⁴⁾			dBc
CTB	60 ⁴⁾			dBc
Current	275			mA
Device Voltage	+5			V

- 1) OIP3 is measured with two tones at an output power of +10 dBm/tone separated by 1 MHz.
 2) OIP3 is measured with two tones at an output power of +10 dBm/tone separated by 6 MHz.
 3) OIP2 is measured with two tones at an output power of +10 dBm/tone separated by 6 MHz.
 4) CSO & CTB measured at P_{out} = 103 dBμV flat for NTSC 77 channels.

2.2 Product Specification

Supply voltage = +5 V, T_A = +25 °C, Z_O = 75 Ω.

Parameter	Min	Typ	Max	Unit
Frequency		50		MHz
Noise Figure		2.2		dB
Gain	19.3	20.3	21.3	dB
S11		-20		dB
S22		-20		dB
Output IP3 ¹⁾		42		dBm
Output IP2 ²⁾		71		dBm
Output P1dB		26		dBm
Current	235	275	315	mA
Device Voltage		+5		V

- 1) OIP3 is measured with two tones at an output power of +10 dBm/tone separated by 6 MHz.
 2) OIP2 is measured with two tones at an output power of +10 dBm/tone separated by 6 MHz.

2.3 Pin Configuration

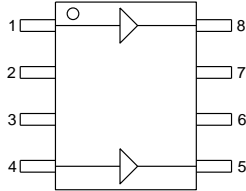
Pin	Description	Simplified Outline
1,4	RF_IN	
2, 3, 6, 7	NC or GND	
5, 8	RF_OUT & Bias	

2.4 Absolute Maximum Ratings, $T_A = +25\text{ }^\circ\text{C}$

Parameters	Max. Ratings
Operating Case Temperature	-40 to +85 $^\circ\text{C}$
Storage Temperature	-40 to +150 $^\circ\text{C}$
Device Voltage	+6 V
Device Current	360 mA
Power Dissipation	+1.8 W
Junction Temperature	+150 $^\circ\text{C}$
Input RF Power (CW, 75 Ω matched)	+26 dBm

Note: operation of this device in excess of any of these limits may cause permanent damage.

2.5 Thermal Resistance

Symbol	Description	Typ	Unit
R_{th}	Thermal resistance from junction to lead	32	$^\circ\text{C/W}$

2.6 ESD Classification & Moisture Sensitivity Level

ESD Classification

HBM Class 1A

CAUTION: Gallium Arsenide Integrated Circuits are sensitive to electrostatic discharge (ESD) and can be damaged by static electricity. Proper ESD control techniques should be used when handling these devices.

Moisture Sensitivity Level

MSL 3 at 260 $^\circ\text{C}$ reflow

(Intentionally Blanked)

3. Application: 5 ~ 300 MHz ($V_{\text{device}} = +5 \text{ V}$)

3.1 Application Circuit & Evaluation Board

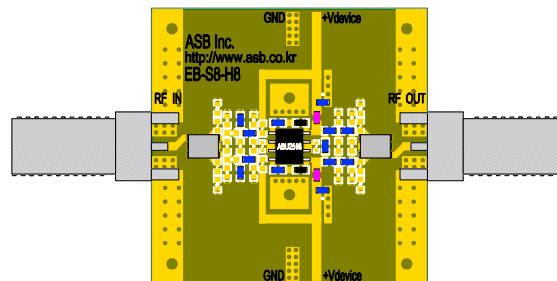
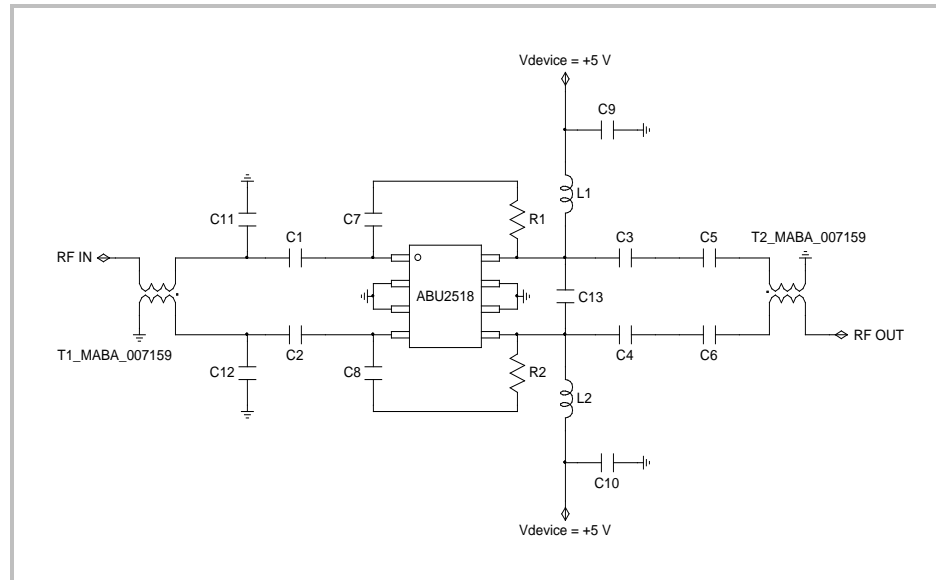

PCB Information	
Material	FR4
Thickness (mm)	0.8
Size (mm)	40x40
EB No.	EB-S8-H8

Bill of Material

Symbol	Value	Size	Description	Manufacturer
ABU2518	-	-	MMIC Amplifier	ASB
C1, C2, C3, C4, C5, C6	1 μF	0603	DC blocking capacitor	Murata
C7, C8	1 μF	0603	Feedback capacitor	Murata
C9, C10	10 μF	0805	Decoupling capacitor	Murata
C11, C12	1.5 pF	0603	Matching capacitor	Murata
C13	1.2 pF	0603	Matching capacitor	Murata
L1, L2	22 μH	1206	RF choke inductor	Murata
R1, R2	510 Ω	0603	Feedback resistor	Samsung
T1, T2	1:1	-	Transformer balun	MACOM

3.2 Performance Table

Supply voltage = +5 V, T_A = +25 °C, Z₀ = 75 Ω.

Parameter	Typical			Unit
Frequency	5	50	300	MHz
Noise Figure	3.6	2.2	2.2	dB
Gain	20.0	20.3	20.1	dB
S11	-20	-20	-20	dB
S22	-18	-20	-19	dB
Output IP3	40 ¹⁾	42 ²⁾	41 ²⁾	dBm
Output IP2 ³⁾	64	71	69	dBm
Output P1dB	25	26	26	dBm
CSO	71 ⁴⁾			dBc
CTB	60 ⁴⁾			dBc
Current	257			mA
Device Voltage	+5			V

1) OIP3 is measured with two tones at an output power of +10 dBm/tone separated by 1 MHz.

2) OIP3 is measured with two tones at an output power of +10 dBm/tone separated by 6 MHz.

3) OIP2 is measured with two tones at an output power of +10 dBm/tone separated by 6 MHz.

4) CSO & CTB measured at P_{out} = 103 dBμV flat for NTSC 77 channels.

*Note : P_{out} is 105 dBμV @ flat ch. and 108 dBμV @ 9 dB tilt for CENELEC 42 ch. at CSO, CTB > 60 dBc.

3.3 Plot of S-parameter & Stability Factor

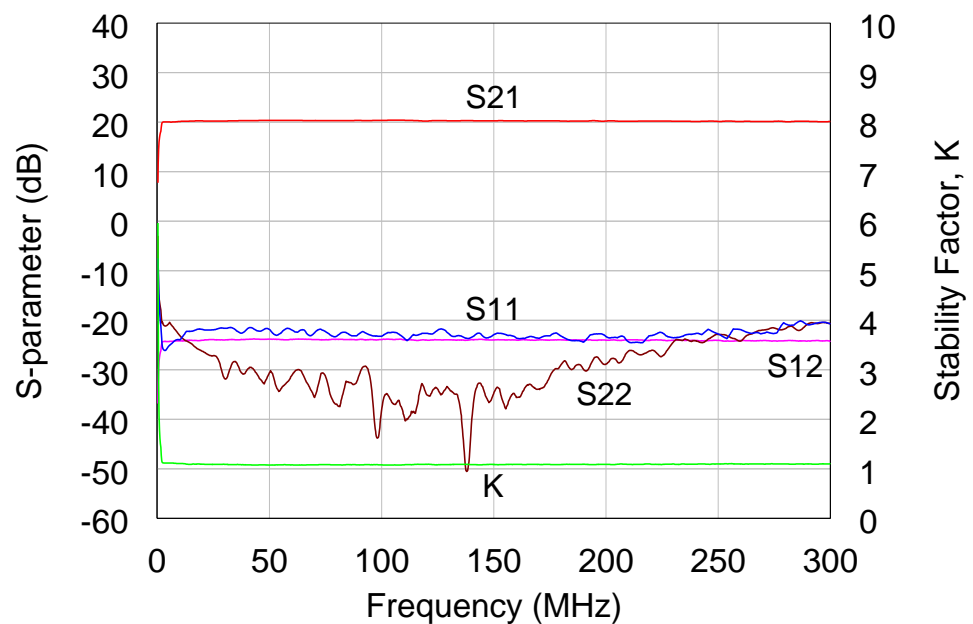

3.4 Plots of Noise Figure and Performances with Temperature

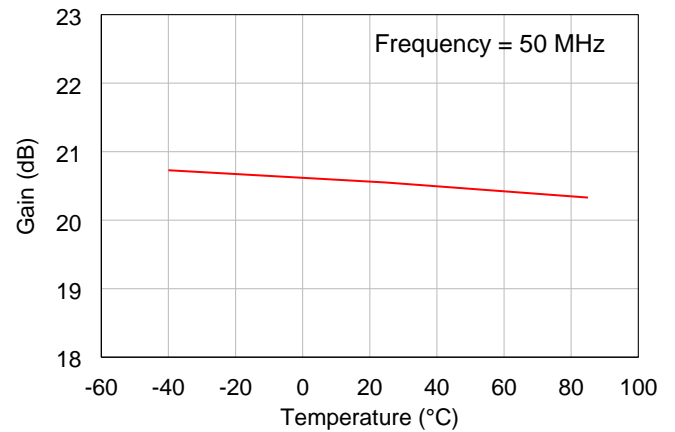
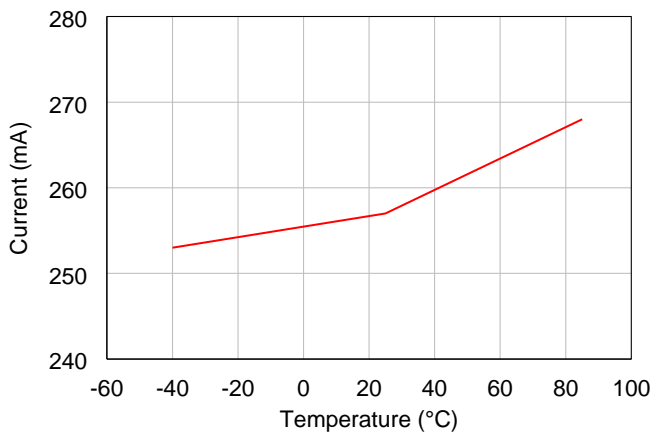
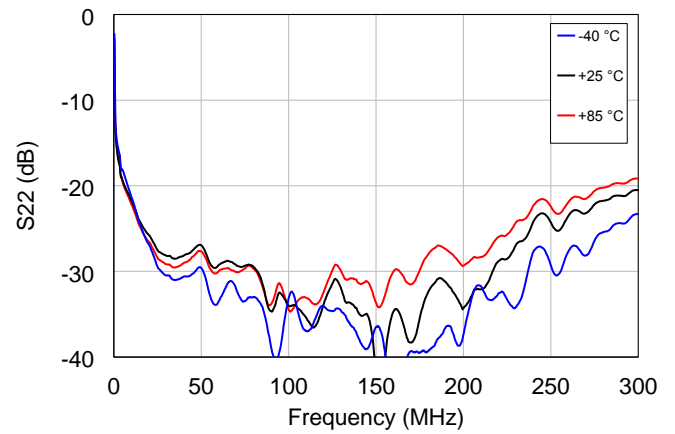
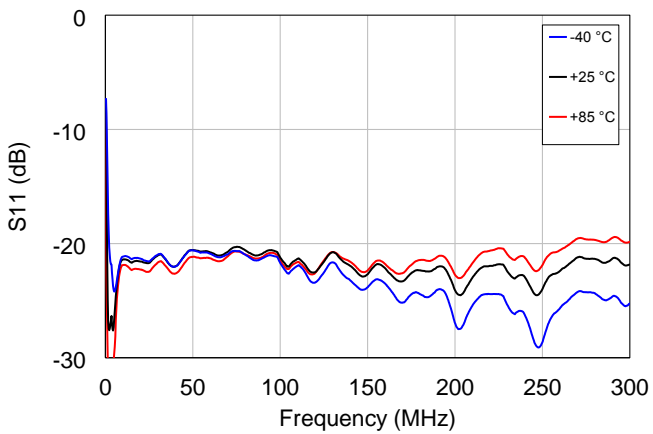
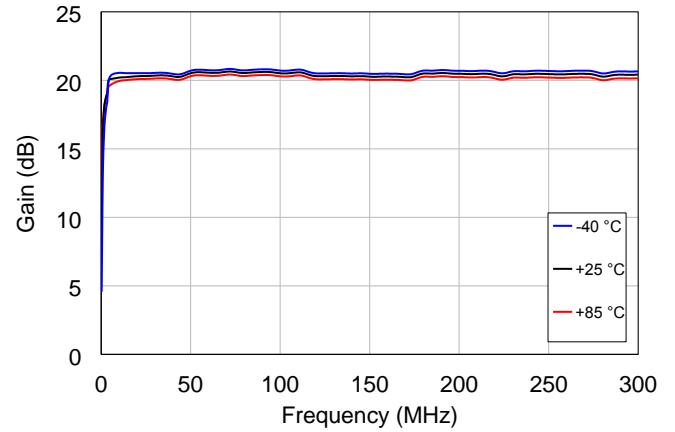
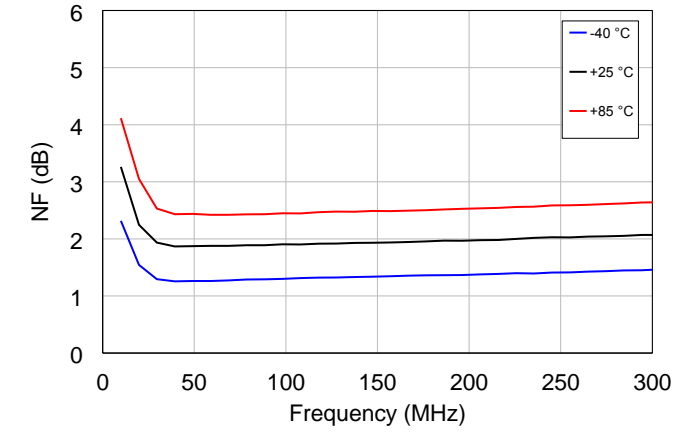

4. Application: 50 ~ 1200 MHz ($V_{device} = +5 V$)

4.1 Application Circuit & Evaluation Board

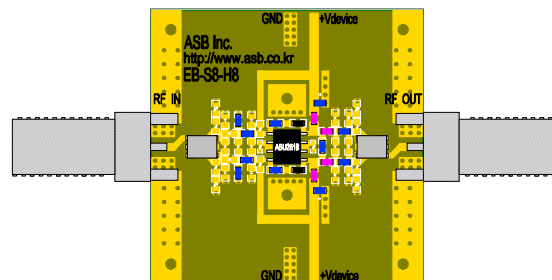
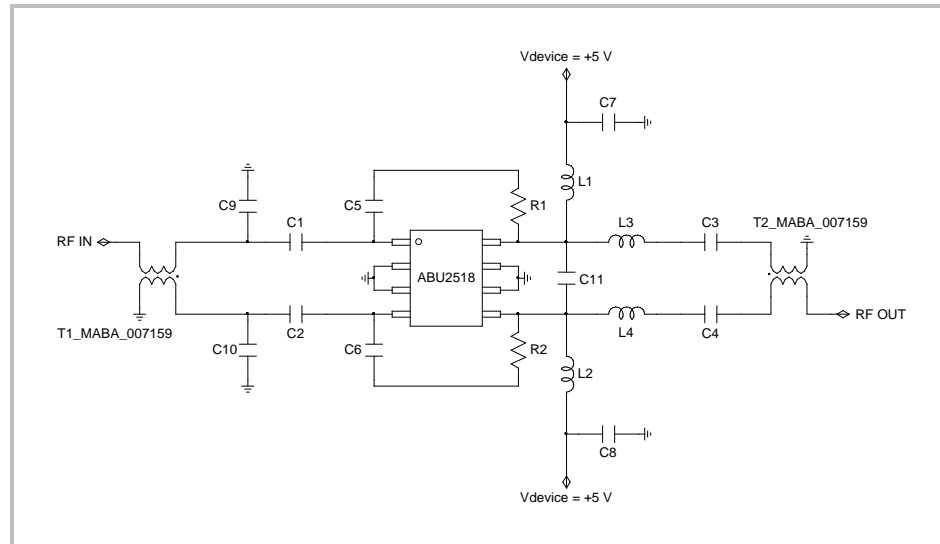

PCB Information	
Material	FR4
Thickness (mm)	0.8
Size (mm)	40x40
EB No.	EB-S8-H8

Bill of Material

Symbol	Value	Size	Description	Manufacturer
ABU2518	-	-	MMIC Amplifier	ASB
C1, C2, C3, C4	1 nF	0603	DC blocking capacitor	Murata
C5, C6	10 nF	0603	Feedback capacitor	Murata
C7, C8	10 μ F	0805	Decoupling capacitor	Murata
C9, C10	1.5 pF	0603	Matching capacitor	Murata
C11	1.5 pF	0603	Matching capacitor	Murata
L1, L2	1 μ H	1206	RF choke inductor	Murata
L3, L4	2.7 nH	0603	Matching inductor	Murata
R1, R2	430 Ω	0603	Feedback resistor	Samsung
T1, T2	1:1	-	Transformer balun	MACOM

4.2 Performance Table

Supply voltage = +5 V, $T_A = +25\text{ }^\circ\text{C}$, $Z_0 = 75\ \Omega$.

Parameter	Typical			Unit
Frequency	50	500	1200	MHz
Noise Figure	2.4	2.5	2.7	dB
Gain	19.3	19.2	18.7	dB
S11	-16	-19	-18	dB
S22	-18	-17	-16	dB
Output IP3 ¹⁾	42	41	39	dBm
Output IP2 ²⁾	63			dBm
Output P1dB	26	26	25	dBm
CSO	71 ³⁾			dBc
CTB	60 ³⁾			dBc
Current	275			mA
Device Voltage	+5			V

1) OIP3 is measured with two tones at an output power of +10 dBm/tone separated by 6 MHz.

2) OIP2 is measured with two tones($F_1 = 400\text{ MHz} + F_2 = 450\text{ MHz}$) at an output power of +10 dBm/tone.

3) CSO & CTB measured at $P_{out} = 103\text{ dB}\mu\text{V}$ flat for NTSC 77 channels.

*Note : P_{out} is $105\text{ dB}\mu\text{V}$ @ flat ch. and $108\text{ dB}\mu\text{V}$ @ 9 dB tilt for CENELEC 42 ch. at CSO, CTB > 60 dBc.

4.3 Plot of S-parameter & Stability Factor

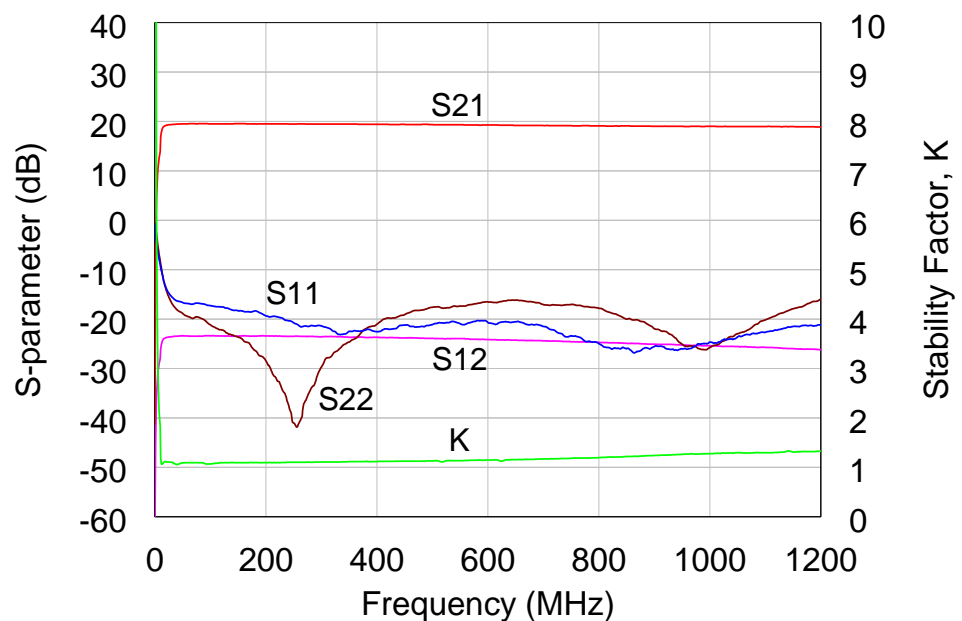

5. Application: 50 ~ 1400 MHz ($V_{device} = +5 V$)

5.1 Application Circuit & Evaluation Board

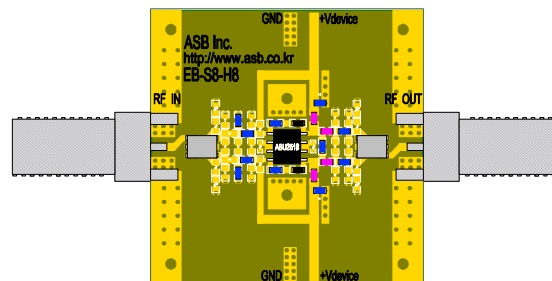
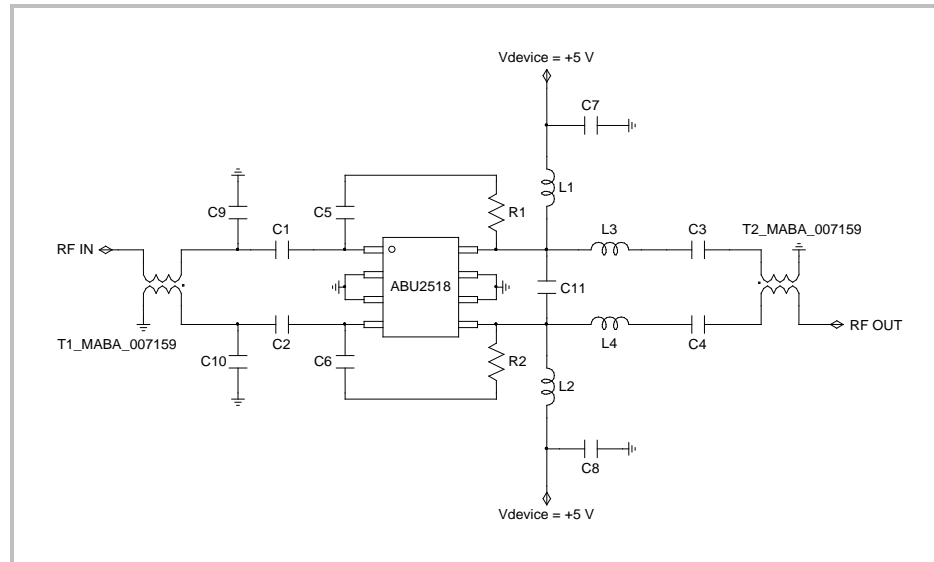

PCB Information

Material	FR4
Thickness (mm)	0.8
Size (mm)	40x40
EB No.	EB-S8-H8

Bill of Material

Symbol	Value	Size	Description	Manufacturer
ABU2518	-	-	MMIC Amplifier	ASB
C1, C2, C3, C4	1 nF	0603	DC blocking capacitor	Murata
C5, C6	10 nF	0603	Feedback capacitor	Murata
C7, C8	10 μ F	0805	Decoupling capacitor	Murata
C9, C10	1.8 pF	0603	Matching capacitor	Murata
C11	1.5 pF	0603	Matching capacitor	Murata
L1, L2	1 μ H	1206	RF choke inductor	Murata
L3, L4	2.7 nH	0603	Matching inductor	Murata
R1, R2	430 Ω	0603	Feedback resistor	Samsung
T1, T2	1:1	-	Transformer balun	MACOM

5.2 Performance Table

Supply voltage = +5 V, $T_A = +25\text{ }^\circ\text{C}$, $Z_O = 75\ \Omega$.

Parameter	Typical				Unit
Frequency	50	500	1200	1400	MHz
Noise Figure	2.4	2.5	2.7	3.3	dB
Gain	19.2	19.1	18.8	18.7	dB
S11	-15	-18	-15	-17	dB
S22	-16	-15	-20	-16	dB
Output IP3 ¹⁾	42	42	41	40	dBm
Output IP2 ²⁾	63				dBm
Output P1dB	26	26	25	25	dBm
Current	275				mA
Device Voltage	+5				V

1) OIP3 is measured with two tones at an output power of +10 dBm/tone separated by 6 MHz.

2) OIP2 is measured with two tones(F1 = 400 MHz + F2 = 450 MHz) at an output power of +10 dBm/tone.

5.3 Plot of S-parameter & Stability Factor

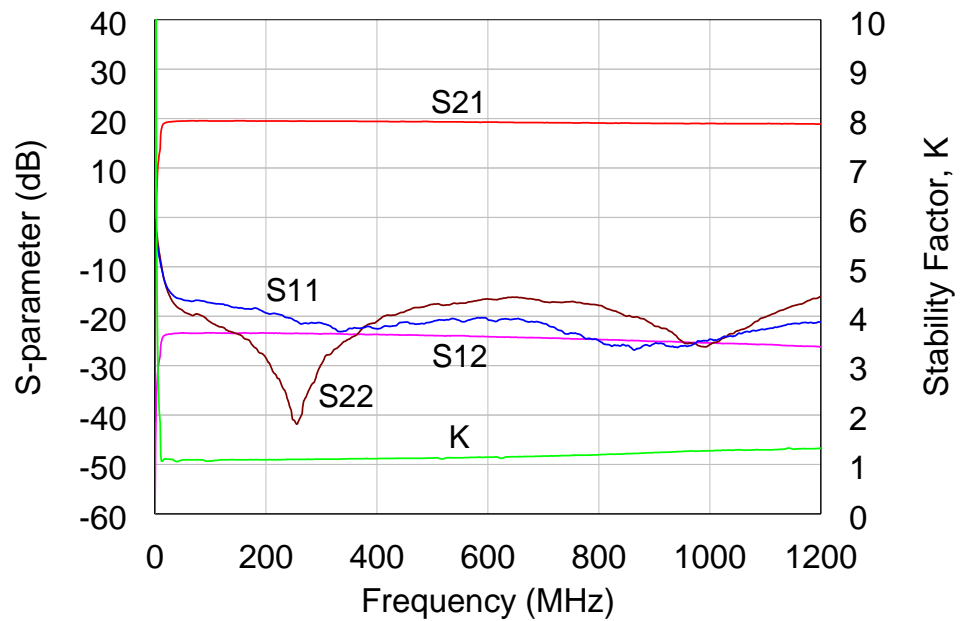

6. Package Outline (SOIC8)

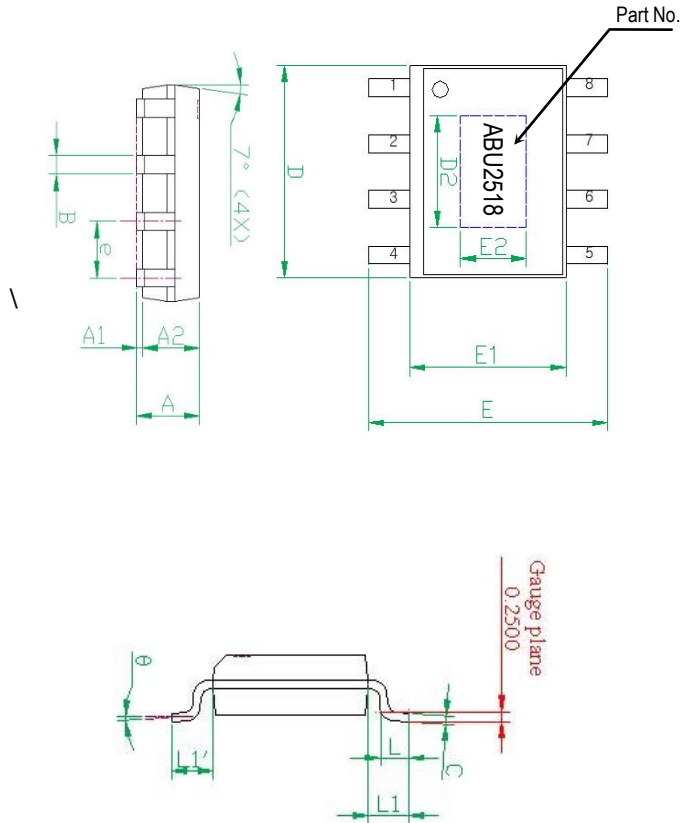

Symbols	Dimensions (In mm)		
	MIN	NOM	MAX
A	1.40	1.50	1.60
A1	0.00	---	0.10
A2	---	1.45	---
B	0.33	---	0.51
C	0.19	---	0.25
D	4.80	---	5.00
D2	3.20	3.30	3.40
E	5.80	6.00	6.20
E1	3.80	3.90	4.00
E2	2.30	2.40	2.50
e	---	1.27	---
L	0.40	---	1.27
y	---	---	0.10
θ	0°	---	8°
L1-L1'	---	---	0.12
L1		1.04REF	

7. Surface Mount Recommendation (In mm)

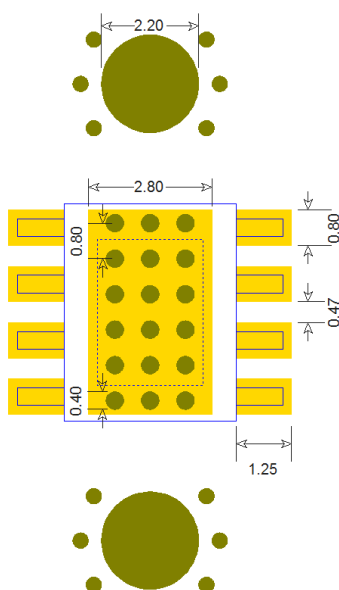

NOTE

1. Add as much copper as possible to inner and outer layers near the part to ensure optimal thermal performance.
2. To ensure reliable operation, device ground paddle-to-ground pad soldering is critical.
3. Add mounting screws near the part to fasten the board to a heat sinker. Ensure that the ground & thermal via region contacts the heat sinker.
4. A proper heat dissipation path underneath the area of the PCB for the mounted device is strictly required for proper thermal operation. Damage to the device can result from inappropriate heat dissipation.

8. Recommended Soldering Reflow Profile

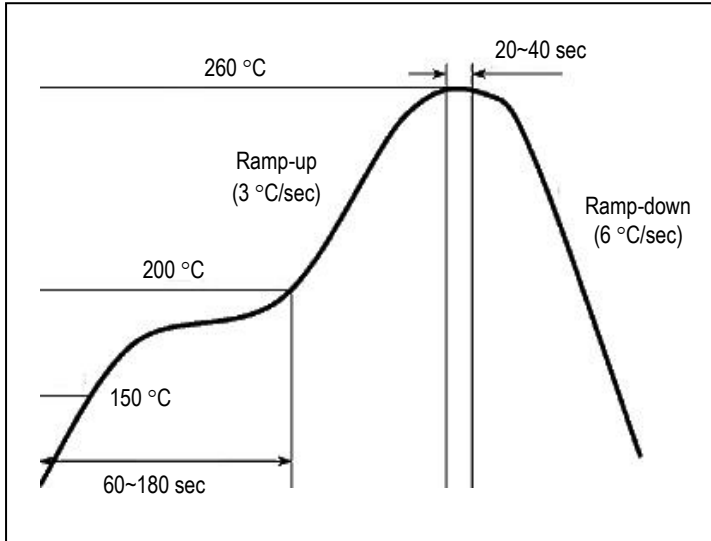

(End of Datasheet)

Copyright ©2017 ASB Inc. All rights reserved. Specifications subject to change without notice. ASB assumes no responsibility for any errors which may appear in this datasheet. No part of the datasheet may be copied or reproduced in any form or by any means without the prior written consent of ASB.