

## 1.5A Positive Voltage Regulator

### ■ GENERAL DESCRIPTION

The XB1086 is a series of low dropout positive voltage regulators with a high output current capability of 1.5A.

Stable output can be maintained by using 10 μF (C<sub>IN</sub>) and 22 μF (C<sub>L</sub>) of tantalum capacitors.

The XB1086P series is available in the fixed voltage types of 1.5V, 1.8V, 2.5V, 3.3V, and 5.0V. The XB1086K is also available as a voltage adjustable type which can set the output voltage with only two external resistors. With an over current and thermal protection circuit built-in, the IC is disabled for protection when an output current reaches limit current or junction temperature increases up to limit temperature.

The XB1086 series is available in TO-252 package.

### ■ APPLICATIONS

- High efficiency linear regulators
- Battery chargers
- DVD drives
- Set top boxes
- Various battery drive equipment

### ■ FEATURES

- Maximum Output Current** : More than 1.5A (within Pd)
- Maximum Operating Voltage** : 15V
- Output Voltage** : 1.5V, 1.8V, 2.5V, 3.3V, 5.0V (XB1086P), Externally Set (XB1086K / Reference Voltage 1.25V (TYP.))
- Output Voltage Accuracy** : ±1% (T<sub>j</sub>=25°C)
- Dropout Voltage** : 1.3V @ I<sub>OUT</sub>=1.5A (TYP.)
- Line Regulation** : 0.015% (TYP.) <ADJ>
- Load Regulation** : 0.1% (TYP.) <ADJ>
- Reference Voltage Pin Current**: Less than 120 μA <ADJ>
- Overcurrent Protection Circuit Built-In**
- Thermal Protection Circuit Built-In**
- Package** : TO-252
- Environmentally Friendly** : EU RoHS Compliant

### ■ TYPICAL APPLICATION CIRCUITS

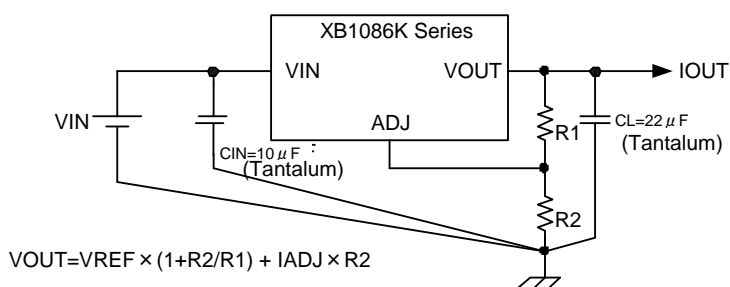
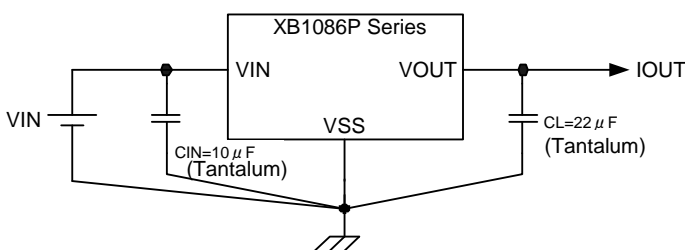

### ■ TYPICAL PERFORMANCE CHARACTERISTICS

- Output Voltage vs. Output Current

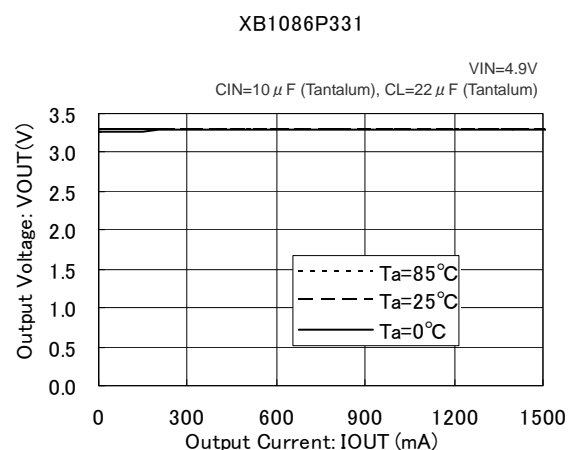

## PIN CONFIGURATION

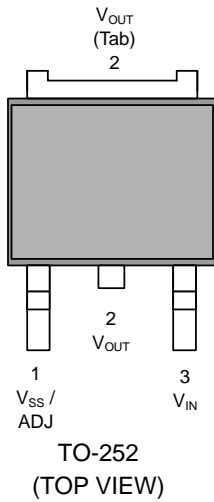

## PIN ASSIGNMENT

PIN NUMBER	PIN NAME	FUNCTIONS
TO-252		
1	$V_{SS} / ADJ$	Ground / Reference Voltage
2	$V_{OUT}$	Output
3	$V_{IN}$	Input

## PRODUCT CLASSIFICATION

### Ordering Information

XB1086①②③④⑤⑥-⑦<sup>(\*)</sup>

DESIGNATOR	ITEM	SYMBOL	DESCRIPTION
①	Type of Regulators	P	Fixed $V_{OUT}$
		K	Adjustable (Externally Set)
②③④	Output Voltage and Output Voltage Accuracy	151	$V_{OUT}=1.5V (\pm 1\%)$
		181	$V_{OUT}=1.8V (\pm 1\%)$
		251	$V_{OUT}=2.5V (\pm 1\%)$
		331	$V_{OUT}=3.3V (\pm 1\%)$
		501	$V_{OUT}=5.1V (\pm 1\%)$
		12B	$V_{REF}=1.25V (\pm 1\%)$
⑤⑥-⑦	Package (Order Unit)	JR	TO-252 (2,500/Reel)
		JR-G	TO-252 (2,500/Reel)

<sup>(\*)</sup> The "-G" suffix denotes Halogen and Antimony free as well as being fully RoHS compliant.

## ■ BLOCK DIAGRAM

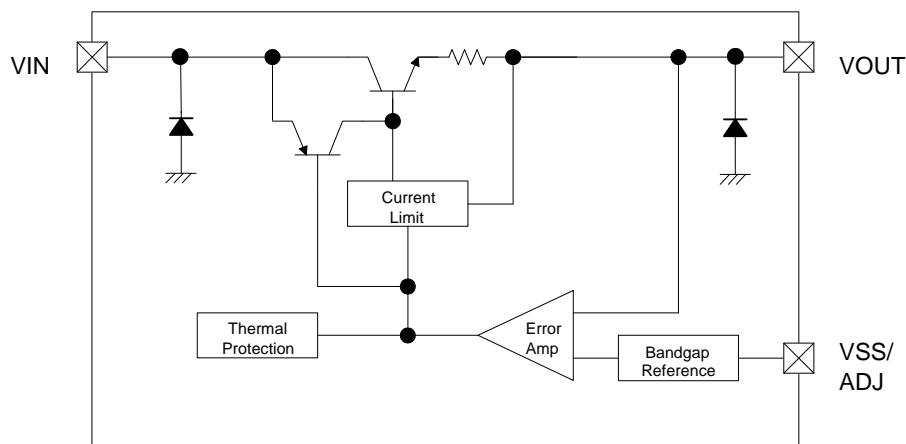

\*Diodes inside the circuit are ESD protection diodes.

## ■ ABSOLUTE MAXIMUM RATINGS

PARAMETER	SYMBOL	RATINGS	UNIT
Input Voltage	$V_{IN}$	18	V
Power Dissipation	$P_d$	1300 <sup>(*2)</sup>	mW
Operating Junction Temperature	$T_j$	125	°C
Storage Temperature	$T_{stg}$	- 55 ~ 125	°C

Note:

\*1: Stresses greater than those listed under the above ratings may cause permanent damage to the device.

\*2: The rating of the power dissipation is determined when mounted on the PCB.

## ELECTRICAL CHARACTERISTICS

XB1086PxxxJ

T<sub>j</sub>= 25°C unless otherwise specified

PARAMETER	SYMBOL	CONDITIONS	MIN.	TYP.	MAX.	UNIT	CIRCUIT
Output Voltage	V <sub>OUT</sub> (1.5V)	V <sub>IN</sub> =3.5V, I <sub>OUT</sub> =10mA	1.485	1.5	1.515	V	①
		O.T. (*1)	1.47	-	1.53		
	V <sub>OUT</sub> (1.8V)	V <sub>IN</sub> =3.8V, I <sub>OUT</sub> =10mA	1.782	1.8	1.818	V	①
		O.T. (*1)	1.746	-	1.854		
	V <sub>OUT</sub> (2.5V)	V <sub>IN</sub> =4.5V, I <sub>OUT</sub> =10mA	2.475	2.500	2.525	V	①
	O.T. (*1)	2.45	-	2.55			
V <sub>OUT</sub> (3.3V)	V <sub>IN</sub> =5.0V, I <sub>OUT</sub> =10mA	3.267	3.300	3.333	V	①	
	O.T. (*1)	3.235	-	3.366			
V <sub>OUT</sub> (5.0V)	V <sub>IN</sub> =7.0V, I <sub>OUT</sub> =10mA	4.95	5	5.05	V	①	
	O.T. (*1)	4.9	-	5.1			
Line Regulation	ΔV <sub>OUT1</sub> (1.5V)	1.5V ≤ V <sub>IN</sub> -V <sub>OUT</sub> ≤ 10V I <sub>OUT</sub> =10mA	-	0.3	6	mV	①
		O.T. (*1)	-	0.6	6		
	ΔV <sub>OUT1</sub> (1.8V)	1.5V ≤ V <sub>IN</sub> -V <sub>OUT</sub> ≤ 10V I <sub>OUT</sub> =10mA	-	0.3	6	mV	①
		O.T. (*1)	-	0.6	6		
	ΔV <sub>OUT1</sub> (2.5V)	1.5V ≤ V <sub>IN</sub> -V <sub>OUT</sub> ≤ 10V I <sub>OUT</sub> =10mA	-	0.3	6	mV	①
	O.T. (*1)	-	0.6	6			
ΔV <sub>OUT1</sub> (3.3V)	1.5V ≤ V <sub>IN</sub> -V <sub>OUT</sub> ≤ 10V I <sub>OUT</sub> =10mA	-	0.5	10	mV	①	
	O.T. (*1)	-	1	10			
ΔV <sub>OUT1</sub> (5.0V)	1.5V ≤ V <sub>IN</sub> -V <sub>OUT</sub> ≤ 10V I <sub>OUT</sub> =10mA	-	0.5	10	mV	①	
	O.T. (*1)	-	1	10			
Load Regulation	ΔV <sub>OUT2</sub> (1.5V)	V <sub>IN</sub> -V <sub>OUT</sub> =2.0V 10mA ≤ I <sub>OUT</sub> ≤ 1.5A	-	3	12	mV	①
		O.T. (*1)	-	6	20		
	ΔV <sub>OUT2</sub> (1.8V)	V <sub>IN</sub> -V <sub>OUT</sub> =2.0V 10mA ≤ I <sub>OUT</sub> ≤ 1.5A	-	3	12	mV	①
		O.T. (*1)	-	6	20		
	ΔV <sub>OUT2</sub> (2.5V)	V <sub>IN</sub> -V <sub>OUT</sub> =2.0V 10mA ≤ I <sub>OUT</sub> ≤ 1.5A	-	3	12	mV	①
	O.T. (*1)	-	6	20			
ΔV <sub>OUT2</sub> (3.3V)	V <sub>IN</sub> -V <sub>OUT</sub> =2.0V 10mA ≤ I <sub>OUT</sub> ≤ 1.5A	-	3	15	mV	①	
	O.T. (*1)	-	7	20			
ΔV <sub>OUT2</sub> (5.0V)	V <sub>IN</sub> -V <sub>OUT</sub> =2.0V 10mA ≤ I <sub>OUT</sub> ≤ 1.5A	-	5	20	mV	①	
	O.T. (*1)	-	10	35			
Dropout Voltage	V <sub>dif</sub>	ΔV <sub>OUT</sub> =1%, I <sub>OUT</sub> =1.5A	-	1.3	1.5	V	①
Current Limit	I <sub>LIM</sub>	V <sub>IN</sub> -V <sub>OUT</sub> =2.0V	1.5	2.3	-	A	①
Supply Current	I <sub>DD</sub>	V <sub>IN</sub> =V <sub>OUT</sub> +1.3V	O.T. (*1)	5	10	mA	②
Temperature Stability I <sub>OUT</sub> =10mA	T <sub>s</sub> O.T. (*1)	V <sub>IN</sub> -V <sub>OUT</sub> =1.5V I <sub>OUT</sub> =10mA	O.T. (*1)	0.5	-	%	-

Note:

\*1: O.T. denotes the specifications which apply over the range of operating junction temperature (0°C ≤ T<sub>j</sub> ≤ 125°C).

Please be sure that the power consumption does not exceed the power dissipation rating, 1300mW. If the power consumption exceeds the power dissipation rating and the operating junction temperature rises more than the rating, 125°C, the IC enters thermal shutdown state.

## ■ ELECTRICAL CHARACTERISTICS (Continued)

XB1086K12BJ

 $T_j = 25^\circ\text{C}$  unless otherwise specified

PARAMETER	SYMBOL	CONDITIONS	MIN.	TYP.	MAX.	UNIT	CIRCUIT	
Reference Voltage	$V_{REF}$	$V_{IN}-V_{OUT}=2.0V$ $I_{OUT}=10mA$	1.238	1.250	1.262	V	①	
		O.T. (*1)	1.225	-	1.270			
Line Regulation	$\Delta V_{OUT1}$	$1.5V \leq V_{IN}-V_{OUT} \leq 10V$ $I_{OUT}=10mA$	-	0.015	0.2	%	①	
		O.T. (*1)		0.035	0.2			
Load Regulation	$\Delta V_{OUT2}$	$V_{IN}-V_{OUT}=2.0V$ $10mA \leq I_{OUT} \leq 1.5A$	-	0.1	0.3	%	①	
		O.T. (*1)		0.2	0.4			
Dropout Voltage	$V_{dif}$	$\Delta V_{OUT}=1\%$ , $I_{OUT}=1.5A$	-	1.3	1.5	V	①	
Current Limit	$I_{LIM}$	$V_{IN}-V_{OUT}=2.0V$	1.5	2.3	-	A	①	
Temperature Stability	$T_s$	$V_{IN}-V_{OUT}=1.5V$ $I_{OUT}=10mA$	O.T. (*1)	-	0.5	-	%	-
Minimum Output Current	$I_{OUTmin}$	$1.4V \leq V_{IN}-V_{OUT} \leq 10V$	O.T. (*1)	-	2	5	mA	①
Adjust Voltage Pin Current	$I_{ADJ}$	$V_{IN}=V_{OUT}+1.5V$ $I_{OUT}=10mA$	O.T. (*1)	-	60	120	$\mu A$	①

Note:

 \*1: O.T. denotes the specifications which apply over the range of operating junction temperature ( $0^\circ\text{C} \leq T_j \leq 125^\circ\text{C}$ ).

 Please be sure that the power consumption does not exceed the power dissipation rating, 1300mW. If the power consumption exceeds the power dissipation rating and the operating junction temperature rises more than the rating,  $125^\circ\text{C}$ , the IC enters thermal shutdown state.

## TEST CIRCUITS

### ●XB1086PxxxJ

Circuit ①

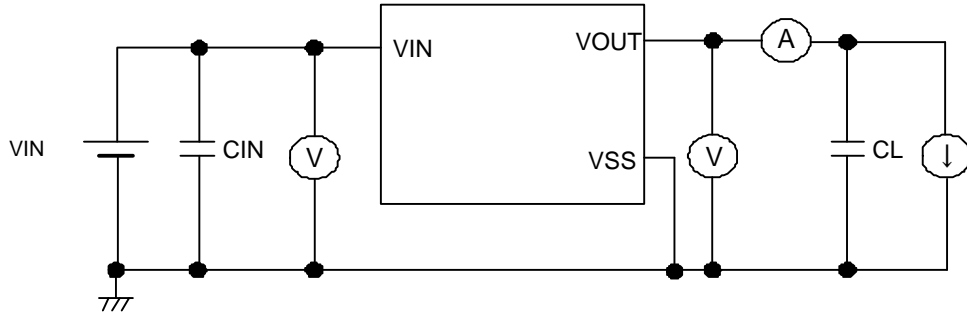

\*  $C_{IN}=10\ \mu\text{F}$  (Tantalum),  $C_L=22\ \mu\text{F}$  (Tantalum)

Circuit ②

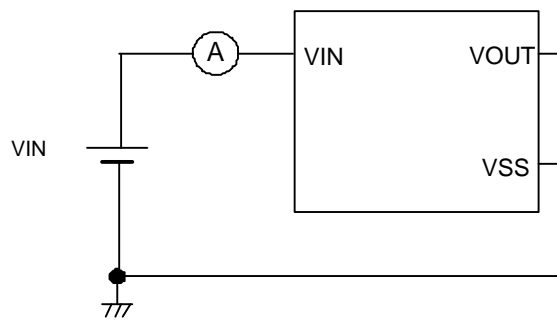

### ●XB1086K12BJ

Circuit ①

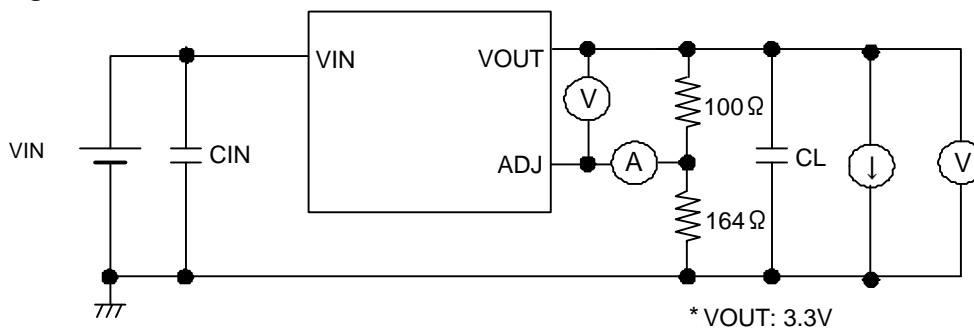

\*  $V_{OUT}: 3.3\text{V}$

\*  $C_{IN}=10\ \mu\text{F}$  (Tantalum),  $C_L=22\ \mu\text{F}$  (Tantalum)

## ■ TYPICAL PERFORMANCE CHARACTERISTICS

(1) Output Voltage vs. Output Current

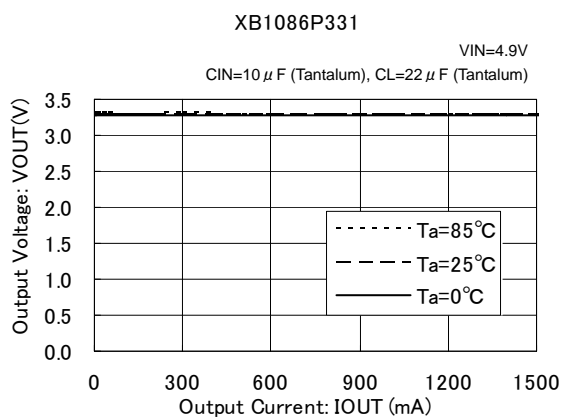

(2) Output Voltage vs. Input Voltage

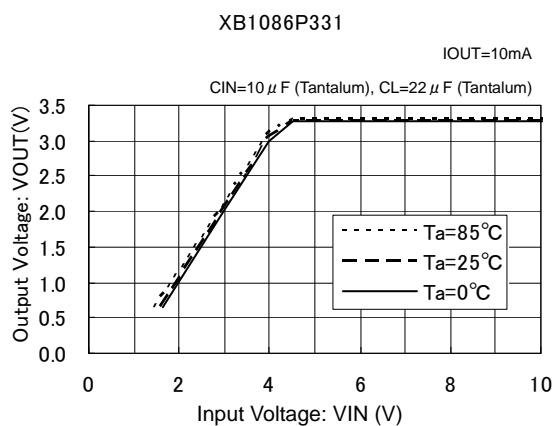

(3) Dropout Voltage vs. Output Current

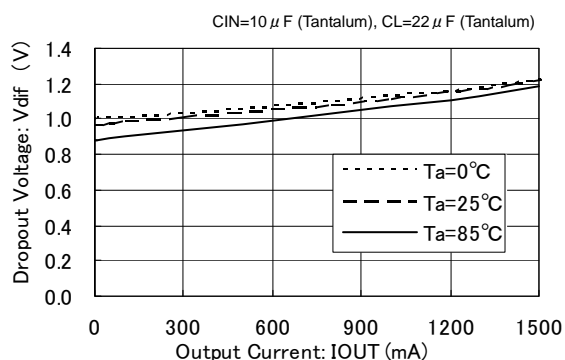

(4) Supply Current vs. Input Voltage

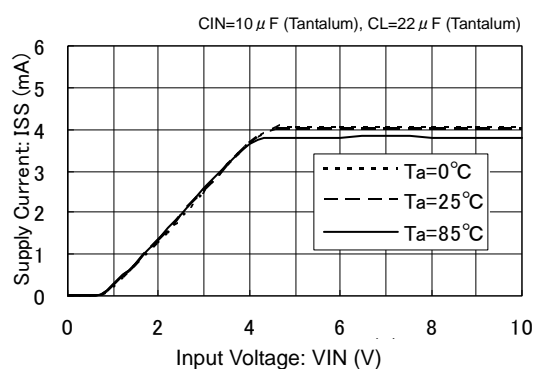

(5) Reference Voltage vs. Ambient Temperature

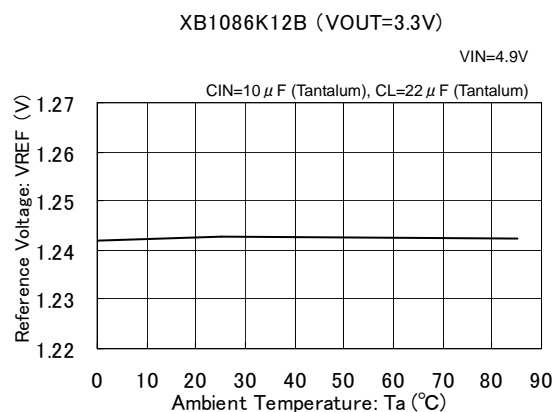

(6) Adjust Pin Current vs. Ambient Temperature

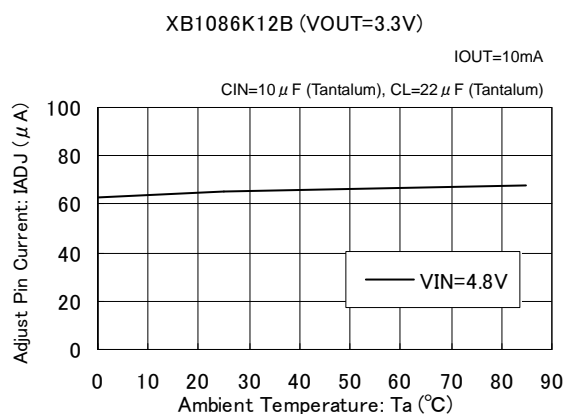

## TYPICAL PERFORMANCE CHARACTERISTICS (Continued)

### (7) Load Transient Response

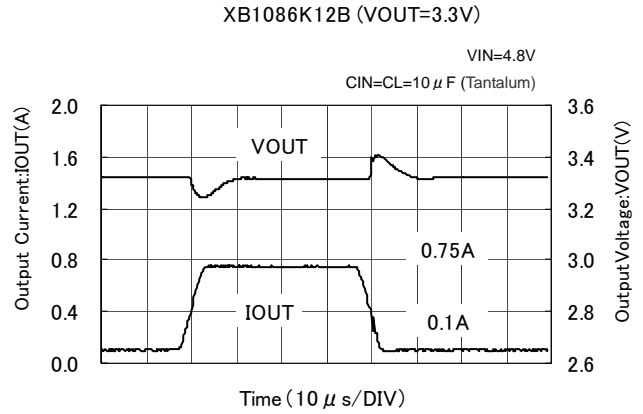
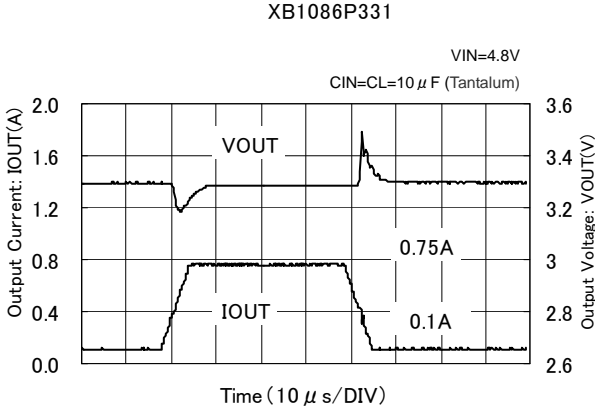

### (8) Input Transient Response

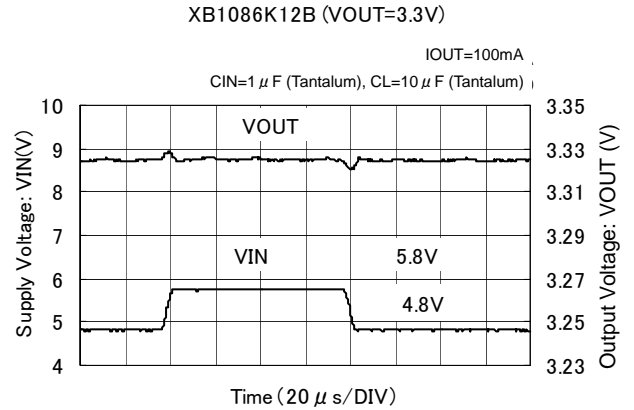
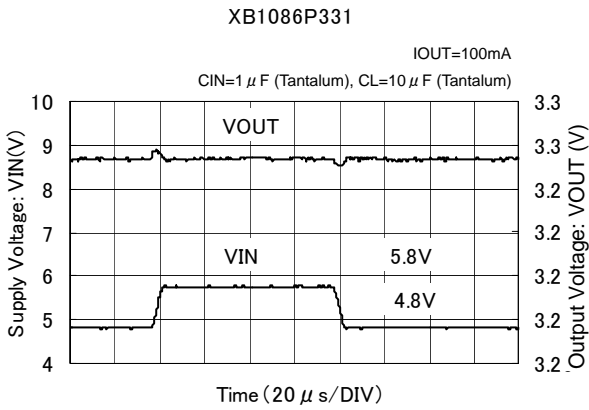

### (9) Ripple Rejection Rate

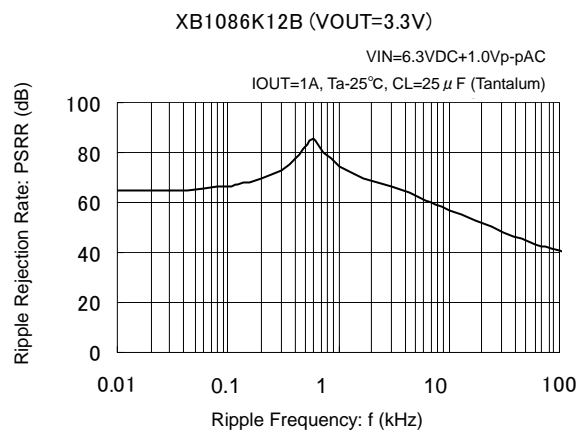
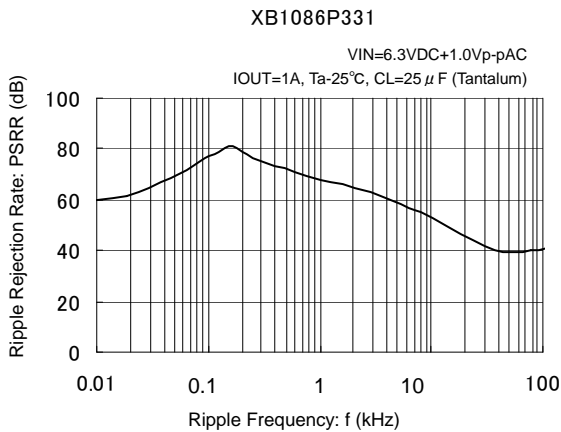

## ■ PACKAGING INFORMATION

● TO-252

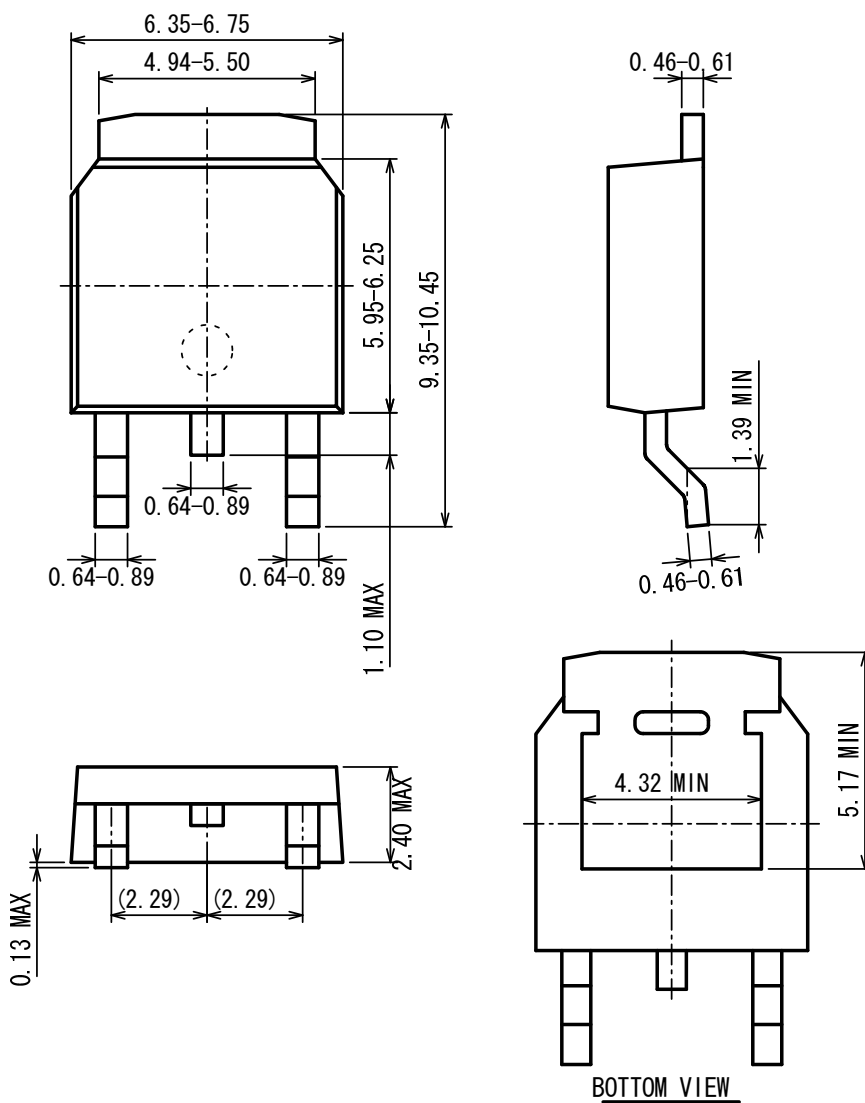

UNIT: mm

## MARKING RULE

●TO-252

(mark header : ①~⑥) \*Mark header does not change with a lot.

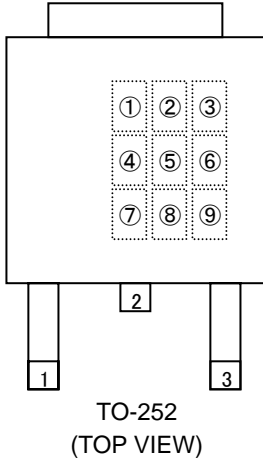

①② represents product series

MARK		PRODUCT SERIES
①	②	
8	6	XB1086****J*

③ represent the type of regulator

MARK		PRODUCT SERIES
P		XB1086P***J*
K		XB1086K***J*

④⑤ represents output voltage

MARK		OUTPUT VOTLAGE PRODUCT SERIES	
④	⑤		
1	5	1.5V	XB1086P151J*
1	8	1.8V	XB1086P181J*
2	5	2.5V	XB1086P251J*
3	3	3.3V	XB1086P331J*
5	0	5.0V	XB1086P501J*
1	2	ADJ	XB1086K12BJ*

⑥ represents output voltage accuracy and output type

MARK	OUTPUT VOLTAGE ACCURACY (OUTPUT TYPE)	PRODUCT SERIES
1	1%	XB1086P**1J*
B	ADJ	XB1086K12BJ*

⑦ represents the last digit of production year  
ex.)

MARK	PRODUCTION YEAR
7	2007
8	2008

⑧ represents production lot number

0 to 9, A to Z repeated.

(G, I, J, O, Q, W excepted. '0' of the first digit does not mark.)

\*No character inversion used.

ex.)

MARK		PRODUCTION LOT NUMBER
⑧	⑨	
Blank	3	03
1	A	1A

1. The products and product specifications contained herein are subject to change without notice to improve performance characteristics. Consult us, or our representatives before use, to confirm that the information in this datasheet is up to date.
2. We assume no responsibility for any infringement of patents, patent rights, or other rights arising from the use of any information and circuitry in this datasheet.
3. Please ensure suitable shipping controls (including fail-safe designs and aging protection) are in force for equipment employing products listed in this datasheet.
4. The products in this datasheet are not developed, designed, or approved for use with such equipment whose failure or malfunction can be reasonably expected to directly endanger the life of, or cause significant injury to, the user.  
(e.g. Atomic energy; aerospace; transport; combustion and associated safety equipment thereof.)
5. Please use the products listed in this datasheet within the specified ranges.  
Should you wish to use the products under conditions exceeding the specifications, please consult us or our representatives.
6. We assume no responsibility for damage or loss due to abnormal use.
7. All rights reserved. No part of this datasheet may be copied or reproduced without the prior permission of TOREX SEMICONDUCTOR LTD.

**TOREX SEMICONDUCTOR LTD.**