

DASH NO.	M CODE	MADE FROM
----------	--------	-----------

GSD

KC-59-280

REVISIONS	
ISSUE	CHANGES
8	CN 37052 B JJS 07/09/96
9	CN 39422 C JPK 03/15/06

KC-59-280SD

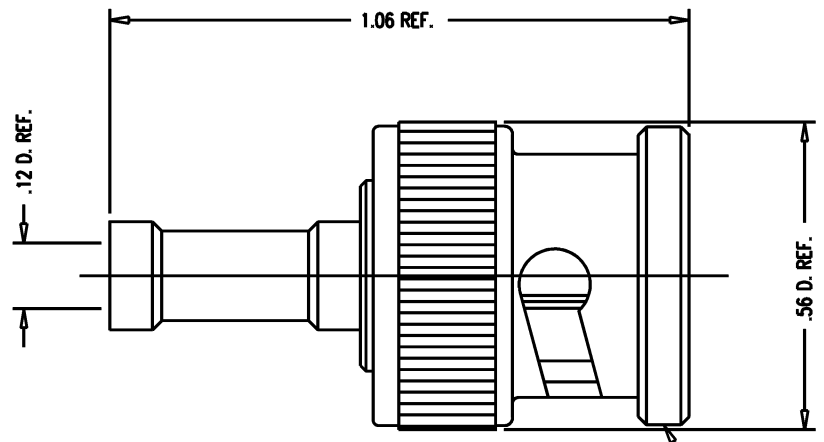

STAMP: KINGS KC-59-280

NOTES:

- FOR USE WITH M17/119-RG174, M17/094-RG179 & M17/113-RG316 CABLE.
- FOR CABLING INSTRUCTIONS SEE CP-402.
- FOR CABLE TRIMMING USE KTJ-100 AND KTD-145.
- FOR CRIMPING USE DIE KTH-2081.
- MATERIALS:
 - INSULATORS-TEFLON, ASTM-D4894
 - GASKET-SILICONE RUBBER, A-A-59588
 - K-GRIP SLEEVE-COM. BRONZE TUBE, ASTM-B135
 - OUTER CONTACT
 - CENTER CONTACT } BER. COP., ASTM-B196
 - SPRING WASHER
 - ALL OTHER METAL PARTS-BRASS, ASTM-B16
- FINISHES:
 - ALL METAL PARTS-SILVER PLATE PER ASTM-B700
- ELECTRIAL CHARACTERISTICS:
 - NOMINAL IMPEDANCE-50 OHMS
 - WORKING VOLTAGE-500 VRMS
 - FREQUENCY RANGE-DC TO 4 GHZ

SCALE	4 : 1		
APPROX SURFACE AREA	N/A		
USED ON			
REF:			
PLUG, BNC			
DRAWN	JCA	DATE	03/05/92
DESIGN	MJB	DATE	03/05/92
APPR.		DATE	



GSD

KC-59-280