

40V/1.5A Step-down High Brightness LED Driver

Features

- Simple low parts count
- Wide input voltage range: 8V to 40V
- Up to 1.5A output current
- Output current limit protection
- Over temperature protection
- Single pin on/off and brightness control using DC Voltage or PWM
- Typical 5% output current accuracy
- Inherent open-circuit LED protection
- High efficiency (up to 97%)
- Adjustable LED constant current

Applications

- MR16 LEDs
- Automotive lighting
- Low Voltage industrial lighting
- illuminated signs

Description

The WS3215 is a continuous conduction mode inductive step-down converter designed for driving single or multiple series LED efficiently from a voltage source higher than the total LED chain voltage. The device operates from an input supply between 8V and 30V and provides an external adjustable output current of up to 1.5A. Depending upon supply voltage and external components, the WS3215 can provide more than 10 watts of output power. The WS3215 includes the power switch and a high-side output current sensing circuit which uses an external resistor to set the nominal average output current, and a dedicated DIM input accepts either a DC voltage or a wide range of pulsed dimming. Applying a voltage of 0.3V or lower to the DIM pin turns the output off and switches the device into a low current standby state. WS3215 using SOT89-5 package .

Typical Application Circuit

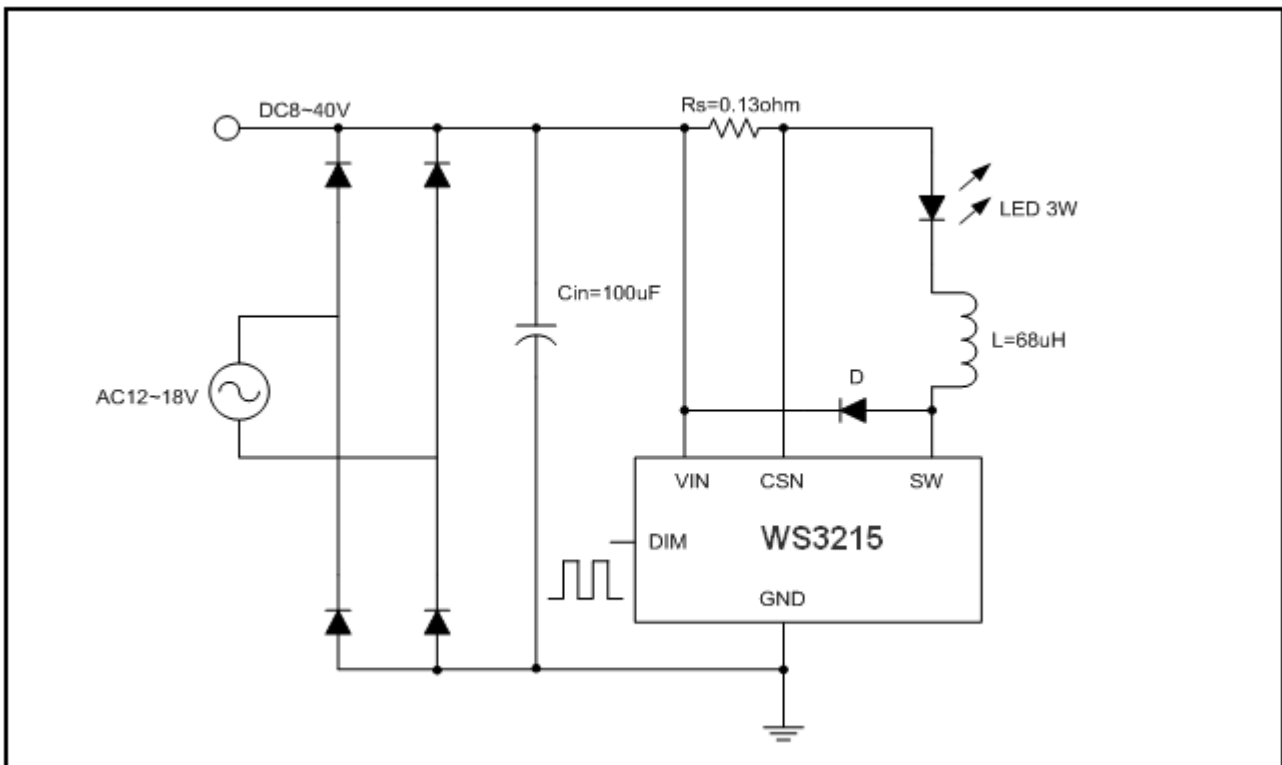

Pin Definition and Device Marking

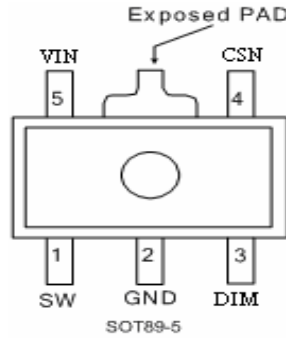

Pin Function Description

Pin Name	Pin No.	Pin Type	Function Description
SW	1	Output	Drain terminal of internal Power MOSFET.
GND	2	Power	Signal and Power GND.
DIM	3	Floating	Used for enabling Switch and Dimming with either a DC voltage or PWM input signal .
CSN	4	Current Monitoring	Used for high-side output current sensing with an external sensing resistance between CSN and VIN.
VIN	5	Frequency Setting	Power supply input. Bypass with capacitor as close to the device as possible .
Exposed PAD	6	Floating	Connected to GND for thermal considerations and pasted on PCB for reducing thermal resistance.

Block Diagram

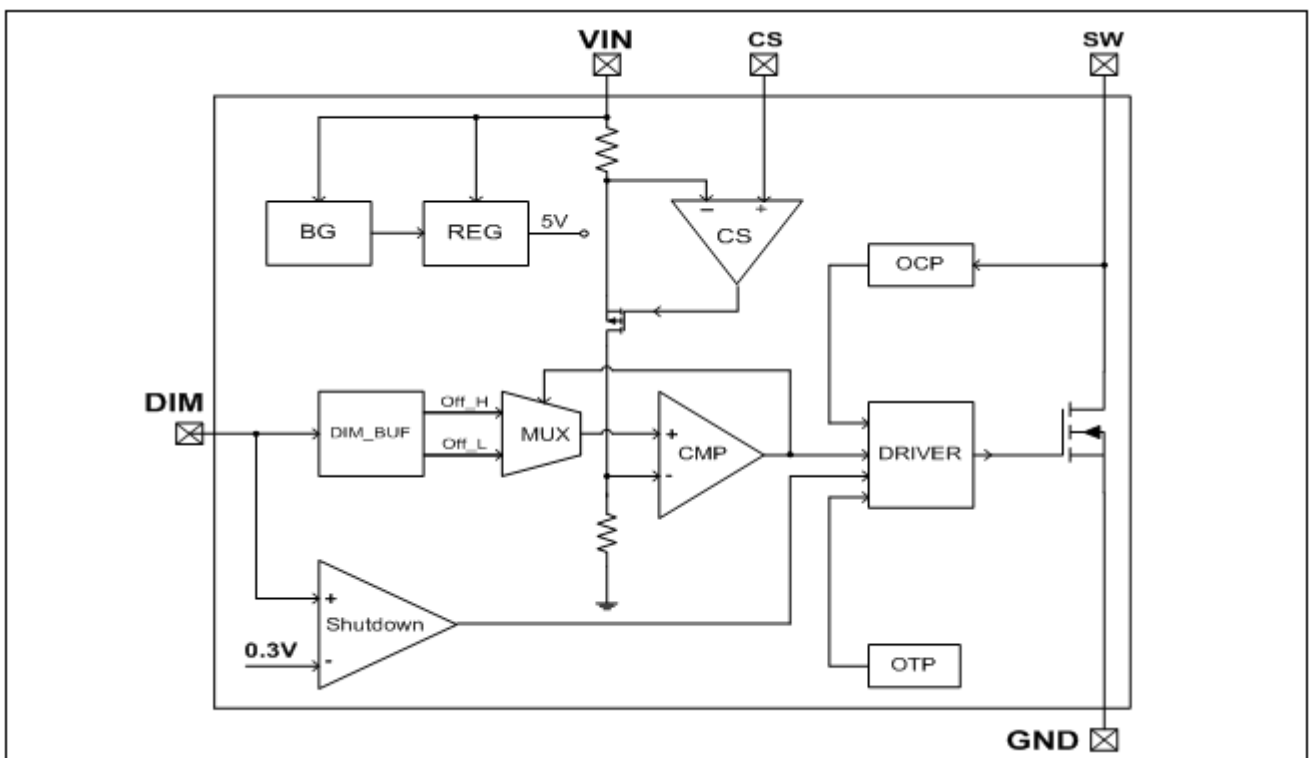

Ordering Information

Package	IC Marking Information	Purchasing Device Name
SOT89-5 Pb-free	WS3215 TP	WS3215

Recommended Operating Condition

Symbol	Parameter	Value	Unit
V _{IN}	Input voltage	8~40	V
T _A	Operating temperature	-20~85	°C

Absolute Maximum Ratings (Note 1)

Symbol	Parameter	Value	Unit
V _{IN}	DC Supply Voltage	-0.3~50	V
SW	Drain voltage of internal Power MOSFET	-0.3~50	V
CSN	Output current sensing voltage(relative toV _{IN})	0.3~-6.0	V
DIM	Switch enable and Dimming Voltage	-0.3~6.0	V
I _{SW}	Maximum Output Current	1.8	A
P _{DMAX}	Power Dissipation(Note 2)	1.5	W
P _{TR}	Thermal Resistance,SOT89-5(θJA)	45	°C/W
T _J	Junction Operating Temperature	-40 to 150	°C
T _{STG}	Storage Temperature	-55 to 150	°C

Note1: Absolute maximum ratings are limits beyond which damage to the device may occur. Operating Ratings are conditions for which the device is intended to be functional, but device parameter specifications may not be guaranteed. For guaranteed specifications and test conditions, see the Electrical Characteristics.

Note 2: Higher temperature leads to the necessary decreasing of maximum power dissipation. It also decided by both T_{JMAX}, θ_{JA},and ambient temperature T_A. The maximum accepted power is formulated as P_{DMAX} = (T_{JMAX} -T_A)/ θ_{JA} or the value among the lower ones in the absolute maximum rating.

ESD Information

Symbol	Parameter	Value	Unit
V _{ESD-HBM}	Human body model on all pins(Discharge with a 100pF capacitor through a 1.5kΩ resistance.)	4	KV
V _{ESD-MM}	Machine model on all pins	400	V

Electrical Characteristics ($V_{IN}=12V, T=25^{\circ}C$. (unless otherwise specified)) (Note3, 4)

Symbol	Parameter	Test Conditions	Min	Typ	Max	Unit
V_{IN}	Supply Voltage	-	8		40	V
V_{UVLO}	V_{IN} UVLO Threshold	V_{IN} Dscreasing		6.8		V
$V_{UVLO,HYS}$	V_{IN} UVLO Hysteresis	V_{IN} Increasing		500		mV
F_{SW}	Maximal Oscillating Frequency				1	MHz
Sensing Current						
V_{CSN}	Average Sensing Voltage	$V_{IN}-V_{CSN}$	95	100	105	mV
$V_{CSN,hys}$	Sensing Voltage Hysteresis			± 10		%
I_{CSN}	Input Current from CSN	$V_{IN}-V_{CSN}=50mV$		8		μA
Turn-off Current						
I_{OFF}	Turn-off Current	$V_{DIM}<0.3V$		50		μA
DIM Input						
V_{DIM}	Internal Supply Voltage	DIM floating		5		V
$V_{DIM,H}$	High Level for DIM Input Voltage		2.5			V
$V_{DIM,L}$	Low Level for DIM Input Voltage				0.3	V
$V_{DIM,DC}$	Dimming Rang with a DC Voltage		0.5		2.5	V
f_{DIM}	Maximal PWM Dimming Frequency	$f_{OSC}=500kHz$			50	kHz
$D_{PWM,LF}$	Duty Range of PWM Dimming at low frequency	$f_{DIM}=100Hz$	0.02%		1	
	PWM Dimming Ratio at low frequency			5000:1		
$D_{PWM,HF}$	Duty Range of PWM Dimming at high frequency	$f_{DIM}=20KHz$	4%		1	
	PWM Dimming Ratio at high frequency			25:1		
R_{DIM}	Pull-up Resistance between DIM and internal Supply Voltage			1.2		$M\Omega$
$I_{DIM,L}$	Leakage Current	$V_{DIM}=0$		4.2		μA
Switching						
R_{SW}	SW Turn-on Resistance	$V_{IN}=24V$		0.5		Ω
		$V_{IN}=12V$		0.5		
$I_{SW,mean}$	SW Continuous Current				1.5	A
I_{LEAK}	SW Leakage Current			0.5	5	μA
Thermal Protection						
T_{SD}	OTP Threshold			160		$^{\circ}C$
$T_{SD,hys}$	OTP Hysteresis			20		$^{\circ}C$

Note 3: Typical numbers are measured at 25°C as standard parameter.

Note 4: In this datasheet, design methods, measurement and statistical analysis guarantee the typical value while measurement guarantees the range between the minimum and maximum.

Typical Operating Characteristics

Efficiency

L=47uH, Rs=0.27ohm

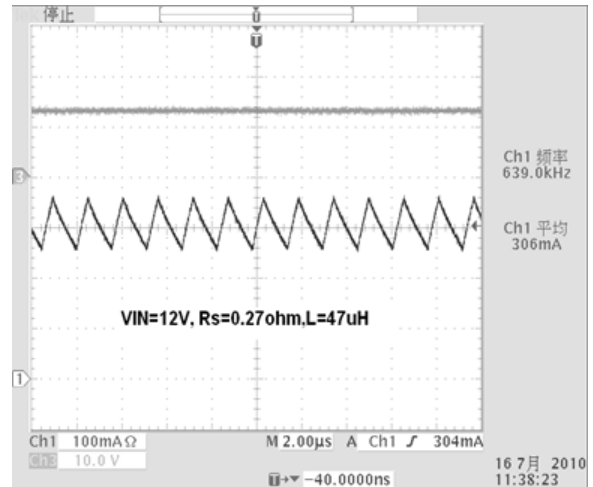
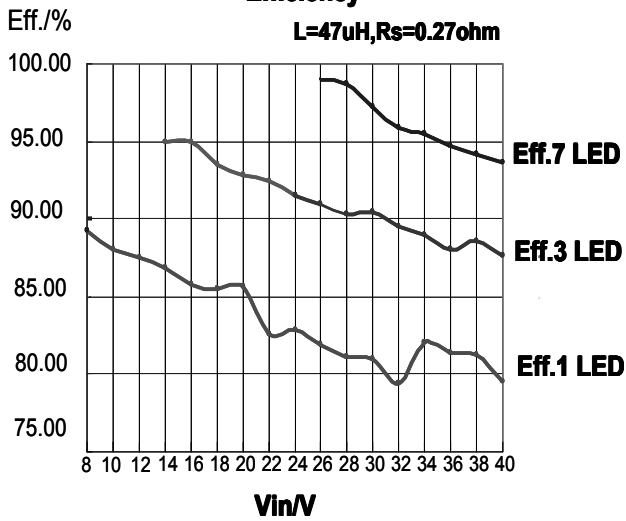

Vdim vs temperature

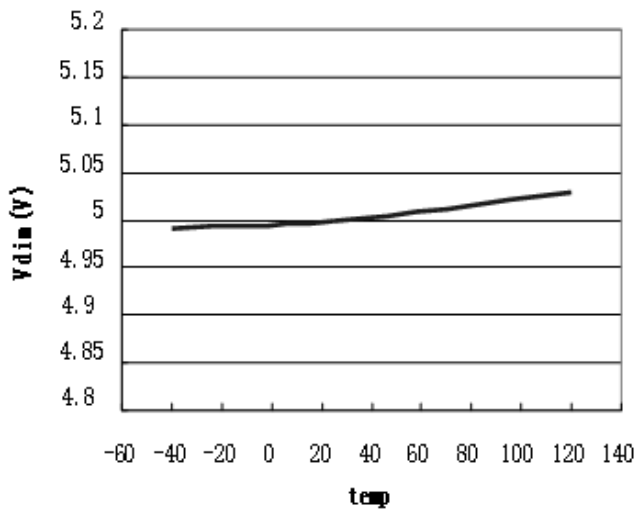

Vdim vs VIN

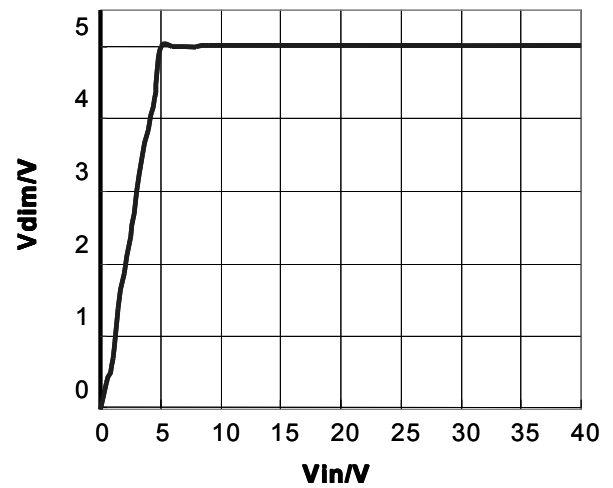

Ioff vs Vin

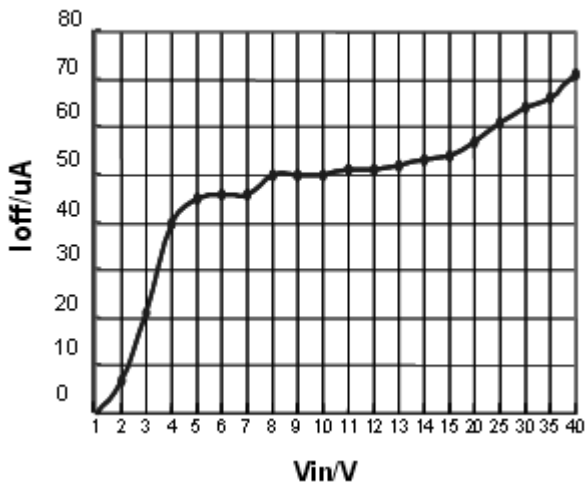

Rsw vs temperature, Vin=24V

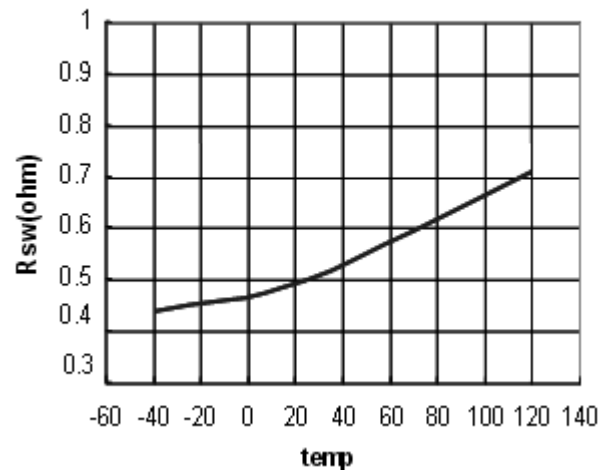

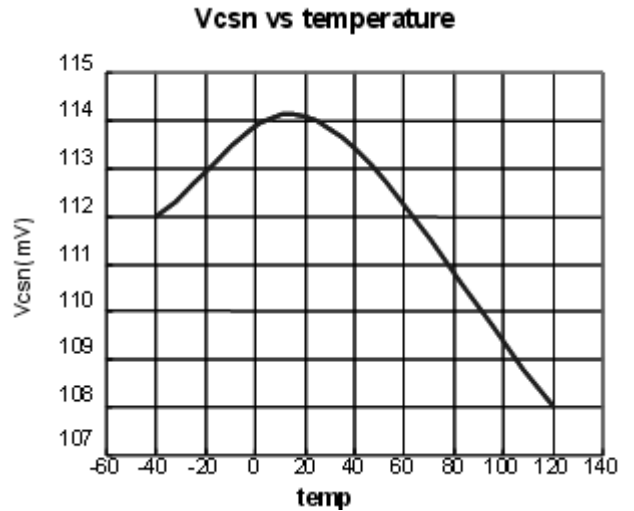
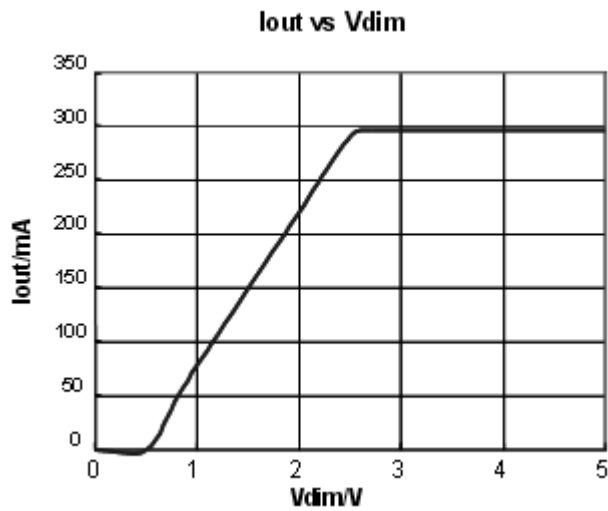
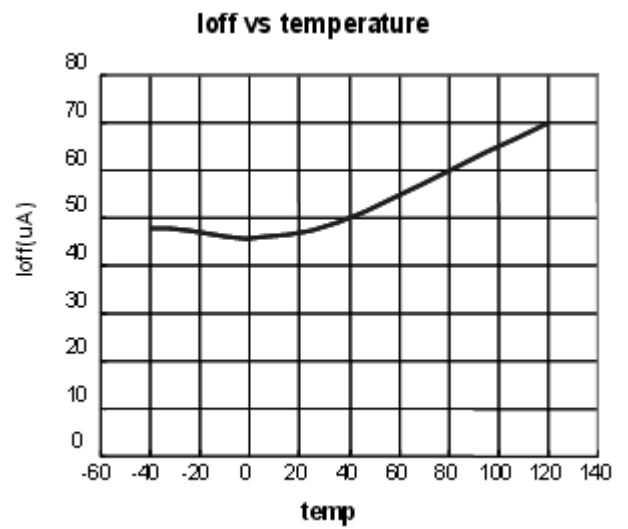
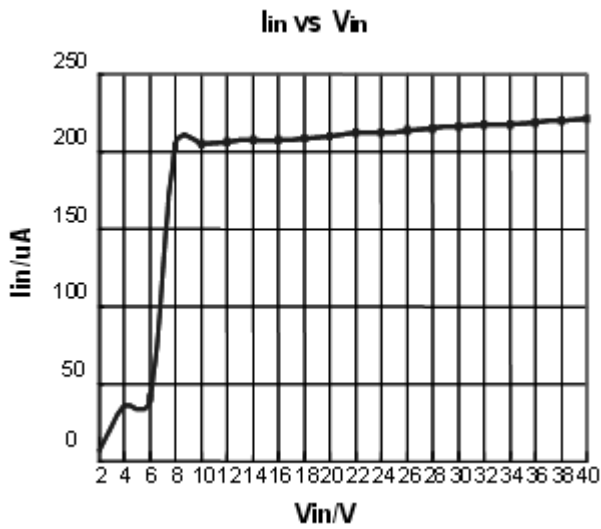

Output Current Deviation $L=47\mu H$ $R_{cs}=0.13\Omega$

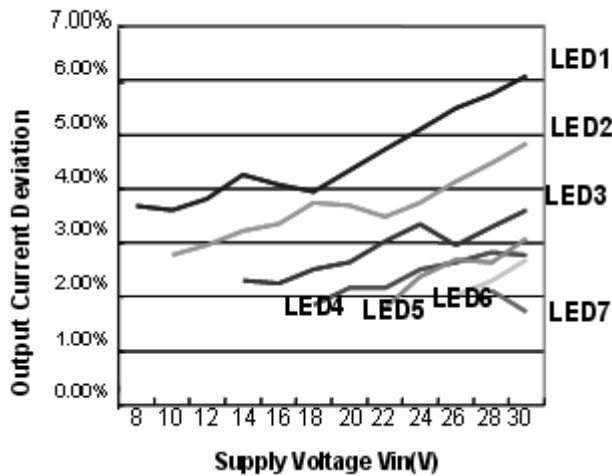

Output Current $L=47\mu H$ $R_{cs}=0.13\Omega$

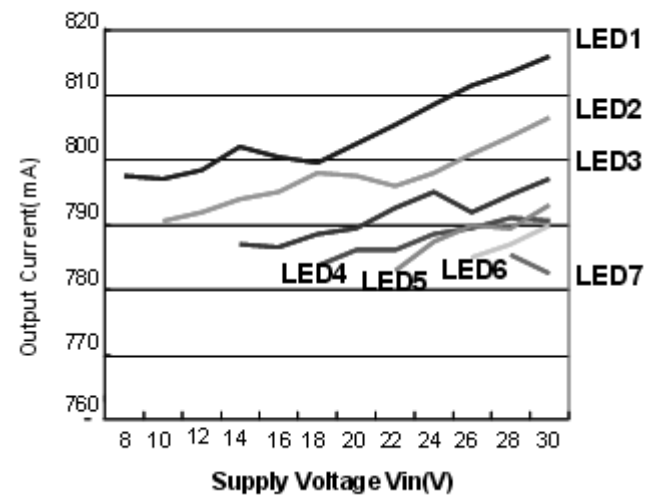

Duty Cycle L=47uH Rcs=0.13ohm

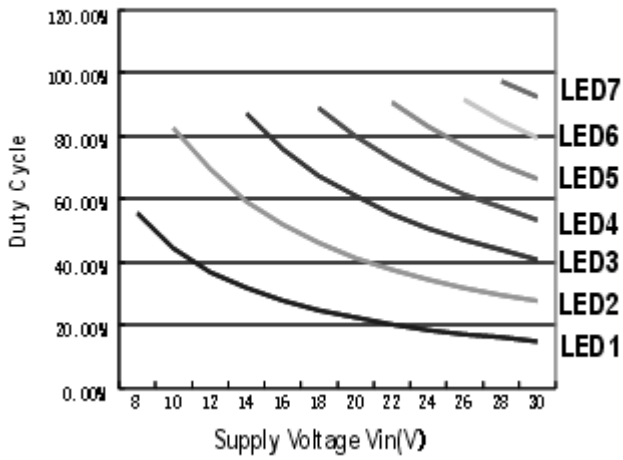

Switch Frequency L=47uH Rcs=0.13ohm(tttt25)

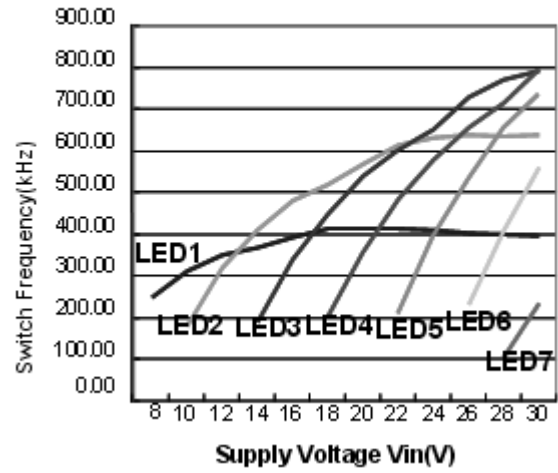

Iout vs Duty Cycle

— 100Hz — 20KHz — 50KHz

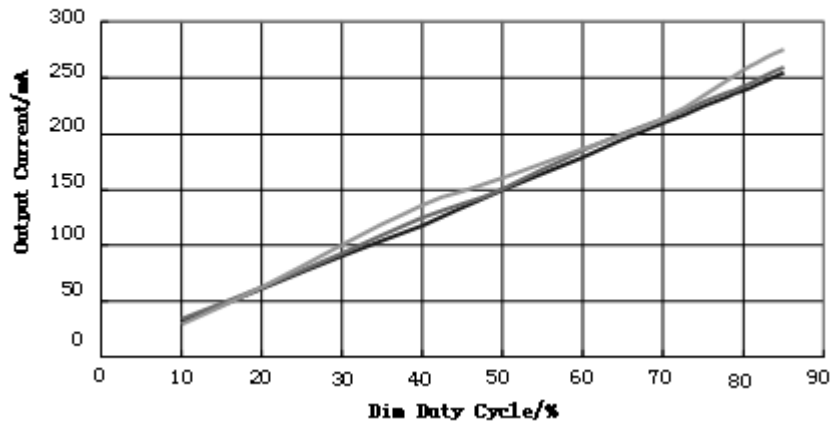

Operation Description

Applying WS3215 with inductor (L) and current sensing resistance (RS) forms a self-oscillating step-down continuous current mode inductive LED controller. When Vin increases at the beginning, LED output current are zero initially through inductor, sensing resistance. Meanwhile, the CS comparator turns high, the voltage of SW is low and the internal power MOSFET is conductible. Through the external components and internal power MOSFET to GND, output current gets greater with a constant rate determined by the voltage difference between inductor's two terminals, then generate a sensing voltage on the RS. If (Vin-Vcsn)>110mV, CS comparator turns low and internal power MOSFET turn off, the state can not change until (Vin-Vcsn)<90mV. As a result, the Average LED output current can be caculated by the following equation:

$$I_{out} = \frac{0.09 + 0.11}{2 \times R_s} = 0.1 / R_s$$

High-side current sensing circuit is applied for less external components. With 1% accuracy of sensing

resistance, the LED output current can be controlled within 5% variation. A dedicated DIM input accepts a wide range of a DC voltage or pulsed dimming. Applying a voltage of 2.5V or higher to the DIM pin will turn on the power MOSFET completely, however, 0.3V or lower will turn the output off. Therefore, it is available to receive a PWM dimming frequency range from 100Hz to 20KHz. Otherwise, an external resistance can be used to set the LED output current. Linking with the internal pull-up resistance (typically 1.2 Mohm) , which is connected to the inner regulated 5V, a voltage applied to the DIM can be achieved. By changing the ratio between the outer and inner resistance, the dimming voltage can be different and brightness of LED can be adjustable.

During the turn-off phase, the quiescent current is only 60uA although the inner reference module is still at work.. For the consideration of reliability, over-temperature protection in WS3215 is necessary. It avoids the WS3215 suffering over-temperature damage and guarantees the maximum LED output current after recovery to normal.

SOT89-5 Package Dimension

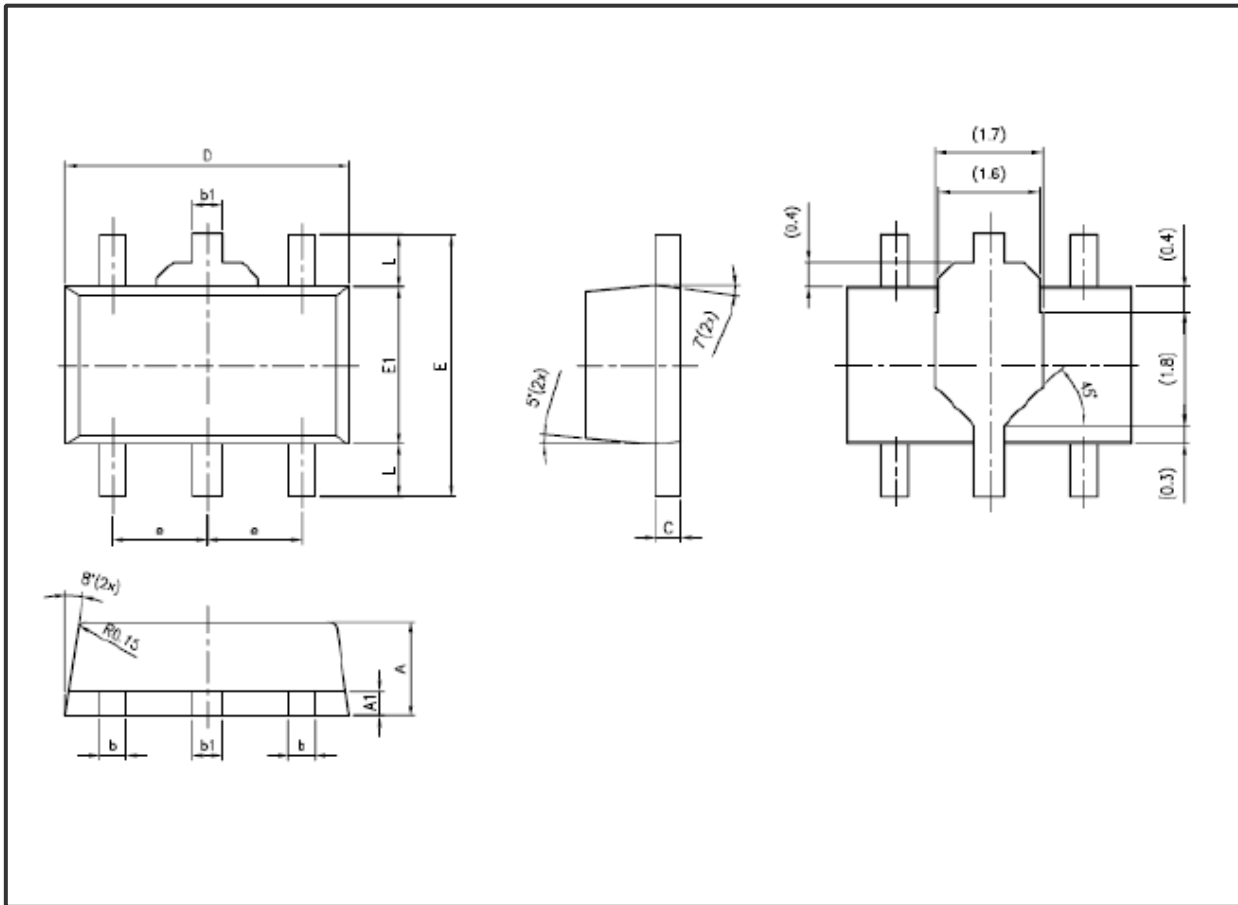

符号	毫米		
	最小	典型	最大
A	1.40	1.50	1.60
A1	0.30	0.40	0.50
b	0.36	0.42	0.48
b1	0.41	0.47	0.53
C	0.38	0.40	0.43
D	4.40	4.50	4.60
E	—	—	4.25
E1	2.40	2.50	2.60
e	1.40	1.50	1.60
L	0.80	—	—