

# Solid Optical Fingerprint Sensor SEF-A1F1

## OUTLINE

An optical sweep-type compact fingerprint sensor. Eliminates the shortcomings of conventional optical fingerprint sensors, which are large and heavy due to use of lenses and prisms. The interdigital scattered light method realizes stable, high-accuracy detection at low-cost with a major reduction in size and weight. Increased resistance to static and shock make this technology ideal for inclusion with a variety of devices.

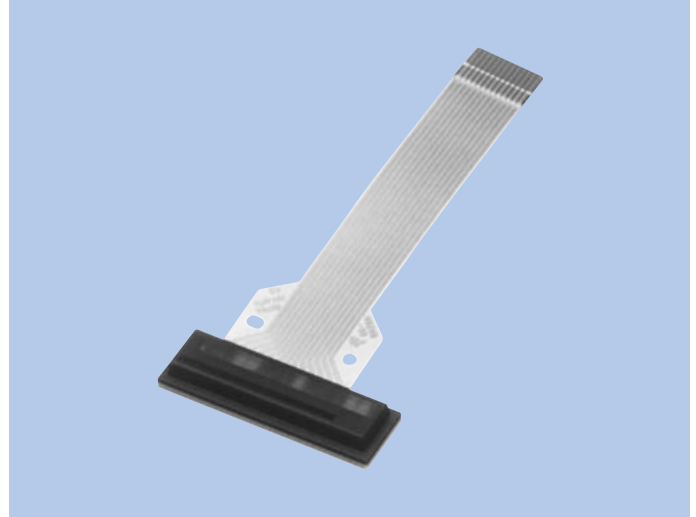

## FEATURES

1. Small size and light weight achieved by molding optical components as one piece.
2. The semiconductor is not exposed, giving excellent durability.
3. Waterproofing improved through use of a flange.
4. The finger scattered light method allows use on wet fingers.
5. The light filter allows use on dry fingers.
6. A signal processing LSI can be provided (supports SPI and parallel I/F).

## USES

1. PC units, portable information devices, network terminals
2. IC card readers
3. Security devices

## SPECIFICATIONS

Item	Specification
Fingerprint detection method	Sweep-type interdigital scattered light method
Structure	Single-unit mold including light-source LEDs
Pixels	600dpi-256 pixels/line
Sweep speed	10cm/sec
Temperature range	Storage: -20 to +80°C, Operation: -5 to +70°C
Electrostatic discharge resistance	20kV or greater
Power source voltage	5.0±0.5V
Consumption current	35mA typ.
Dimensions	18.2 (W) × 4.8 (D) × 2.8 (H) mm (not including flange)

\*Specifications may be changed for the purpose of improvement and upgrading.

## DIMENSIONS

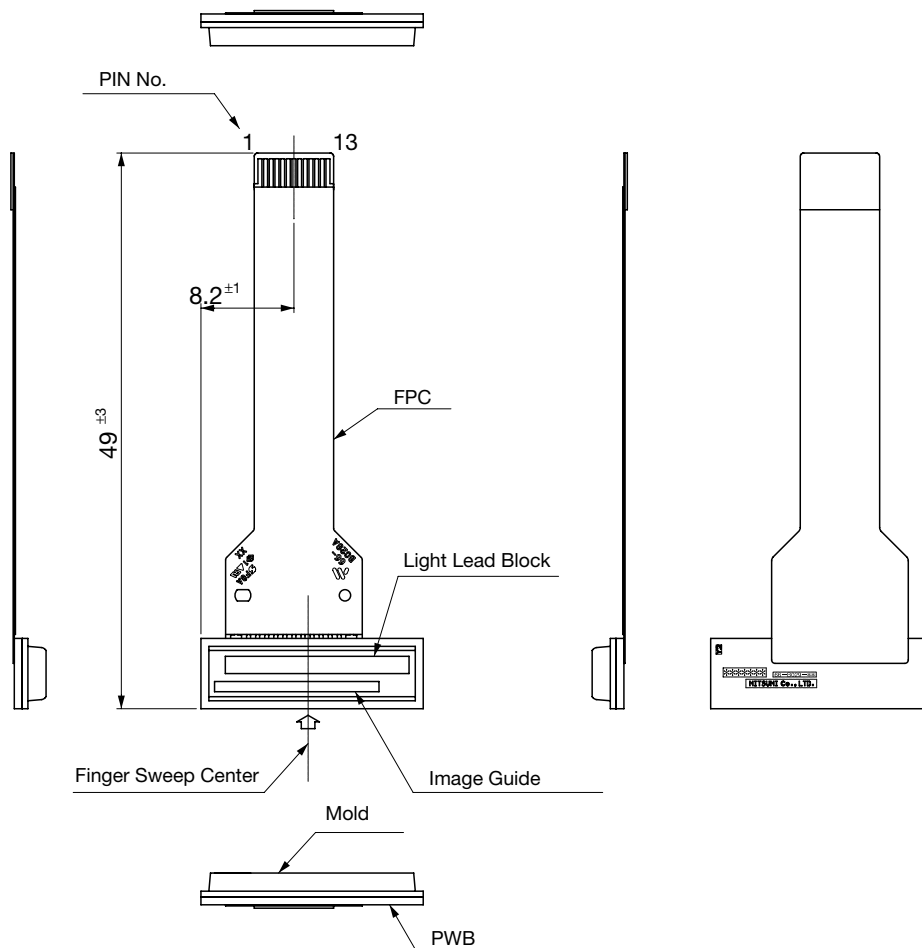

Unit: mm