

WSP6580Q

SwitchPro Family High Fidelity Stereo SPDT Switch with Pop and Click Suppression

<http://www.willsemi.com>

Descriptions

With **SwitchPro** technology, The WSP6580Q is a Dual SPDT analog switch with ultra-low distortion, high OFF-Isolation for special stereo audio applications with negative swing audio signals capacity that features ultra-low Ron of 0.2Ω (typical) at 3.3V VCC.

The WSP6580Q operates a single power supply over a wide range from 3.0V to 4.5V and 1.8V logic compatible with ultra high PSRR. With a special pop-click shunt circuitry at each signal pin that eliminates pops and clicks associated at any application conditions likes switched, enable/disable, power-down and power-up.

With superior THD+N performance and other high performance, the WSP6580Q is an ideal device for Hi-Fi system applications.

The WSP6580Q is available in QFN1826-16L package. All products is Pb-free and Halogen-free.

Features

- Single supply range operating from 2.5V to 4.5V
- -118dB THD+N into 100kΩ load at 2Vrms
- -114dB THD+N into 32Ω load at 2Vrms
- Signal-to-Noise (SNR) Ratio 132dBA
- 100dB PSRR at 10kHz
- 145dB crosstalk & separation
- Pop/Click shunt circuit
- Adjust soft-start with external capacitor

Applications

- Hi-Fi Smartphones and Portable Device
- Hi-Fi SACD/DVD players
- High Quality Home Theaters

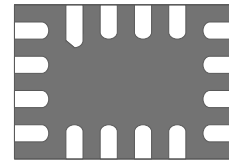

QFN1826-16L (Bottom view)

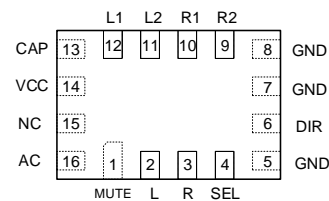

Pin configuration (Top view)

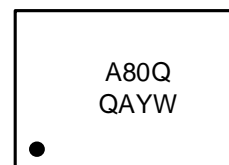

Marking

- A80Q** = Device code
QA = Special code
Y = Year code
W = Month (A~Z)

Order information

Device	Package	Shipping
WSP6580Q-16/TR	QFN1826-16L	3000/Reel&Tape

Pin descriptions

Pin Number	Symbol	Descriptions
2, 3	L, R	left and right channel Common port
10,12	R1, L1	Left and right channel port 1, normally closed
9,11	R2, L2	Left and right channel port 2, normally open
1	MUTE	Enable control, active high
4	SEL	Port selection control pin
16	AC	Shunt circuit enable pin, active high
6	DIR	Audio signal direction control
13	CAP	Soft-start rising time control with external ceramic capacitor
14	VCC	Power supply
5,7,8	GND	Ground
15	NC	Not connection

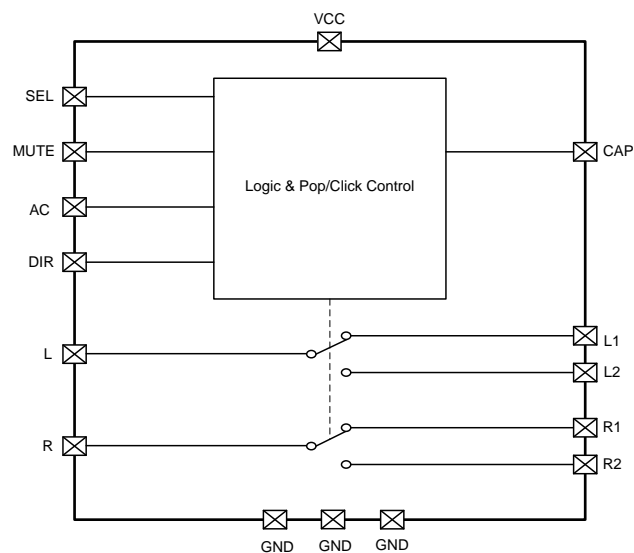
Block Diagram

Figure 1. WSP6580Q Block Diagram
Function Table

AC	DIR	MUTE	SEL	L1,R1	L2,R2	L,R Shunts	L1,R1 Shunts	L2,R2 Shunts
0	X	0	0	ON	OFF	OFF	OFF	OFF
0	X	0	1	OFF	ON	OFF	OFF	OFF
0	X	1	X	OFF	OFF	OFF	OFF	OFF
1	1	0	0	ON	OFF	OFF	OFF	ON
1	1	0	1	OFF	ON	OFF	ON	OFF
1	0	1	X	OFF	OFF	ON	OFF	OFF
1	0	0	0	ON	OFF	OFF	OFF	OFF
1	0	0	1	OFF	ON	OFF	OFF	OFF
1	1	1	X	OFF	OFF	OFF	ON	ON

Note: X=0 or 1, don't care

Typical Applications

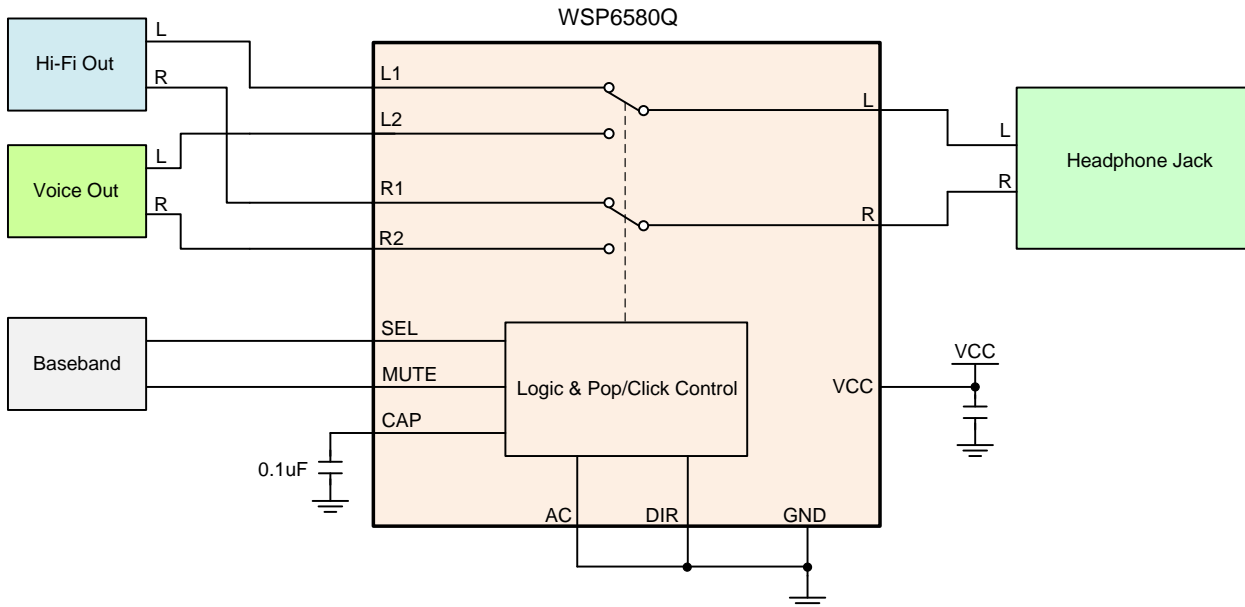

Figure 2. Hi-Fi Phone Application Block Diagram

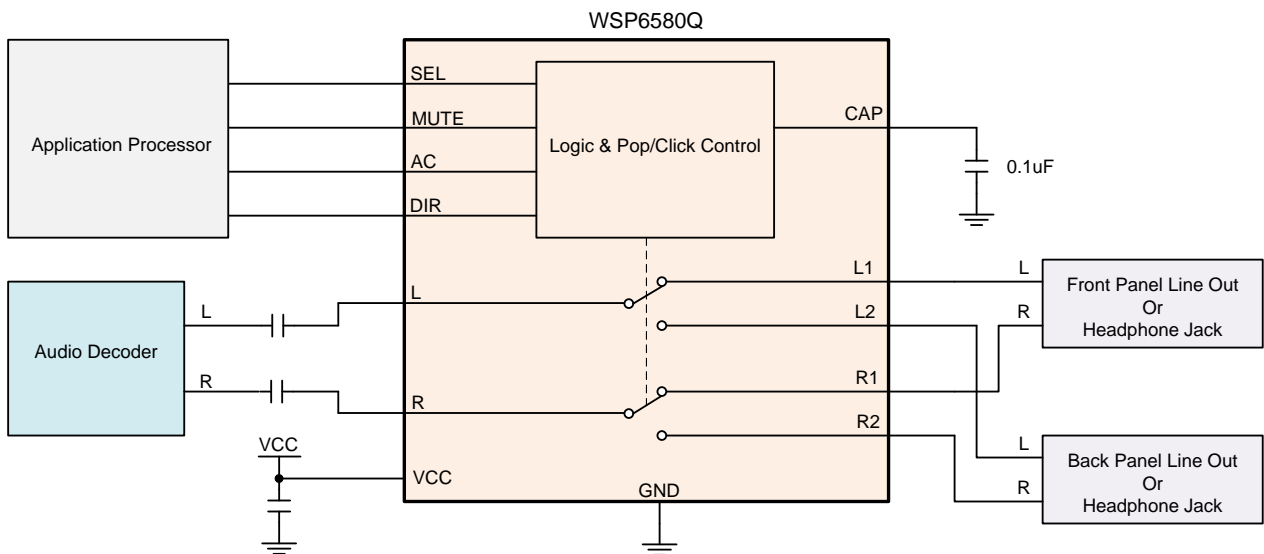

Figure 3. SACD/DVD Players Application Block Diagram

Absolute Maximum Ratings ⁽¹⁾

Parameter	Symbol	Value	Unit
Supply Voltage	V_{CC}	-0.3 ~ 5.5	V
Digital Control Input Voltage	V_{IN}	-0.3 ~ 5.5	V
Analog Input/Output Voltage (L1,L2,R1,R2,L,R)	V_{IS}	-4.0 ~ 4.0	V
Switch Continuous Current (L1,L2,R1,R2,L,R)	I_{IO}	±300	mA
Switch Peak Current (L1,L2,R1,R2,L,R) (pulsed at 1ms, 10% duty cycle, Max)	I_{IO_PK}	±500	mA
Power Dissipation in Still Air	P_D	250	mW
Storage Temperature Range	T_{STG}	-55 ~ 150	°C
Junction Temperature	T_J	150	°C
Lead Temperature (Soldering, 10 seconds)	T_L	260	°C
Thermal Resistance	$R_{\theta JA}$	80	°C/W
ESD protection (HBM)	I/O to VCC, I/O to GND	±6000	V
	I/O to I/O	±4000	V

Recommend operating ratings ⁽²⁾

Parameter	Symbol	Value	Unit
Supply Voltage	V_{CC}	2.5~ 4.5	V
Digital Control Input Voltage	V_{IN}	0.0 ~ V_{CC}	V
Analog Input/Output Voltage (L1,L2,R1,R2,L,R)	V_{IS}	-3.3 ~ V_{CC}	V
Operating Temperature	T_A	-40 ~ 85	°C

Note:

1. "Absolute Maximum Ratings" may cause permanent damage to the device. This is a stress only rating and operation of the device at these or any other conditions beyond those indicated in the operational sections of this specification is not implied.
2. The input and output negative voltage ratings may be exceeded if the input and output diode current ratings are observed.

DC Electronics Characteristics

 (Ta=25°C, VCC=3.6V, V_{AC}=V_{DIR}=0V, V_{IS}=2V_{rms}, R_L=32Ω, f=1kHz, CAP=0.1uF, unless otherwise noted)

Parameter	Symbol	Conditions	Min.	Typ.	Max.	Unit
Analog Switch Characteristics						
Analog Signal Range	V _{IS}	VCC: 3.3 ~ 4.2		2.5		V _{rms}
On-Resistance	R _{ON}	V _{IS} = -3.3V~+3.3V I _{OUT} =100mA		0.2		Ω
R _{ON} Matching Between Channels	Δ R _{ON}	V _{IS} = -3.3V~+3.3V I _{OUT} =100mA		0.0015		Ω
R _{ON} Flatness	R _{FLAT(ON)}	V _{IS} = -3.3V~+3.3V I _{OUT} =100mA		0.0015		Ω
Dynamic Characteristics						
Total Harmonic Distortion	THD+N	f=10Hz to 22KHz V _{IS} =2V _{rms} @R _L =100kΩ		-118		dB
Total Harmonic Distortion	THD+N	f=10Hz to 22KHz V _{IS} =2V _{rms} @R _L =32Ω		-114		dB
Total Harmonic Distortion	THD+N	f=10Hz to 500kHz V _{IS} =1.55V _{rms} @RL=100kΩ		-104		dB
Intermodulation Distortion	IMD	Mode=CCIF 19k+20k Ratio=1 V _{IS} =500mV _{rms} @R _L =100kΩ		-122		dB
Dynamic/Transient Intermodulation Distortion	IMD	Mode=DIM100 V _{IS} =1V _{rms} @ RL=100kΩ		-103		dB
Signal-to-Noise Ratio	SNR	f=10Hz to 22KHz, Inputs grounded R _L =32Ω or 100kΩ		132		dBA
Stereo Channel Imbalance L1 and R1, L2 and R2	IMB	f=10Hz to 22KHz, R _L =100kΩ		±0.003		dB
Off isolation (Muting)	OIRR	f=10Hz to 22KHz, V _L = V _R = 2V _{rms} @R _L =100kΩ MUTE=AC=VCC DIR=0, SEL="X"		145		dB
		f=10Hz to 22KHz, V _{Lx} = V _{Rx} = 2V _{rms} @R _L =100kΩ MUTE=AC=VCC DIR=VCC, SEL="X"		145		dB
		f=10Hz to 22KHz, V _L = V _R = 2V _{rms} @R _L =32Ω		127		dB

		MUTE=VCC AC=DIR=0, SEL="X"				
		f=10Hz to 22KHz, V _{LX} = V _{RX} = 2Vrms @R _L =32Ω MUTE=VCC AC=DIR=0, SEL="X"		127		dB
Crosstalk (Channel-to-Channel)	Xtalk	f=10Hz to 22KHz, V _{IS} = 2Vrms, Source Impedance=0Ω R _L = 100kΩ		145		dB
Power Supply Ripple Rejection	PSRR	f=10kHz, V _{IS} = 0.1Vrms, Inputs grounded		100		dB
-3dB Bandwidth	BW	R _L =50Ω		50		MHz
On-to-Mute Time	T _{TRS-OM}	CAP=0.1uF		50		ns
Mute-to-On Time	T _{TRS-MO}	CAP=0.1uF		160		ms
Turn-Off Time	T _{OFF}	V _{IS} =1.5V, R _L =20KΩ MUTE=0		60		ns
Turn-On Time	T _{ON}	V _{IS} =1.5V, R _L =20KΩ MUTE=0		60		us
Break-Before-Make time	T _{BBM}	V _{IS} =1.5V, R _L =20KΩ MUTE=0		50		us
Lx, Rx Off capacitance	C _{OFF}	f=100kHz, V _{LX} or V _{RX} = V _L or V _R =0V		15		pF
L, R On capacitance	C _{ON}	f=100kHz, V _{LX} or V _{RX} = V _L or V _R =0V		30		pF
Power Supply Characteristics						
Supply quiescent current	I _{CC}	MUTE=0V		190		uA
		MUTE=VCC		55		uA
Digital Input Characteristics						
Digital input logic high level	V _{IH}	VCC=3.6~4.5	1.6			V
		VCC=3.0~3.6	1.5			V
Digital input logic low level	V _{IL}	VCC=3.6~4.5			0.5	V
		VCC=3.0~3.6			0.4	V
Digital Input leakage current	I _{IN}				±2.0	uA
AC, DIR, SEL pull-down resistor	R _{PD}			4		MΩ
MUTE pull-up resistor	R _{PU}			4		MΩ

Note:

- Flatness is defined as the difference between maximum and minimum value of ON-resistance at the specified analog signal voltage points.
- R_{ON} matching between channels is calculated by subtracting the channel with the highest max Ron value from the channel with lowest max ron value.
- Crosstalk is inversely proportional to source impedance.

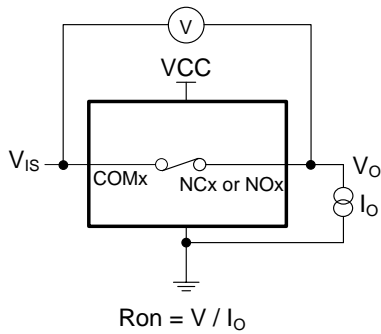
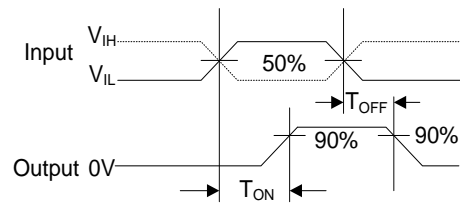
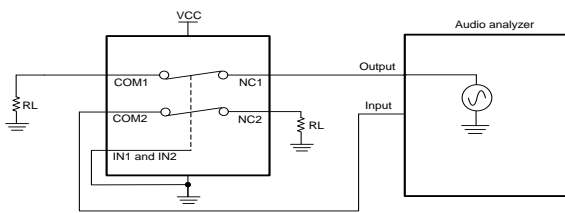
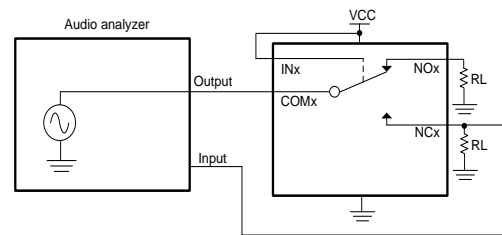
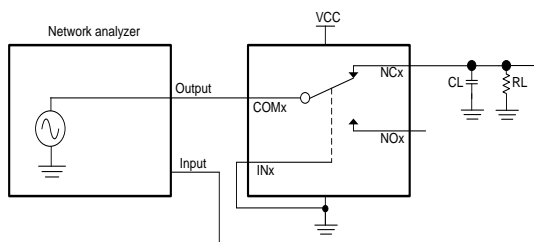
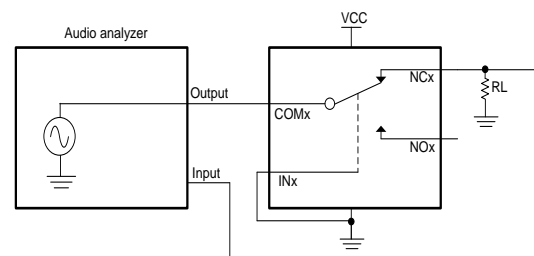
Test Circuits

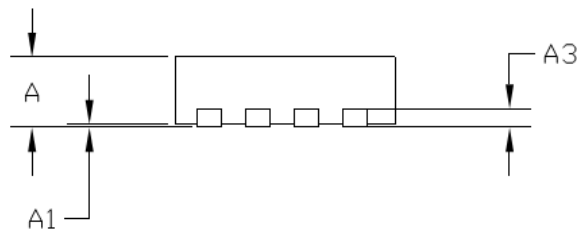
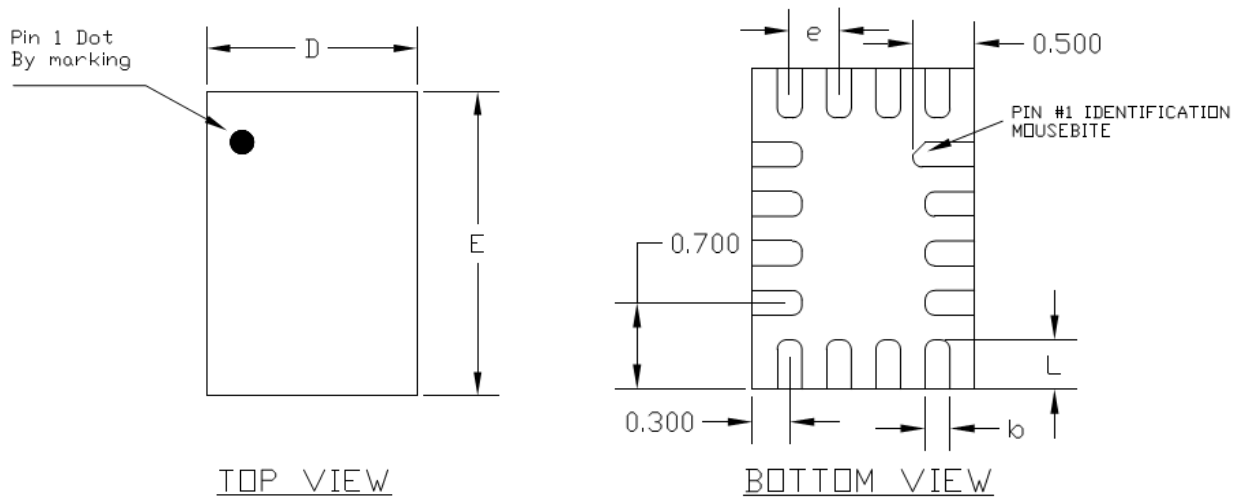
ON-Resistance (R_{ON})

ON/OFF Time Waveforms (T_{ON} / T_{OFF})

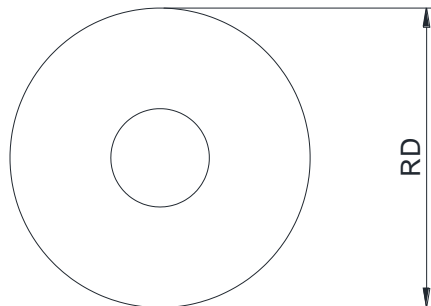
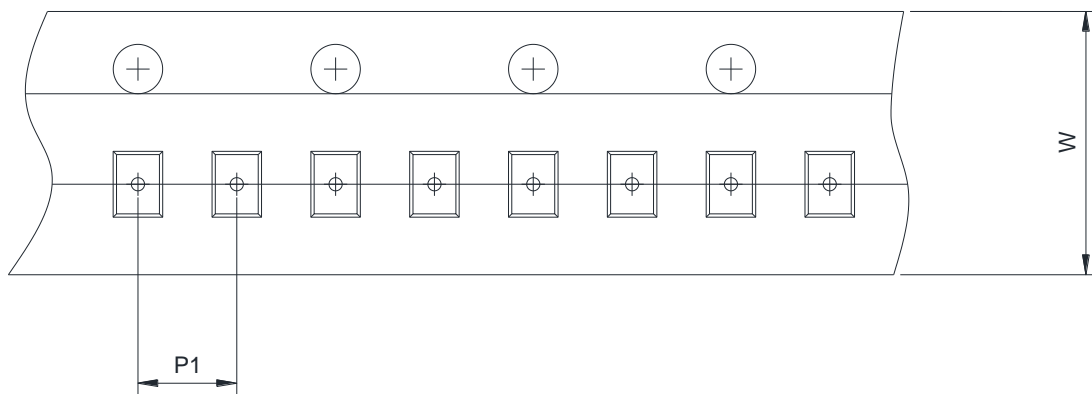
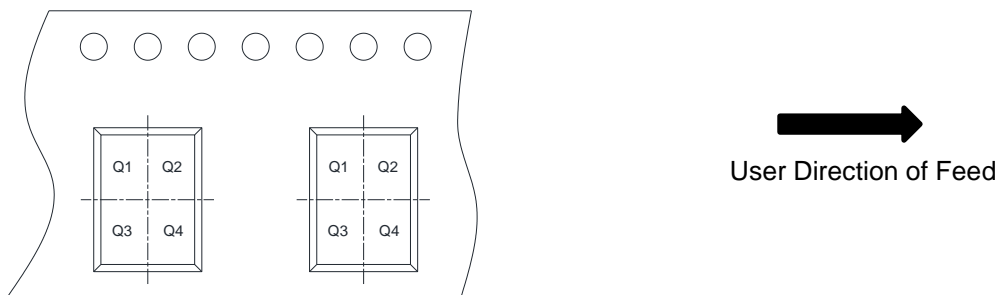
Crosstalk (Xtalk)

Off isolation (OIRR)

Bandwidth (BW)

THD+N

Package outline dimensions
QFN1826-16L

SIDE VIEW

Symbol	Dimension in Millimeters		
	Min.	Typ.	Max.
A	0.50	0.55	0.60
A1	0.00	-	0.05
A3	0.15 Typ.		
D	1.75	1.80	1.85
E	2.55	2.60	2.65
L	0.30	0.40	0.50
b	0.15	0.20	0.25
e	0.40 Typ.		

TAPE AND REEL INFORMATION
Reel Dimensions

Tape Dimensions

Quadrant Assignments For PIN1 Orientation In Tape

RD	Reel Dimension	<input checked="" type="checkbox"/> 7inch	<input type="checkbox"/> 13inch
W	Overall width of the carrier tape	<input checked="" type="checkbox"/> 8mm	<input type="checkbox"/> 12mm <input type="checkbox"/> 16mm
P1	Pitch between successive cavity centers	<input type="checkbox"/> 2mm	<input checked="" type="checkbox"/> 4mm <input type="checkbox"/> 8mm
Pin1	Pin1 Quadrant	<input checked="" type="checkbox"/> Q1	<input type="checkbox"/> Q2 <input type="checkbox"/> Q3 <input type="checkbox"/> Q4