

# Small-Sized, Low Profile Wire-to-Board Connector for Power Supply

## DF61Y Series



### ■ Features

#### 1. Proprietary ViSe Lock design

The lock on the cable side has been strengthened with our proprietary ViSe Lock mechanism\*, preventing cables from being easily disconnected due to tough routing or an excessive load. (\*ViSe lock : Vertical-insertion Swing-extraction) (Fig.1)  
※Patent pending

#### 2. Improved operation through vertical mating

Eliminates wasted board space : Vertical insertion eliminates the board space required for horizontal mating and enhances assembly (Enhanced PCB design freedom) (Fig.2)

#### 3. Small-sized and low profile, with high withstanding voltage and current (H=2mm, 24AWG : 4A Max)

In spite of the small size on a 2.2mm contact pitch, high voltage of 350V is achieved by ensuring creepage distance. Using high conductivity material for the socket contact and lowering contact resistance through optimized contact force, high-current capability is realized.

#### 4. High heat-resistance

Operating temperature limit of 105°C.

#### 5. Halogen-free

Use of chlorine or bromine are within standards values.

\*As defined by IEC61249-2-21  
Br 900ppm max, Cl 900ppm max,  
Br+Cl 1,500ppm max

### Diagram to explain the ViSe Locking Design

Insertion operation is similar to vertical mating. However, the contact is actually inserted at an angle, and ensures high retention force in upper direction. (Cable tensile strength : A minimum of 10N)

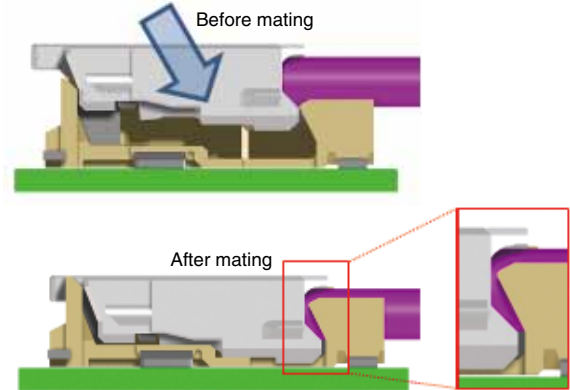

Fig.1

### Improved operation through vertical mating and reduced wasted space

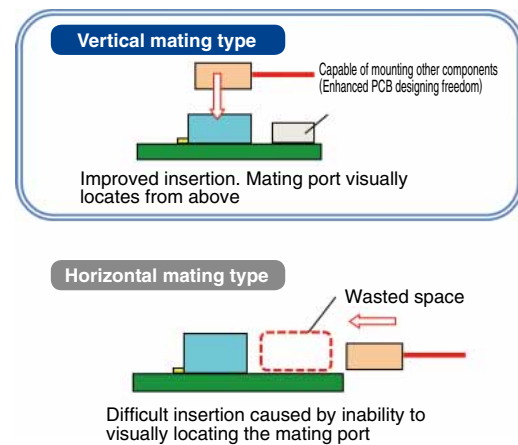
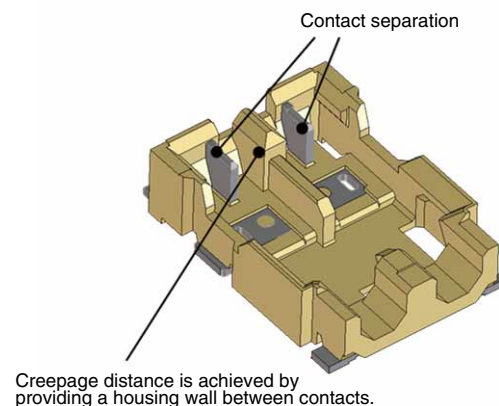

Fig.2

### Long creepage distance



Creepage distance is achieved by providing a housing wall between contacts.

Fig.3

## Product Specifications

Ratings	Current Rating	3.0A (28 AWG) 3.2A (26 AWG) 4.0A (24 AWG)	Operating Temperature Range Operating Humidity Range	-40 to +105°C (Note 1) 20 to 80%
	Voltage Rating	AC/DC 350V	Storage Temperature Range Storage Humidity Range	-10 to +60°C (Note 2) 40 to 70% (Note 2)

Item	Specifications	Conditions
1. Insulation resistance	1000MΩ min.	Measured at DC 500V
2. Withstand voltage	No flashover or breakdown	AC 1,200V is applied for 1 minute.
3. Contact resistance	10mΩ max.	Measured at 1mA and no higher than 20mV
4. Vibration Resistance	No electrical discontinuity for 1μs or longer	10 cycles in each of three directions at frequency 10-55 Hz, half amplitude 0.75mm
5. Shock Resistance	No electrical discontinuity for 1μs or longer	Accelerated velocity : 490m/s <sup>2</sup> , for 11ms, half-sine in 3 directions, 3 times for each of the three directions
6. Moisture-resistance	Contact resistance : 20mΩ max. Insulation resistance : 500MΩ min.	Temperature : 40±2°C ; humidity : 90 to 95%, left as it is for 96 hours
7. Temperature cycles	Contact resistance : 20mΩ max. Insulation resistance : 500MΩ min.	-55°C : 30 minutes → 5 - 35°C : 2 - 3 minutes → 105°C : 30 minutes → 5 - 35°C : 2 - 3 minutes) 5 cycles
8. Durability	Contact resistance : 20mΩ max.	30 mating cycles
9. Resistance to solder heat	The resin components will not become deformed or lose performance due to deformities	Reflow : according to the recommended temperature profile Hand soldering : temperature of soldering iron at 350°C±10°C for 3 seconds

Note 1 : Includes the temperature rise caused by current flow.

Note 2 : The storage condition refers to long-term storage of the product on the shelf before assembly. Please use the operating temperature for temporary storage such as pre-assembly and during shipping.

## Materials / Finish

Product	Part	Materials	Finish	UL specification
Header	Insulator	LCP	Natural	UL94V-0
	Contact	Brass	Tin Plated	-
Crimp socket	Insulator	LCP	Natural	UL94V-0
Crimp contact	Contact	Copper Alloy	Tin Plated	-

## Product Number Structure

Refer to the chart below when determining the product specifications from the product number.

Please select from the product numbers listed in this catalog when placing orders.

### Header connector

**DF 61Y - \* P - 2.2 V**

① ② ③ ④ ⑤ ⑥

① Series Name : DF	⑤ Pitch : 2.2mm
② Series No. : 61Y	⑥ Mounting style V : SMT Vertical Type
③ Number of contacts : 2	
④ Connector type P : Header	

### Socket connector

**DF 61Y - \* S - 2.2 C**

① ② ③ ④ ⑤ ⑥

① Series Name : DF	⑤ Pitch : 2.2mm
② Series No. : 61Y	⑥ Termination form C : crimp socket
③ Number of contacts : 2	
④ Connector type S : socket	

### Crimp contact

**DF 65 - 2428 SCF**

① ②

① Applicable wire size 2428 : 24 to 28 AWG	② Packaging style SCF : Socket contact•Reel
---	--

## ■ Straight pin header (SMT)

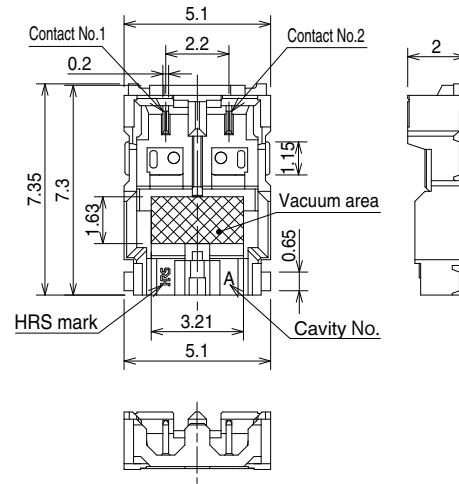

### ● Recommended PCB layout (t=1mm)

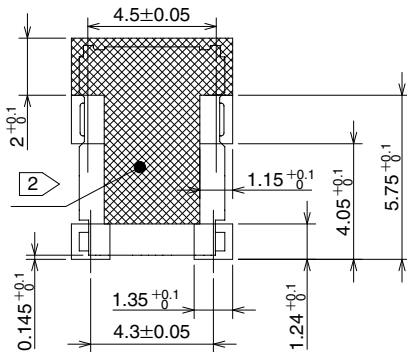

Part No.	HRS No.	No. of Contacts	Color	[Specification Number]**
DF61Y-2P-2.2V(23)	666-5100-3 23	2	Natural	(23) : Tin plated, embossed packaging

Note 1 : This product is sold per reel with 3,000 connectors pcs/reel. Please order by reel quantities.

② If the area contains a pattern and used at the rated voltage of 350V, the creepage distance could be insufficient.

### ● Tape and Reel Dimensions

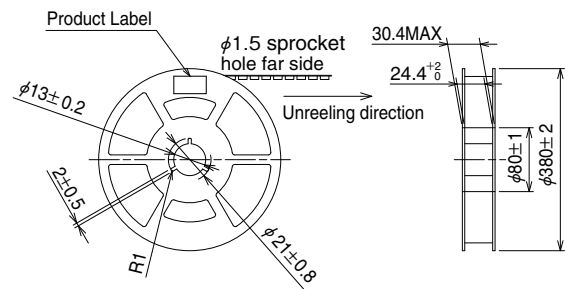
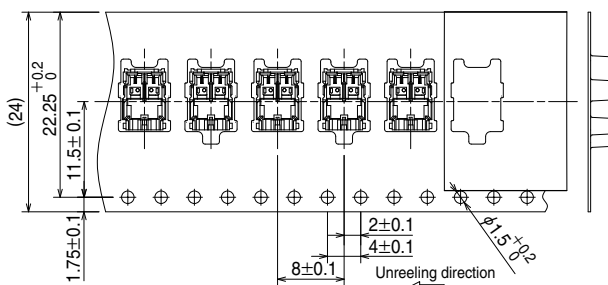

### ■ Crimp socket

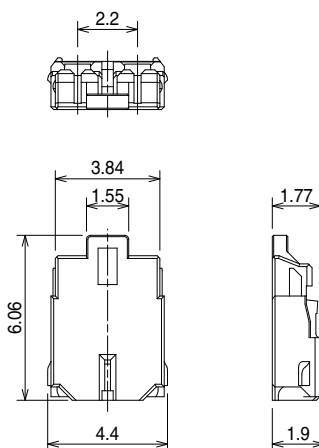

Part No.	HRS No.	No. of Contacts	Color	[Specification Number]**
DF61Y-2S-2.2C (13)	666-5101-6 13	2	Natural	(13) : 1,000 pcs/pack

Note : Each package contains 1,000 pcs/pack. Please order in full package quantities.

### ■ Crimp contact

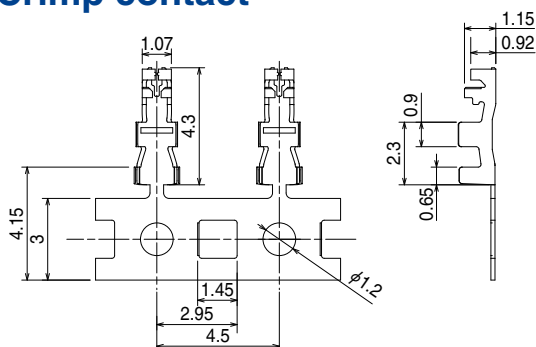

Part No.	HRS No.	Packaging	Quantity	Finish
DF65-2428SCF	666-6003-2 00	Reel (Note 1)	18,000	Tin plated

Note 1 : This product is delivered in 18,000 pieces per reels. Please place orders in multiples of 18,000 pieces.

### ● Applicable wire (Tin plated annealed copper wire)

Wire size (Stranded wire conductor)	Jacket outer diameter	Recommended cable	Strip length
24AWG (11/φ0.16mm)	φ1.11mm	UL10368	1.4 to 1.8mm
26AWG (7/φ0.16mm)	φ0.98mm		
28AWG (7/φ0.127mm)	φ0.88mm		

Note 1 : When using other than the recommended wire, contact your nearest Hirose sales representative.

Note 2 : The strip length is a reference value. Please make adjustments so finished crimps will meet the specified values. Refer to the crimping quality standards (ATAD-H0733-00) for details.

### ■ Tools

Type	Part No.	HRS No.	Applicable contact
Applicator	AP105-DF65-2428S	901-4630-0 00	DF65-2428SCF
Press	CM-105C	901-0001-0 00	
Hand crimping tool	HT305/DF65-2428S	550-0306-8 00	
Contact extraction tool	DF-C-PO(B)	550-0179-2 00	

Note : If any trouble has occurred due to tools other than the designated tool, Hirose bears no responsibility for any trouble.

## ◆ Operating Precautions

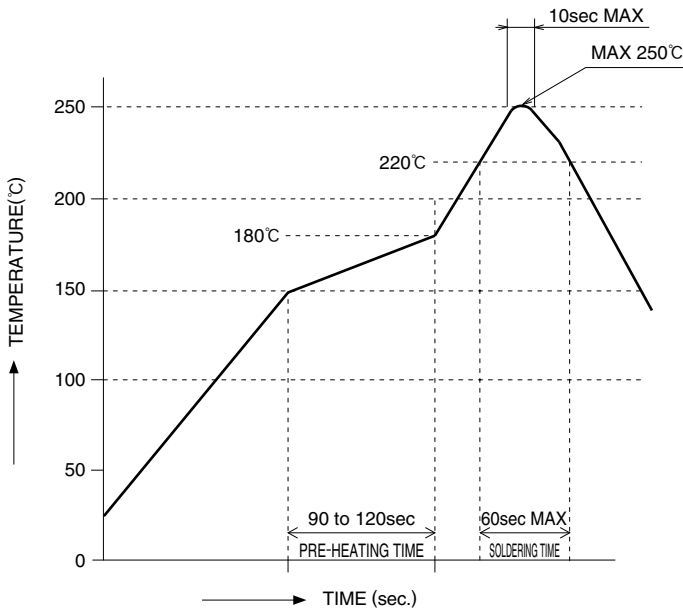
<p>1. Recommended Temperature Profile (Lead-free soldering possible)</p>	 <p><b>[Applicable Conditions]</b></p> <ol style="list-style-type: none"> <li>1. Peak Temperature : MAX 250°C</li> <li>2. Heated Area : 220°C or above, within 60 sec.</li> <li>3. Pre-heating Area : 150 to 180°C, 90 to 120 sec.</li> <li>4. Number of Operation : Twice or less</li> </ol> <p>* The contact lead area was measured.</p> <p>The conditions may change depending on the types and manufacturers of cream solder, PCB size, and conditions of other materials used for soldering. Please fully check the soldering condition before use.</p> <p>[Remarks 1] This temperature profile is our recommended value.</p>
<p>2. Recommended Hand Solder Conditions</p>	<p>Soldering iron temperature : <math>350 \pm 10^\circ\text{C}</math>, soldering time : within 3 seconds</p>
<p>3. Recommended Screen Thickness, Aperture Opening Rate (Pattern Area Ratio)</p>	<p>Thickness 0.1mm, aperture opening rate : 100%</p>
<p>4. PCB Warpage</p>	<p>0.02mm Max at the center of connector with the both edges of the connector as the baseline</p>
<p>5. Cleaning Condition</p>	<p>Cleaning with IPA is possible. (Cleaning is not recommended as it may change the feel of insertion/extraction, etc. Please consult with us when using other types of cleaning agents.)</p>
<p>6. Precautions</p>	<ul style="list-style-type: none"> <li>■ Insertion/extraction of the connector while not mounted to the PCB may cause breakage or deformation to the contact.</li> <li>■ Do not apply flux at the time of hand soldering, as it may result in flux rise.</li> <li>■ This product may have slightly different hue on molded items, however, they do not affect the product performance.</li> <li>■ See the separate “DF61Y Insertion/Extraction Procedure Manual” for handling precautions at the time of insertion and extraction.</li> </ul>

## ◆ Usage Recommendations

### 7. Insertion and removal operation

#### Insertion operation

Insertion operation shall be carried out in steps (1) placing the crimp socket, (2) insertion, and (3) check the mated state.

#### (1) Placing the crimp socket

Place the crimp socket so that the friction locks in 4 places in front and behind the crimp socket come into contact with the header.

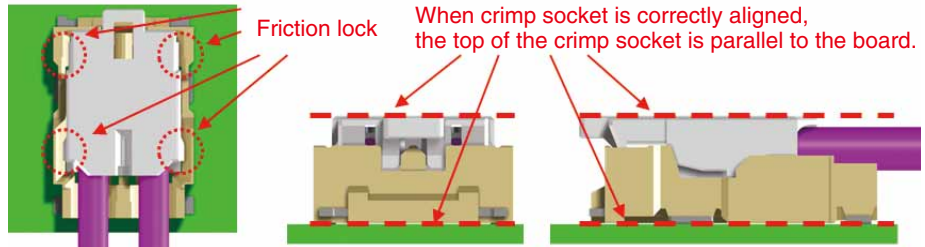

#### (2) Insertion

Press down on the center of the crimp socket, and mating is complete.

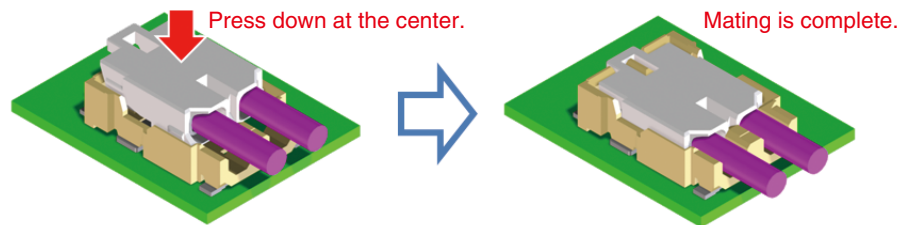

#### (3) Checking the mated state

Check if the crimp socket is securely mated.

If one end floats or is mated at an angle, unmate, and mate it again.

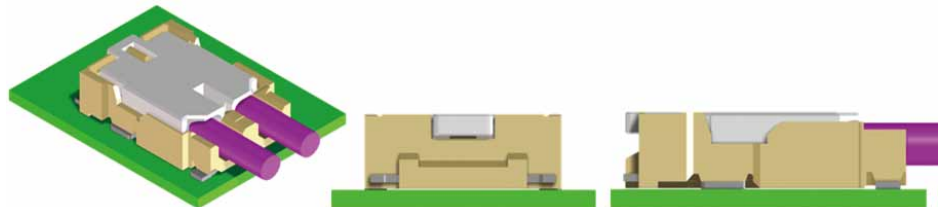

When the crimp socket is inserted, it is possible that only the friction lock on the cable side is inserted, as shown in the Figure below.

In this case, push the non-cable side of the crimp socket to correctly mate.



If the connector is inserted when the crimp socket isn't placed correctly, it is possible that only the friction lock on the non-cable side is inserted, as shown in the Figure below.

In this case, unmate, and mate again.

Forcible mating will lower the retention force.

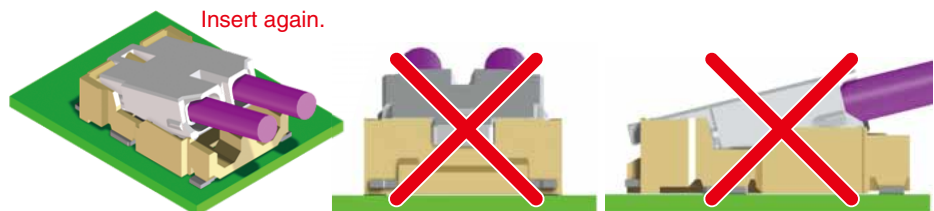

7. Insertion and removal operation

If the connector is inserted when the crimp socket isn't placed correctly, it is possible that only the friction lock on the non-cable side is inserted, as shown in the Figure below. In this case, unmate, and mate again. Forcible mating will lower the retention force.

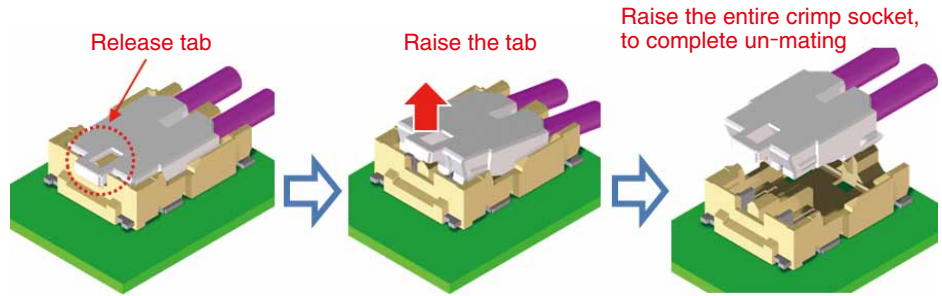

Use the tab to help release .  
If the connector is forcibly removed by pulling the cable, cable disconnection and connector breakage will occur.





**USA:**

**HIROSE ELECTRIC (U.S.A.), INC. HEADQUARTERS CHICAGO OFFICE**  
2300 Warrenville Road, Suite 150,  
Downers Grove, IL 60515  
Phone : +1-630-282-6700  
<http://www.hirose.com/us/>

**USA:**

**HIROSE ELECTRIC (U.S.A.), INC. SAN JOSE OFFICE**  
2841 Junction Ave, Suite 200  
San Jose, CA. 95134  
Phone : +1-408-253-9640  
Fax : +1-408-253-9641  
<http://www.hirose.com/us/>

**USA:**

**HIROSE ELECTRIC (U.S.A.), INC. DETROIT OFFICE (AUTOMOTIVE)**  
17197 N. Laurel Park Drive, Suite 253,  
Livonia, MI 48152  
Phone : +1-734-542-9963  
Fax : +1-734-542-9964  
<http://www.hirose.com/us/>

**THE NETHERLANDS:**

**HIROSE ELECTRIC EUROPE B.V.**  
Hogehillweg #8 1101 CC Amsterdam Z-O  
Phone : +31-20-6557460  
Fax : +31-20-6557469  
<http://www.hirose.com/eu/>

**GERMANY:**

**HIROSE ELECTRIC EUROPE B.V. GERMAN BRANCH**  
Schoenbergstr. 20, 73760 ostfildern  
Phone : +49-711-456002-1  
Fax : +49-711-456002-299  
<http://www.hirose.com/eu/>

**GERMANY:**

**HIROSE ELECTRIC EUROPE B.V. NUREMBERG OFFICE**  
Neumeyerstrasse 22-26, 90411 Nurnberg  
Phone : +49-911 32 68 89 63  
Fax : +49-911 32 68 89 69  
<http://www.hirose.com/eu/>

**GERMANY:**

**HIROSE ELECTRIC EUROPE B.V. HANOVER OFFICE**  
Bayernstr. 3, Haus C 30855 Langenhagen, Germany  
Phone : +49-511 97 82 61 30  
Fax : +49-511 97 82 61 35  
<http://www.hirose.com/eu/>

**FRANCE:**

**HIROSE ELECTRIC EUROPE B.V. PARIS OFFICE**  
Regus La Garenne Colombes, Place de La Belgique,  
71 Boulevard National La Garenne Colombes, 92250, France  
Phone : +33 (0) 1 7082 3170  
Fax : +33 (1) 7082 3101  
<http://www.hirose.com/eu/>

**UNITED KINGDOM:**

**HIROSE ELECTRIC EUROPE BV (UK BRANCH)**  
4 Newton Court, Kelvin Drive, Knowlhill,  
Milton Keynes, MK5 8NH  
Phone : +44-1908 202050  
Fax : +44-1908 202058  
<http://www.hirose.com/eu/>

**CHINA:**

**HIROSE ELECTRIC (SHANGHAI) CO., LTD.**  
1601, Henderson Metropolitan, NO.300, East Nanjing  
Road, Huangpu District, Shanghai, China 200001  
Phone : +86-21-6391-3355  
Fax : +86-21-6391-3335  
<http://www.hirose.com/cn/>

**CHINA:**

**HIROSE ELECTRIC (SHANGHAI) CO.,LTD. BEIJING BRANCH**  
A1001, Ocean International Center, Building 56# East 4th  
Ring Middle Road, ChaoYang District, Beijing, 100025  
Phone : +86-10-5165-9332  
Fax : +86-10-5908-1381  
<http://www.hirose.com/cn/>

**CHINA:**

**HIROSE ELECTRIC TECHNOLOGIES (SHENZHEN) CO., LTD.**  
Room 09-13, 19/F, Office Tower Shun Hing Square, Di Wang Commercial Centre,  
5002 Shen Nan Dong Road, Shenzhen City, Guangdong Province, 518008  
Phone : +86-755-8207-0851  
Fax : +86-755-8207-0873  
<http://www.hirose.com/cn/>

**HONG KONG:**

**HIROSE ELECTRIC HONGKONG TRADING CO., LTD.**  
Room 1001, West Wing, Tsim Sha Tsui Centre, 66  
Mody Road, Tsim Sha Tsui East, Kowloon, Hong Kong  
Phone : +852-2803-5338  
Fax : +852-2591-6560  
<http://www.hirose.com/hk/>

**TAIWAN:**

**HIROSE ELECTRIC TAIWAN CO., LTD.**  
103 8F, No.87, Zhengzhou Rd., Taipei  
Phone : +886-2-2555-7377  
Fax : +886-2-2555-7350  
<http://www.hirose.com/tw/>

**KOREA:**

**HIROSE KOREA CO.,LTD.**  
250, Huimanggongwon-ro, Siheung-si,  
Gyeonggi-do, Korea, 15083  
Phone : +82-31-496-7000 or 7124  
Fax : +82-31-496-7100  
<http://www.hirose.co.kr/>

**SINGAPORE:**

**HIROSE ELECTRIC SINGAPORE PTE. LTD.**  
10 Anson Road #26-16, International Plaza  
079903, Singapore  
Phone : +65-6324-6113  
Fax : +65-6324-6123  
<http://www.hirose.com/sg/>

**INDIA:**

**HIROSE ELECTRIC SINGAPORE PTE. LTD. DELHI LIAISON OFFICE**  
Office NO.552, Regus-Green Boulevard, Level5, Tower C,  
Sec62, Plot B-9A, Block B, Noida, 201301, Uttar Pradesh, India  
Phone : +91-12-660-8018  
Fax : +91-120-4804949  
<http://www.hirose.com/sg/>

**INDIA:**

**HIROSE ELECTRIC SINGAPORE PTE. LTD. BANGALORE LIAISON OFFICE**  
Unit No-403, 4th Floor, No-84, Barton Centre, Mahatma  
Gandhi (MG) Road, Bangalore 560 001, Karnataka, India  
Phone : +91-80-4120 1907  
Fax : +91-80-4120 9908  
<http://www.hirose.com/sg/>

**MALAYSIA:**

**PENANG REPRESENTATIVE OFFICE**  
1-21-01, Suntech @ Penang Cybercity (1164), Lintang  
Mayang Pasir 3,11950, Bayan Baru, Penang, Malaysia.  
Phone : +604-619-2564  
Fax : +604-619-2574  
<http://www.hirose.com/sg/>

**THAILAND:**

**BANGKOK OFFICE (REPRESENTATIVE OFFICE)**  
Unit 4703, 47th FL., 1 Empire Tower, South Sathorn  
Road, Yannawa, Sathorn, Bangkok 10120 Thailand  
Phone : +66-2-686-1255  
Fax : +66-2-686-3433  
<http://www.hirose.com/sg/>

**HIROSE ELECTRIC CO.,LTD.**

2-6-3, Nakagawa Chuoh, Tsuzuki-Ku, Yokohama-Shi 224-8540, JAPAN  
TEL: +81-45-620-3526 Fax: +81-45-591-3726  
<http://www.hirose.com>  
<http://www.hirose-connectors.com>