

### Feature

- 200 amps continuous carry, 2000 amps interrupte under extreme condition.
- Hermetically sealed with hydrogen gas, the arc is not exposed. Be able to use in explosive & harsh environments without oxidation or contamination of contacts. Contacts' part meet IP67 protection degree.
- With energy-saving coil circuit, the nominal power is only 2.0W, broad coil voltage: 12 ~ 24VDC.
- RoHS compliant.

### Contact Data

Item	Information		
Contact arrangement	1 Form A contact		
Current rating	300A		
Contact resistance	≤0.5mΩ(@6V 20A)		
Min.Switching load	1A 12VDC		
Outgoing Mode	M8 External Thread		
	500V type	750V type	
Max. Switching voltage	750VDC	900VDC	
Max. Connecting current	2400A ( 500VDC, 1 cycle )	2400A ( 750VDC, 1 cycle )	
Max. Breaking current	3000A ( 500VDC, 1 cycle )	2000A ( 750VDC, 1 cycle )	
Max. Switching power	150KW	225KW	
Electrical life <sup>(1)</sup>	Capacitive load	25,000cycles ( 22.5VDC, τ=1ms inrush400A , steady300A )	15,000次 ( 37.5VDC, τ=1ms inrush400A , steady300A )
	Resistive load	10,000cycles ( 500VDC 80A )	10,000cycles ( 750VDC 80A )
	Resistive load	3,000cycles ( 500VDC 300A ) 1,500cycles ( 500VDC -300A )	1,000cycles ( 750VDC 300A ) 500cycles ( 750VDC -300A )
Load current capacity <sup>(2)</sup>	300A : continuity		
	450A : 60min.		
	600A : 20min.		
	1200A : 30s		
	3000A : 0.6s		

#### NOTES :

( 1 ) Ambient temperature: 23°C , L/R ≤ 1ms.

( 2 ) Ambient temperature: 23°C , 100mm<sup>2</sup> conductor.

( 3 ) Other types of rated voltage, please contact us.

### Parameters Table

Item	Information	
Mechanical life	5 × 10 <sup>5</sup> cycles	
Insulation resistance	1000MΩ(500VDC)	
Dielectric strength	Between open contacts	3000VAC 1min 10mA
	Between contact and coil	4000VAC 1min 10mA
Operate time (at rated coil voltage)	≤50ms	
Release time (at rated coil voltage)	≤30ms	
Shock resistance	Functional	196m/s <sup>2</sup> ( 20G )
	Destructive	490m/s <sup>2</sup> ( 50G )
Vibration resistance	10Hz~500Hz 49m/s <sup>2</sup> ( 5G )	
Ambient temperature	-40°C~85°C	
Ambient humidity	5%~95% RH	
Weight	730g	
External dimension	113.5×65×75.5	

### Coil Data<sup>(3)</sup>

Model	SEV300-XMLXXX
Rated voltage ( VDC )	12 ~ 24
Max. voltage ( VDC )	24
Pick-up voltage ( VDC )	≤9
Drop-out voltage ( VDC )	≥1
Coil resistance(±10%)(Ω)	3.4
Operating power ( inrush , W )	42
Operating power ( stable , W )	2.0

Reference Data

Load capacity

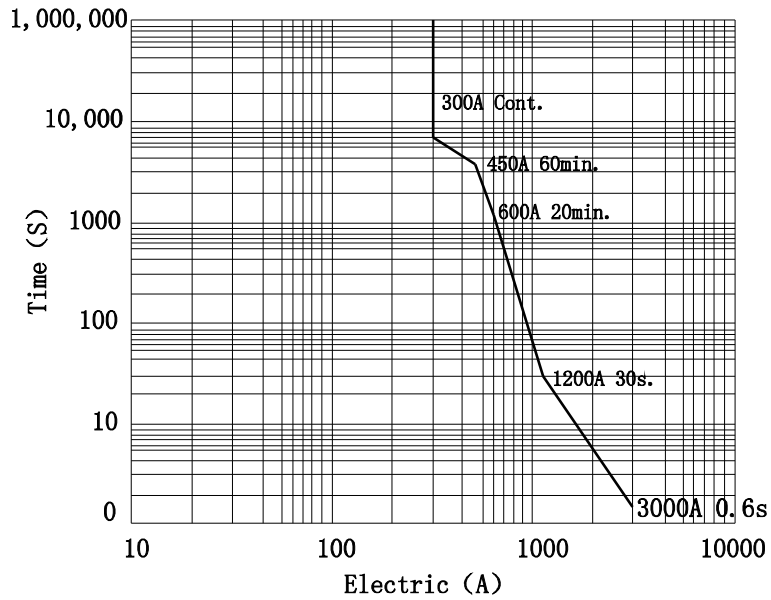

Ordering Information

Nomenclature						
<b>SEV</b>	<b>300</b>	-	<input type="checkbox"/>	<b>M</b>	<input type="checkbox"/>	<input type="checkbox"/>
				<b>Customer features label:</b> <b>Nil:</b> No Customer special requirements <b>Numbers or Letters:</b> Customer special requirements		
				<b>Load connection type:</b> <b>1:</b> connection piece+external thread <b>2:</b> internal thread		
				<b>Coil connection type: Nil:</b> outgoing line+connector		
				<b>Coil Voltage (VDC) : L:</b> 12~24VDC		
				<b>Contact arrangement M :</b> 1 Form A		
				<b>Voltage rating 750 :</b> 12~750VDC <b>500 :</b> 12~500VDC		
				<b>Load current 300 :</b> 300A		
				<b>Type designation SEV</b>		

Packing quantity:1pcs inner carton, 10pcs outer carton

Outline Dimensions Of The Normal Products

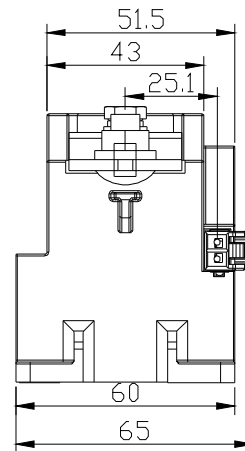
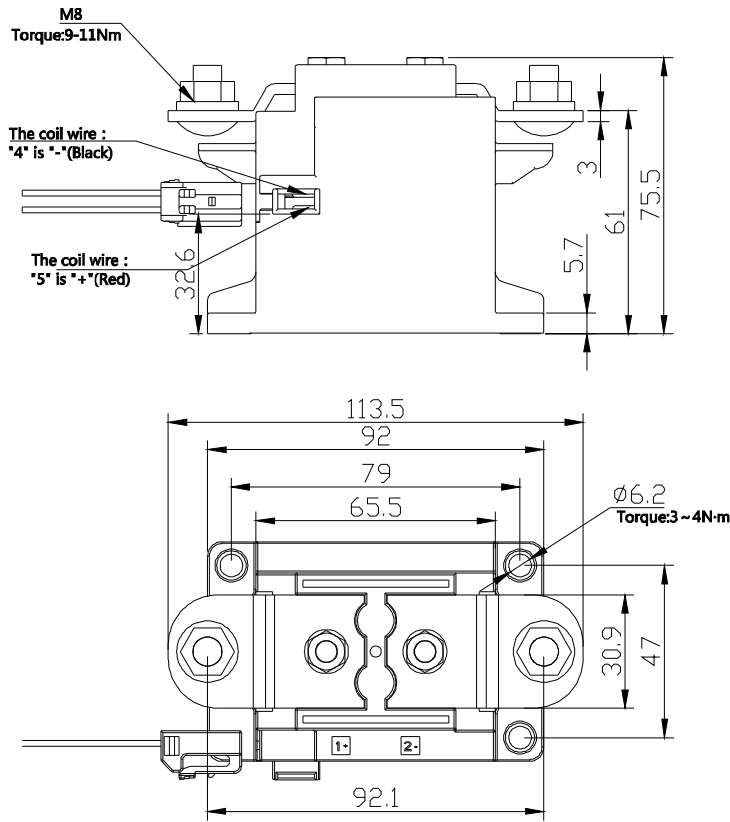

Size	tolerance
Less than 10mm:	±0.3
10 to 50mm:	±0.5
More than 50mm:	±0.8

Outline Dimensions Of The Load Connection Type Is Internal Thread

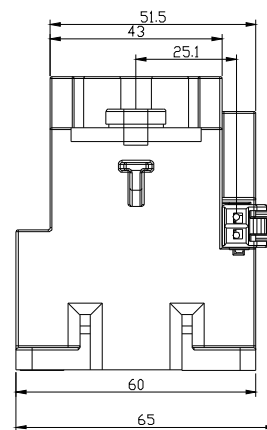
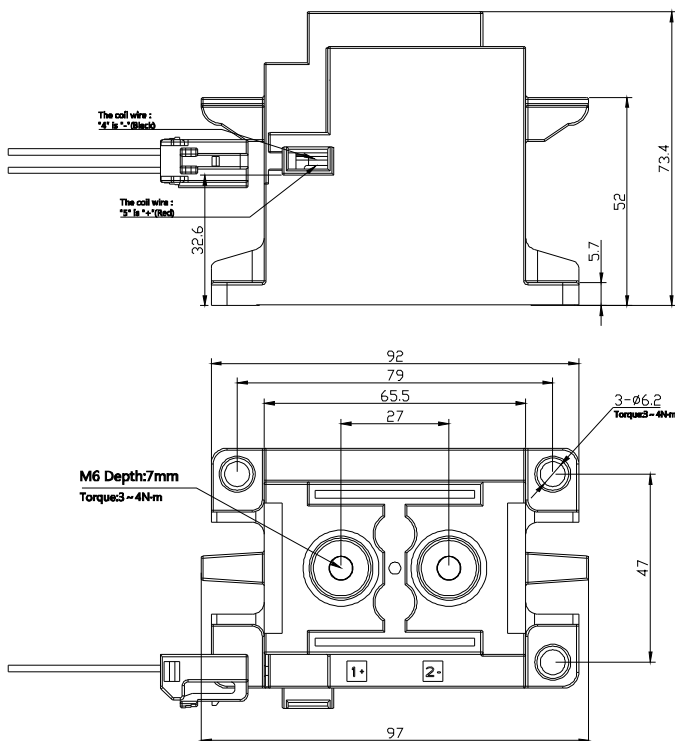

Size	tolerance
Less than 10mm:	±0.3
10 to 50mm:	±0.5
More than 50mm:	±0.8

Installation Size Chart

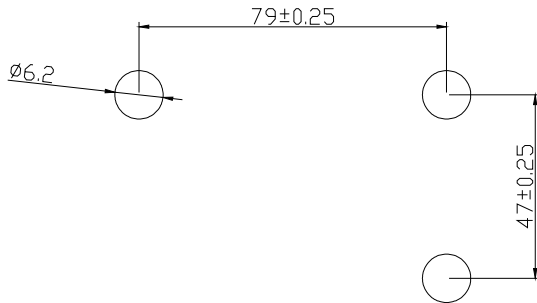

Schematic Diagram

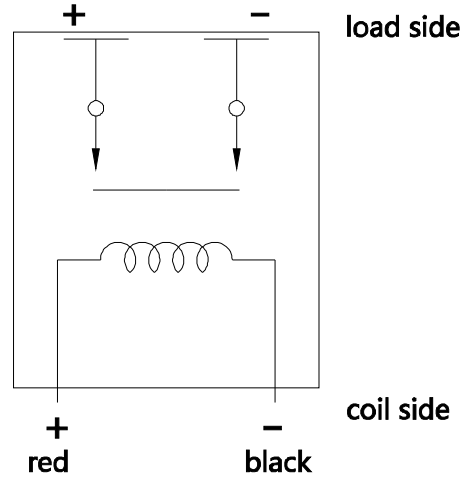

Coil Connection Type

Connectors : Tian Hai :0435305 or Yazaki : 7283-1020(included in the box )

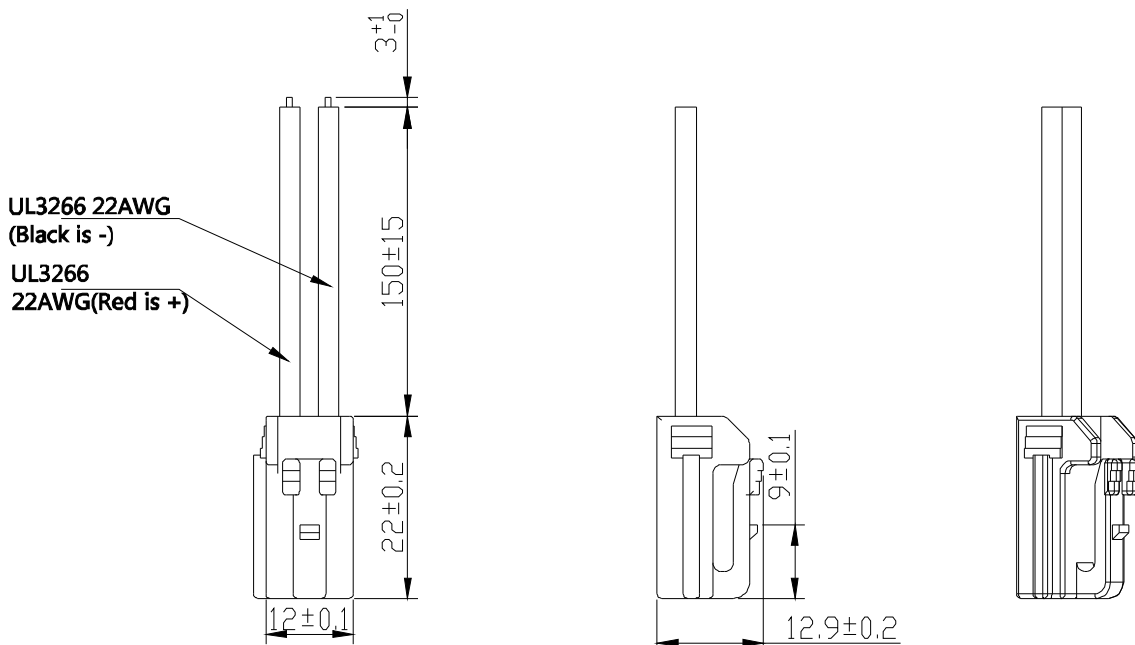

**NOTES****●Mounting Attention**

1. When installing the relay, always use washers to prevent the screws from loosening.
2. Tighten each screw within the rated range given in the outline dimensions. Exceeding the maximum torque may result in breakage.
3. Avoid mounting the relay in strong magnetic fields (near a transformer or magnet) or close to an object that radiates heat.

**●Electrical Life Attention**

1. This relay is a DC high-voltage switch. In its final breakdown mode, it may lose the ability to provide the proper cut-off. Therefore, do not exceed the indicated switching capacity and life.
2. Please treat the relay as a product with limited life and replace it when necessary.
3. The contacts of the relay are polarized. Please follow instructions in the connection schematic when connecting the contacts.
4. Be careful that foreign matter and oils and fats kind, don't stick to the main terminal parts because it is likely to cause terminal parts to give off unusual heat. Also, please use the following specifications of conductor.

10A	Min. 2mm <sup>2</sup> nominal cross-sectional area
20A	Min. 3mm <sup>2</sup> nominal cross-sectional area
40A	Min. 10mm <sup>2</sup> nominal cross-sectional area
60A	Min. 15mm <sup>2</sup> nominal cross-sectional area
100A	Min. 35mm <sup>2</sup> nominal cross-sectional area
150A	Min. 45mm <sup>2</sup> nominal cross-sectional area
200A	Min. 60mm <sup>2</sup> nominal cross-sectional area
250A	Min. 80mm <sup>2</sup> nominal cross-sectional area
300A	Min. 100mm <sup>2</sup> nominal cross-sectional area

**●Coil Attention**

1. Please note that when using a diode, the switching speed may decrease and cause a reduction in cut-off performance, we recommend installing a surge protector varistor.
2. The pick-up voltage and drop-out voltage will change with ambient temperature, please use rated voltage to make sure the relay operate reliable. Don't exceed maximum coil voltage.
3. The 250A and 300A types have built-in dedicated drive circuit, please drive the coil with a quick startup (Built-in one-shot pulse generator circuit).
4. After the ON signal enters the 250A and 300A types, automatic coil current switching occurs after approximately 0.1 seconds. Do not repeatedly turn it OFF within that 0.1 seconds interval, as doing so may damage the relay.

**Disclaimer :**

This datasheet is the customers' reference. All the specification are subject to change without notice.  
We could not evaluate all the performance and parameters for every possible application. Thus the users should be in a right position to choose the suitable product for their own application. If there is any query, please contact Sanyou for technical service. However it is the users' responsibility to determine which product should be used only.  
SANYOU CORPORATION LIMITED. All rights reserved by Sanyou.