

**PLEASE CHECK WWW.MOLEX.COM FOR LATEST PART INFORMATION**

**Part Number:** [0495181492](#)  
**Status:** **Active**  
**Description:** 3.96mm (.156") Pitch Wire-to-Board Retainer, 14 Circuits, UL94V-2, Red

**Documents:**

[Drawing \(PDF\)](#) [RoHS Certificate of Compliance \(PDF\)](#)  
[Product Specification PS-49517-001 \(PDF\)](#)

**General**

Product Family	Accessories
Series	49518
Component Type	Retainer
Product Name	TPA™ - Term Pos Assurance

**Physical**

Circuits (Loaded)	14
Color - Resin	Natural
Lock to Mating Part	Yes
Material - Resin	Nylon
Number of Rows	0
Packaging Type	Bag
Temperature Range - Operating	-25°C to +85°C

**Material Info**

**Reference - Drawing Numbers**

Packaging Specification	PK-49518-001
Product Specification	PS-49517-001
Sales Drawing	SD-49518-001

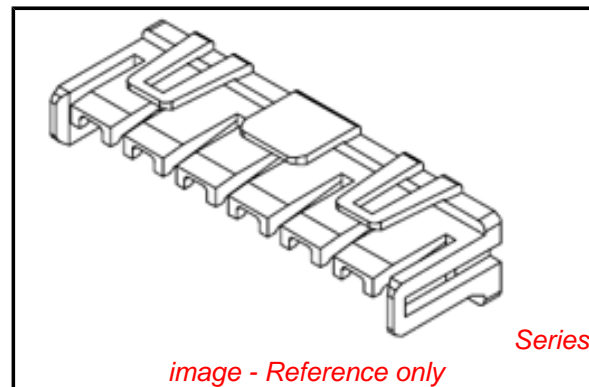

**EU RoHS**

**ELV and RoHS  
Compliant**  
**REACH SVHC**  
 Not Reviewed  
**Halogen-Free  
Status**  
 Not Reviewed

**China RoHS**



**Need more information on product  
environmental compliance?**

Email [productcompliance@molex.com](mailto:productcompliance@molex.com)  
 For a multiple part number RoHS Certificate of Compliance, [click here](#)

Please visit the [Contact Us](#) section for any non-product compliance questions.

**Search Parts in this Series**  
[49518Series](#)

**Use With**  
[49517 Wire-to-Board Female Housing](#)

DO NOT SCALE DRAWING DIMENSION IN METRIC

DWG. NO. SD-49518-001

SIMILAR ITEM

PROJECT NO.

B

REV

8 7 6 5 4 3 2 1

F  
E  
D  
C  
B  
A

TRADE MARK MK1

CAVITY NO. (1,2,3,...)

LOCKING "G"

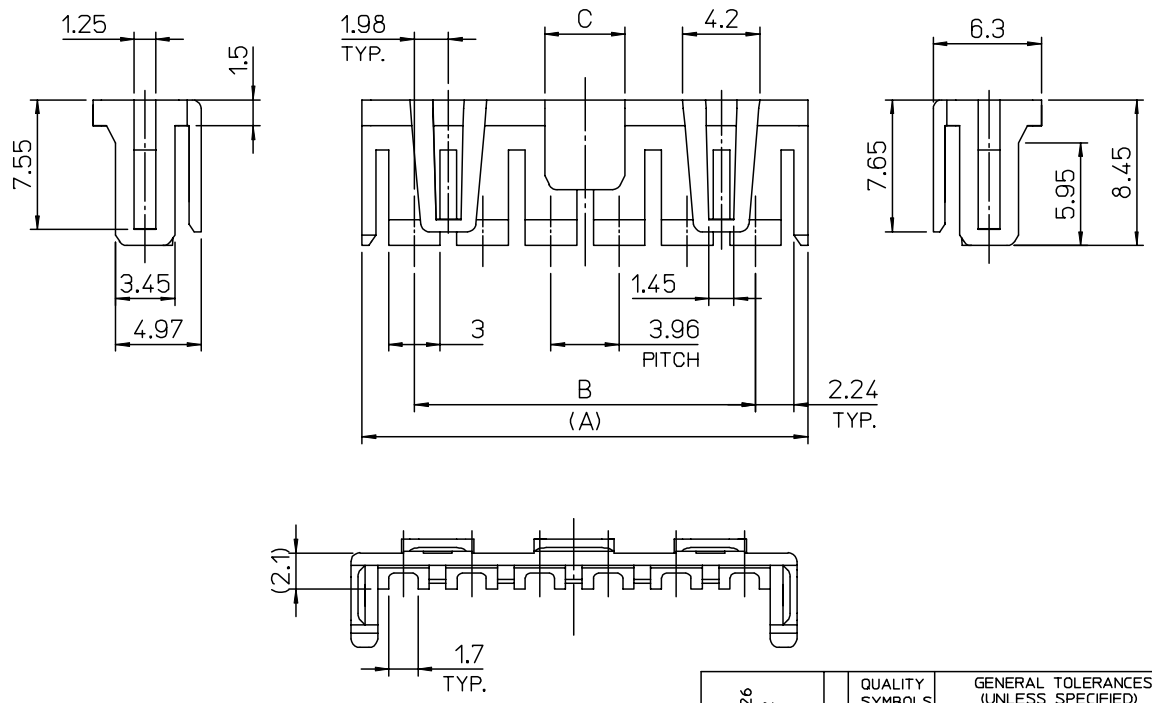
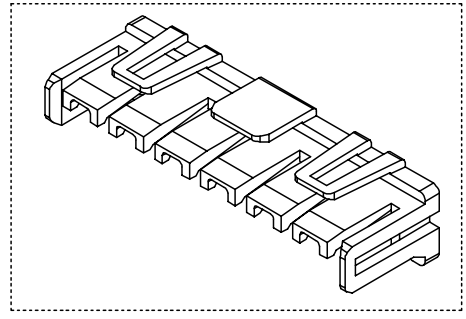

17.07	55.44	61.52	- 1590	15	LOCKING
	51.48	57.56	- 1490	14	
	47.52	53.6	- 1390	13	
	43.56	49.64	- 1290	12	
	39.60	45.68	- 1190	11	
	35.64	41.72	- 1090	10	
14.87	31.68	37.76	- 0990	9	
12.87	27.72	33.8	- 0890	8	
8.04	23.76	29.84	- 0790	7	
4.67	19.80	25.88	- 0690	6	WITHOUT LOCKING
	15.84	21.92	- 0590	5	
	11.88	17.96	- 0490	4	
	7.92	14	- 0390	3	
0.67	3.96	10.04	49518- 0290	2	
C	B	A	MATERIAL NO.	CKT'	TYPE'G'

NOTES

- MATERIAL : POLYAMIDE66,UL94V-2
- FINISH : NATURAL COLOR
- MATED WITH HOUSING : 49517 SERIES

NEW RELEASED ECN NO. KOR2006-0026 DRWN: J.B.JIN 05/08/22 CHK: W.Y.YANG APPR: C.W.LEE	DESCRIPTION MAJOR CRITICAL C	QUALITY SYMBOLS		GENERAL TOLERANCES: (UNLESS SPECIFIED)		SCALE 1:1	DESIGN UNITS <input checked="" type="checkbox"/> mm <input type="checkbox"/> INCH	THIRD ANGLE PROJECTION <input type="checkbox"/> mm <input checked="" type="checkbox"/> INCH		SHT	REV
		4 PLACES	±0.	±-	mm	INCH	DRAWN BY & DATE J.B.JIN 05/02/18		TITLE: 3.96 W/B CONN.-TPA		
		3 PLACES	±0.	±-	mm	INCH	CHECKED BY & DATE W.Y.YANG 05/02/18		MOLEX INCORPORATED		
		2 PLACES	±0.25	±-	mm	INCH	APPROVED BY & DATE C.W.LEE 05/02/18		CAD FILENAME S49518AA.MI	MATERIAL NO. SEE CHART	DRAWING NO. SD-49518-001
1 PLACE	±0.25	±-	mm	INCH	ANGULAR: ± °		DRAFT WHERE APPLICABLE MUST REMAIN WITHIN DIMENSIONS		THIS DRAWING CONTAINS INFORMATION THAT IS PROPRIETARY TO MOLEX INCORPORATED AND SHOULD NOT BE USED WITHOUT WRITTEN PERMISSION.		
A	REV									KOREA MX-A3	

8 7 6 5 4 3 2 1 KOREA MX-A3