

Rack-mounted DCS Signal Conditioners 18-RACK

THERMOCOUPLE CONVERTER

Functions & Features

- Accepting direct input from a thermocouple and providing two standard process signals
- 5-segment linearization
- Burnout protection
- High-accuracy cold junction compensation
- Second channel output available at the front terminals and at the Standard Rack connector

Typical Applications

- High-accuracy cold junction compensation benefits narrow span measurements
- 0.1 μ A burnout sensing enables long distance transmission with minimum offset drifts
- Electric furnace (isolation)
- No burnout type can connect to a single T/C in parallel with a recorder

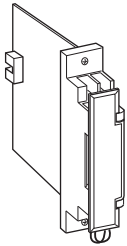

MODEL: 18TS-[1]6[2]-R[3]

ORDERING INFORMATION

- Code number: 18TS-[1]6[2]-R[3]
- Specify a code from below for each of [1] through [3].
(e.g. 18TS-266-R/BL)
- Temperature range (e.g. 0 - 800°C)

[1] INPUT THERMOCOUPLE

- 1: (PR) (Usable Range 0 to 1760°C, 32 to 3200°F)
- 2: K (CA) (Usable range -270 to +1370°C, -454 to +2498°F)
- 3: E (CRC) (Usable range -270 to +1000°C, -454 to +1832°F)
- 4: J (IC) (Usable range -210 to +1200°C, -346 to +2192°F)
- 5: T (CC) (Usable range -270 to +400°C, -454 to +752°F)
- 6: B (RH) (Usable range 0 to 1820°C, 32 to 3308°F)
- 7: R (Usable range -50 to +1760°C, -58 to +3200°F)
- 8: S (Usable range -50 to +1760°C, -58 to +3200°F)
- N: N (Usable range -270 to +1300°C, -454 to +2372°F)
- 0: Specify

OUTPUT 1

Voltage

6: 1 - 5 V DC (Load resistance 2000 Ω min.)

[2] OUTPUT 2

Current

A: 4 - 20 mA DC (Load resistance 600 Ω max.)

Voltage

6: 1 - 5 V DC (Load resistance 2000 Ω min.)

POWER INPUT

DC Power

R: 24 V DC

(Operational voltage range 24 V \pm 10 %, ripple 10 %p-p max.)

[3] OPTIONS

Burnout

blank: Upscale burnout

/BL: Downscale burnout

/BN: No burnout

GENERAL SPECIFICATIONS

Construction: Rack-mounted; terminal access via screw terminals on the front and connector on the rear; terminal cover provided

Connection

Input: M3.5 screw terminals (torque 0.8 N·m)

Output 1: Connector

Output 2: M3.5 screw terminals (torque 0.8 N·m) and connector

Power input: Supplied from connector

Screw terminal: Nickel-plated steel

Isolation: Input to output 1 to output 2 to power

Overrange output: Approx. -10 to +120 % at 1 - 5 V

Zero adjustment: -5 to +5 % (front)

Span adjustment: 95 to 105 % (front)

Linearization: Standard

Cold junction compensation: CJC sensor attached to the input terminals

INPUT SPECIFICATIONS

Input resistance: 20 kΩ minimum

Burnout sensing: 0.1 μA

Minimum span: 3 mV

Offset: Max. 1.5 times span

Minimum span (in °C)

(PR): 370°C

K (CA): 75°C

E (CRC): 50°C

J (IC): 60°C

T (CC): 75°C

B (RH): 780°C

R: 360°C

S: 380°C

N: 110°C

Minimum span (in °F)

(PR): 670°F

K (CA): 140°F

E (CRC): 90°F

J (IC): 110°F

T (CC): 140°F

B (RH): 1410°F

R: 650°F

S: 690°F

N: 200°F

For the temperatures that range below 0°C, the transmitter may partially not satisfy the described accuracy. Consult factory.

INSTALLATION

Current consumption: Approx. 35 mA with voltage output

Approx. 65 mA with current output

Operating temperature: -5 to +55°C (23 to 131°F)

Operating humidity: 30 to 90 %RH (non-condensing)

Mounting: Standard Rack 18BXx or 18KBXx

Weight: 150 g (0.33 lb)

PERFORMANCE in percentage of span

Accuracy: ±0.4 % (at over 400°C or 750°F for R, S and PR; over 770°C or 1420°F for B)

Cold junction compensation error

(at 20°C ±10°C or 68°F ±18°F)

K, E, J, T, N: ±0.5°C or ±0.9°F

S, R, PR: ±1°C or ±1.8°F

Temp. coefficient: ±0.015 %/°C (±0.008 %/°F)

(at over 400°C or 750°F for R, S and PR; over 770°C or 1420°F for B)

Response time: ≤ 0.5 sec. (0 - 90 %)

Burnout response: ≤ 10 sec.

Line voltage effect: ±0.1 % over voltage range

Insulation resistance: ≥ 100 MΩ with 500 V DC

Dielectric strength: 1500 V AC @ 1 minute

(input to output 1 or output 2 or power)

500 V AC @ 1 minute

(output 1 to output 2 to power)

1500 V AC @ 1 minute

(input or output or power to ground)

EXTERNAL DIMENSIONS unit: mm (inch)

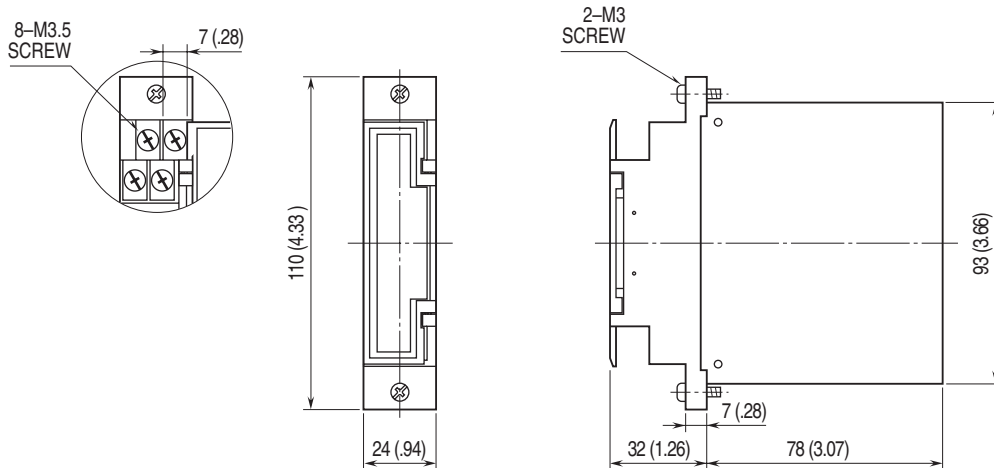

TERMINAL ASSIGNMENTS

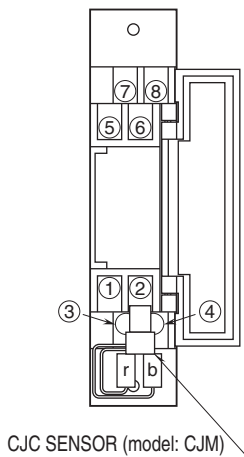

SCHEMATIC CIRCUITRY & CONNECTION DIAGRAM

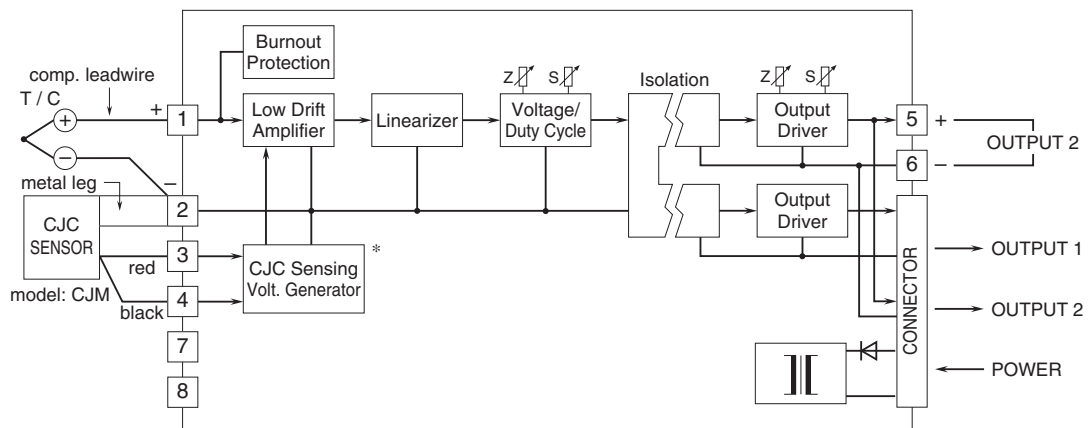

*Deleted with B thermocouple
 For OUTPUT 2 with current output, use either of terminals on the front or connector on the rear.



Specifications are subject to change without notice.