

Waterproof Small Type Tactile Switch STU Series

FEATURES

1. IP68 water resistance and dust resistance.
2. Actuator on the center of spring prevents deterioration of operating feel due to misalignment between switch and knob.
3. Sharp click feel and long operating life.

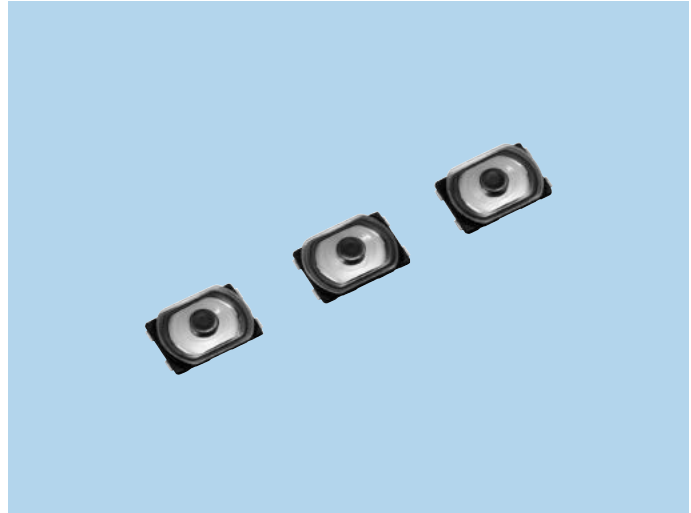

APPLICATIONS

1. Small electrical devices such as Mobile phones, Smart phones, Wearable devices.
2. The equipment to use in outdoor, use in dusty place.

MODEL NAME CODE

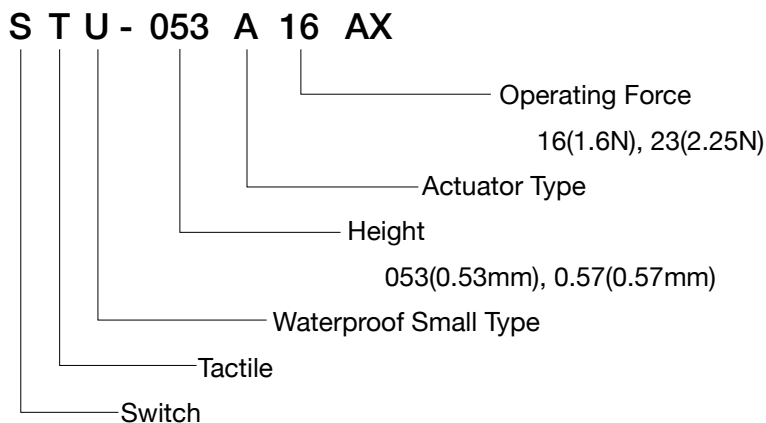

SPECIFICATIONS

Electrical Characteristics	Rating (Resistive load)	DC15V, 20mA (maximum)
		DC2V, 10 μ A (minimum)
	Contact Resistance	500m Ω or less
Life	STU-053A16AX	300,000 times
	STU-057A23AX	500,000 times
Water Resistance	Protective resistance	IP68

TYPE

Model Name Code	Model Name	Operating Force	Pcs/Reel
STU-053A16AX	R66 7963	1.6N	20,000
STU-057A23AX	R66 7966	2.25N	20,000

DIMENSIONS

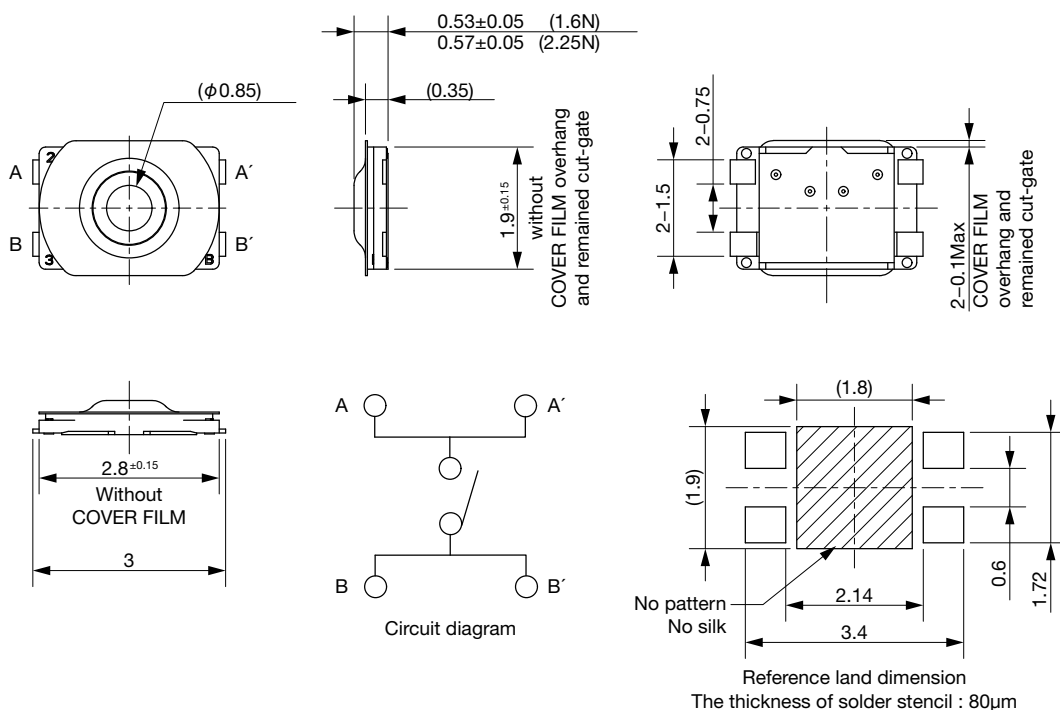

Unit: mm