

GHz BGA Socket - Direct mount, solderless

Features

- Directly mounts to target PCB (needs tooling holes) with hardware.
- High speed, reliable Elastomer connection
- Minimum real estate required
- Compression plate distributes forces evenly
- Easily removable swivel socket lid

Top View

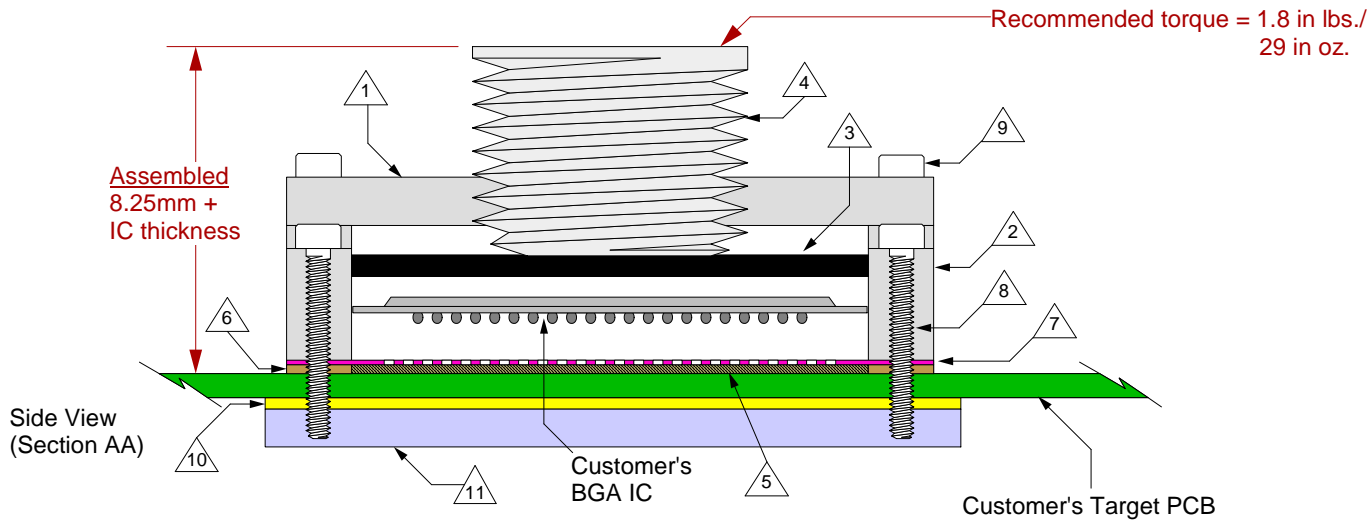
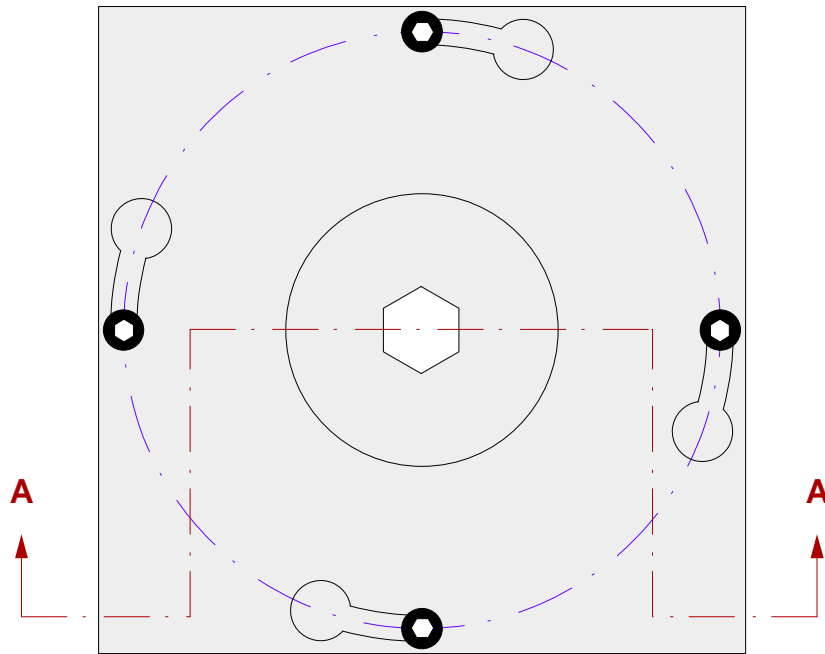

- △ 1 Socket Lid: Black anodized Aluminum. Thickness = 2.5mm.
- △ 2 Socket base: Black anodized Aluminum. Thickness = 5mm.
- △ 3 Compression Plate: Black anodized Aluminum. Thickness = 2.5mm.
- △ 4 Compression screw: Clear anodized Aluminum. Thickness = 5mm, Hex socket = 5mm.
- △ 5 Elastomer: 20 micron dia gold plated brass filaments arranged symmetrically in a silicone rubber (63.5 degree angle). Thickness = 0.5mm.
- △ 6 Elastomer Guide: Non-clad FR4. Thickness = 0.475mm.
- △ 7 Ball Guide: Kapton polyimide.
- △ 8 Socket base screw: Socket head cap, alloy steel with black oxide finish, 0-80 fine thread, 9.525mm long.
- △ 9 Socket lid screw: Shoulder screw, 18-8 SS, 0-80 fine thread.
- △ 10 Insulation Plate: FR4/G10, Thickness = 1.59mm.
- △ 11 Backing Plate: Black anodized Aluminum. Thickness = 6.35mm.

	SG-BGA-7034 Drawing		Status: Released	Scale: -	Rev: B
	© 2009 IRONWOOD ELECTRONICS, INC. 11351 Rupp Drive, Suite 400, Burnsville, MN 55337 Tele: (952) 229-8200 www.ironwoodelectronics.com		Drawing: H. Hansen		Date: 1/24/05
			File: SG-BGA-7034 Dwg	Modified: 6/12/09, AE	

All tolerances: ±0.125mm (unless stated otherwise). Materials and specifications are subject to change without notice.

***Note: BGA pattern is not symmetrical with respect to the mounting holes.**

Note: Full BGA pattern shown.
Please adjust pattern according to individual requirements.

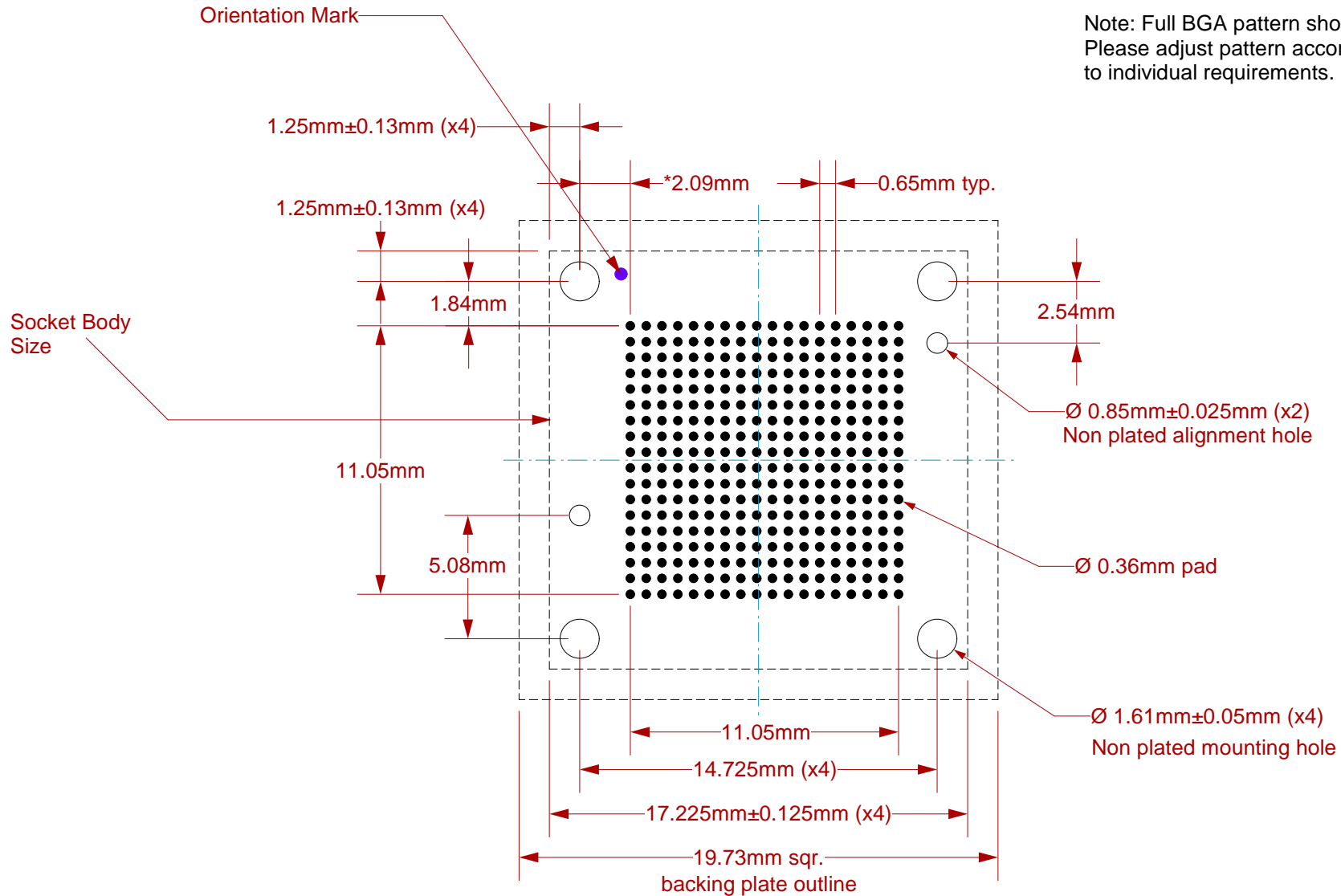

Target PCB Recommendations

Total thickness: 1.6mm min.

Plating: Gold or Solder finish

PCB Pad height: Same or higher than solder mask

All dimensions are in mm unless stated otherwise

Recommended PCB Layout Tolerances: $\pm 0.025\text{mm}$ [± 0.001 "] unless stated otherwise.

	SG-BGA-7034 Drawing		Status: Released	Scale: 4:1	Rev: B
	© 2009 IRONWOOD ELECTRONICS, INC. 11351 Rupp Drive, Suite 400, Burnsville, MN 55337 Tele: (952) 229-8200 www.ironwoodelectronics.com		Drawing: H. Hansen		Date: 1/24/05
			File: SG-BGA-7034 Dwg		Modified: 6/12/09, AE

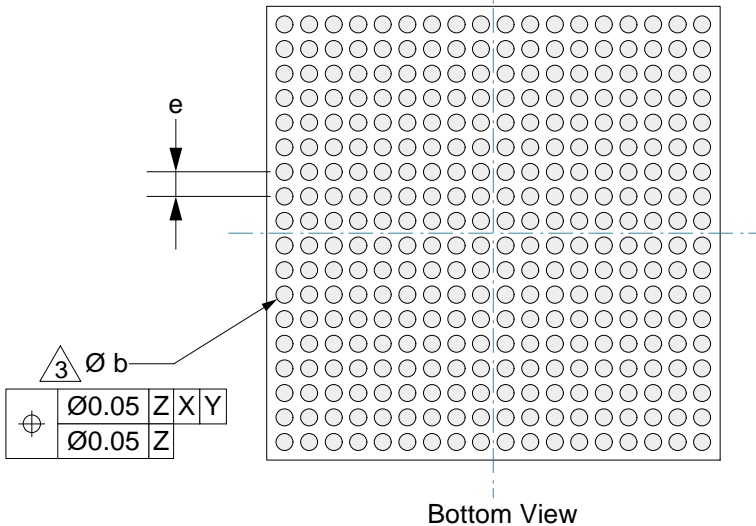
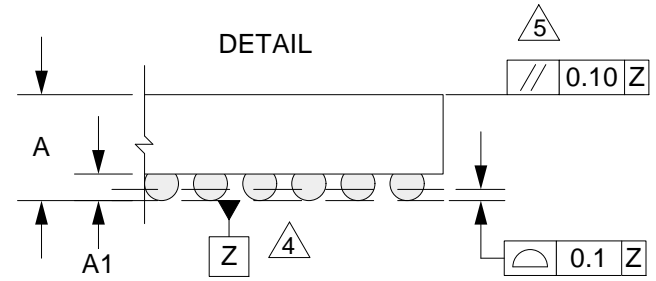
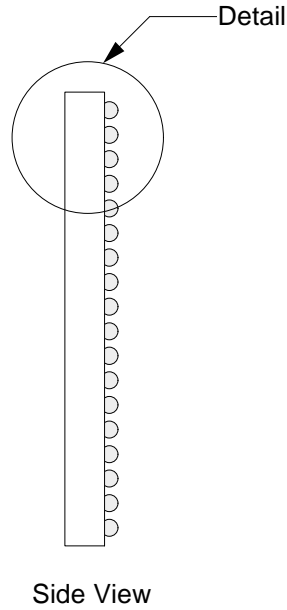
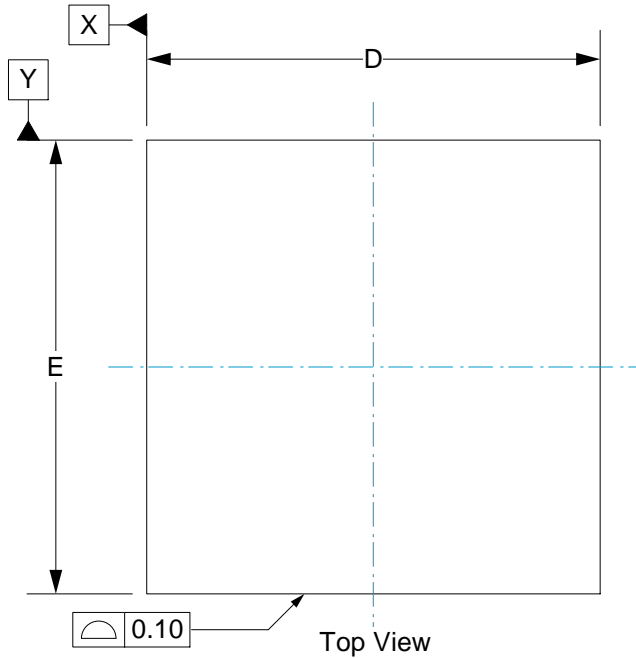

1. Dimensions are in millimeters.
 2. Interpret dimensions and tolerances per ASME Y14.5M-1994.
- 3 Dimension b is measured at the maximum solder ball diameter, parallel to datum plane Z.
 - 4 Datum Z (seating plane) is defined by the spherical crowns of the solder balls.
 - 5 Parallelism measurement shall exclude any effect of mark on top surface of package.

DIM	MIN	MAX
A		1.4
A1	0.25	0.35
b		0.45
D	12.0 BSC	
E	12.0 BSC	
e	0.65 BSC	

18 x 18 array

 <p>© 2009 IRONWOOD ELECTRONICS, INC. 11351 Rupp Drive, Suite 400, Burnsville, MN 55337 Tele: (952) 229-8200 www.ironwoodelectronics.com</p>	<p>SG-BGA-7034 Drawing</p>		<p>Status: Released</p>	<p>Scale: 1:0.2</p>	<p>Rev: B</p>	
	<p>Drawing: H. Hansen</p>			<p>Date: 1/24/05</p>		
	<p>File: SG-BGA-7034 Dwg</p>			<p>Modified: 6/12/09, AE</p>		

Top View

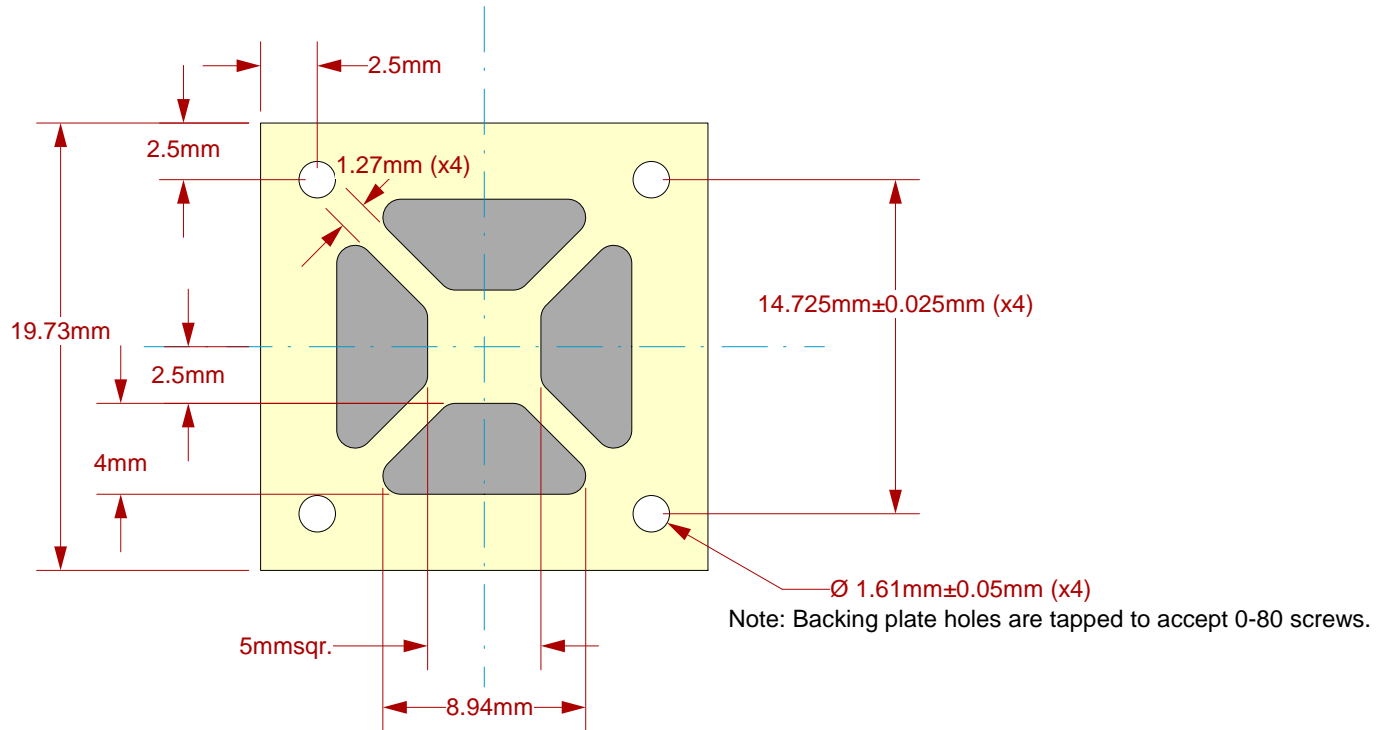

Side View

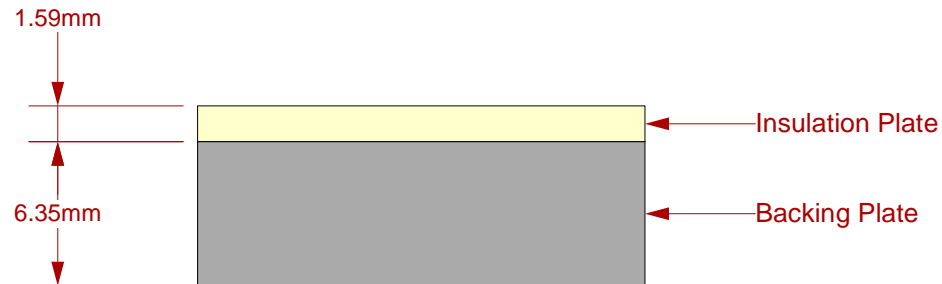

Description: Insulation Plate and Backing Plate

 <p>© 2009 IRONWOOD ELECTRONICS, INC. 11351 Rupp Drive, Suite 400, Burnsville, MN 55337 Tele: (952) 229-8200 www.ironwoodelectronics.com</p>	<p>SG-BGA-7034 Drawing</p>	<p>Status: Released</p>	<p>Scale: 3:1</p>	<p>Rev: B</p>
	<p>Drawing: H. Hansen</p>	<p>Date: 1/24/05</p>		<p>Modified: 6/12/09, AE</p>
<p>File: SG-BGA-7034 Dwg</p>				

All dimensions are in mm.
All tolerances are +/- 0.125mm.
(Unless stated otherwise)