

# DATA SHEET

**TX78/49/13**  
Alloy powder toroids

New data

2008 Sep 01

**RING CORES (TOROIDS)**

**Effective core parameters**

SYMBOL	PARAMETER	VALUE	UNIT	
$\Sigma(l/A)$	core factor (C1)	1.13	mm <sup>-1</sup>	
$V_e$	effective volume	34700	mm <sup>3</sup>	
$l_e$	effective length	200	mm	
$A_e$	effective area	177	mm <sup>2</sup>	
m	mass of core (for $\mu_i$ 125)	MPP	288	g
		Sendust	200 <sup>(1)</sup>	g
		High-Flux	272	g

(1) for material permeability 60

**Coating**

The cores are coated with epoxy. The colour is black (Sendust), grey (MPP) or khaki (High-Flux). Maximum operating temperature is 200 °C.

**Isolation voltage**

AC isolation voltage : 1000 V.  
Contacts are applied on the edge of the ring core, which is also the critical point for the winding operation.

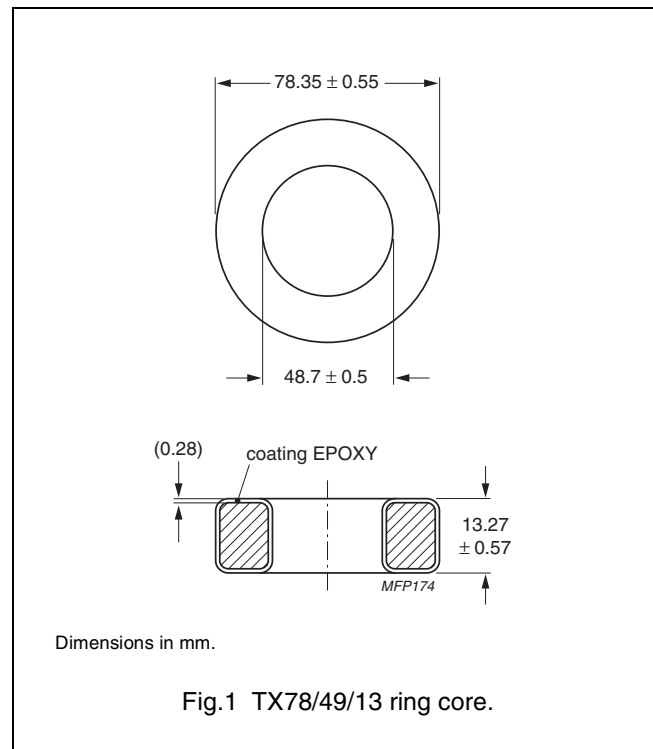

**Ring core data**

GRADE	$A_L$ (nH)	$\mu_i$	B (mT) at	CORE LOSS (W) at	TYPE NUMBER
			H = 100 kA/m; f = 10 kHz; T = 25 °C	f = 100 kHz; B = 100 mT; T = 25 °C	
MPP	16 ± 8 %	14	≥ 640	52.1	TX78/13-M2-A16
	30 ± 8 %	26	≥ 700	41.6	TX78/13-M2-A30
	68 ± 8 %	60	≥ 760	26.0	TX78/13-M2-A68
	142 ± 8 %	125	≥ 800	26.0	TX78/13-M2-A142
	225 ± 8 %	200	≥ 800	52.1	TX78/13-M2-A225
Sendust <sup>(1)</sup>	30 ± 8 %	26	≥ 1000	55.5	TX78/13-S7-A30-MC
	68 ± 8 %	60	≥ 1030	29.7	TX78/13-S7-A68-MC
High-Flux	16 ± 8 %	14	≥ 890	86.8	TX78/13-H2-A16
	30 ± 8 %	26	≥ 980	69.4	TX78/13-H2-A30
	68 ± 8 %	60	≥ 1280	62.5	TX78/13-H2-A68
	142 ± 8 %	125	≥ 1370	69.4	TX78/13-H2-A142

**Note**

1. Mechanical dimensions : OD ≤ 78.9, ID ≥ 48.2, H ≤ 13.84



**DATA SHEET STATUS DEFINITIONS**

DATA SHEET STATUS	PRODUCT STATUS	DEFINITIONS
Preliminary specification	Development	This data sheet contains preliminary data. Ferroxcube reserves the right to make changes at any time without notice in order to improve design and supply the best possible product.
Product specification	Production	This data sheet contains final specifications. Ferroxcube reserves the right to make changes at any time without notice in order to improve design and supply the best possible product.

**DISCLAIMER**

**Life support applications** — These products are not designed for use in life support appliances, devices, or systems where malfunction of these products can reasonably be expected to result in personal injury. Ferroxcube customers using or selling these products for use in such applications do so at their own risk and agree to fully indemnify Ferroxcube for any damages resulting from such application.

**PRODUCT STATUS DEFINITIONS**

STATUS	INDICATION	DEFINITION
<b>Prototype</b>		These are products that have been made as development samples for the purposes of technical evaluation only. The data for these types is provisional and is subject to change.
<b>Design-in</b>		These products are recommended for new designs.
<b>Preferred</b>		These products are recommended for use in current designs and are available via our sales channels.
<b>Support</b>		These products are <b>not</b> recommended for new designs and may not be available through all of our sales channels. Customers are advised to check for availability.