



1.6X LINEAR REGULATOR FOR DC FAN DRIVER CONTROL

FEATURES

- Low Dropout Voltage: 150mV@0.5A
- V_O Follows 1.6 times of V_{SET}
- Enable/Shutdown function
- Stable with Low ESR Ceramic Capacitors
- Current-Limit and Thermal Shutdown Protection
- SOP-8 Pb-Free Package

DESCRIPTION

The APE8873 is a low dropout linear regulator which is designed to power a DC fan and delivers up to 500mA output current. The output voltage follows the 1.6 times of V_{SET} voltage and typical dropout voltage is only 150mV (typical) at 500mA output current. The V_{SET} voltage must be larger than 1V to guarantee V_O 1.6 times of V_{SET} . An enable pin further reduces power dissipation while shut-down. The features of current limit (with fold back current) and over temperature protection protect the device against current over-loads and over temperature. The APE8873 is available in a SOP-8 package.

TYPICAL APPLICATION

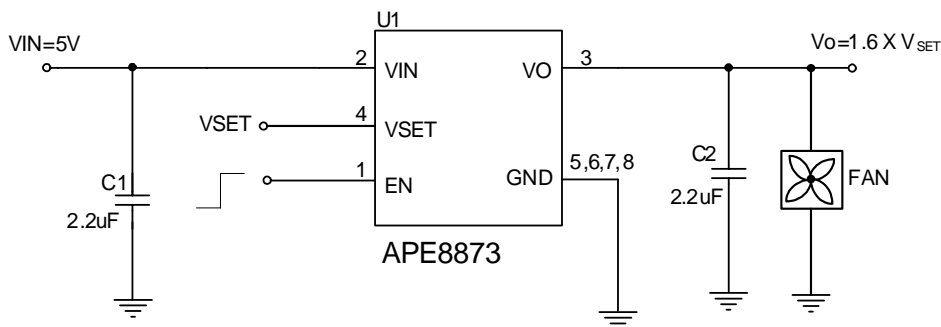

PACKAGE ORDERING INFORMATION

APE8873X
 └───┬───┘
 Package Type
 M : SOP-8L

8873M → Part number
 Y WW SSS → ID code: internal
 └───┬───┘
 WW: 01~52
 └───┬───┘
 Year: 8 : 2008



ABSOLUTE MAXIMUM RATINGS

V_{IN} Supply Voltage (V_{IN})	-0.3 to 7 V
EN Voltage (V_{EN})	-0.3V to V_{IN}
V_{SET} Voltage (V_{SET})	-0.3V to V_{IN}
Power Dissipation (P_D)	Internally limited
Storage Temperature Range (T_{ST})	-65 to +150°C
Junction Temperature Range (T_J)	-40 to 125°C
Operating Temperature Range (T_{OP})	-40 to +85°C
Thermal Resistance from Junction to case (R_{thjc})	20°C/W
Thermal Resistance from Junction to ambient (R_{thja})	60°C/W

Note: R_{thja} is measured with the PCB copper area approximately 1.5 in² (Multi-layer)

PACKAGE INFORMATION

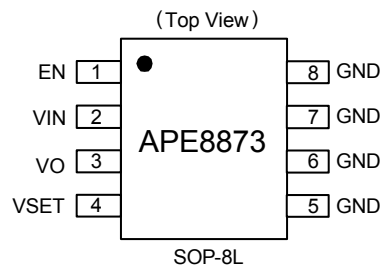

ELECTRICAL SPECIFICATIONS

($V_{SET} = 2V$, $V_{IN} = 5V$, $I_O = 0.5A$, $C_{IN}=C_{OUT}=2.2\mu F$, $T_A=25^\circ C$ unless otherwise specified)

Parameter	SYM	TEST CONDITION	MIN	TYP	MAX	UNITS
V_{IN} Supply Voltage Range	V_{IN}		4.5	-	5.5	V
Quiescent Current	I_{CCQ}	$V_O=5V$, No Load	-	1	-	mA
Standby Current	I_{STB}	$V_{EN}=0V$	-	10	50	uA
Output Voltage/ V_{SET} Voltage	V_O/V_{SET}	$V_{IN}=5.5V$, $V_{SET}=1V\sim 3.2V$	1.552	1.6	1.648	V/V
Line Regulation		$V_{IN}=4.5V$ to 5.5V	-	0.2	0.5	%
Load Regulation		$I_O=10mA \sim 0.5A$	-	0.2	0.5	%
Output Resistance	$R_{DS(ON)}$	$I_O = 0.5A$, $V_{SET}=3.4V$	-	300	400	mΩ
Current Limit	I_{Limt}		-	1	-	A
Short Circuit Current	I_{Short}	$V_O < 0.6V$	-	0.5	-	A
Minimum V_{SET} Voltage	V_{SET}		-	1	-	V
V_{SET} Pin Current	I_{SET}		-	80	200	nA
EN Pin Logic Threshold Voltage	V_{EN-H}	Operating mode	2	-	-	V
	V_{EN-L}	Shutdown mode	-	-	0.8	
EN Pin Pull-Up Current	I_{EN}	$EN=0V$	-	1.5	10	uA
Thermal shutdown Temp	T_{SD}		-	150	-	°C
Thermal Shutdown Hysteresis			-	40	-	°C



PIN DESCRIPTIONS

PIN SYMBOL	PIN DESCRIPTION
GND	GND pin
VIN	IC power supply pin
VO	Output Pin. Its voltage is 1.6 times of V_{SET}
VSET	This pin sets the output voltage. Its voltage must be larger than 1V to guarantee V_O 1.6 times of V_{SET}
EN	This pin is pulling high inside. If EN input < 0.8V, the IC is into shutdown mode.

BLOCK DIAGRAM

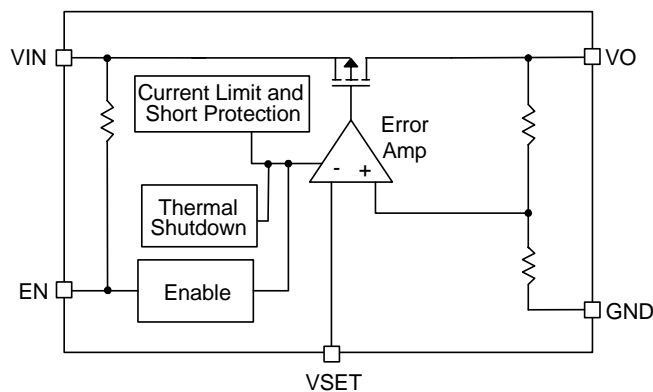

FUNCTION DESCRIPTION

Output Voltage Regulation

The Output Voltage is set by VSET voltage. VO output voltage follows the 1.6 times of VSET voltage until it reaches VIN voltage.

Current-Limit

The APE8873 monitors the current via the output PMOS and limits the maximum current to prevent load and APE8873 from damages during overload or short circuit conditions.

Short Current Protection

When the output voltage drops below 0.6V (typical), which is caused by over load or short circuit, the fold back current limit circuitry limits the output current to 500mA. The fold back current limit is used to reduce the power dissipation during short circuit condition.

Thermal Shutdown

A thermal shutdown circuit limits the junction temperature of APE8873. When the junction temperature exceeds +150°C, a thermal sensor turns off the output PMOS, allowing the device to cool down. The regulator regulates the output again through initiation of a new soft-start cycle after the junction temperature cools by 40°C, resulting in a pulsed output during continuous thermal overload conditions.



APPLICATION INFORMATION

Capacitor Selection

Normally, use a 2.2uF capacitor on the input and a 2.2uF capacitor on the output of the APE8873. In order to insure the circuit stability, the proper output capacitor value should be larger than 1uF. With X5R and X7R dielectrics, 2.2uF is sufficient at all operating temperatures.

Thermal Considerations

The APE8873 series can deliver a current of up to 500mA over the full operating junction temperature range. However, the maximum output current must be derated at higher ambient temperature to ensure the junction temperature does not exceed 125°C. With all possible conditions, the junction temperature must be within the range specified under operating conditions. Power dissipation can be calculated based on the output current and the voltage drop across regulator.

$$P_D = (V_{IN} - V_O) I_O$$

The final operating junction temperature for any set of conditions can be estimated by the following thermal equation:

$$P_{D(MAX)} = (T_{J(MAX)} - T_A) / R_{thja}$$

Where $T_{J(MAX)}$ is the maximum junction temperature of the die (125° C) and T_A is the maximum ambient temperature. The junction to ambient thermal resistance (R_{thja}) for SOP-8L package at recommended minimum footprint is 60°C/W. Visit our website in which “Recommended Footprints for Soldering Surface Mount Packages” for detail.

PCB Layout

1. Please place the input capacitors close to the V_{IN}
2. Ceramic capacitors for load must be placed near the load as close as possible
3. To place APE8873 and output capacitors near the load is good for performance.
4. Large current paths that V_{IN} and Output lines must have wide tracks.
5. GND connect large copper area can reduced IC temperature.



Package Outline : SO-8

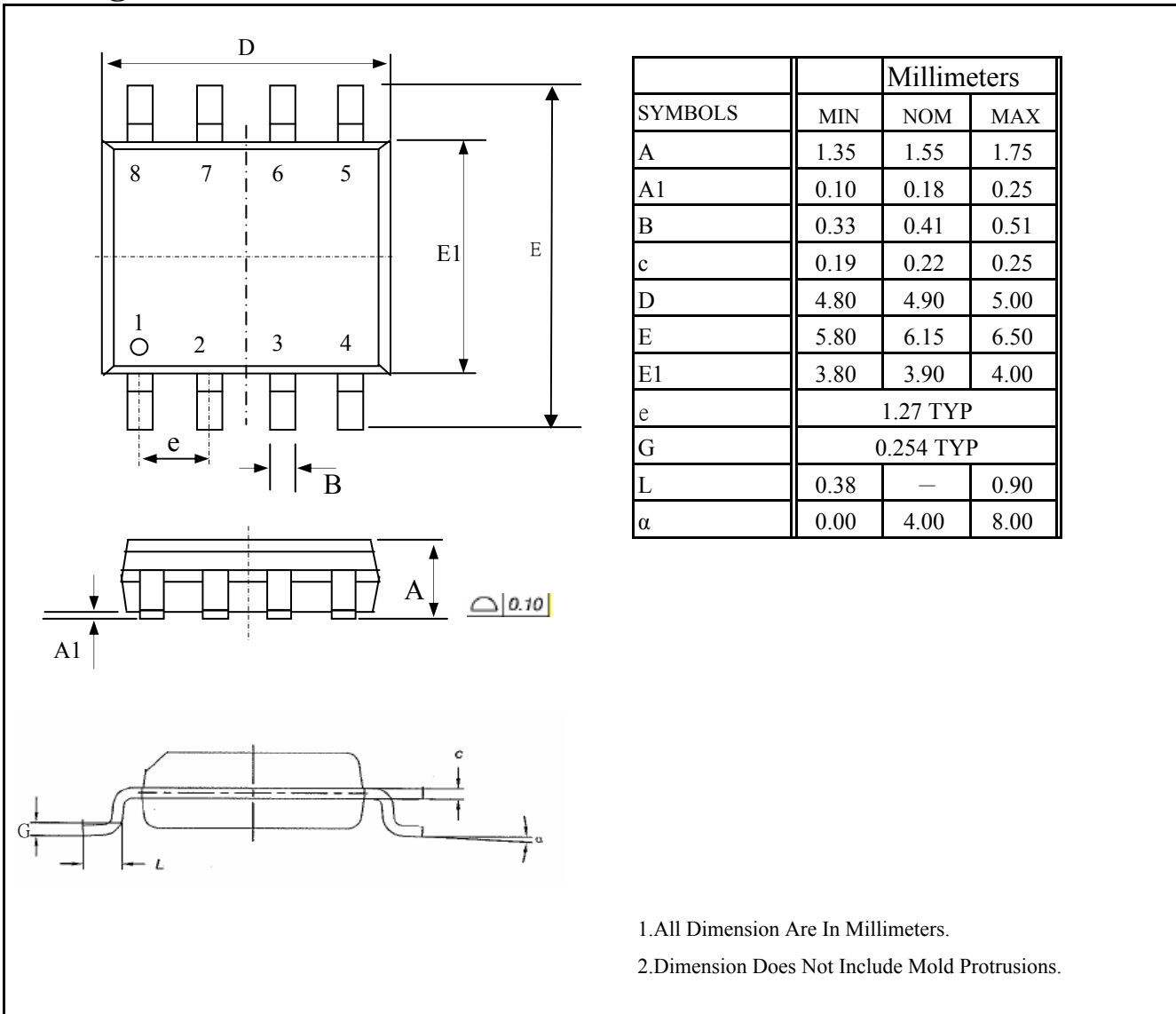

Part Marking Information & Packing : SO-8

