

Space-saving Plug-in Signal Conditioners H-UNIT

CT TRANSMITTER

(RMS sensing)

Functions & Features

- Converting an alternating current from a current transformer into a standard process signal
- Minimum ripple
- RMS sensing
- CT Protector provided for open-circuit protection
- Highdensity mounting

Typical Applications

- Centralized monitoring and control of motors, pumps or heaters by DCS
- Monitoring power line and power supply current

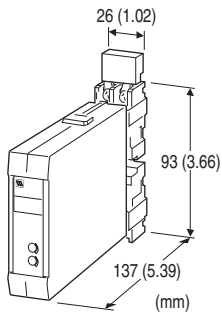

MODEL: HCE-[1][2]-R[3]

ORDERING INFORMATION

• Code number: HCE-[1][2]-R[3]

Specify a code from below for each of [1] through [3].

- (e.g. HCE-1A-R/Q)
- Special output range (For codes Z & 0)
- Specify the specification for option code /Q (e.g. /C01/S01)

[1] INPUT

Current

- 1: 0 - 1 A AC
- 5: 0 - 5 A AC

[2] OUTPUT

Current

- A: 4 - 20 mA DC (Load resistance 750 Ω max.)
- B: 2 - 10 mA DC (Load resistance 1500 Ω max.)
- C: 1 - 5 mA DC (Load resistance 3000 Ω max.)

- D: 0 - 20 mA DC (Load resistance 750 Ω max.)
- E: 0 - 16 mA DC (Load resistance 900 Ω max.)
- F: 0 - 10 mA DC (Load resistance 1500 Ω max.)
- G: 0 - 1 mA DC (Load resistance 15 k Ω max.)
- Z: Specify current (See OUTPUT SPECIFICATIONS)

Voltage

- 1: 0 - 10 mV DC (Load resistance 10 k Ω min.)
- 2: 0 - 100 mV DC (Load resistance 100 k Ω min.)
- 3: 0 - 1 V DC (Load resistance 1000 Ω min.)
- 4: 0 - 10 V DC (Load resistance 10 k Ω min.)
- 5: 0 - 5 V DC (Load resistance 5000 Ω min.)
- 6: 1 - 5 V DC (Load resistance 5000 Ω min.)
- 0: Specify voltage (See OUTPUT SPECIFICATIONS)

POWER INPUT

DC Power

R: 24 V DC

(Operational voltage range 24 V \pm 10 %, ripple 10 %p-p max.)

[3] OPTIONS

blank: none

/Q: With options (specify the specification)

SPECIFICATIONS OF OPTION: Q (multiple selections)

COATING (For the detail, refer to M-System's web site.)

- /C01: Silicone coating
- /C02: Polyurethane coating
- /C03: Rubber coating

TERMINAL SCREW MATERIAL

/S01: Stainless steel

GENERAL SPECIFICATIONS

Construction: Plug-in

Connection: M3.5 screw terminals (torque 0.8 N·m)

Screw terminal: Nickel-plated steel (standard) or stainless steel

Housing material: Flame-resistant resin (black)

Isolation: Input to output to power

Input waveform: Up to 15 % of 3rd harmonic content

Overrange output: 0 to 120 % at 1 - 5 V

Zero adjustment: -5 to +5 % (front)

Span adjustment: 95 to 105 % (front)

INPUT SPECIFICATIONS

Frequency: 50 or 60 Hz

Input burden: 0.5 VA max.

Overload capacity: 500 % of rating for 5 sec., 120 % continuous

Operational range: 0 - 120 % of rating

OUTPUT SPECIFICATIONS

- **DC Current:** 0 - 20 mA DC
- Minimum span:** 1 mA
- Offset:** Max. 1.5 times span
- Load resistance:** Output drive 15 V max.
- **DC Voltage:** 0 - 12 V DC
- Minimum span:** 5 mV
- Offset:** Max. 1.5 times span
- Load resistance:** Output drive 1 mA max.; at ≥ 0.5 V

INSTALLATION

- Current consumption:** Approx. 55 mA
- Operating temperature:** -5 to +55°C (23 to 131°F)
- Operating humidity:** 30 to 90 %RH (non-condensing)
- Mounting:** Surface or DIN rail; Standard Rack Mounting
- Frame BX-16H available
- Weight:** 200 g (0.44 lb)

PERFORMANCE in percentage of span

- Accuracy:** ± 0.3 %
- Temp. coefficient:** ± 0.015 %/°C (± 0.008 %/°F)
- Response time:** ≤ 0.5 sec. (0 - 90 %)
- Ripple:** 0.5 %p-p max. (100/120 Hz)
- Line voltage effect:** ± 0.1 % over voltage range
- Insulation resistance:** ≥ 100 M Ω with 500 V DC
- Dielectric strength:** 2000 V AC @ 1 minute
(input to output or power)
- 500 V AC @ 1 minute (output to power)
- 1500 V AC @ 1 minute
(input or output or power to ground)

EXTERNAL DIMENSIONS unit: mm (inch)

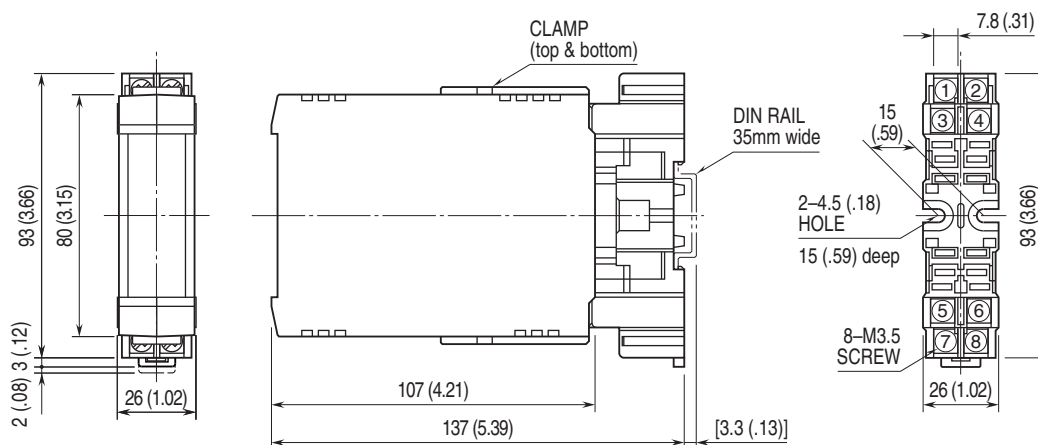

•When mounting, no extra space is needed between units.

TERMINAL ASSIGNMENTS unit: mm (inch)

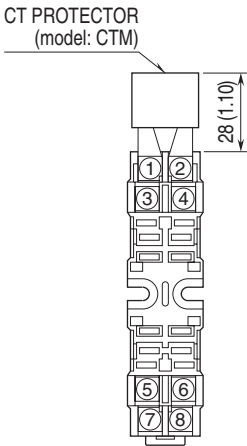

SCHEMATIC CIRCUITRY & CONNECTION DIAGRAM

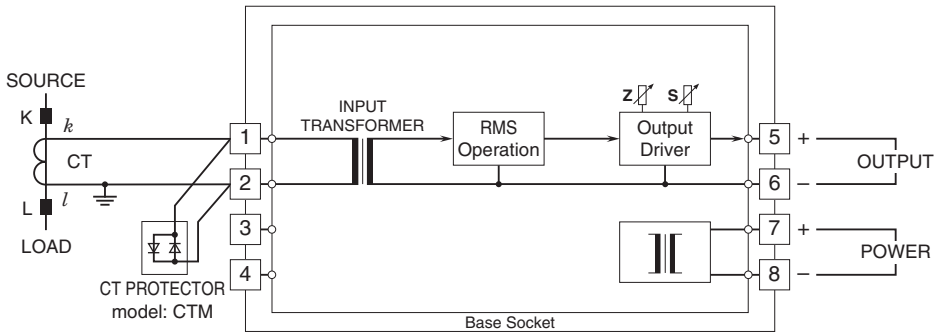

Specifications are subject to change without notice.