

LOC		DIST		REVISIONS			
DF	DO	REV	DATE	DESCRIPTION	DATE	BY	APPV
		R	16MAR12	REVISED PER ECO-12-004104		PY	RL

- THIS RECEPTACLE WILL MATE WITH ANY 36C4, SIZE 5 PLUG IN AMPLIMITE SERIES.
- MAXIMUM WIRE INSULATION TO BE USED WITH THIS RECEPTACLE IS $\phi.072$.
- THIS CONNECTOR ACCEPTS (4) POWER 8, OR COAX SOCKET CONTACTS IN POSITIONS A1 THRU A4, PURCHASED SEPARATELY.
- THIS CONNECTOR ACCEPTS SIZE 20 SOCKET CONTACTS IN POSITIONS 1 THRU 32, PURCHASED SEPARATELY.

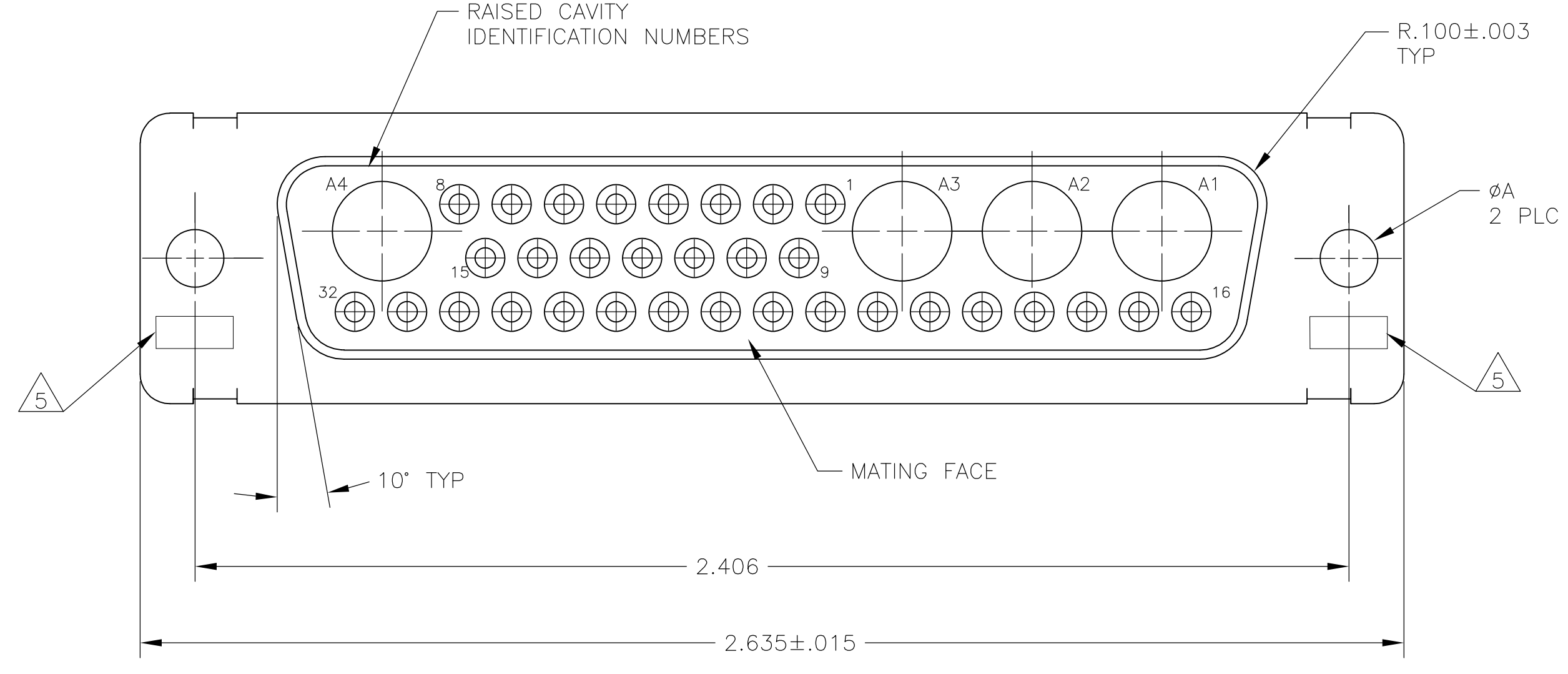

- 5 UL/CSA DESIGNATION STAMPED IN THIS AREA, OPTIONAL.
- 6 MATERIAL: STEEL PER ASTM-A-109.
- 7 MATERIAL: BRASS PER MIL-C-50 AND ASTM-B-36 UNS NO. C26000.
- 8 FINISH: CADMIUM PLATED PER QQ-P-416, TYPE II, CLASS 2.
- 9 FINISH: GOLD PER MIL-G-45204 TYPE II, GRADE C, CLASS 1 OVER COPPER PER MIL-C-14550, CLASS IV.
- 10 FINISH: TIN PER ASTM-B-545 .000200 MIN THK OVER COPPER PER AMS2418 .000100-.000200 THK.
- 11 FINISH: ZINC PLATE PER ASTM-B-633 .000200-.000400 THK WITH SUPPLEMENTARY CHROMATE (Cr3+).

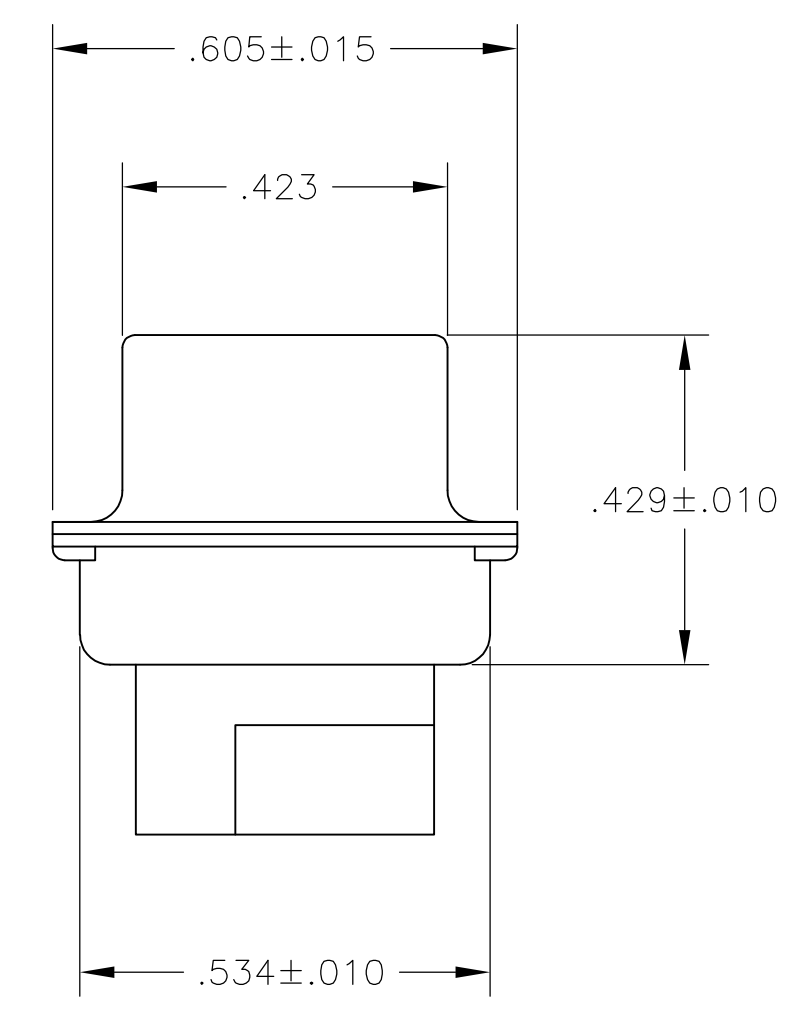
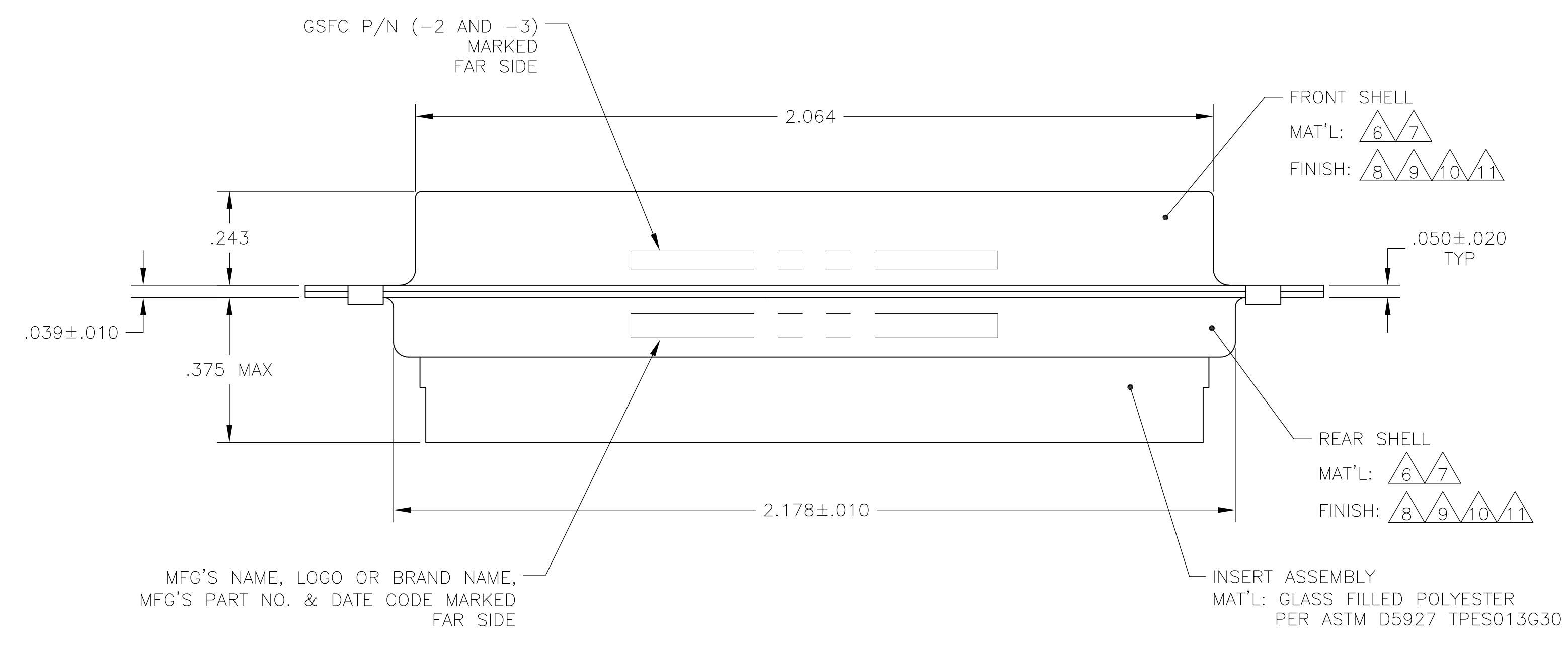

REMARKS	øA	GSFC P/N	PART NO.
6 10	.120	-	5-208550-4
6 11	.120	-	5-208550-1
6 10	.120	-	208550-4
7 9	.154	311P405-23S-B-15	208550-3
7 9	.120	311P405-23S-B-12	208550-2
6 8	.120	-	208550-1

THIS DRAWING IS A CONTROLLED DOCUMENT.

APPROVED: T. SHUEY 07-JAN-88
 CHK: A. EMADI 27-JAN-88
 NAME: A. EMADI 27-JAN-88

STE TE Connectivity

RECEPTACLE ASSEMBLY
 AMPLIMITE 36C4
 SIZE 5, COAX MIX

DIMENSIONS: INCHES
 TOLERANCES UNLESS OTHERWISE SPECIFIED:
 0 PLC ± -
 1 PLC ± -
 2 PLC ± -
 3 PLC ± .005(0.13)
 4 PLC ± -
 ANGLES ± 0° 30'

MATERIAL: - FINISH: -

SIZE: A1 00779 C=208550
 WEIGHT: -
 CUSTOMER DRAWING

SCALE: 4:1 SHEET: 1 OF 1 REV: R