



U74HC148

CMOS IC

8-LINE TO 3-LINE PRIORITY ENCODERS

DESCRIPTION

The UTC **U74HC148** devices encode eight data lines to 3-line binary (octal). It feature priority decoding of the inputs to ensure that only the highest-order data line is encoded. (enable input EI and enable output EO) have been provided to allow octal expansion without the need for external circuitry. Data inputs and outputs are active at the low logic level.

FEATURES

- * Wide supply voltage range from 2.0V to 6.0V
- * Low static power consumption; $I_{CC}=8\mu A$ (Max.)
- * Encode Eight Data Lines to 3-Line Binary (Octal)
- * High Noise Immunity

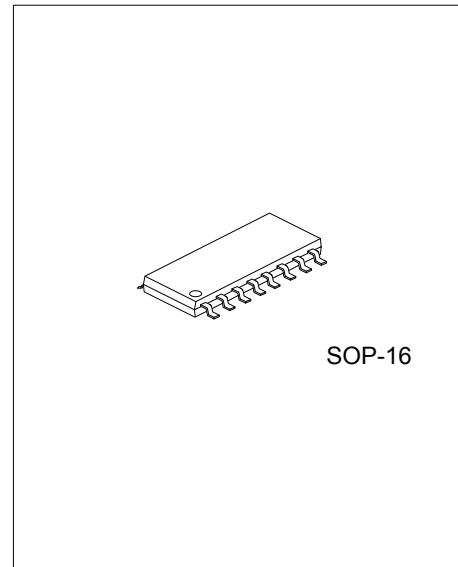

ORDERING INFORMATION

Ordering Number	Package	Packing
U74HC148G-P16-R	TSSOP-16	Tape Reel

<p>U74HC148G-P16-R</p> <ul style="list-style-type: none"> (1) Packing Type (2) Package Type (3) Green Package 	<ul style="list-style-type: none"> (1) R: Tape Reel (2) P16: TSSOP-16 (3) G: Halogen Free and Lead Free
--	--

MARKING

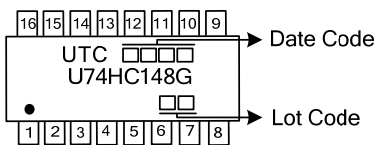

■ PIN CONFIGURATION

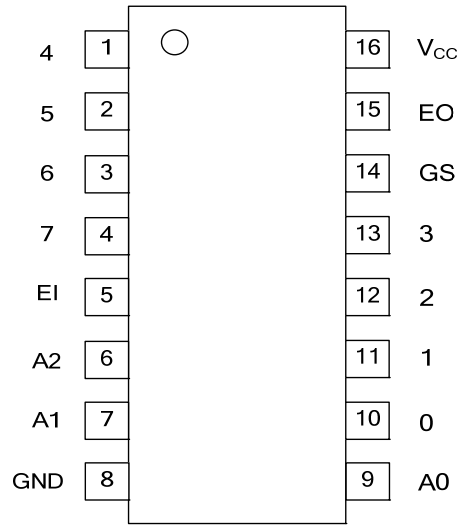

■ FUNCTION TABLE

INPUTS									OUTPUTS				
EI	0	1	2	3	4	5	6	7	A2	A1	A0	GS	EO
H	X	X	X	X	X	X	X	X	H	H	H	H	H
L	H	H	H	H	H	H	H	H	H	H	H	H	L
L	X	X	X	X	X	X	X	L	L	L	L	L	H
L	X	X	X	X	X	X	L	H	L	L	H	L	H
L	X	X	X	X	X	L	H	H	L	H	L	L	H
L	X	X	X	L	H	H	H	H	H	L	L	L	H
L	X	X	L	H	H	H	H	H	H	L	H	L	H
L	X	L	H	H	H	H	H	H	H	H	L	L	H
L	L	H	H	H	H	H	H	H	H	H	H	L	H

Note: H: High voltage level; L: Low voltage level; X: Don't care

■ LOGIC DIAGRAM (positive logic)

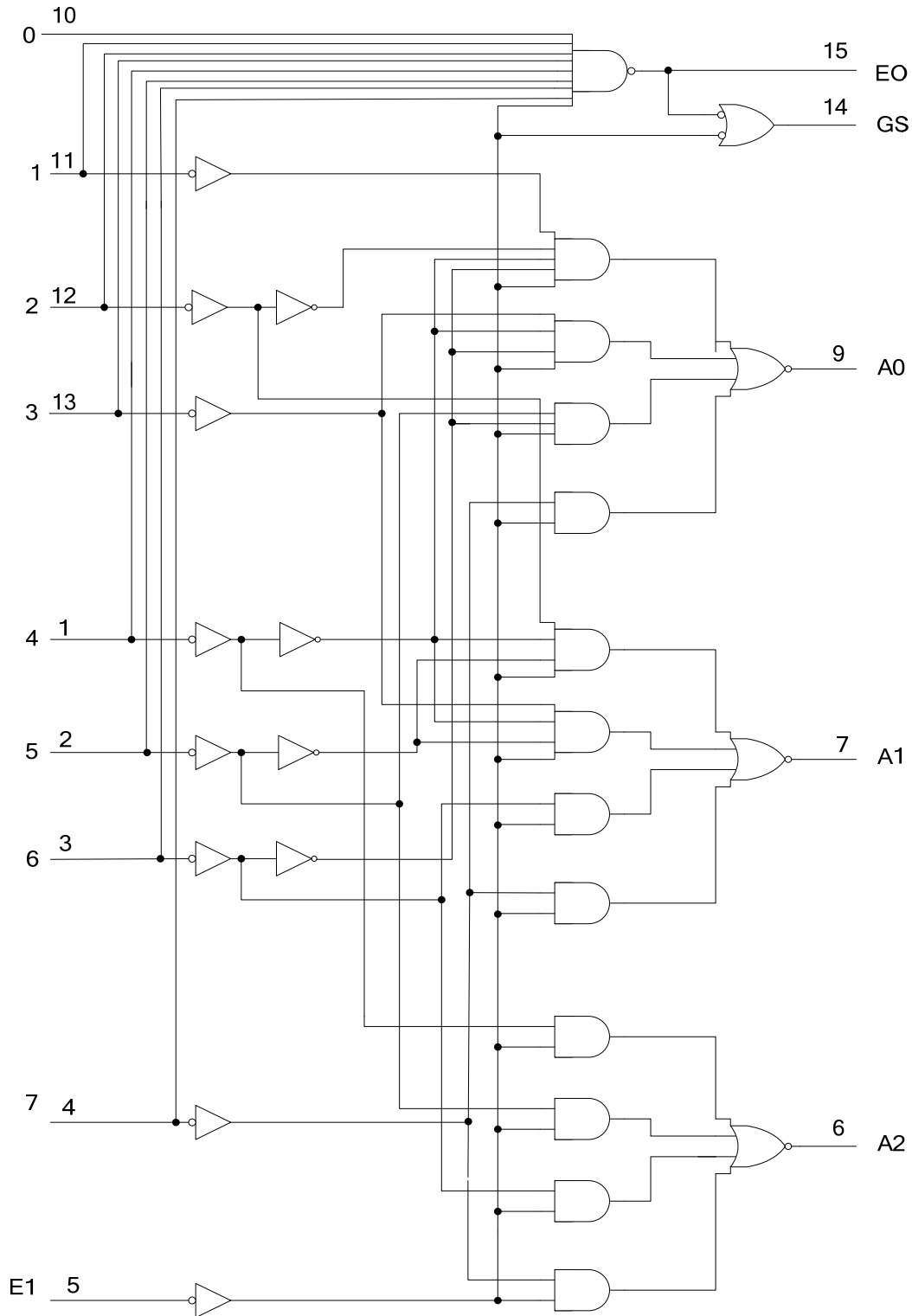

■ ABSOLUTE MAXIMUM RATING

PARAMETER	SYMBOL	CONDITIONS	RATINGS	UNIT
Supply Voltage	V_{CC}		-0.5 ~ +7.0	V
Input Voltage	V_{IN}		-0.5 ~ $V_{CC}+0.5$	V
Output Voltage	V_{OUT}	Active Mode	-0.5 ~ $V_{CC}+0.5$	V
Continuous V_{CC} or GND Current	I_{CC}		±50	mA
Continuous Output Current	I_{OUT}	$V_{OUT}=0V \sim V_{CC}$	±25	mA
Input Clamp Current (Note 2)	I_{IK}	$V_{IN}<0V$ or $V_{IN}>V_{CC}$	±20	mA
Output Clamp Current (Note 2)	I_{OK}	$V_{OUT}>V_{CC}$ or $V_{OUT}<0V$	±20	mA
Storage Temperature Range	T_{STG}		-65 ~ +150	°C

Notes: 1. Absolute maximum ratings are those values beyond which the device could be permanently damaged.

Absolute maximum ratings are stress ratings only and functional device operation is not implied.

2. The input and output voltage ratings may be exceeded if the input and output current ratings are observed.

■ RECOMMENDED OPERATING CONDITIONS

PARAMETER	SYMBOL	TEST CONDITIONS	MIN	TYP	MAX	UNIT
Supply Voltage	V_{CC}		2.0	5.0	6.0	V
Input Voltage	V_{IN}		0		V_{CC}	V
Output Voltage	V_{OUT}		0		V_{CC}	V
Operating Temperature	T_A		-40		85	°C
Input Transition Rise or Fall Rate	$\Delta t/\Delta v$	$V_{CC}=2.0V$			1000	ns
		$V_{CC}=4.5V$			500	ns
		$V_{CC}=6.0V$			400	ns

■ ELECTRICAL CHARACTERISTICS ($T_A = 25^\circ C$, unless otherwise specified)

PARAMETER	SYMBOL	TEST CONDITIONS	MIN	TYP	MAX	UNIT		
High-level Input Voltage	V_{IH}	$V_{CC}=2.0V$	1.5			V		
		$V_{CC}=4.5V$	3.15			V		
		$V_{CC}=6.0V$	4.2			V		
Low-level Input Voltage	V_{IL}	$V_{CC}=2.0V$			0.5	V		
		$V_{CC}=4.5V$			1.35	V		
		$V_{CC}=6.0V$			1.8	V		
High-Level Output Voltage	V_{OH}	$V_{CC}=2.0V$	1.9	1.998		V		
		$V_{CC}=4.5V$			4.4	4.498	V	
		$V_{CC}=6.0V$			5.9	5.998	V	
		$V_{CC}=4.5V, V_{IN}=V_{IH}$ or $V_{IL}, I_{OH}=-4mA$	3.98			V		
		$V_{CC}=6.0V, V_{IN}=V_{IH}$ or $V_{IL}, I_{OH}=-5.2mA$	5.48			V		
Low-Level Output Voltage	V_{OL}	$V_{CC}=2.0V$		0.002	0.1	V		
		$V_{CC}=4.5V$				0.001	0.1	V
		$V_{CC}=6.0V$				0.001	0.1	V
		$V_{CC}=4.5V, V_{IN}=V_{IH}$ or $V_{IL}, I_{OH}=4mA$			0.26	V		
		$V_{CC}=6.0V, V_{IN}=V_{IH}$ or $V_{IL}, I_{OH}=5.2mA$			0.26	V		
Input Leakage Current	$I_{I(LEAK)}$	$V_{CC}=6.0V, V_{IN}=V_{CC}$ or GND			±0.1	µA		
Quiescent Supply Current	I_{CC}	$V_{CC}=6.0V, V_{IN}=V_{CC}$ or GND, $I_{OUT}=0A$			8	µA		
Input Capacitance	C_I	$V_{CC}=2.0\sim 6.0V, V_{IN}=V_{CC}$ or GND		3	10	pF		

■ SWITCHING CHARACTERISTICS ($C_L=50\text{pF}$, $T_A=25^\circ\text{C}$, unless otherwise specified)

PARAMETER	SYMBOL	TEST CONDITIONS	MIN	TYP	MAX	UNIT
Propagation delay from input (1-7) to output(A0~A2)	t_{PD}	$V_{CC}=2.0\text{V}$		69	180	ns
		$V_{CC}=4.5\text{V}$		23	36	ns
		$V_{CC}=6.0\text{V}$		21	31	ns
Propagation delay from input (0-7) to output(E0)		$V_{CC}=2.0\text{V}$		60	150	ns
		$V_{CC}=4.5\text{V}$		20	30	ns
		$V_{CC}=6.0\text{V}$		17	26	ns
Propagation delay from input (0-7) to output(GS)		$V_{CC}=2.0\text{V}$		75	190	ns
		$V_{CC}=4.5\text{V}$		25	38	ns
		$V_{CC}=6.0\text{V}$		21	32	ns
Propagation delay from input (E1) to output(A0~A2)		$V_{CC}=2.0\text{V}$		78	195	ns
		$V_{CC}=4.5\text{V}$		26	39	ns
		$V_{CC}=6.0\text{V}$		22	33	ns
Propagation delay from input (E1) to output(GS)	$V_{CC}=2.0\text{V}$		57	145	ns	
	$V_{CC}=4.5\text{V}$		19	29	ns	
	$V_{CC}=6.0\text{V}$		16	25	ns	
Propagation delay from input (E1) to output(E0)	$V_{CC}=2.0\text{V}$		66	166	ns	
	$V_{CC}=4.5\text{V}$		22	33	ns	
	$V_{CC}=6.0\text{V}$		19	28	ns	
Propagation delay to output(Any)	t_t	$V_{CC}=2.0\text{V}$		28	75	ns
	$V_{CC}=4.5\text{V}$			8	15	ns
	$V_{CC}=6.0\text{V}$			6	13	ns

■ OPERATING CHARACTERISTICS ($T_A=25^\circ\text{C}$, unless otherwise specified)

PARAMETER	SYMBOL	TEST CONDITIONS	MIN	TYP	MAX	UNIT
Power Dissipation Capacitance	C_{PD}	No load.		35		pF

■ TEST CIRCUIT AND WAVEFORMS

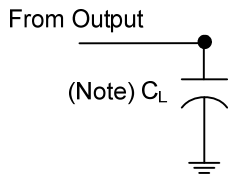

TEST CIRCUIT

Note: C_L includes probe and jig capacitance. $C_L=50\text{pF}$

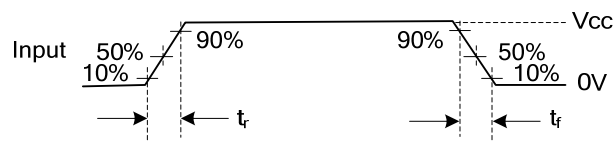

Fig. 1 Input Rise and Fall Times

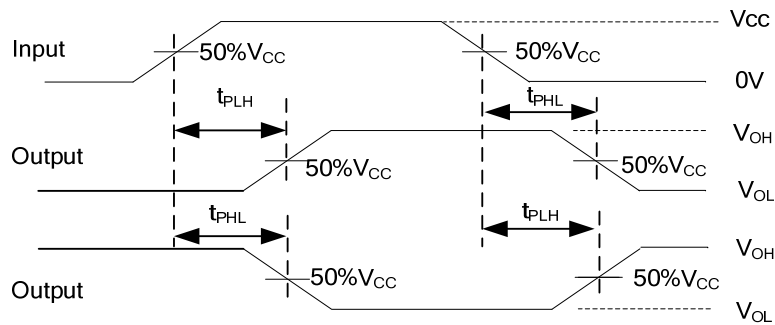

Fig. 2 Load circuitry for switching times.

Notes: 1. C_L includes probe and jig capacitance.

2. All input pulses are supplied by generators having the following characteristics: $\text{PRR} \leq 10\text{MHz}$, $Z_o = 50\Omega$.

UTC assumes no responsibility for equipment failures that result from using products at values that exceed, even momentarily, rated values (such as maximum ratings, operating condition ranges, or other parameters) listed in products specifications of any and all UTC products described or contained herein. UTC products are not designed for use in life support appliances, devices or systems where malfunction of these products can be reasonably expected to result in personal injury. Reproduction in whole or in part is prohibited without the prior written consent of the copyright owner. The information presented in this document does not form part of any quotation or contract, is believed to be accurate and reliable and may be changed without notice.