

Visit nipponpulse.com to download 3D CAD drawings and 2D prints of this motor.

	S080D		S080T		S080Q		
Electrical Specs	S080D	S080D 1S	S080T	S080T 1S	S080Q	S080Q 2S	S080Q 1S
Continuous Force ¹	1.8N (0.4lbs)		2.7N (0.61lbs)		3.5N (0.79lbs)		
Continuous Current ¹	0.84Arms	1.7Arms	0.84Arms	2.5Arms	0.84Arms	1.7Arms	3.4Arms
Acceleration Force ²	7.2N (1.6lbs)		11N (2.4lbs)		14N (3.1lbs)		
Acceleration Current ²	3.4Arms	6.7Arms	3.4Arms	10Arms	3.4Arms	6.7Arms	13Arms
Force Constant (K _f)	2.1N/Arms (0.48lbs/amp)	1.1N/Arms (0.25lbs/amp)	3.2N/Arms (0.72lbs/amp)	1.1N/Arms (0.25lbs/amp)	4.2N/Arms (0.94lbs/amp)	2.1N/Arms (0.47lbs/amp)	1.0N/Arms (0.22lbs/amp)
Back EMF (K _e)	0.71V/m/s (0.02V/in/s)	0.36V/m/s (0.01V/in/s)	1.1V/m/s (0.03V/in/s)	0.36V/m/s (0.01V/in/s)	1.4V/m/s (0.04V/in/s)	0.70V/m/s (0.02V/in/s)	0.35V/m/s (0.01V/in/s)
Resistance 25°C, ³	4.7Ω	1.2Ω	6.8Ω	0.76Ω	9.0Ω	2.3Ω	0.56Ω
Inductance ³	0.7mH	0.18mH	1.0mH	0.11mH	1.3mH	0.33mH	0.081mH
Electric Time Constant	0.149ms		0.147ms		0.144ms		
Max. Rated Voltage (AC)	240V						
Fundamental Motor Constant (K _m)	0.98N√W		1.23N√W		1.39N√W		
Magnetic Pitch (North-North)	30mm (1.18in)						

Is this the proper Linear Shaft Motor for your application? Use our [SMART sizing program](#) to assist in your decision.

This motor can be customized to fit your application demands; contact your application engineer for more information.

¹ Based on a temp rise of coil surface of 110°K over 25°C ambient temperature stalled forcer, and no external cooling or heat sinking.

² Can be maintained for a maximum of 40 seconds. Higher forces and current possible for short periods of time, consult Nippon Pulse for more information.

³ All winding parameters listed are measured line-to-line (phase-to-phase).

Thermal Specs	S080D	S080T	S080Q
Max Phase Temperature ⁴	135°C (275°F)		
Thermal Resistance (Coil) (K _q)	33.2°C/W	22.9°C/W	17.3°C/W

⁴ The standard temperature difference between the coil and the forcer surface is 10°C.

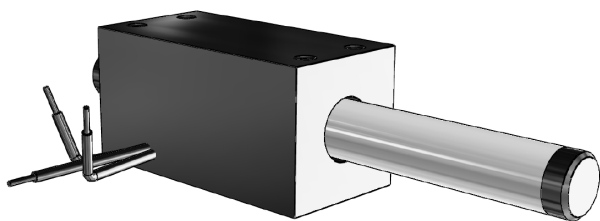

Bus Voltage

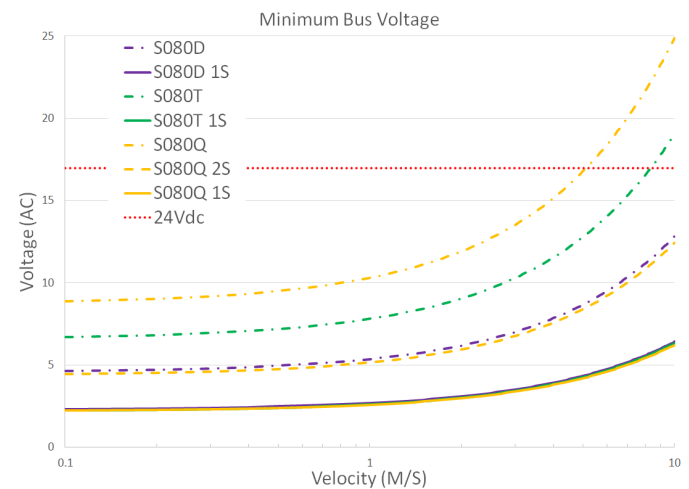

Part Numbering System

S	—	Shaft Size 080	—	Forcer Size (A) <u>X</u>	—	Parallel Option <u>XX</u>	—	Usable Stroke (S) <u>XXXst</u>	—	Options <u>XX</u>	—	Options <u>XX</u>
				D: Double (2) windings T: Triple (3) windings Q: Quadruple (4) windings		Blank: Single Motor PL: Parallel Motors		25-300mm		Blank: Standard WP: Water Resistant HA: Digital Hall Effect CE: CE type motor FG: Frame Ground		Blank: Standard FO: Forcer Only SO: Shaft Only

Forcer Specs	S080D	S080T	S080Q
Forcer Length (A)	40mm (1.57in)	55mm (2.17in)	70mm (2.76in)
Forcer Width	20mm (0.79in)		
Forcer Screw Pitch (P)	34mm (1.34in)	49mm (1.93in)	64mm (2.52in)
Forcer Weight	0.05kg (0.11lbs)	0.06kg (0.13lbs)	0.08kg (0.18lbs)
Gap	0.50mm (0.02lbs)		
Screw	M3		
Tightening torque	0.63 Nm		

Tolerances are as follows:

Dimension (mm)	Tolerance (mm)
0 - 6	±0.1
7 - 30	±0.2
31 - 120	±0.3
121 - 315	±0.5
316 - 1000	±0.8
1001 - 2000	±1.2
2000 -	±1.5

L = See Shaft Length
L1 = Usable Stroke + A
L2 = See Support Length
A = See Forcer Length
P = See Forcer Screw Pitch

Unless otherwise specified, dimensions are in mm

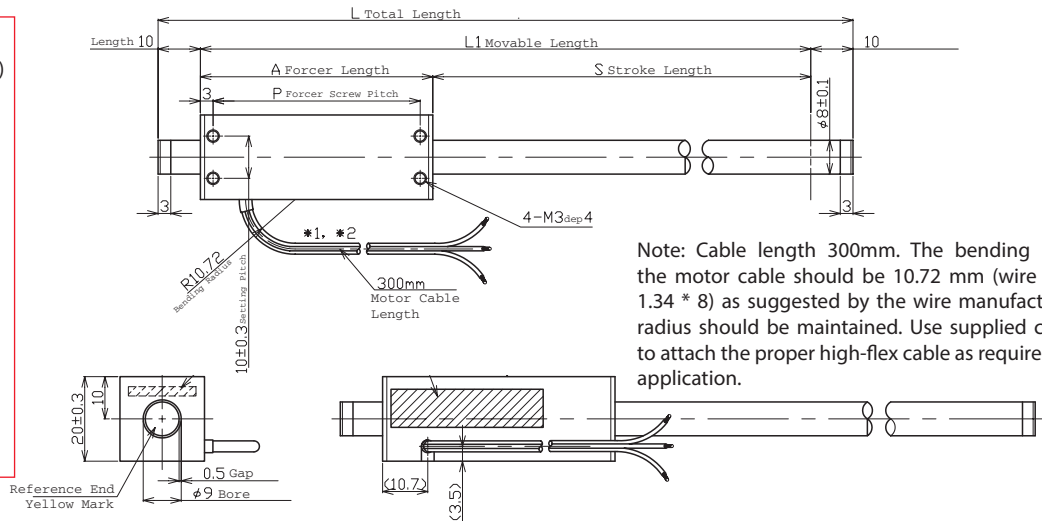

Note: Cable length 300mm. The bending radius of the motor cable should be 10.72 mm (wire diameter 1.34 * 8) as suggested by the wire manufacturer. This radius should be maintained. Use supplied connector to attach the proper high-flex cable as required by your application.

Hall Effect Specs

Forcer Length (A)

Forcer Screw Pitch (P) 0.39

Forcer Screw Pitch 10

1.10

28

0.79

20

Sensor Cable Specs

Wire Type	UL 758
Wire AWG	28
VCC	Red
GND	Black
Sensor 1	White
Sensor 2	Blue
Sensor 3	Yellow
No Connection	No wire

The bending radius of the sensor cable should be R10.72 mm (wire diameter 1.38 * 8) as suggested by the wire manufacturer. This radius should be maintained.

FG/FGA Type Motor Cable

Technical drawing showing the FG/FGA Type Motor Cable with dimensions: 20±0.3mm for the main body, 10mm for the mounting surface, and a 0.5mm gap. It includes a serial number, rating plate, and mounting surface. The cable is connected to a frame ground, with a signage of frame ground.

Wire Type	UL 1330
Wire AWG	20
Frame Ground	Green/Yellow

Shaft Length (L)

Stroke	S080D	S080T	S080Q
25	85mm (3.3in)	100mm (3.9in)	115mm (4.5in)
50	110mm (4.3in)	125mm (4.9in)	140mm (5.5in)
100	160mm (6.3in)	175mm (6.9in)	190mm (7.5in)
150	210mm (8.3in)	225mm (8.9in)	240mm (9.4in)
200	260mm (10.2in)	275mm (10.8in)	290mm (11.4in)

Shaft Diameter (D) - 8mm ±0.1

Total Length (L)=Stroke (S)+Forcer Length (A)+(Support Length (L2)x2)

Additional stroke lengths are available (up to 230mm for S080D and up to 215mm for S080T). Contact Nippon Pulse for more information.

Shaft Mass

Stroke	S080D	S080T	S080Q
25	0.02kg (0.05lb)	0.03kg (0.06lb)	0.03kg (0.07lb)
50	0.03kg (0.07lb)	0.04kg (0.08lb)	0.04kg (0.09lb)
100	0.05kg (0.11lb)	0.05kg (0.12lb)	0.06kg (0.13lb)
150	0.07kg (0.15lb)	0.07kg (0.16lb)	0.08kg (0.17lb)
200	0.08kg (0.19lb)	0.09kg (0.2lb)	0.1kg (0.21lb)

Forcer Spacing Distance

Spec	S080T	S080Q
Forcer Spacing Distance	5mm	
Pole (N/S) Distance	15mm	
Forcer Length	55mm	70mm
Flip Forcers	No	Yes

Tandem S080D forcers are possible, but are equivalent to one (1) S080Q forcer and thus are not listed above.

Tandem Forcer



Forcer Spacing Distance

Support and Bending

Stroke	Support Length (L2)	Max. Bending
All	10mm	0.05mm

Connector (Motor Cable)

Receptacle Housing	XMR-03V
Plug Housing	XMP-03V
Retainer	XMS-03V
Pin Contact	SXM-001T-P0.6
Socket Contact	SXA-001T-P0.6

To be installed by the user.

Standard Lead Wire

Wire Type	UL 1430
Wire AWG	28
U Phase	Red
V Phase	White
W Phase	Black

300mm lead wire bare leads. The bending radius of the motor cable should be 10.72 mm as suggested by the wire manufacturer.

FGA/CE Type Lead Wire

Ground Wire	CE
Wire Type	UL 1330
Wire AWG	24
U Phase	Red
V Phase	White
W Phase	Black

300mm lead wire bare leads. The bending radius of the motor cable should be 16.96mm as suggested by the wire manufacturer. FG type with insulating sheet between coils and case. Meets all requirements of EN60034-1 (1998).

Not all motors on this datasheet have received a CE Declaration of Conformity. Only the standard S080D, S080T and S080Q motors have been certified to CE standards. The motors and motor options with the following designations have not received a CE Declaration of Conformity, and as such are designated FGA: S080D-1S, S080T-1S, S080Q-2S, S080Q-1S, any S080 motor with Hall Effects.

Note: Metric units guaranteed. Imperial (United States customary) units are calculated.

For assistance in selecting the best motor for your application, contact Nippon Pulse to speak with an applications engineer. 1-540-633-1677

www.nipponpulse.com

The design of the Linear Shaft Motor allows you to replace traditional linear motion systems, such as a standard ball screw, with the Linear Shaft Motor and achieve higher speed and resolution.

To achieve the highest performance with the Linear Shaft Motor system, the entire system structure must be optimized.

Be aware there are various design considerations which are somewhat different from traditional servo system practices. These are the main components needed to make a Linear Shaft Motor system, as well as factors to consider when designing a system.

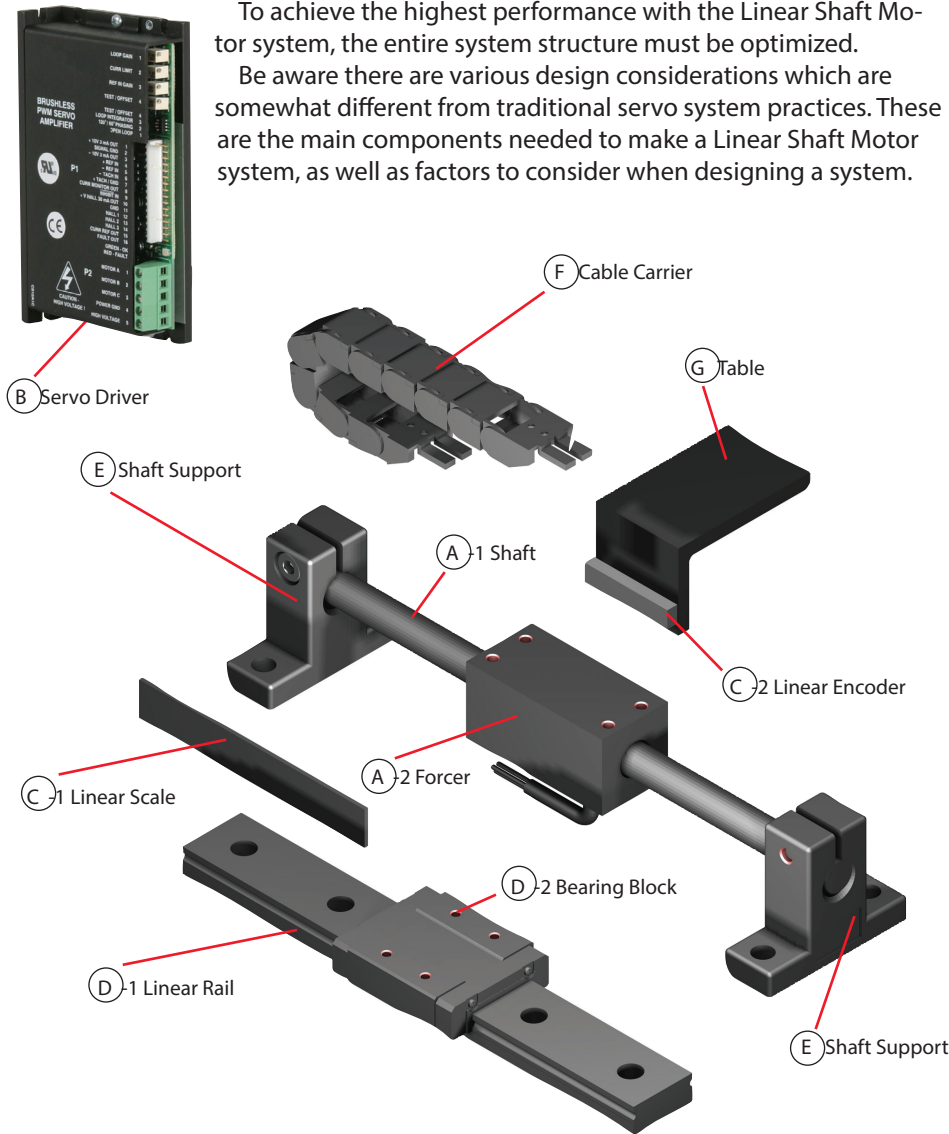

Configuring the Linear Shaft Motor

To configure a system using the Linear Shaft Motor, the following peripheral devices are required:

- A. Linear Shaft Motor
- B. Servo Driver
- C. Linear encoder (optical or magnetic)

Item D (Linear Guide) is a necessary part of a system, but consideration must be given to the application, demand specifications, environmental conditions, and which will be moving--the forcer or the shaft.

The other items, E through G, are optional and will need to be selected depending on the application.

System Design Linear Shaft Motor

Steps to putting together a Linear Shaft Motor System

Choose the Linear Shaft Motor based on force and stroke requirements.

Choose the shaft supports based on design and motor specifications.

Choose the linear guide (bearings) based on cost and smoothness (performance) constraints.

Choose the linear encoder to achieve the required position resolution.

Choose the servo driver to match the power requirements of the Linear Shaft Motor.

Choose the OTL, limit switches/other components and assemble the Linear Shaft Motor system.