

1. Mechanical Dimensions:

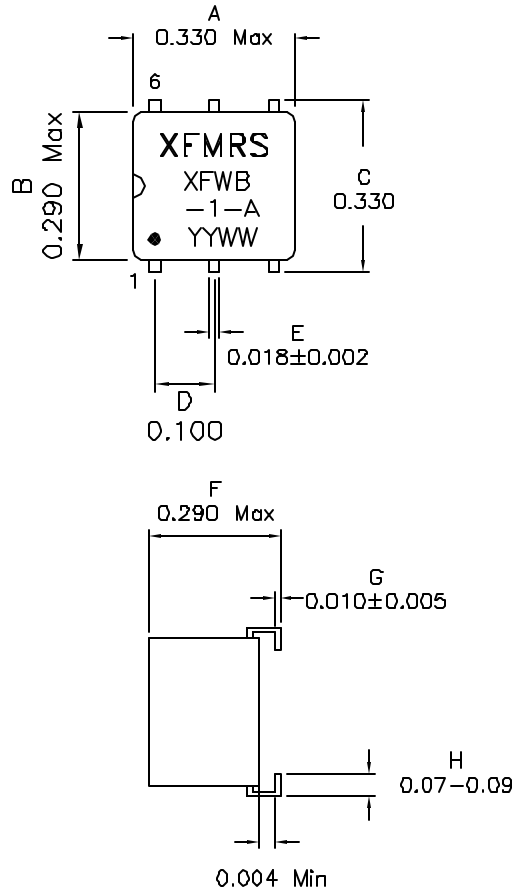

2. Schematic:

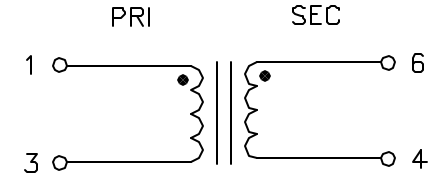

3. Electrical Specifications:

Impedance Ratio: Pri:Sec 1:1 ±2%
 Insertion Loss: 0.08-450MHz 0.60dB Max
 Frequency Response: 0.08- 450MHz
 OCL: Pins 1-3 40uH Min 100KHz 50mV
 DCR: Pins 1-3 0.070 Ohms Max
 OCL: Pins 6-4 40uH Min 100KHz 50mV
 DCR: Pins 6-4 0.070 Ohms Max
 Rated Current: 250mAdc
 Isolation Voltage: 500VAC Pri to Sec
 Isolation Voltage: 500VAC All Wdgs. to Core

Notes:

1. Solderability: Leads shall meet MIL-STD-2026, Method 208H for solderability.
2. Flammability: UL94V-0
3. ASTM oxygen index: > 28%
4. Insulation System: Class F 155°C. UL file E151556
5. Operating Temperature Range: All listed parameters are to be within tolerance from -40°C to +85°C
6. Storage Temperature Range: -55°C to +125°C
7. Aqueous wash compatible
8. SMD Lead Coplanarity: ±0.004"(0.102mm)
9. Electrical and mechanical specifications 100% tested
10. RoHS Compliant Component

DOC REV: A/6

PROPRIETARY Document is the property of XFMRS Group & is not allowed to be duplicated without authorization.

XFMRS Inc www.XFMRS.COM	Title: RF TRANSFORMER		
	UNLESS OTHERWISE SPECIFIED TOLERANCES: .xxx ±0.010 Dimensions in Inch	P/N: XFWB-1-A DWN. CHK.	REV. A Juan Mao YK Liao
SHEET 1 OF 1	APP.	BW	Nov-06-06 Nov-06-06 Nov-06-06