

SYSTEM FEATURES

- 100 MHz to 240 MHz ARM Cortex-M4 with floating-point unit
- 128K Byte to 384K Byte zero-wait-state L1 SRAM with 16K Byte L1 cache
- Up to 2M Byte flash memory
- 16-bit asynchronous external memory interface
- Enhanced PWM units
- Four 3rd/4th order SINC filters for glueless connection of isolated ADCs
- Harmonic analysis engine
- 10/100 Ethernet MAC
- Full Speed USB On-the-Go (OTG)
- Two CAN (controller area network) 2.0B interfaces
- Three UART ports

Two Serial Peripheral Interface (SPI-compatible) ports

Eight 32-bit general-purpose timers

Four Encoder Interfaces, 2 with frequency division

Single power supply

176-lead (24 mm × 24 mm) RoHS compliant LQFP package

120-lead (14 mm × 14 mm) RoHS compliant LQFP package

ANALOG SUBSYSTEM FEATURES

ADC controller (ADCC) and DAC controller (DACC)

Two 16-bit SAR ADCs with up to 24 multiplexed inputs, supporting dual simultaneous conversion in 380 ns (16-bit, no missing codes, ±3.5LSB INL)

Two 12-bit R-string DACs, with output rate up to 50 kHz

Two 2.5 V precision voltage reference outputs

(For details, see [ADC/DAC Specifications on Page 36.](#))

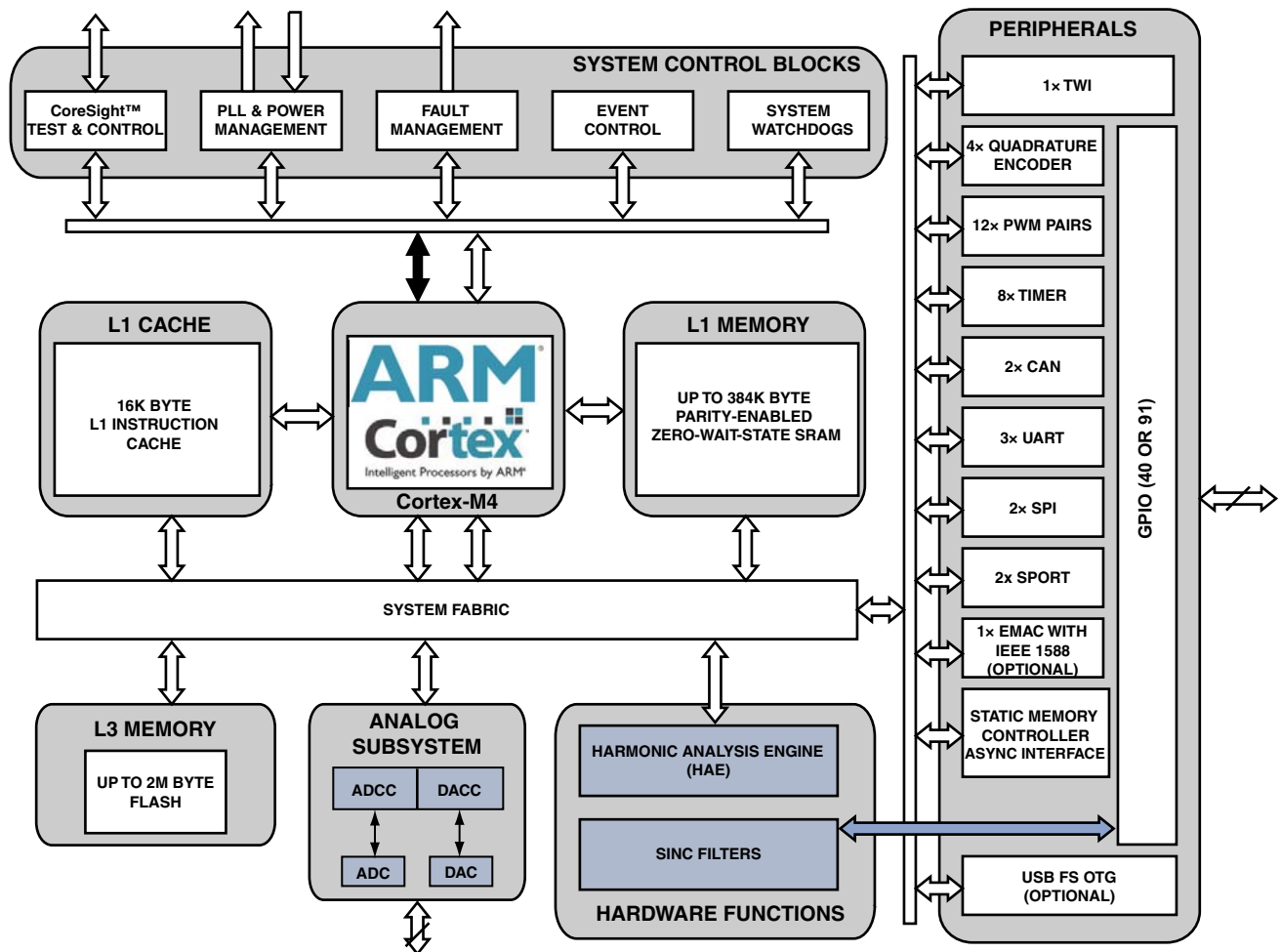

Figure 1. Block Diagram

Rev. PrE

Information furnished by Analog Devices is believed to be accurate and reliable. However, no responsibility is assumed by Analog Devices for its use, nor for any infringements of patents or other rights of third parties that may result from its use. Specifications subject to change without notice. No license is granted by implication or otherwise under any patent or patent rights of Analog Devices. Trademarks and registered trademarks are the property of their respective owners.

TABLE OF CONTENTS

System Features	1	Related Documents	15
Analog Subsystem Features	1	Related Signal Chains	16
General Description	3	ADSP-CM402F/ADSP-CM403F Signal Descriptions	17
Analog Subsystem	4	ADSP-CM402F/ADSP-CM403F Multiplexed Pins	22
ARM Cortex-M4 Core	7	ADSP-CM407F/ADSP-CM408F Signal Descriptions	24
EmbeddedICE	7	ADSP-CM407F/ADSP-CM408F Multiplexed Pins	31
Processor Infrastructure	7	Specifications	34
Memory Architecture	8	Operating Conditions	34
Security Features	10	Electrical Characteristics	35
Processor Reliability Features	10	ADC/DAC Specifications	36
Additional Processor Peripherals	11	Flash Specifications	43
General-Purpose Counters	12	Absolute Maximum Ratings	44
Serial Peripheral Interface (SPI) Ports	12	ESD Sensitivity	44
UART Ports	12	Package Information	44
TWI Controller Interface	12	Timing Specifications	45
Controller Area Network (CAN)	13	Output Drive Currents	72
10/100 Ethernet MAC	13	Environmental Conditions	73
USB 2.0 On-the-Go Dual-Role Device Controller	13	120-Lead LQFP Lead Assignments	74
Clock and Power Management	14	176-Lead LQFP Lead Assignments	77
System Debug	15	Outline Dimensions	81
Development Tools	15	Pre-Release Products	82

REVISION HISTORY

09/13—Revision PrD to Revision PrE

Updated the [Specifications](#) section to include Flash information and timing data for all interfaces. See [Specifications](#) 34

GENERAL DESCRIPTION

The ADSP-CM40x family of mixed-signal control processors is based on the ARM® Cortex-M4™ processor core with floating-point unit operating at frequencies up to 240 MHz and integrating up to 384KB of SRAM memory, 2MB of flash memory, accelerators and peripherals optimized for motor control and photo-voltaic (PV) inverter control and an analog module consisting of two 16-bit SAR-type ADCs and two 12-bit DACs. The ADSP-CM40x family operates from a single voltage supply (VDD_EXT/VDD_ANA), generating its own internal voltage supplies using internal voltage regulators and an external pass transistor.

This family of mixed-signal control processors offers low static power consumption and is produced with a low-power and low-voltage design methodology, delivering world class processor and ADC performance with lower power consumption.

By integrating a rich set of industry-leading system peripherals and memory (shown in Table 1), the ADSP-CM40x mixed-signal control processors are the platform of choice for

next-generation applications that require RISC programmability, advanced communications and leading-edge signal processing in one integrated package. These applications span a wide array of markets including power/motor control, embedded industrial, instrumentation, medical and consumer.

Each ADSP-CM40x family member contains the following modules.

- 8 GP timers with PWM output
- 3-Phase PWM units with up to 4 output pairs per unit
- 2 CAN modules
- 1 two-wire interface (TWI) module
- 3 UARTs

Table 1 provides the additional product features shown by model.

Table 1. ADSP-CM40x Family Product Features

Generic	ADSP-CM402F		ADSP-CM403F			ADSP-CM407F			ADSP-CM408F	
Package	120-Lead LQFP					176-Lead LQFP				
GPIOs	40					91				
EBIU	16-bit Asynchronous/5 Address					16-Bit Asynchronous/24 Address				
ADC ENOB (no averaging)	11+		13+			11+			13+	
ADC Inputs	24					16				
DAC Outputs	2					N/A				
SPORTs	3 Half-SPORTs					4 Half-SPORTs				
Ethernet	N/A					1	N/A	N/A	1	N/A
USB	N/A					1	1	N/A	1	1
External SPI	1					2				
General-Purpose Counters	2					4 (2 with dual-outputs)				
Feature Set Code	E	F	C	E	F	A	B	D	A	B
L1 SRAM (KB)	128	128	384	128	128	384	384	128	384	384
Flash (KB)	512	256	2048	512	256	2048	2048	1024	2048	2048
Core Clock (MHz)	150	100	240	150	100	240	240	150	240	240
Model	ADSP-CM402BSWZ-EF	ADSP-CM402BSWZ-FF	ADSP-CM403BSWZ-CF	ADSP-CM403BSWZ-EF	ADSP-CM403BSWZ-FF	ADSP-CM407BSWZ-AF	ADSP-CM407BSWZ-BF	ADSP-CM407BSWZ-DF	ADSP-CM408BSWZ-AF	ADSP-CM408BSWZ-BF

ANALOG SUBSYSTEM

The processors contain two ADCs and two DACs. Control of these data converters is simplified by a powerful on-chip analog-to-digital conversion controller (ADCC) and a digital-to-analog conversion controller (DACC). The ADCC and DACC are integrated seamlessly into the software programming model, and they efficiently manage the configuration and real-time operation of the ADCs and DACs.

For technical details, see [ADC/DAC Specifications on Page 36](#).

The ADCC provides the mechanism to precisely control execution of timing and analog sampling events on the ADCs. The ADCC supports two-channel (one each—ADC0, ADC1) simultaneous sampling of ADC inputs with TBD ps time offset accuracy (aperture delay), and can deliver 16 channels of ADC data to memory in 3 μ s. Conversion data from the ADCs may be either routed via DMA to memory, or to a destination register via the processor. The ADCC can be configured so that the

two ADCs sample and convert both analog inputs simultaneously or at different times and may be operated in asynchronous or synchronous modes. The best performance can be achieved in synchronous mode.

Likewise, the DACC interfaces to two DACs and has purpose of managing those DACs. Conversion data to the DACs may be either routed from memory through DMA, or from a source register via the processor.

Functional operation and programming for the ADCC and DACC are described in detail in the *ADSP-CM40x Mixed-Signal Control Processor with ARM Cortex-M4 Hardware Reference*.

ADC and DAC features and performance specifications differ by processor model. Simplified block diagrams of the ADCC, DACC and the ADCs and DACs are shown in [Figure 2](#) and [Figure 3](#).

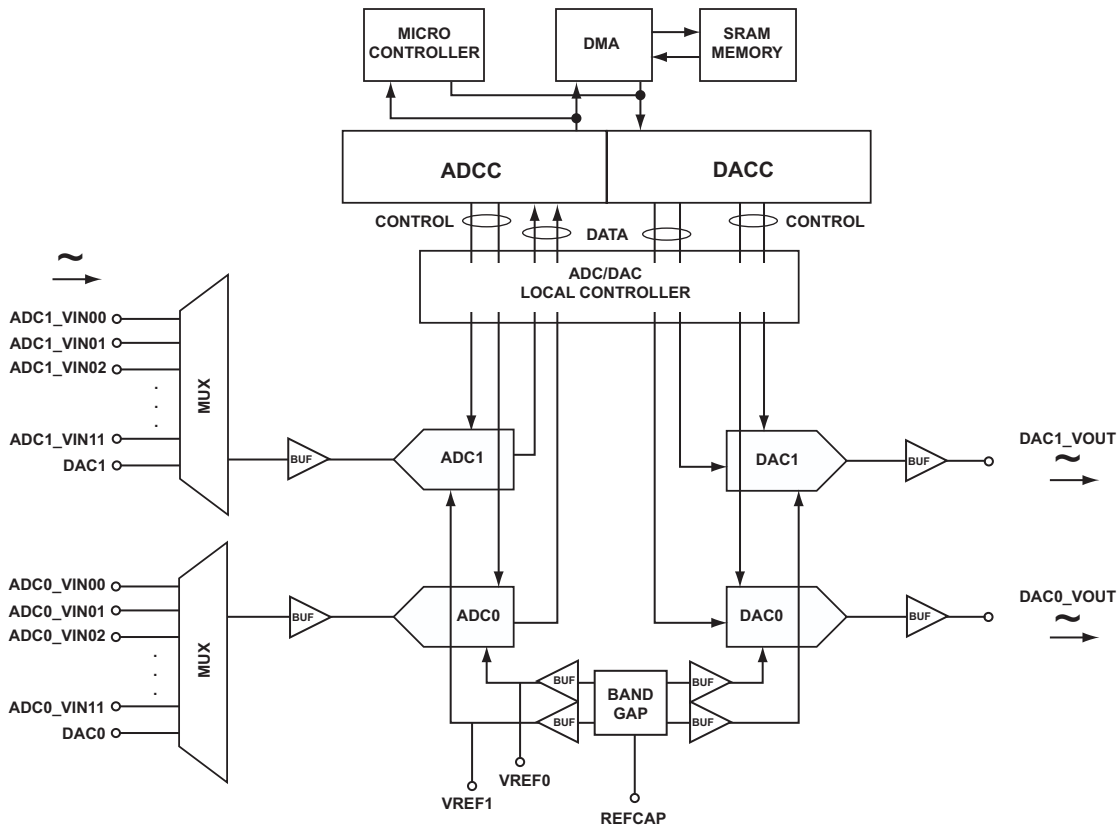

Figure 2. CM402F/CM403F Analog Subsystem Block Diagram

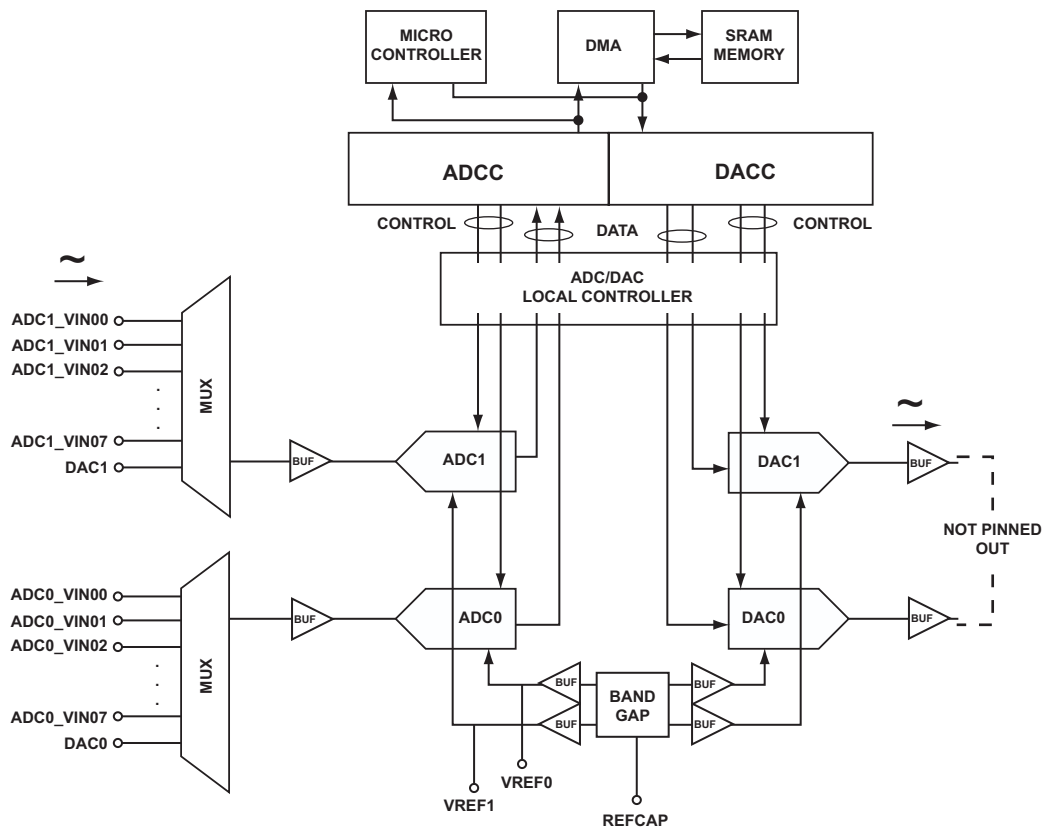

Figure 3. CM407F/CM408F Analog Subsystem Block Diagram

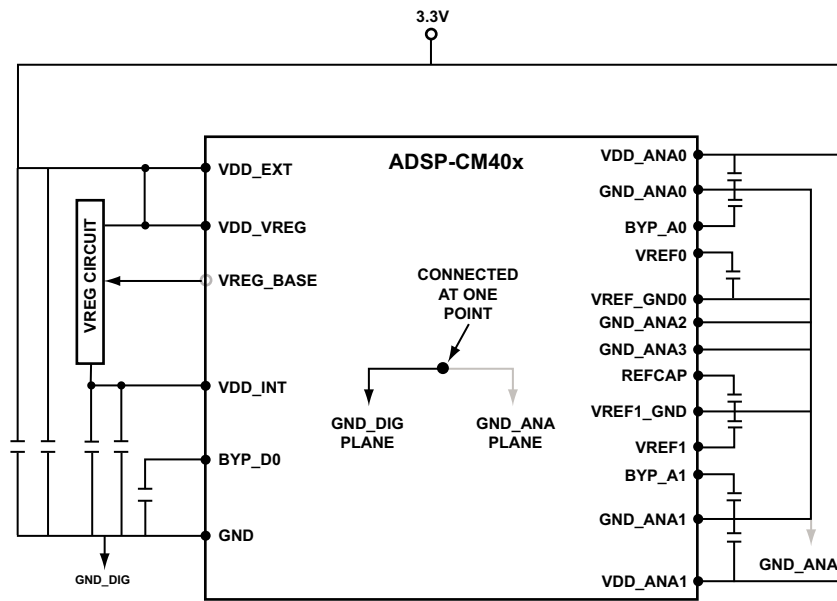

Figure 4. Typical Power Supply Configuration

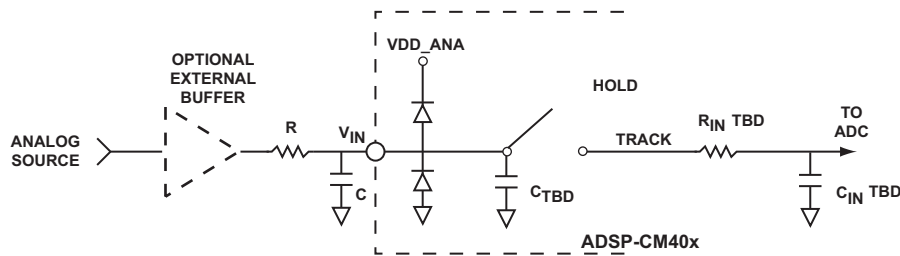

Figure 5. Equivalent Single-Ended Input (Simplified)

Considerations for Best Converter Performance

As with any high performance analog/digital circuit, to achieve best performance, good circuit design and board layout practices should be followed. The power supply and its noise bypass (decoupling), ground return paths and pin connections, and analog/digital routing channel paths and signal shielding, are all of first-order consideration. For application hints of design best practice, see Figure 4 and the *ADSP-CM40x Mixed-Signal Control Processor with ARM Cortex-M4 Hardware Reference*.

ADC Module

The ADC module contains two 16-bit, high speed, low power successive approximation register (SAR) ADCs, allowing for dual simultaneous sampling with each ADC proceeded by a 12-channel multiplexer. See [ADC Specifications on Page 36](#) for detailed performance specifications. Input multiplexers enable up to a combined 26 analog input sources to the ADCs (12 analog inputs plus 1 DAC loopback input per ADC).

The voltage input range requirement for those analog inputs is from 0 V to 2.5 V. All analog inputs are of single-ended design. As with all single-ended inputs, signals from high impedance sources are the most difficult to control, and depending on the

electrical environment, may require an external buffer circuit for signal conditioning (Figure 5). An on-chip buffer between the multiplexer and ADC reduces the need for additional signal conditioning external to the processor. Additionally, each ADC has an on-chip 2.5 V reference that can be overdriven when an external voltage reference is preferred.

DAC Module

The DAC is a 12-bit, low power, string DAC design. The output of the DAC is buffered, and can drive an R/C load to either ground or V_{DD_ANA}. See [DAC Specifications on Page 38](#) for detailed performance specifications. It should be noted that on some models of the processor, the DAC outputs are not pinned out. However, these outputs are always available as one of the multiplexed inputs to the ADCs. This feature may be useful for functional self-check of the converters.

Harmonic Analysis Engine (HAE)

The Harmonic Analysis Engine (HAE) block receives 8 kHz input samples from two source signals whose frequencies are between 45 Hz and 65 Hz. The HAE will then process the input samples and produce output results. The output results consist of power quality measurements of the fundamental and up to 12 additional harmonics.

SINC Filter

The SINC module processes four bit streams using a pair of configurable SINC filters for each bitstream. The purpose of the primary SINC filter of each pair is to produce the filtered and decimated output for the pair. The output may be decimated to any integer rate between 8 and 256 times lower than the input rate. Greater decimation allows greater removal of noise and therefore greater ENOB.

Optional additional filtering outside the SINC module may be used to further increase ENOB. The primary SINC filter output is accessible through transfer to processor memory, or to another peripheral, via DMA.

Each of the four channels is also provided with a low-latency secondary filter with programmable positive and negative over-range detection comparators. These limit detection events can be used to interrupt the core, generate a trigger, or signal a system fault.

ARM CORTEX-M4 CORE

The ARM Cortex-M4, core shown in [Figure 6](#), is a 32-bit reduced instruction set computer (RISC). It uses a single 32-bit bus for instruction and data. The length of the data can be eight bits, 16 bits, or 32 bits. The length of the instruction word is 16 or 32 bits. The controller has the following features.

Cortex-M4 Architecture

- Thumb-2 ISA Technology
- DSP and SIMD extensions
- Single cycle MAC (Up to $32 \times 32 + 64 \rightarrow 64$)
- Hardware Divide Instructions
- Single-precision FPU
- NVIC Interrupt Controller (129 Interrupts and 16 Priorities)
- Memory Protection Unit (MPU)
- Full CoreSight™ Debug, Trace, Breakpoints, Watchpoints, and Cross-Triggers

Microarchitecture

- 3-stage pipeline with branch speculation
- Low-latency interrupt processing with tail chaining

Configurable For Ultra Low Power

- Deep sleep mode, dynamic power management
- Programmable Clock Generator Unit

EmbeddedICE

EmbeddedICE® provides integrated on-chip support for the core. The EmbeddedICE module contains the breakpoint and watch-point registers that allow code to be halted for debugging purposes. These registers are controlled through the JTAG test port.

When a breakpoint or watchpoint is encountered, the processor halts and enters debug state. Once in a debug state, the processor registers can be inspected as well as the Flash/EE, SRAM, and memory mapped registers.

PROCESSOR INFRASTRUCTURE

The following sections provide information on the primary infrastructure components of the ADSP-CM40x processors.

DMA Controllers (DDEs)

The processor contains 17 peripheral DMA channels plus two MDMA streams. DDE channel numbers 0–16 are for peripherals and channels 17–20 are for MDMA.

System Event Controller (SEC)

The SEC manages the enabling and routing of system fault sources through its integrated fault management unit.

Trigger Routing Unit (TRU)

The TRU provides system-level sequence control without core intervention. The TRU maps trigger masters (generators of triggers) to trigger slaves (receivers of triggers). Slave endpoints can be configured to respond to triggers in various ways. Common applications enabled by the TRU include:

- Automatically triggering the start of a DMA sequence after a sequence from another DMA channel completes
- Software triggering
- Synchronization of concurrent activities

Pin Interrupts

Every port pin on the processor can request interrupts in either an edge-sensitive or a level-sensitive manner with programmable polarity. Interrupt functionality is decoupled from GPIO operation. Six system-level interrupt channels (PINT0–5) are reserved for this purpose. Each of these interrupt channels can manage up to 32 interrupt pins. The assignment from pin to interrupt is not performed on a pin-by-pin basis. Rather, groups of eight pins (half ports) can be flexibly assigned to interrupt channels.

Every pin interrupt channel features a special set of 32-bit memory-mapped registers that enable half-port assignment and interrupt management. This includes masking, identification, and clearing of requests. These registers also enable access to the respective pin states and use of the interrupt latches, regardless of whether the interrupt is masked or not. Most control registers feature multiple MMR address entries to write-one-to-set or write-one-to-clear them individually.

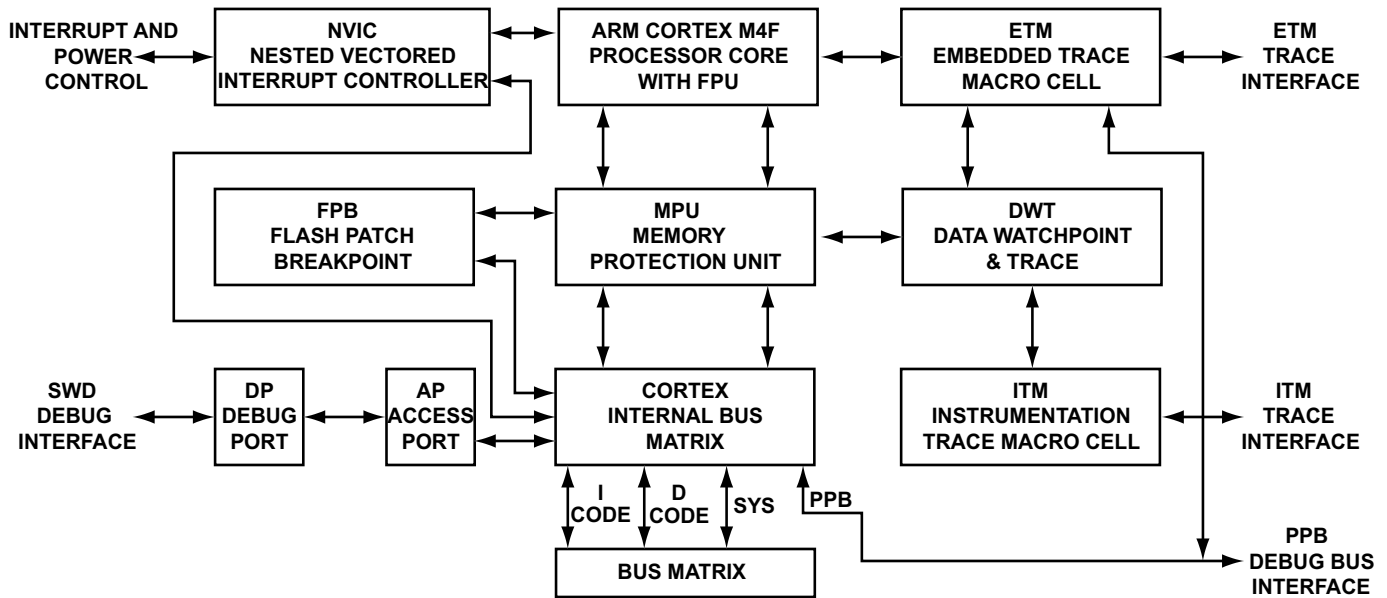

Figure 6. Cortex-M4 Block Diagram

General-Purpose I/O (GPIO)

Each general-purpose port pin can be individually controlled by manipulation of the port control, status, and interrupt registers:

- GPIO direction control register – Specifies the direction of each individual GPIO pin as input or output.
- GPIO control and status registers – A “write one to modify” mechanism allows any combination of individual GPIO pins to be modified in a single instruction, without affecting the level of any other GPIO pins.
- GPIO interrupt mask registers – Allow each individual GPIO pin to function as an interrupt to the processor. GPIO pins defined as inputs can be configured to generate hardware interrupts, while output pins can be triggered by software interrupts.
- GPIO interrupt sensitivity registers – Specify whether individual pins are level- or edge-sensitive and specify—if edge-sensitive—whether just the rising edge or both the rising and falling edges of the signal are significant.

Pin Multiplexing

The processor supports a flexible multiplexing scheme that multiplexes the GPIO pins with various peripherals. A maximum of 4 peripherals plus GPIO functionality is shared by each GPIO pin. All GPIO pins have a bypass path feature—that is, when the output enable and the input enable of a GPIO pin are both active, the data signal before the pad driver is looped back to the receive path for the same GPIO pin. See [ADSP-CM402F/ADSP-CM403F Multiplexed Pins on Page 22](#) and [ADSP-CM407F/ADSP-CM408F Multiplexed Pins on Page 31](#).

MEMORY ARCHITECTURE

The internal and external memory of the ADSP-CM40x processor is shown in [Figure 7](#) and described in the following sections.

ARM Cortex-M4 Memory Subsystem

The memory map of the ADSP-CM40x family is based on the Cortex-M4 model from ARM. By retaining the standardized memory mapping, it becomes easier to port applications across M4 platforms. Only the physical implementation of memories inside the model differs from other vendors.

ADSP-CM40x application development is typically based on memory blocks across CODE/SRAM and external memory regions. Sufficient internal memory is available via internal SRAM and internal flash. Additional external memory devices may be interfaced via the SMC asynchronous memory port, as well as through the SPI0 serial memory interface.

Code Region

Accesses in this region (0x0000_0000 to 0x1FFF_FFFF) are performed by the core on its ICODE and DCODE interfaces, and they target the memory and cache resources within the ADI Cortex-M4F platform component.

- **Boot ROM.** A 32K byte boot ROM executed at system reset. This space supports read-only access by the M4F core only. Note that ROM memory contents cannot be modified by the user.
- **Internal SRAM Code Region.** This memory space contains the application instructions and literal (constant) data which must be executed real time. It supports read/write access by the M4F core and read/write DMA access by system devices. Internal SRAM can be partitioned between

CODE and DATA (SRAM region in M4 space) in 64K byte blocks. Access to this region occurs at core clock speed, with no wait states.

- **Integrated Flash.** This contains the 2M byte flash memory space interfaced via the SPI2 port of the processor. This memory space contains the application instructions and literal (constant) data. Reads from flash memory are directly cached via internal code cache. Direct memory-mapped reads are permitted via SPI memory-mapped protocol.
- **Internal Code Cache.** A zero-wait-state code cache SRAM memory is available internally (not visible in the memory map) to cache instruction access from internal flash as well as any externally connected serial flash and asynchronous memory.
- **MEM-X/MEM-Y.** These are virtual memory blocks which are used as cacheable memory for the code cache. No physical memory device resides inside these blocks. The application code must be compiled against these memory blocks to utilize the cache.

SRAM Region

Accesses in this region (0x2000_0000 to 0x3FFF_FFFF) are performed by the ARM Cortex-M4F core on its SYS interface. The SRAM region of the core can otherwise act as a data region for an application.

- **Internal SRAM Data Region.** This space can contain read/write data. Internal SRAM can be partitioned between CODE and DATA (SRAM region in M4 space) in 64K byte blocks. Access to this region occurs at core clock speed, with no wait states. It supports read/write access by the M4F core and read/write DMA access by system devices. It supports exclusive memory accesses via the global exclusive access monitor within the ADI Cortex-M4F platform. Bit-banding support is also available.

External (Memory-Mapped) Peripheral Region

- **External SPI Flash Support.** Up to 16M byte of external serial quad flash memory optionally connected to the SPI0 port of the processor. Reads from flash memory are directly cached via internal code cache. Direct memory-mapped reads are permitted via SPI memory-mapped protocol.
- **System MMRs.** Various system MMRs reside in this region. Bit-banding support is available for MMRs.

External SRAM Region

- **L2 Asynchronous Memory.** Up to 32M byte × 4 banks of external memory can be optionally connected to the asynchronous memory port (SMC). Code execution from these memory blocks can be optionally cached via internal code cache. Direct R/W data access is also possible.

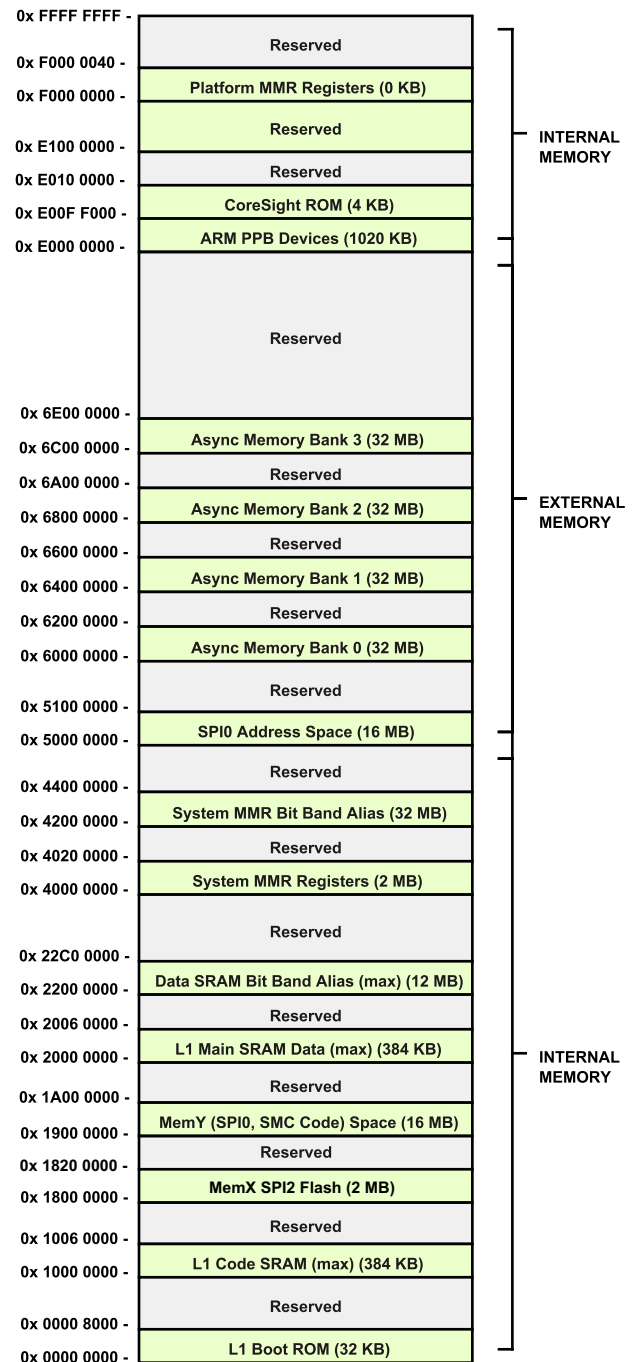

Figure 7. ADSP-CM40x Memory Map

System Region

Accesses in this region (0xE000_0000 to 0xF7FF_FFFF) are performed by the ARM Cortex-M4F core on its SYS interface, and are handled within the ADI Cortex-M4F platform. The MPU may be programmed to limit access to this space to privileged mode only.

- **CoreSight ROM.** The ROM table entries point to the debug components of the processor.
- **ARM PPB Peripherals.** This space is defined by ARM and occupies the bottom 256K byte of the SYS region (0xE000_0000 to 0xE004_0000). The space supports read/write access by the M4F core to the ARM core's internal peripherals (MPU, ITM, DWT, FPB, SCS, TPIU, ETM) and the CoreSight ROM. It is not accessible by system DMA.
- **Platform Control Registers.** This space has registers within the ADI Cortex-M4F platform component that control the ARM core, its memory, and the code cache. It is accessible by the M4F core via its SYS port (but is not accessible by system DMA).

Static Memory Controller (SMC)

The SMC can be programmed to control up to four banks of external memories or memory-mapped devices, with very flexible timing parameters. Each bank occupies a 32M byte segment regardless of the size of the device used.

Booting

The processor has several mechanisms for automatically loading internal and external memory after a reset. The boot mode is defined by the SYS_BMODE input pins dedicated for this purpose. There are two categories of boot modes. In master boot modes, the processor actively loads data from a serial memory. In slave boot modes, the processor receives data from external host devices.

The boot modes are shown in [Table 2](#). These modes are implemented by the SYS_BMODE bits of the RCU_CTL register and are sampled during power-on resets and software-initiated resets.

Table 2. Boot Modes

SYS_BMODE[1:0] Setting	Description
00	No boot/Idle. The processor does not boot. Rather the boot kernel executes an IDLE instruction.
01	Flash Boot. Boot from integrated Flash memory through the SPI2. For derivatives with no flash, the processor boots through the SPI0 peripheral configured as a master.
10	SPI Slave Boot. Boot through the SPI0 peripheral configured as a slave.
11	UART Boot. Boot through the UART0 peripheral configured as a slave.

SECURITY FEATURES

The processor provides a combination of hardware and software protection mechanisms that lock out access to the part in secure mode, but grant access in open mode. These mechanisms include password-protected slave boot modes (SPI and UART), as well as password-protected JTAG/SWD debug interfaces.

PROCESSOR RELIABILITY FEATURES

The processor provides the following features which can enhance or help achieve certain levels of system safety and reliability. While the level of safety is mainly dominated by system considerations, the following features are provided to enhance robustness.

Multi-Parity-Bit-Protected L1 Memories

In the processor's SRAM and cache L1 memory space, each word is protected by multiple parity bits to detect the single event upsets that occur in all RAMs.

Cortex MPU

The MPU divides the memory map into a number of regions, and allows the system programmer to define the location, size, access permissions, and memory attributes of each region. It supports independent attribute settings for each region, overlapping regions, and export of memory attributes to the system.

For more information, refer to <http://infocenter.arm.com/>

System Protection

All system resources and L2 memory banks can be controlled by either the processor core, memory-to-memory DMA, or the debug unit. A system protection unit (SPU) enables write accesses to specific resources that are locked to a given master. System protection is enabled in greater granularity for some modules through a *global lock* concept.

Watchpoint Protection

The primary purpose of watchpoints and hardware breakpoints is to serve emulator needs. When enabled, they signal an emulator event whenever user-defined system resources are accessed or a core executes from user-defined addresses. Watchdog events can be configured such that they signal the events to the core or to the SEC.

Software Watchdog

The on-chip watchdog timer can provide software-based supervision of the ADSP-CM40x core.

Signal Watchdogs

The eight general-purpose timers feature two modes to monitor off-chip signals. The Watchdog Period mode monitors whether external signals toggle with a period within an expected range. The Watchdog Width mode monitors whether the pulse widths of external signals are in an expected range. Both modes help to detect incorrect undesired toggling (or lack thereof) of system-level signals.

Oscillator Watchdog

The oscillator watchdog monitors the external clock oscillator, and can detect the absence of clock as well as incorrect harmonic oscillation. The oscillator watchdog detection signal is routed to the fault management portion of the System Event Controller.

Low-Latency Sinc Filter Over-range Detection

The SINC filter units provide a low-latency secondary filter with programmable positive and negative limit detectors for each input channel. These may be used to monitor an isolation ADC bitstream for over- or under-range conditions with a filter group delay as low as 0.7 μ s on a 10 MHz bitstream. The secondary SINC filter events can be used to interrupt the core, to trigger other events directly in hardware using the Trigger Routing Unit (TRU), or to signal the Fault Management Unit of a system fault.

Up/Down Count Mismatch Detection

The GP counter can monitor external signal pairs, such as request/grant strobes. If the edge count mismatch exceeds the expected range, the up/down counter can flag this to the processor or to the SEC.

Fault Management

The fault management unit is part of the system event controller (SEC). Most system events can be defined as faults. If defined as such, the SEC forwards the event to its fault management unit which may automatically reset the entire device for reboot, or simply toggle the SYS_FAULT output pin to signal off-chip hardware. Optionally, the fault management unit can delay the action taken via a keyed sequence, to provide a final chance for the core to resolve the crisis and to prevent the fault action from being taken.

ADDITIONAL PROCESSOR PERIPHERALS

The processor contains a rich set of peripherals connected to the core via several concurrent high-bandwidth buses, providing flexibility in system configuration as well as excellent overall system performance (see the block diagram on Page 1).

The processor contains high speed serial and parallel ports, an interrupt controller for flexible management of interrupts from the on-chip peripherals or external sources, and power management control functions to tailor the performance and power characteristics of the processor and system to many application scenarios.

The following sections describe additional peripherals that were not described in the previous sections.

Timers

The processor includes several timers which are described in the following sections.

General-Purpose Timers

The GP timer unit provides eight general-purpose programmable timers. Each timer has an external pin that can be configured either as a pulse width modulator (PWM) or timer output, as an

input to clock the timer, or as a mechanism for measuring pulse widths and periods of external events. These timers can be synchronized to an external clock input on the TMRx pins, an external signal on the TM0_CLK input pin, or to the internal SYSCLK.

The timer unit can be used in conjunction with the UARTs and the CAN controller to measure the width of the pulses in the data stream to provide a software auto-baud detect function for the respective serial channels.

The timer can generate interrupts to the processor core, providing periodic events for synchronization to either the system clock or to external signals. Timer events can also trigger other peripherals via the TRU (for instance, to signal a fault).

Watchdog Timer

The core includes a 32-bit timer, which may be used to implement a software watchdog function. A software watchdog can improve system availability by forcing the processor to a known state, via generation of a hardware reset, nonmaskable interrupt (NMI), or general-purpose interrupt, if the timer expires before being reset by software. The programmer initializes the count value of the timer, enables the appropriate interrupt, then enables the timer. Thereafter, the software must reload the counter before it counts to zero from the programmed value. This protects the system from remaining in an unknown state where software, which would normally reset the timer, has stopped running due to an external noise condition or software error.

After a reset, software can determine if the watchdog was the source of the hardware reset by interrogating a status bit that is set only upon a watchdog generated reset.

3-Phase PWM Units

The Pulse Width Modulator (PWM) unit provides duty cycle and phase control capabilities to a resolution of one system clock cycle (SYSCLK). The Heightened Precision PWM (HPPWM) module provides increased performance to the PWM unit by increasing its resolution by several bits, resulting in Enhanced Precision levels. Additional features include:

- 16-bit center-based PWM generation unit
- Programmable PWM pulse width
- Single/double update modes
- Programmable dead time and switching frequency
- Twos-complement implementation which permits smooth transition to full ON and full OFF states
- Dedicated asynchronous PWM shutdown signal

Each PWM block integrates a flexible and programmable 3-phase PWM waveform generator that can be programmed to generate the required switching patterns to drive a 3-phase voltage source inverter for ac induction motor (ACIM) or permanent magnet synchronous motor (PMSM) control. In addition, the PWM block contains special functions that considerably simplify the generation of the required PWM

switching patterns for control of the electronically commutated motor (ECM) or brushless dc motor (BDCM). Software can enable a special mode for switched reluctance motors (SRM).

The eight PWM output signals (per PWM unit) consist of four high-side drive signals and four low-side drive signals. The polarity of a generated PWM signal can be set with software, so that either active HI or active LO PWM patterns can be produced.

Each PWM unit features a dedicated asynchronous shutdown pin which (when brought low) instantaneously places all PWM outputs in the OFF state.

Serial Ports (SPORTs)

The synchronous serial ports provide an inexpensive interface to a wide variety of digital and mixed-signal peripheral devices such as Analog Devices' audio codecs, ADCs, and DACs. The serial ports are made up of two data lines, a clock, and frame sync. The data lines can be programmed to either transmit or receive and each data line has a dedicated DMA channel.

Serial port data can be automatically transferred to and from on-chip memory/external memory via dedicated DMA channels. Each of the serial ports can work in conjunction with another serial port to provide TDM support. In this configuration, one SPORT provides two transmit signals while the other SPORT provides the two receive signals. The frame sync and clock are shared.

Serial ports operate in five modes:

- Standard DSP serial mode
- Multichannel (TDM) mode
- I²S mode
- Packed I²S mode
- Left-justified mode

GENERAL-PURPOSE COUNTERS

The 32-bit counter can operate in general-purpose up/down count modes and can sense 2-bit quadrature or binary codes as typically emitted by industrial drives or manual thumbwheels. Count direction is either controlled by a level-sensitive input pin or by two edge detectors.

A third counter input can provide flexible zero marker support and can alternatively be used to input the push-button signal of thumb wheels. All three pins have a programmable debouncing circuit.

The GP Counter can also support a programmable M/N frequency scaling of the CNT_CUD and CNT_CDG pins onto output pins in Quadrature Encoding Mode.

Internal signals forwarded to each general-purpose timer enable these timers to measure the intervals between count events. Boundary registers enable auto-zero operation or simple system warning by interrupts when programmable count values are exceeded.

SERIAL PERIPHERAL INTERFACE (SPI) PORTS

The processor contains the SPI-compatible port that allows the processor to communicate with multiple SPI-compatible devices.

In its simplest mode, the SPI interface uses three pins for transferring data: two data pins Master Output-Slave Input and Master Input-Slave Output (SPI_MOSI and SPI_MISO) and a clock pin, SPI_CLK. A SPI chip select input pin (SPI_SS) lets other SPI devices select the processor, and seven SPI chip select output pins (SPI_SELn) let the processor select other SPI devices. The SPI select pins are reconfigured general-purpose I/O pins. Using these pins, the SPI provides a full-duplex, synchronous serial interface, which supports both master and slave modes and multimaster environments.

The SPI port's baud rate and clock phase/polarities are programmable, and it has integrated DMA channels for both transmit and receive data streams.

UART PORTS

The processor provides full-duplex universal asynchronous receiver/transmitter (UART) ports, which are fully compatible with PC-standard UARTs. Each UART port provides a simplified UART interface to other peripherals or hosts, supporting full-duplex, DMA-supported, asynchronous transfers of serial data. A UART port includes support for five to eight data bits, and none, even, or odd parity. Optionally, an additional address bit can be transferred to interrupt only addressed nodes in multi-drop bus (MDB) systems. A frame is terminated by one, one and a half, two or two and a half stop bits.

The UART ports support automatic hardware flow control through the Clear To Send (CTS) input and Request To Send (RTS) output with programmable assertion FIFO levels.

To help support the Local Interconnect Network (LIN) protocols, a special command causes the transmitter to queue a break command of programmable bit length into the transmit buffer. Similarly, the number of stop bits can be extended by a programmable inter-frame space.

The capabilities of the UARTs are further extended with support for the Infrared Data Association (IrDA®) serial infrared physical layer link specification (SIR) protocol.

TWI CONTROLLER INTERFACE

The processor includes a 2-wire interface (TWI) module for providing a simple exchange method of control data between multiple devices. The TWI module is compatible with the widely used I²C bus standard. The TWI module offers the capabilities of simultaneous master and slave operation and support for both 7-bit addressing and multimedia data arbitration. The TWI interface utilizes two pins for transferring clock (TWI_SCL) and data (TWI_SDA) and supports the protocol at speeds up to 400k bits/sec. The TWI interface pins are compatible with 5 V logic levels.

Additionally, the TWI module is fully compatible with serial camera control bus (SCCB) functionality for easier control of various CMOS camera sensor devices.

CONTROLLER AREA NETWORK (CAN)

The CAN controller implements the CAN 2.0B (active) protocol. This protocol is an asynchronous communications protocol used in both industrial and automotive control systems. The CAN protocol is well suited for control applications due to its capability to communicate reliably over a network. This is because the protocol incorporates CRC checking, message error tracking, and fault node confinement.

The CAN controller offers the following features:

- 32 mailboxes (8 receive only, 8 transmit only, 16 configurable for receive or transmit).
- Dedicated acceptance masks for each mailbox.
- Additional data filtering on first two bytes.
- Support for both the standard (11-bit) and extended (29-bit) identifier (ID) message formats.
- Support for remote frames.
- Active or passive network support.
- CAN wakeup from hibernation mode (lowest static power consumption mode).
- Interrupts, including: TX complete, RX complete, error and global.

An additional crystal is not required to supply the CAN clock, as the CAN clock is derived from a system clock through a programmable divider.

10/100 ETHERNET MAC

The processor can directly connect to a network by way of an embedded fast Ethernet media access controller (MAC) that supports both 10-BaseT (10M bits/sec) and 100-BaseT (100M bits/sec) operation. The 10/100 Ethernet MAC peripheral on the processor is fully compliant to the IEEE 802.3-2002 standard. It provides programmable features designed to minimize supervision, bus use, or message processing by the rest of the processor system.

Some standard features are:

- Support for RMIi protocols for external PHYs
- Full duplex and half duplex modes
- Media access management (in half-duplex operation)
- Flow control
- Station management: generation of MDC/MDIO frames for read-write access to PHY registers

Some advanced features are:

- Automatic checksum computation of IP header and IP payload fields of Rx frames
- Independent 32-bit descriptor-driven receive and transmit DMA channels
- Frame status delivery to memory through DMA, including frame completion semaphores for efficient buffer queue management in software

- Tx DMA support for separate descriptors for MAC header and payload to eliminate buffer copy operations
- Convenient frame alignment modes
- 47 MAC management statistics counters with selectable clear-on-read behavior and programmable interrupts on half maximum value
- Advanced power management
- Magic packet detection and wakeup frame filtering
- Support for 802.3Q tagged VLAN frames
- Programmable MDC clock rate and preamble suppression

IEEE 1588 Support

The IEEE 1588 standard is a precision clock synchronization protocol for networked measurement and control systems. The processor includes hardware support for IEEE 1588 with an integrated precision time protocol synchronization engine. This engine provides hardware assisted time stamping to improve the accuracy of clock synchronization between PTP nodes. The main features of the engine are:

- Support for both IEEE 1588-2002 and IEEE 1588-2008 protocol standards
- 64-bit hardware assisted time stamping for transmit and receive frames capable of up to 10 ns resolution
- Identification of PTP message type, version, and PTP payload in frames sent directly over Ethernet and transmission of the status
- Coarse and fine correction methods for system time update
- Alarm features: target time can be set to interrupt when system time reaches target time
- Pulse-Per-Second output for physical representation of the system time. Flexibility to control the Pulse-Per-Second (PPS) output signal including control of start time, stop time, PPS output width and interval
- Automatic detection and time stamping of PTP messages over IPv4, IPv6 and Ethernet packets
- Multiple input clock sources (SYSCLK, RMIi clock, external clock)
- Auxiliary snapshot to time stamp external events

USB 2.0 ON-THE-GO DUAL-ROLE DEVICE CONTROLLER

The USB 2.0 OTG dual-role device controller provides a low-cost connectivity solution for the growing adoption of this bus standard in industrial applications, as well as consumer mobile devices such as cell phones, digital still cameras, and MP3 players. The USB 2.0 controller is a full-speed-only (FS) interface that allows these devices to transfer data using a point-to-point USB connection without the need for a PC host. The module can operate in a traditional USB peripheral-only mode as well as the host mode presented in the On-the-Go (OTG) supplement to the USB 2.0 specification.

CLOCK AND POWER MANAGEMENT

The processor provides three operating modes, each with a different performance/power profile. Control of clocking to each of the processor peripherals also reduces power consumption. See [Table 3](#) for a summary of the power settings for each mode.

Table 3. Power Settings

Mode	PLL	PLL Bypassed	f _{CCLK}	f _{SYSCLK}	Core Power
Full On	Enabled	No	Enabled	Enabled	On
Active	Enabled	Yes	Enabled	Enabled	On
	Disabled	Yes	Enabled	Enabled	On
Deep Sleep	Disabled	—	Disabled	Disabled	On

Crystal Oscillator (SYS_XTAL)

The processor can be clocked by an external crystal, a sine wave input, or a buffered, shaped clock derived from an external clock oscillator. If an external clock is used, it should be a TTL compatible signal and must not be halted, changed, or operated below the specified frequency during normal operation. This signal is connected to the processor’s SYS_CLKIN pin. When an external clock is used, the SYS_XTAL pin must be left unconnected. Alternatively, because the processor includes an on-chip oscillator circuit, an external crystal may be used.

Oscillator Watchdog

A programmable Oscillator Watchdog unit is provided to allow verification of proper startup and harmonic mode of the external crystal. This allows the user to specify the expected frequency of oscillation, and to enable detection of non-oscillation and improper-oscillation faults. These events can be routed to the SYS_FAULT output pin and/or to cause a reset of the part.

Clock Generation

The clock generation unit (CGU) generates all on-chip clocks and synchronization signals. Multiplication factors are programmed to the PLLs to define the PLLCLK frequency. Programmable values divide the PLLCLK frequency to generate the core clock (CCLK), the system clocks (SYSCLK) and the output clock (OCLK). This is illustrated in [Figure 8 on Page 34](#).

Writing to the CGU control registers does not affect the behavior of the PLL immediately. Registers are first programmed with a new value, and the PLL logic executes the changes so that it transitions smoothly from the current conditions to the new ones.

SYS_CLKIN oscillations start when power is applied to the V_{DD_EXT} pins. The rising edge of SYS_HWRST can be applied as soon as all voltage supplies are within specifications (see [Operating Conditions on Page 34](#)), and SYS_CLKIN oscillations are stable.

A SYS_CLKOUT output pin has programmable options to output divided-down versions of the on-chip clocks, including USB clocks. By default, the SYS_CLKOUT pin drives a buffered version of the SYS_CLKIN input. Clock generation faults (for example PLL unlock) may trigger a reset by hardware.

Clock Out/External Clock

SYS_CLKOUT can be used to output one of several different clocks used on the processor. The clocks shown in [Table 4](#) can be outputs from SYS_CLKOUT.

Table 4. SYS_CLKOUT Source and Divider Options

Clock Source	Divider
CCLK (core clock)	By 4
SYSCLK (system clock)	None
OCLK (output clock)	Programmable
USBCLK	Programmable
CLKBUF	None, direct from SYS_CLKIN

Power Management

As shown in [Table 5](#) and [Figure 4 on Page 6](#), the processor supports three different power domains, V_{DD_INT}, V_{DD_EXT} and V_{DD_ANA}. By isolating the internal logic of the processor into its own power domain, separate from other I/O, the processor can take advantage of dynamic power management without affecting the other I/O devices. There are no sequencing requirements for the various power domains, but all domains must be powered according to the appropriate [Specifications](#) table for processor operating conditions; even if the feature/peripheral is not used.

The dynamic power management feature of the processor allows the processor’s core clock frequency (f_{CCLK}) to be dynamically controlled.

Table 5. Power Domains

Power Domain	Pin
All internal logic	V _{DD_INT}
Digital I/O	V _{DD_EXT}
Analog	V _{DD_ANA}

The power dissipated by a processor is largely a function of its clock frequency and the square of the operating voltage. For example, reducing the clock frequency by 25% results in a 25% reduction in dynamic power dissipation. For more information on power pins, see [Operating Conditions on Page 34](#).

Full-On Operating Mode—Maximum Performance

In the full-on mode, the PLL is enabled and is not bypassed, providing capability for maximum operational frequency. This is the execution state in which maximum performance can be achieved. The processor core and all enabled peripherals run at full speed.

For more information about PLL controls, see the “Dynamic Power Management” chapter in the *ADSP-CM40x Mixed-Signal Control Processor with ARM Cortex-M4 Hardware Reference*.

Deep Sleep Operating Mode—Maximum Dynamic Power Savings

The deep sleep mode maximizes dynamic power savings by disabling the clocks to the processor core and to all synchronous peripherals. Asynchronous peripherals may still be running but cannot access internal resources or external memory.

Voltage Regulation for VDD_INT

TBD

Reset Control Unit

Reset is the initial state of the whole processor or of the core and is the result of a hardware or software triggered event. In this state, all control registers are set to their default values and functional units are idle. Exiting a core only reset starts with the core being ready to boot.

The Reset Control Unit (RCU) controls how all the functional units enter and exit reset. Differences in functional requirements and clocking constraints define how reset signals are generated. Programs must guarantee that none of the reset functions puts the system into an undefined state or causes resources to stall.

From a system perspective reset is defined by both the reset target and the reset source as described below.

Target defined:

- Hardware Reset – All functional units are set to their default states without exception. History is lost.
- System Reset – All functional units except the RCU are set to their default states.
- The processor core-only reset – Affects the core only. The system software should guarantee that the core in reset state is not accessed by any bus master.

Source defined:

- Hardware Reset – The $\overline{\text{SYS_HWRST}}$ input signal is asserted active (pulled down).
- System Reset – May be triggered by software (writing to the RCU_CTL register) or by another functional unit such as the dynamic power management (DPM) unit or any of the system event controller (SEC), trigger routing unit (TRU), or emulator inputs.
- Trigger request (peripheral).

SYSTEM DEBUG

The processor includes various features that allow for easy system debug. These are described in the following sections.

JTAG debug and Serial Wire Debug Port (SWJ-DP)

SWJ-DP is a combined JTAG-DP and SW-DP that enables either a Serial Wire Debug (SWD) or JTAG probe to be connected to a target. SWD signals share the same pins as JTAG. There is an auto detect mechanism that switches between JTAG-DP and SW-DP depending on which special data sequence is used the emulator pod transmits to the JTAG pins. The SWJ-DP behaves as a JTAG target if normal JTAG sequences are sent to it and as a single wire target if the SW_DP sequence is transmitted.

Embedded Trace Macrocell (ETM) and Instrumentation Trace Macrocell (ITM)

The ADSP-CM40x processors support both Embedded Trace Macrocell (ETM) and Instrumentation Trace Macrocell (ITM). These both offer an optional debug component that enables logging of real-time instruction and data flow within the CPU core. This data is stored and read through special debugger pods that have the trace feature capability. The ITM is a single-data pin feature and the ETM is a 4-data pin feature.

System Watchpoint Unit

The System Watchpoint Unit (SWU) is a single module which connects to a single system bus and provides for transaction monitoring. One SWU is attached to the bus going to each system slave. The SWU provides ports for all system bus address channel signals. Each SWU contains four match groups of registers with associated hardware. These four SWU match groups operate independently, but share common event (interrupt and trigger) outputs.

DEVELOPMENT TOOLS

The ADSP-CM40x processor is supported with a set of highly sophisticated and easy-to-use development tools for embedded applications. For more information, see the Analog Devices website.

RELATED DOCUMENTS

TBD

Instruction Set Description

See ARM documents.

RELATED SIGNAL CHAINS

A *signal chain* is a series of signal-conditioning electronic components that receive input (data acquired from sampling either real-time phenomena or from stored data) in tandem, with the output of one portion of the chain supplying input to the next. Signal chains are often used in signal processing applications to gather and process data or to apply system controls based on analysis of real-time phenomena. For more information about this term and related topics, see the “signal chain” entry in the [Glossary of EE Terms](#) on the Analog Devices website.

Analog Devices eases signal processing system development by providing signal processing components that are designed to work together well. A tool for viewing relationships between specific applications and related components is available on the www.analog.com website.

The Application Signal Chains page in the Circuits from the Lab™ site (<http://www.analog.com/circuits>) provides:

- Graphical circuit block diagram presentation of signal chains for a variety of circuit types and applications
- Drill down links for components in each chain to selection guides and application information
- Reference designs applying best practice design techniques

ADSP-CM402F/ADSP-CM403F SIGNAL DESCRIPTIONS

Table 6 identifies each signal on the chip, describes the signal, and lists the driver type, port, and lead name.

Table 6. ADSP-CM402F/ADSP-CM403F Signal Descriptions

Signal	Description	Driver Type	Port	Lead Name
ADC0_VIN00	Channel 0 Single-Ended Analog Input for ADC0	TBD	Not Muxed	ADC0_VIN00
ADC0_VIN01	Channel 1 Single-Ended Analog Input for ADC0	TBD	Not Muxed	ADC0_VIN01
ADC0_VIN02	Channel 2 Single-Ended Analog Input for ADC0	TBD	Not Muxed	ADC0_VIN02
ADC0_VIN03	Channel 3 Single-Ended Analog Input for ADC0	TBD	Not Muxed	ADC0_VIN03
ADC0_VIN04	Channel 4 Single-Ended Analog Input for ADC0	TBD	Not Muxed	ADC0_VIN04
ADC0_VIN05	Channel 5 Single-Ended Analog Input for ADC0	TBD	Not Muxed	ADC0_VIN05
ADC0_VIN06	Channel 6 Single-Ended Analog Input for ADC0	TBD	Not Muxed	ADC0_VIN06
ADC0_VIN07	Channel 7 Single-Ended Analog Input for ADC0	TBD	Not Muxed	ADC0_VIN07
ADC0_VIN08	Channel 8 Single-Ended Analog Input for ADC0	TBD	Not Muxed	ADC0_VIN08
ADC0_VIN09	Channel 9 Single-Ended Analog Input for ADC0	TBD	Not Muxed	ADC0_VIN09
ADC0_VIN10	Channel 10 Single-Ended Analog Input for ADC0	TBD	Not Muxed	ADC0_VIN10
ADC0_VIN11	Channel 11 Single-Ended Analog Input for ADC0	TBD	Not Muxed	ADC0_VIN11
ADC1_VIN00	Channel 0 Single-Ended Analog Input for ADC1	TBD	Not Muxed	ADC1_VIN00
ADC1_VIN01	Channel 1 Single-Ended Analog Input for ADC1	TBD	Not Muxed	ADC1_VIN01
ADC1_VIN02	Channel 2 Single-Ended Analog Input for ADC1	TBD	Not Muxed	ADC1_VIN02
ADC1_VIN03	Channel 3 Single-Ended Analog Input for ADC1	TBD	Not Muxed	ADC1_VIN03
ADC1_VIN04	Channel 4 Single-Ended Analog Input for ADC1	TBD	Not Muxed	ADC1_VIN04
ADC1_VIN05	Channel 5 Single-Ended Analog Input for ADC1	TBD	Not Muxed	ADC1_VIN05
ADC1_VIN06	Channel 6 Single-Ended Analog Input for ADC1	TBD	Not Muxed	ADC1_VIN06
ADC1_VIN07	Channel 7 Single-Ended Analog Input for ADC1	TBD	Not Muxed	ADC1_VIN07
ADC1_VIN08	Channel 8 Single-Ended Analog Input for ADC1	TBD	Not Muxed	ADC1_VIN08
ADC1_VIN09	Channel 9 Single-Ended Analog Input for ADC1	TBD	Not Muxed	ADC1_VIN09
ADC1_VIN10	Channel 10 Single-Ended Analog Input for ADC1	TBD	Not Muxed	ADC1_VIN10
ADC1_VIN11	Channel 11 Single-Ended Analog Input for ADC1	TBD	Not Muxed	ADC1_VIN11
BYP_A0	On-chip Analog Power Regulation Bypass Filter Node for ADC0 (see recommended bypass - Figure 4 on Page 6)	TBD	Not Muxed	BYP_A0
BYP_A1	On-chip Analog Power Regulation Bypass Filter Node for ADC1 (see recommended bypass - Figure 4 on Page 6)	TBD	Not Muxed	BYP_A1
BYP_D0	On-chip Digital Power Regulation Bypass Filter Node for Analog Subsystem (see recommended bypass - Figure 4 on Page 6)	TBD	Not Muxed	BYP_D0
CAN0_RX	CAN0 Receive	TBD	B	PB_15
CAN0_TX	CAN0 Transmit	TBD	C	PC_00
CAN1_RX	CAN1 Receive	TBD	B	PB_10
CAN1_TX	CAN1 Transmit	TBD	B	PB_11
CNT0_DG	CNT0 Count Down and Gate	TBD	B	PB_02
CNT0_OUTA	CNT0 Output Divider A	TBD	B	PB_13
CNT0_OUTB	CNT0 Output Divider B	TBD	B	PB_14
CNT0_UD	CNT0 Count Up and Direction	TBD	B	PB_01
CNT0_ZM	CNT0 Count Zero Marker	TBD	B	PB_00
CNT1_DG	CNT1 Count Down and Gate	TBD	B	PB_05
CNT1_UD	CNT1 Count Up and Direction	TBD	B	PB_04
CNT1_ZM	CNT1 Count Zero Marker	TBD	B	PB_03

Table 6. ADSP-CM402F/ADSP-CM403F Signal Descriptions (Continued)

Signal	Description	Driver Type	Port	Lead Name
DAC0_VOUT	Analog Voltage Output 0	TBD	Not Muxed	DAC0_VOUT
DAC1_VOUT	Analog Voltage Output 1	TBD	Not Muxed	DAC1_VOUT
GND	Digital Ground	TBD	Not Muxed	GND
GND_ANA0	Analog Ground return for VDD_ANA0 (see recommended bypass - Figure 4 on Page 6)	TBD	Not Muxed	GND_ANA0
GND_ANA1	Analog Ground return for VDD_ANA1 (see recommended bypass - Figure 4 on Page 6)	TBD	Not Muxed	GND_ANA1
GND_ANA2	Analog Ground (see recommended bypass - Figure 4 on Page 6)	TBD	Not Muxed	GND_ANA2
GND_ANA3	Analog Ground (see recommended bypass - Figure 4 on Page 6)	TBD	Not Muxed	GND_ANA3
GND_VREF0	Ground return for VREF0 (see recommended bypass filter- Figure 4 on Page 6)	TBD	Not Muxed	GND_VREF0
GND_VREF1	Ground return for VREF1 (see recommended bypass filter- Figure 4 on Page 6)	TBD	Not Muxed	GND_VREF1
JTG_TCK/SWCLK	JTG Clock/Serial Wire Clock	TBD	Not Muxed	JTG_TCK/SWCLK
JTG_TDI	JTG Serial Data In	TBD	Not Muxed	JTG_TDI
JTG_TDO/SWO	JTG Serial Data Out/Serial Wire Trace Output	TBD	Not Muxed	JTG_TDO/SWO
JTG_TMS/SWDIO	JTG Mode Select/Serial Wire Debug Data I/O	TBD	Not Muxed	JTG_TMS/SWDIO
JTG_TRST	JTG Reset	TBD	Not Muxed	JTG_TRST
PA_00 – PA_15	Port A Positions 0 – 15	TBD	A	PA_00 – PA_15
PB_00 – PB_15	Port B Positions 0 – 15	TBD	B	PB_00 – PB_15
PC_00 – PC_07	Port C Positions 0 – 7	TBD	C	PC_00 – PC_07
PWM0_AH	PWM0 Channel A High Side	TBD	A	PA_02
PWM0_AL	PWM0 Channel A Low Side	TBD	A	PA_03
PWM0_BH	PWM0 Channel B High Side	TBD	A	PA_04
PWM0_BL	PWM0 Channel B Low Side	TBD	A	PA_05
PWM0_CH	PWM0 Channel C High Side	TBD	A	PA_06
PWM0_CL	PWM0 Channel C Low Side	TBD	A	PA_07
PWM0_DH	PWM0 Channel D High Side	TBD	B	PB_00
PWM0_DL	PWM0 Channel D Low Side	TBD	B	PB_01
PWM0_SYNC	PWM0 Sync	TBD	A	PA_00
PWM0_TRIP0	PWM0 Shutdown Input 0	TBD	A	PA_01
PWM1_AH	PWM1 Channel A High Side	TBD	A	PA_12
PWM1_AL	PWM1 Channel A Low Side	TBD	A	PA_13
PWM1_BH	PWM1 Channel B High Side	TBD	A	PA_14
PWM1_BL	PWM1 Channel B Low Side	TBD	A	PA_15
PWM1_CH	PWM1 Channel C High Side	TBD	A	PA_08
PWM1_CL	PWM1 Channel C Low Side	TBD	A	PA_09
PWM1_DH	PWM1 Channel D High Side	TBD	B	PB_02
PWM1_DL	PWM1 Channel D Low Side	TBD	B	PB_03
PWM1_SYNC	PWM1 Sync	TBD	A	PA_10
PWM1_TRIP0	PWM1 Shutdown Input 0	TBD	A	PA_11
PWM2_AH	PWM2 Channel A High Side	TBD	B	PB_06
PWM2_AL	PWM2 Channel A Low Side	TBD	B	PB_07
PWM2_BH	PWM2 Channel B High Side	TBD	B	PB_08
PWM2_BL	PWM2 Channel B Low Side	TBD	B	PB_09
PWM2_CH	PWM2 Channel C High Side	TBD	C	PC_03
PWM2_CL	PWM2 Channel C Low Side	TBD	C	PC_04
PWM2_DH	PWM2 Channel D High Side	TBD	C	PC_05

Table 6. ADSP-CM402F/ADSP-CM403F Signal Descriptions (Continued)

Signal	Description	Driver Type	Port	Lead Name
PWM2_DL	PWM2 Channel D Low Side	TBD	C	PC_06
PWM2_SYNC	PWM2 Sync	TBD	B	PB_04
PWM2_TRIP0	PWM2 Shutdown Input 0	TBD	B	PB_05
REFCAP	Output of BandGap Generator Filter Node (see recommended bypass filter - Figure 4 on Page 6)	TBD	Not Muxed	REFCAP
SINC0_CLK0	SINC0 Clock 0	TBD	B	PB_10
SINC0_CLK1	SINC0 Clock 1	TBD	C	PC_07
SINC0_D0	SINC0 Data 0	TBD	B	PB_11
SINC0_D1	SINC0 Data 1	TBD	B	PB_12
SINC0_D2	SINC0 Data 2	TBD	B	PB_13
SINC0_D3	SINC0 Data 3	TBD	B	PB_14
SMC0_A01	SMC0 Address 1	TBD	B	PB_13
SMC0_A02	SMC0 Address 2	TBD	B	PB_14
SMC0_A03	SMC0 Address 3	TBD	B	PB_15
SMC0_A04	SMC0 Address 4	TBD	C	PC_00
SMC0_A05	SMC0 Address 5	TBD	C	PC_01
SMC0_AMS0	SMC0 Memory Select 0	TBD	B	PB_11
SMC0_AMS2	SMC0 Memory Select 2	TBD	A	PA_07
SMC0_AOE	SMC0 Output Enable	TBD	B	PB_12
SMC0_ARDY	SMC0 Asynchronous Ready	TBD	B	PB_08
SMC0_ARE	SMC0 Read Enable	TBD	B	PB_09
SMC0_AWE	SMC0 Write Enable	TBD	B	PB_10
SMC0_D00	SMC0 Data 0	TBD	A	PA_08
SMC0_D01	SMC0 Data 1	TBD	A	PA_09
SMC0_D02	SMC0 Data 2	TBD	A	PA_10
SMC0_D03	SMC0 Data 3	TBD	A	PA_11
SMC0_D04	SMC0 Data 4	TBD	A	PA_12
SMC0_D05	SMC0 Data 5	TBD	A	PA_13
SMC0_D06	SMC0 Data 6	TBD	A	PA_14
SMC0_D07	SMC0 Data 7	TBD	A	PA_15
SMC0_D08	SMC0 Data 8	TBD	B	PB_00
SMC0_D09	SMC0 Data 9	TBD	B	PB_01
SMC0_D10	SMC0 Data 10	TBD	B	PB_02
SMC0_D11	SMC0 Data 11	TBD	B	PB_03
SMC0_D12	SMC0 Data 12	TBD	B	PB_04
SMC0_D13	SMC0 Data 13	TBD	B	PB_05
SMC0_D14	SMC0 Data 14	TBD	B	PB_06
SMC0_D15	SMC0 Data 15	TBD	B	PB_07
SPIO_CLK	SPIO Clock	TBD	C	PC_03
SPIO_D2	SPIO Data 2	TBD	B	PB_10
SPIO_D3	SPIO Data 3	TBD	B	PB_11
SPIO_MISO	SPIO Master In, Slave Out	TBD	C	PC_04
SPIO_MOSI	SPIO Master Out, Slave In	TBD	C	PC_05
SPIO_RDY	SPIO Ready	TBD	C	PC_02
SPIO_SEL1	SPIO Slave Select Output 1	TBD	C	PC_06
SPIO_SEL2	SPIO Slave Select Output 2	TBD	B	PB_13

Table 6. ADSP-CM402F/ADSP-CM403F Signal Descriptions (Continued)

Signal	Description	Driver Type	Port	Lead Name
SPIO_SEL3	SPIO Slave Select Output 3	TBD	B	PB_14
SPIO_SS	SPIO Slave Select Input	TBD	B	PB_14
SPT0_ACLK	SPORT0 Channel A Clock	TBD	B	PB_00
SPT0_AD0	SPORT0 Channel A Data 0	TBD	B	PB_02
SPT0_AD1	SPORT0 Channel A Data 1	TBD	B	PB_03
SPT0_AFS	SPORT0 Channel A Frame Sync	TBD	B	PB_01
SPT0_ATDV	SPORT0 Channel A Transmit Data Valid	TBD	B	PB_04
SPT1_ACLK	SPORT1 Channel A Clock	TBD	A	PA_00
SPT1_AD0	SPORT1 Channel A Data 0	TBD	A	PA_02
SPT1_AD1	SPORT1 Channel A Data 1	TBD	A	PA_03
SPT1_AFS	SPORT1 Channel A Frame Sync	TBD	A	PA_01
SPT1_ATDV	SPORT1 Channel A Transmit Data Valid	TBD	B	PB_15
SPT1_BCLK	SPORT1 Channel B Clock	TBD	A	PA_04
SPT1_BD0	SPORT1 Channel B Data 0	TBD	A	PA_06
SPT1_BD1	SPORT1 Channel B Data 1	TBD	A	PA_07
SPT1_BFS	SPORT1 Channel B Frame Sync	TBD	A	PA_05
SPT1_BTDV	SPORT1 Channel B Transmit Data Valid	TBD	C	PC_00
SYS_BMODE0	System Boot Mode Control 0	TBD	Not Muxed	SYS_BMODE0
SYS_BMODE1	System Boot Mode Control 1	TBD	Not Muxed	SYS_BMODE1
SYS_CLKIN	System Clock/Crystal Input	TBD	Not Muxed	SYS_CLKIN
SYS_CLKOUT	System Processor Clock Output	TBD	Not Muxed	SYS_CLKOUT
SYS_DSWAKE0	System Deep Sleep Wakeup 0	TBD	C	PC_06
SYS_DSWAKE1	System Deep Sleep Wakeup 1	TBD	C	PC_07
SYS_DSWAKE2	System Deep Sleep Wakeup 2	TBD	B	PB_14
SYS_DSWAKE3	System Deep Sleep Wakeup 3	TBD	B	PB_13
SYS_FAULT	System Complementary Fault Output	TBD	Not Muxed	SYS_FAULT
SYS_HWRST	System Processor Hardware Reset Control	TBD	Not Muxed	SYS_HWRST
SYS_NMI	System Non-maskable Interrupt	TBD	Not Muxed	SYS_NMI
SYS_RESOUT	System Reset Output	TBD	Not Muxed	SYS_RESOUT
SYS_XTAL	System Crystal Output	TBD	Not Muxed	SYS_XTAL
TM0_AC11	TIMER0 Alternate Capture Input 1	TBD	B	PB_10
TM0_AC12	TIMER0 Alternate Capture Input 2	TBD	B	PB_08
TM0_AC13	TIMER0 Alternate Capture Input 3	TBD	B	PB_12
TM0_AC14	TIMER0 Alternate Capture Input 4	TBD	B	PB_15
TM0_AC15	TIMER0 Alternate Capture Input 5	TBD	C	PC_01
TM0_ACLK0	TIMER0 Alternate Clock 0	TBD	B	PB_13
TM0_ACLK1	TIMER0 Alternate Clock 1	TBD	B	PB_11
TM0_ACLK2	TIMER0 Alternate Clock 2	TBD	A	PA_11
TM0_ACLK3	TIMER0 Alternate Clock 3	TBD	A	PA_10
TM0_ACLK4	TIMER0 Alternate Clock 4	TBD	A	PA_09
TM0_ACLK5	TIMER0 Alternate Clock 5	TBD	A	PA_08
TM0_CLK	TIMER0 Clock	TBD	B	PB_06
TM0_TMR0	TIMER0 Timer 0	TBD	B	PB_07
TM0_TMR1	TIMER0 Timer 1	TBD	B	PB_08
TM0_TMR2	TIMER0 Timer 2	TBD	B	PB_09

Table 6. ADSP-CM402F/ADSP-CM403F Signal Descriptions (Continued)

Signal	Description	Driver Type	Port	Lead Name
TMO_TMR3	TIMER0 Timer 3	TBD	A	PA_15
TMO_TMR4	TIMER0 Timer 4	TBD	A	PA_12
TMO_TMR5	TIMER0 Timer 5	TBD	A	PA_13
TMO_TMR6	TIMER0 Timer 6	TBD	A	PA_14
TMO_TMR7	TIMER0 Timer 7	TBD	B	PB_05
TRACE_CLK	Embedded Trace Module Clock	TBD	B	PB_00
TRACE_D0	Embedded Trace Module Data 0	TBD	B	PB_01
TRACE_D1	Embedded Trace Module Data 1	TBD	B	PB_02
TRACE_D2	Embedded Trace Module Data 2	TBD	B	PB_03
TRACE_D3	Embedded Trace Module Data 3	TBD	C	PC_02
TWI0_SCL	TWI0 Serial Clock	TBD	Not Muxed	TWI0_SCL
TWI0_SDA	TWI0 Serial Data	TBD	Not Muxed	TWI0_SDA
UART0_CTS	UART0 Clear to Send	TBD	B	PB_05
UART0_RTS	UART0 Request to Send	TBD	B	PB_04
UART0_RX	UART0 Receive	TBD	C	PC_01
UART0_TX	UART0 Transmit	TBD	C	PC_02
UART1_CTS	UART1 Clear to Send	TBD	A	PA_11
UART1_RTS	UART1 Request to Send	TBD	C	PC_07
UART1_RX	UART1 Receive	TBD	B	PB_08
UART1_RX	UART1 Receive	TBD	B	PB_15
UART1_TX	UART1 Transmit	TBD	B	PB_09
UART1_TX	UART1 Transmit	TBD	C	PC_00
UART2_RX	UART2 Receive	TBD	B	PB_12
UART2_TX	UART2 Transmit	TBD	C	PC_07
VDD_ANA0	Analog Power Supply Voltage (see recommended bypass - Figure 4 on Page 6)	TBD	Not Muxed	VDD_ANA0
VDD_ANA1	Analog Power Supply Voltage (see recommended bypass - Figure 4 on Page 6)	TBD	Not Muxed	VDD_ANA1
VDD_EXT	External Voltage Domain	TBD	Not Muxed	VDD_EXT
VDD_INT	Internal Voltage Domain	TBD	Not Muxed	VDD_INT
VDD_VREG	VREG Supply Voltage	TBD	Not Muxed	VDD_VREG
VREF0	Voltage Reference for ADC0. Default configuration is Output (see recommended bypass - Figure 4 on Page 6)	TBD	Not Muxed	VREF0
VREF1	Voltage Reference for ADC1. Default configuration is Output (see recommended bypass - Figure 4 on Page 6)	TBD	Not Muxed	VREF1
VREG_BASE	Voltage Regulator Base Node	TBD	Not Muxed	VREG_BASE

ADSP-CM402F/ADSP-CM403F MULTIPLEXED PINS

Table 7 through Table 9 identify the signals on each multiplexed pin on the chip, one table per port. The various functions are accessed through the indicated PORT_FER register and PORT_MUX register settings for each port.

Table 7. Signal Muxing Table Port A

PORT_FER = 0	PORT_FER = 1				Input Tap
GPIO	PORT_MUX=b#00	PORT_MUX=b#01	PORT_MUX=b#10	PORT_MUX=b#11	
PA_00	PWM0_SYNC		SPT1_ACLK		
PA_01	PWM0_TRIP0		SPT1_AFS		
PA_02	PWM0_AH		SPT1_AD0		
PA_03	PWM0_AL		SPT1_AD1		
PA_04	PWM0_BH		SPT1_BCLK		
PA_05	PWM0_BL		SPT1_BFS		
PA_06	PWM0_CH		SPT1_BD0		
PA_07	PWM0_CL	SMC0_AMS2	SPT1_BD1		
PA_08	PWM1_CH		SMC0_D00		TM0_ACLK5
PA_09	PWM1_CL		SMC0_D01		TM0_ACLK4
PA_10	PWM1_SYNC		SMC0_D02		TM0_ACLK3
PA_11	PWM1_TRIP0	UART1_CTS	SMC0_D03		TM0_ACLK2
PA_12	PWM1_AH	TM0_TMR4	SMC0_D04		
PA_13	PWM1_AL	TM0_TMR5	SMC0_D05		
PA_14	PWM1_BH	TM0_TMR6	SMC0_D06		
PA_15	PWM1_BL	TM0_TMR3	SMC0_D07		

Table 8. Signal Muxing Table Port B

PORT_FER = 0	PORT_FER = 1				Input Tap
GPIO	PORT_MUX=b#00	PORT_MUX=b#01	PORT_MUX=b#10	PORT_MUX=b#11	
PB_00	PWM0_DH	TRACE_CLK	SPT0_ACLK	SMC0_D08	CNT0_ZM
PB_01	PWM0_DL	TRACE_D0	SPT0_AFS	SMC0_D09	CNT0_UD
PB_02	PWM1_DH	TRACE_D1	SPT0_AD0	SMC0_D10	CNT0_DG
PB_03	PWM1_DL	TRACE_D2	SPT0_AD1	SMC0_D11	CNT1_ZM
PB_04	PWM2_SYNC	UART0_RTS	SPT0_ATDV	SMC0_D12	CNT1_UD
PB_05	PWM2_TRIP0	UART0_CTS	TM0_TMR7	SMC0_D13	CNT1_DG
PB_06	PWM2_AH	TM0_CLK		SMC0_D14	
PB_07	PWM2_AL	TM0_TMR0		SMC0_D15	
PB_08	PWM2_BH	TM0_TMR1	UART1_RX	SMC0_ARDY	TM0_AC12
PB_09	PWM2_BL	TM0_TMR2	UART1_TX	SMC0_ARE	
PB_10	SINC0_CLK0	SPI0_D2	CAN1_RX	SMC0_AWE	TM0_AC11
PB_11	SINC0_D0	SPI0_D3	CAN1_TX	SMC0_AMS0	TM0_ACLK1
PB_12	SINC0_D1		UART2_RX	SMC0_AOE	TM0_AC13
PB_13	SINC0_D2	CNT0_OUTA	SPI0_SEL2	SMC0_A01	TM0_ACLK0/SYS_DS_WAKE3
PB_14	SINC0_D3	CNT0_OUTB	SPI0_SEL3	SMC0_A02	SPI0_SS/SYS_DS_WAKE2
PB_15	CAN0_RX	SPT1_ATDV	UART1_RX	SMC0_A03	TM0_AC14

Table 9. Signal Muxing Table Port C

PORT_FER = 0	PORT_FER = 1				Input Tap
	PORT_MUX=b#00	PORT_MUX=b#01	PORT_MUX=b#10	PORT_MUX=b#11	
PC_00	CAN0_TX	SPT1_BTDTV	UART1_TX	SMC0_A04	TM0_AC15
PC_01	UART0_RX			SMC0_A05	
PC_02	UART0_TX	TRACE_D3	SPI0_RDY		
PC_03	SPI0_CLK	PWM2_CH			
PC_04	SPI0_MISO	PWM2_CL			
PC_05	SPI0_MOSI	PWM2_DH			
PC_06	SPI0_SEL1	PWM2_DL			SYS_DSWAKE0
PC_07	SINC0_CLK1	UART2_TX	UART1_RTS		SYS_DSWAKE1

ADSP-CM407F/ADSP-CM408F SIGNAL DESCRIPTIONS

Table 10 identifies each signal on the chip, describes the signal, and lists the driver type, port, and lead name.

Table 10. ADSP-CM407F/ADSP-CM408F Signal Descriptions

Signal	Description	Driver Type	Port	Lead Name
ADC0_VIN00	Channel 0 Single-Ended Analog Input for ADC0	TBD	Not Muxed	ADC0_VIN00
ADC0_VIN01	Channel 1 Single-Ended Analog Input for ADC0	TBD	Not Muxed	ADC0_VIN01
ADC0_VIN02	Channel 2 Single-Ended Analog Input for ADC0	TBD	Not Muxed	ADC0_VIN02
ADC0_VIN03	Channel 3 Single-Ended Analog Input for ADC0	TBD	Not Muxed	ADC0_VIN03
ADC0_VIN04	Channel 4 Single-Ended Analog Input for ADC0	TBD	Not Muxed	ADC0_VIN04
ADC0_VIN05	Channel 5 Single-Ended Analog Input for ADC0	TBD	Not Muxed	ADC0_VIN05
ADC0_VIN06	Channel 6 Single-Ended Analog Input for ADC0	TBD	Not Muxed	ADC0_VIN06
ADC0_VIN07	Channel 7 Single-Ended Analog Input for ADC0	TBD	Not Muxed	ADC0_VIN07
ADC1_VIN00	Channel 0 Single-Ended Analog Input for ADC1	TBD	Not Muxed	ADC1_VIN00
ADC1_VIN01	Channel 1 Single-Ended Analog Input for ADC1	TBD	Not Muxed	ADC1_VIN01
ADC1_VIN02	Channel 2 Single-Ended Analog Input for ADC1	TBD	Not Muxed	ADC1_VIN02
ADC1_VIN03	Channel 3 Single-Ended Analog Input for ADC1	TBD	Not Muxed	ADC1_VIN03
ADC1_VIN04	Channel 4 Single-Ended Analog Input for ADC1	TBD	Not Muxed	ADC1_VIN04
ADC1_VIN05	Channel 5 Single-Ended Analog Input for ADC1	TBD	Not Muxed	ADC1_VIN05
ADC1_VIN06	Channel 6 Single-Ended Analog Input for ADC1	TBD	Not Muxed	ADC1_VIN06
ADC1_VIN07	Channel 7 Single-Ended Analog Input for ADC1	TBD	Not Muxed	ADC1_VIN07
BYP_A0	On-chip Analog Power Regulation Bypass Filter Node for ADC0 (see recommended bypass - Figure 4 on Page 6)	TBD	Not Muxed	BYP_A0
BYP_A1	On-chip Analog Power Regulation Bypass Filter Node for ADC1 (see recommended bypass - Figure 4 on Page 6)	TBD	Not Muxed	BYP_A1
BYP_D0	On-chip Digital Power Regulation Bypass Filter Node for Analog Subsystem (see recommended bypass - Figure 4 on Page 6)	TBD	Not Muxed	BYP_D0
CAN0_RX	CAN0 Receive	TBD	B	PB_15
CAN0_TX	CAN0 Transmit	TBD	C	PC_00
CAN1_RX	CAN1 Receive	TBD	B	PB_10
CAN1_TX	CAN1 Transmit	TBD	B	PB_11
CNT0_DG	CNT0 Count Down and Gate	TBD	B	PB_02
CNT0_OUTA	CNT0 Output Divider A	TBD	B	PB_13
CNT0_OUTA	CNT0 Output Divider A	TBD	F	PF_00
CNT0_OUTB	CNT0 Output Divider B	TBD	B	PB_14
CNT0_OUTB	CNT0 Output Divider B	TBD	F	PF_01
CNT0_UD	CNT0 Count Up and Direction	TBD	B	PB_01
CNT0_ZM	CNT0 Count Zero Marker	TBD	B	PB_00
CNT1_DG	CNT1 Count Down and Gate	TBD	B	PB_05
CNT1_OUTA	CNT1 Output Divider A	TBD	E	PE_14
CNT1_OUTB	CNT1 Output Divider B	TBD	E	PE_15
CNT1_UD	CNT1 Count Up and Direction	TBD	B	PB_04
CNT1_ZM	CNT1 Count Zero Marker	TBD	B	PB_03
CNT2_DG	CNT2 Count Down and Gate	TBD	E	PE_10
CNT2_UD	CNT2 Count Up and Direction	TBD	E	PE_09
CNT2_ZM	CNT2 Count Zero Marker	TBD	E	PE_08
CNT3_DG	CNT3 Count Down and Gate	TBD	E	PE_13

Table 10. ADSP-CM407F/ADSP-CM408F Signal Descriptions (Continued)

Signal	Description	Driver Type	Port	Lead Name
CNT3_UD	CNT3 Count Up and Direction	TBD	E	PE_12
CNT3_ZM	CNT3 Count Zero Marker	TBD	E	PE_11
ETH0_CRS	EMAC0 Carrier Sense/RMII Receive Data Valid	TBD	E	PE_09
ETH0_MDC	EMAC0 Management Channel Clock	TBD	E	PE_11
ETH0_MDIO	EMAC0 Management Channel Serial Data	TBD	E	PE_10
ETH0_PTPAUXIN	EMAC0 PTP Auxiliary Trigger Input	TBD	E	PE_07
ETH0_PTPCLKIN	EMAC0 PTP Clock Input	TBD	F	PF_10
ETH0_PTPPPS	EMAC0 PTP Pulse-Per-Second Output	TBD	E	PE_08
ETH0_REFCLK	EMAC0 Reference Clock	TBD	E	PE_15
ETH0_RXD0	EMAC0 Receive Data 0	TBD	F	PF_00
ETH0_RXD1	EMAC0 Receive Data 1	TBD	F	PF_01
ETH0_TXD0	EMAC0 Transmit Data 0	TBD	E	PE_12
ETH0_TXD1	EMAC0 Transmit Data 1	TBD	E	PE_13
ETH0_TXEN	EMAC0 Transmit Enable	TBD	E	PE_14
GND	Digital Ground	TBD	Not Muxed	GND
GND_ANA0	Analog Ground return for VDD_ANA0 (see recommended bypass - Figure 4 on Page 6)	TBD	Not Muxed	GND_ANA0
GND_ANA1	Analog Ground return for VDD_ANA1 (see recommended bypass - Figure 4 on Page 6)	TBD	Not Muxed	GND_ANA1
GND_ANA2	Analog Ground (see recommended bypass - Figure 4 on Page 6)	TBD	Not Muxed	GND_ANA2
GND_ANA3	Analog Ground (see recommended bypass - Figure 4 on Page 6)	TBD	Not Muxed	GND_ANA3
GND_VREF0	Ground return for VREF0 (see recommended bypass filter- Figure 4 on Page 6)	TBD	Not Muxed	GND_VREF0
GND_VREF1	Ground return for VREF1 (see recommended bypass filter- Figure 4 on Page 6)	TBD	Not Muxed	GND_VREF1
JTG_TCK/SWCLK	JTG Clock/Serial Wire Clock	TBD	Not Muxed	JTG_TCK/SWCLK
JTG_TDI	JTG Serial Data In	TBD	Not Muxed	JTG_TDI
JTG_TDO/SWO	JTG Serial Data Out/Serial Wire Trace Output	TBD	Not Muxed	JTG_TDO/SWO
JTG_TMS/SWDIO	JTG Mode Select/Serial Wire Debug Data I/O	TBD	Not Muxed	JTG_TMS/SWDIO
JTG_TRST	JTG Reset	TBD	Not Muxed	JTG_TRST
PA_00 – PA_15	Port A Positions 0 – 15	TBD	A	PA_00 – PA_15
PB_00 – PB_15	Port B Positions 0 – 15	TBD	B	PB_00 – PB_15
PC_00 – PC_15	Port C Positions 0 – 15	TBD	C	PC_00 – PC_15
PD_00 – PD_15	Port D Positions 0 – 15	TBD	D	PD_00 – PD_15
PE_00 – PE_15	Port E Positions 0 – 15	TBD	E	PE_00 – PE_15
PF_00 – PF_10	Port F Positions 0 – 10	TBD	F	PF_00 – PF_10
PWM0_AH	PWM0 Channel A High Side	TBD	A	PA_02
PWM0_AL	PWM0 Channel A Low Side	TBD	A	PA_03
PWM0_BH	PWM0 Channel B High Side	TBD	A	PA_04
PWM0_BL	PWM0 Channel B Low Side	TBD	A	PA_05
PWM0_CH	PWM0 Channel C High Side	TBD	A	PA_06
PWM0_CL	PWM0 Channel C Low Side	TBD	A	PA_07
PWM0_DH	PWM0 Channel D High Side	TBD	B	PB_00
PWM0_DL	PWM0 Channel D Low Side	TBD	B	PB_01
PWM0_SYNC	PWM0 Sync	TBD	A	PA_00
PWM0_TRIPO	PWM0 Shutdown Input 0	TBD	A	PA_01

Table 10. ADSP-CM407F/ADSP-CM408F Signal Descriptions (Continued)

Signal	Description	Driver Type	Port	Lead Name
PWM1_AH	PWM1 Channel A High Side	TBD	A	PA_12
PWM1_AL	PWM1 Channel A Low Side	TBD	A	PA_13
PWM1_BH	PWM1 Channel B High Side	TBD	A	PA_14
PWM1_BL	PWM1 Channel B Low Side	TBD	A	PA_15
PWM1_CH	PWM1 Channel C High Side	TBD	A	PA_08
PWM1_CL	PWM1 Channel C Low Side	TBD	A	PA_09
PWM1_DH	PWM1 Channel D High Side	TBD	B	PB_02
PWM1_DL	PWM1 Channel D Low Side	TBD	B	PB_03
PWM1_SYNC	PWM1 Sync	TBD	A	PA_10
<u>PWM1_TRIP0</u>	PWM1 Shutdown Input 0	TBD	A	PA_11
PWM2_AH	PWM2 Channel A High Side	TBD	B	PB_06
PWM2_AL	PWM2 Channel A Low Side	TBD	B	PB_07
PWM2_BH	PWM2 Channel B High Side	TBD	B	PB_08
PWM2_BL	PWM2 Channel B Low Side	TBD	B	PB_09
PWM2_CH	PWM2 Channel C High Side	TBD	C	PC_03
PWM2_CL	PWM2 Channel C Low Side	TBD	C	PC_04
PWM2_DH	PWM2 Channel D High Side	TBD	C	PC_05
PWM2_DL	PWM2 Channel D Low Side	TBD	C	PC_06
PWM2_SYNC	PWM2 Sync	TBD	B	PB_04
<u>PWM2_TRIP0</u>	PWM2 Shutdown Input 0	TBD	B	PB_05
REFCAP	Output of BandGap Generator Filter Node (see recommended bypass filter - Figure 4 on Page 6)	TBD	Not Muxed	REFCAP
SINC0_CLK0	SINC0 Clock 0	TBD	B	PB_10
SINC0_CLK1	SINC0 Clock 1	TBD	C	PC_07
SINC0_D0	SINC0 Data 0	TBD	B	PB_11
SINC0_D1	SINC0 Data 1	TBD	B	PB_12
SINC0_D2	SINC0 Data 2	TBD	B	PB_13
SINC0_D3	SINC0 Data 3	TBD	B	PB_14
SMC0_A01	SMC0 Address 1	TBD	B	PB_13
SMC0_A01	SMC0 Address 1	TBD	F	PF_05
SMC0_A02	SMC0 Address 2	TBD	B	PB_14
SMC0_A02	SMC0 Address 2	TBD	F	PF_06
SMC0_A03	SMC0 Address 3	TBD	B	PB_15
SMC0_A03	SMC0 Address 3	TBD	F	PF_07
SMC0_A04	SMC0 Address 4	TBD	C	PC_00
SMC0_A04	SMC0 Address 4	TBD	F	PF_08
SMC0_A05	SMC0 Address 5	TBD	C	PC_01
SMC0_A05	SMC0 Address 5	TBD	F	PF_09
SMC0_A06	SMC0 Address 6	TBD	D	PD_08
SMC0_A07	SMC0 Address 7	TBD	D	PD_09
SMC0_A08	SMC0 Address 8	TBD	D	PD_10
SMC0_A09	SMC0 Address 9	TBD	D	PD_11
SMC0_A10	SMC0 Address 10	TBD	D	PD_12
SMC0_A11	SMC0 Address 11	TBD	D	PD_13
SMC0_A12	SMC0 Address 12	TBD	D	PD_14
SMC0_A13	SMC0 Address 13	TBD	D	PD_15

Table 10. ADSP-CM407F/ADSP-CM408F Signal Descriptions (Continued)

Signal	Description	Driver Type	Port	Lead Name
SMC0_A14	SMC0 Address 14	TBD	E	PE_00
SMC0_A15	SMC0 Address 15	TBD	E	PE_01
SMC0_A16	SMC0 Address 16	TBD	E	PE_02
SMC0_A17	SMC0 Address 17	TBD	E	PE_03
SMC0_A18	SMC0 Address 18	TBD	E	PE_04
SMC0_A19	SMC0 Address 19	TBD	E	PE_05
SMC0_A20	SMC0 Address 20	TBD	E	PE_06
SMC0_A21	SMC0 Address 21	TBD	E	PE_07
SMC0_A22	SMC0 Address 22	TBD	E	PE_08
SMC0_A23	SMC0 Address 23	TBD	E	PE_09
SMC0_A24	SMC0 Address 24	TBD	E	PE_11
$\overline{\text{SMC0_ABE0}}$	SMC0 Byte Enable 0	TBD	E	PE_12
$\overline{\text{SMC0_ABE1}}$	SMC0 Byte Enable 1	TBD	E	PE_13
$\overline{\text{SMC0_AMS0}}$	SMC0 Memory Select 0	TBD	B	PB_11
$\overline{\text{SMC0_AMS0}}$	SMC0 Memory Select 0	TBD	Not Muxed	$\overline{\text{SMC0_AMS0}}$
$\overline{\text{SMC0_AMS1}}$	SMC0 Memory Select 1	TBD	E	PE_10
$\overline{\text{SMC0_AMS2}}$	SMC0 Memory Select 2	TBD	A	PA_07
$\overline{\text{SMC0_AMS3}}$	SMC0 Memory Select 3	TBD	C	PC_11
$\overline{\text{SMC0_AOE}}$	SMC0 Output Enable	TBD	B	PB_12
$\overline{\text{SMC0_AOE}}$	SMC0 Output Enable	TBD	F	PF_03
SMC0_ARDY	SMC0 Asynchronous Ready	TBD	B	PB_08
SMC0_ARDY	SMC0 Asynchronous Ready	TBD	F	PF_04
$\overline{\text{SMC0_ARE}}$	SMC0 Read Enable	TBD	B	PB_09
$\overline{\text{SMC0_ARE}}$	SMC0 Read Enable	TBD	Not Muxed	$\overline{\text{SMC0_ARE}}$
$\overline{\text{SMC0_AWE}}$	SMC0 Write Enable	TBD	B	PB_10
$\overline{\text{SMC0_AWE}}$	SMC0 Write Enable	TBD	Not Muxed	$\overline{\text{SMC0_AWE}}$
SMC0_D00	SMC0 Data 0	TBD	A	PA_08
SMC0_D00	SMC0 Data 0	TBD	C	PC_08
SMC0_D01	SMC0 Data 1	TBD	A	PA_09
SMC0_D01	SMC0 Data 1	TBD	C	PC_09
SMC0_D02	SMC0 Data 2	TBD	A	PA_10
SMC0_D02	SMC0 Data 2	TBD	C	PC_10
SMC0_D03	SMC0 Data 3	TBD	A	PA_11
SMC0_D03	SMC0 Data 3	TBD	C	PC_11
SMC0_D04	SMC0 Data 4	TBD	A	PA_12
SMC0_D04	SMC0 Data 4	TBD	C	PC_12
SMC0_D05	SMC0 Data 5	TBD	A	PA_13
SMC0_D05	SMC0 Data 5	TBD	C	PC_13
SMC0_D06	SMC0 Data 6	TBD	A	PA_14
SMC0_D06	SMC0 Data 6	TBD	C	PC_14
SMC0_D07	SMC0 Data 7	TBD	A	PA_15
SMC0_D07	SMC0 Data 7	TBD	C	PC_15
SMC0_D08	SMC0 Data 8	TBD	B	PB_00
SMC0_D08	SMC0 Data 8	TBD	D	PD_00
SMC0_D09	SMC0 Data 9	TBD	B	PB_01

Table 10. ADSP-CM407F/ADSP-CM408F Signal Descriptions (Continued)

Signal	Description	Driver Type	Port	Lead Name
SMC0_D09	SMC0 Data 9	TBD	D	PD_01
SMC0_D10	SMC0 Data 10	TBD	B	PB_02
SMC0_D10	SMC0 Data 10	TBD	D	PD_02
SMC0_D11	SMC0 Data 11	TBD	B	PB_03
SMC0_D11	SMC0 Data 11	TBD	D	PD_03
SMC0_D12	SMC0 Data 12	TBD	B	PB_04
SMC0_D12	SMC0 Data 12	TBD	D	PD_04
SMC0_D13	SMC0 Data 13	TBD	B	PB_05
SMC0_D13	SMC0 Data 13	TBD	D	PD_05
SMC0_D14	SMC0 Data 14	TBD	B	PB_06
SMC0_D14	SMC0 Data 14	TBD	D	PD_06
SMC0_D15	SMC0 Data 15	TBD	B	PB_07
SMC0_D15	SMC0 Data 15	TBD	D	PD_07
SPI0_CLK	SPI0 Clock	TBD	C	PC_03
SPI0_D2	SPI0 Data 2	TBD	B	PB_10
SPI0_D3	SPI0 Data 3	TBD	B	PB_11
SPI0_MISO	SPI0 Master In, Slave Out	TBD	C	PC_04
SPI0_MOSI	SPI0 Master Out, Slave In	TBD	C	PC_05
SPI0_RDY	SPI0 Ready	TBD	C	PC_02
$\overline{\text{SPI0_SEL1}}$	SPI0 Slave Select Output 1	TBD	C	PC_06
$\overline{\text{SPI0_SEL2}}$	SPI0 Slave Select Output 2	TBD	B	PB_13
$\overline{\text{SPI0_SEL3}}$	SPI0 Slave Select Output 3	TBD	B	PB_14
$\overline{\text{SPI0_SS}}$	SPI0 Slave Select Input	TBD	B	PB_14
SPI1_CLK	SPI1 Clock	TBD	C	PC_12
SPI1_MISO	SPI1 Master In, Slave Out	TBD	C	PC_13
SPI1_MOSI	SPI1 Master Out, Slave In	TBD	C	PC_14
$\overline{\text{SPI1_SEL1}}$	SPI1 Slave Select Output 1	TBD	C	PC_15
$\overline{\text{SPI1_SEL2}}$	SPI1 Slave Select Output 2	TBD	B	PB_06
$\overline{\text{SPI1_SEL3}}$	SPI1 Slave Select Output 3	TBD	B	PB_07
$\overline{\text{SPI1_SS}}$	SPI1 Slave Select Input	TBD	C	PC_15
SPT0_ACLK	SPORT0 Channel A Clock	TBD	B	PB_00
SPT0_AD0	SPORT0 Channel A Data 0	TBD	B	PB_02
SPT0_AD1	SPORT0 Channel A Data 1	TBD	B	PB_03
SPT0_AFS	SPORT0 Channel A Frame Sync	TBD	B	PB_01
SPT0_ATDV	SPORT0 Channel A Transmit Data Valid	TBD	B	PB_04
SPT0_BCLK	SPORT0 Channel B Clock	TBD	C	PC_08
SPT0_BD0	SPORT0 Channel B Data 0	TBD	C	PC_10
SPT0_BD1	SPORT0 Channel B Data 1	TBD	C	PC_11
SPT0_BFS	SPORT0 Channel B Frame Sync	TBD	C	PC_09
SPT0_BTDV	SPORT0 Channel B Transmit Data Valid	TBD	B	PB_12
SPT1_ACLK	SPORT1 Channel A Clock	TBD	A	PA_00
SPT1_AD0	SPORT1 Channel A Data 0	TBD	A	PA_02
SPT1_AD1	SPORT1 Channel A Data 1	TBD	A	PA_03
SPT1_AFS	SPORT1 Channel A Frame Sync	TBD	A	PA_01
SPT1_ATDV	SPORT1 Channel A Transmit Data Valid	TBD	B	PB_15

Table 10. ADSP-CM407F/ADSP-CM408F Signal Descriptions (Continued)

Signal	Description	Driver Type	Port	Lead Name
SPT1_BCLK	SPORT1 Channel B Clock	TBD	A	PA_04
SPT1_BD0	SPORT1 Channel B Data 0	TBD	A	PA_06
SPT1_BD1	SPORT1 Channel B Data 1	TBD	A	PA_07
SPT1_BFS	SPORT1 Channel B Frame Sync	TBD	A	PA_05
SPT1_BTDTV	SPORT1 Channel B Transmit Data Valid	TBD	C	PC_00
SYS_BMODE0	System Boot Mode Control 0	TBD	Not Muxed	SYS_BMODE0
SYS_BMODE1	System Boot Mode Control 1	TBD	Not Muxed	SYS_BMODE1
SYS_CLKIN	System Clock/Crystal Input	TBD	Not Muxed	SYS_CLKIN
SYS_CLKOUT	System Processor Clock Output	TBD	Not Muxed	SYS_CLKOUT
SYS_DSWAKE0	System Deep Sleep Wakeup 0	TBD	C	PC_06
SYS_DSWAKE1	System Deep Sleep Wakeup 1	TBD	C	PC_07
SYS_DSWAKE2	System Deep Sleep Wakeup 2	TBD	B	PB_14
SYS_DSWAKE3	System Deep Sleep Wakeup 3	TBD	B	PB_13
$\overline{\text{SYS_FAULT}}$	System Complementary Fault Output	TBD	Not Muxed	$\overline{\text{SYS_FAULT}}$
$\overline{\text{SYS_HWRST}}$	System Processor Hardware Reset Control	TBD	Not Muxed	$\overline{\text{SYS_HWRST}}$
$\overline{\text{SYS_NMI}}$	System Non-maskable Interrupt	TBD	Not Muxed	$\overline{\text{SYS_NMI}}$
SYS_RESOUT	System Reset Output	TBD	Not Muxed	SYS_RESOUT
SYS_XTAL	System Crystal Output	TBD	Not Muxed	SYS_XTAL
TM0_AC11	TIMER0 Alternate Capture Input 1	TBD	B	PB_10
TM0_AC12	TIMER0 Alternate Capture Input 2	TBD	B	PB_08
TM0_AC13	TIMER0 Alternate Capture Input 3	TBD	B	PB_12
TM0_AC14	TIMER0 Alternate Capture Input 4	TBD	B	PB_15
TM0_AC15	TIMER0 Alternate Capture Input 5	TBD	C	PC_01
TM0_ACLK0	TIMER0 Alternate Clock 0	TBD	B	PB_13
TM0_ACLK1	TIMER0 Alternate Clock 1	TBD	B	PB_11
TM0_ACLK2	TIMER0 Alternate Clock 2	TBD	A	PA_11
TM0_ACLK3	TIMER0 Alternate Clock 3	TBD	A	PA_10
TM0_ACLK4	TIMER0 Alternate Clock 4	TBD	A	PA_09
TM0_ACLK5	TIMER0 Alternate Clock 5	TBD	A	PA_08
TM0_CLK	TIMER0 Clock	TBD	B	PB_06
TM0_TMR0	TIMER0 Timer 0	TBD	B	PB_07
TM0_TMR1	TIMER0 Timer 1	TBD	B	PB_08
TM0_TMR2	TIMER0 Timer 2	TBD	B	PB_09
TM0_TMR3	TIMER0 Timer 3	TBD	A	PA_15
TM0_TMR4	TIMER0 Timer 4	TBD	A	PA_12
TM0_TMR5	TIMER0 Timer 5	TBD	A	PA_13
TM0_TMR6	TIMER0 Timer 6	TBD	A	PA_14
TM0_TMR7	TIMER0 Timer 7	TBD	B	PB_05
TRACE_CLK	Clock	TBD	B	PB_00
TRACE_D0	Embedded Trace Module Data 0	TBD	B	PB_01
TRACE_D1	Embedded Trace Module Data 1	TBD	B	PB_02
TRACE_D2	Embedded Trace Module Data 2	TBD	B	PB_03
TRACE_D3	Embedded Trace Module Data 3	TBD	C	PC_02
TRACE_D3	Embedded Trace Module Data 3	TBD	F	PF_02
TWI0_SCL	TWI0 Serial Clock	TBD	Not Muxed	TWI0_SCL

Table 10. ADSP-CM407F/ADSP-CM408F Signal Descriptions (Continued)

Signal	Description	Driver Type	Port	Lead Name
TWI0_SDA	TWI0 Serial Data	TBD	Not Muxed	TWI0_SDA
UART0_CTS	UART0 Clear to Send	TBD	B	PB_05
UART0_RTS	UART0 Request to Send	TBD	B	PB_04
UART0_RX	UART0 Receive	TBD	C	PC_01
UART0_TX	UART0 Transmit	TBD	C	PC_02
UART1_CTS	UART1 Clear to Send	TBD	A	PA_11
UART1_RTS	UART1 Request to Send	TBD	C	PC_07
UART1_RX	UART1 Receive	TBD	B	PB_08
UART1_RX	UART1 Receive	TBD	B	PB_15
UART1_TX	UART1 Transmit	TBD	B	PB_09
UART1_TX	UART1 Transmit	TBD	C	PC_00
UART2_RX	UART2 Receive	TBD	B	PB_12
UART2_TX	UART2 Transmit	TBD	C	PC_07
USB0_DM	USB0 Data -	TBD	Not Muxed	USB0_DM
USB0_DP	USB0 Data +	TBD	Not Muxed	USB0_DP
USB0_ID	USB0 OTG ID	TBD	Not Muxed	USB0_ID
USB0_VBC	USB0 VBUS Control	TBD	F	PF_02
USB0_VBUS	USB0 Bus Voltage	TBD	Not Muxed	USB0_VBUS
VDD_ANA0	Analog Power Supply Voltage (see recommended bypass - Figure 4 on Page 6)	TBD	Not Muxed	VDD_ANA0
VDD_ANA1	Analog Power Supply Voltage (see recommended bypass - Figure 4 on Page 6)	TBD	Not Muxed	VDD_ANA1
VDD_EXT	External Voltage Domain	TBD	Not Muxed	VDD_EXT
VDD_INT	Internal Voltage Domain	TBD	Not Muxed	VDD_INT
VDD_VREG	VREG Supply Voltage	TBD	Not Muxed	VDD_VREG
VREF0	Voltage Reference for ADC0. Default configuration is Output (see recommended bypass - Figure 4 on Page 6)	TBD	Not Muxed	VREF0
VREF1	Voltage Reference for ADC1. Default configuration is Output (see recommended bypass - Figure 4 on Page 6)	TBD	Not Muxed	VREF1
VREG_BASE	Voltage Regulator Base Node	TBD	Not Muxed	VREG_BASE

ADSP-CM407F/ADSP-CM408F MULTIPLEXED PINS

Table 11 through Table 16 identify the signals on each multiplexed pin on the chip, one table per port. The various functions are accessed through the indicated PORT_FER register and PORT_MUX register settings for each port.

Table 11. Signal Muxing Table Port A

PORT_FER = 0	PORT_FER = 1				Input Tap
	PORT_MUX=b#00	PORT_MUX=b#01	PORT_MUX=b#10	PORT_MUX=b#11	
PA_00	PWM0_SYNC		SPT1_ACLK		
PA_01	PWM0_TRIP0		SPT1_AFS		
PA_02	PWM0_AH		SPT1_AD0		
PA_03	PWM0_AL		SPT1_AD1		
PA_04	PWM0_BH		SPT1_BCLK		
PA_05	PWM0_BL		SPT1_BFS		
PA_06	PWM0_CH		SPT1_BD0		
PA_07	PWM0_CL	SMC0_AMS2	SPT1_BD1		
PA_08	PWM1_CH		SMC0_D00		TM0_ACLK5
PA_09	PWM1_CL		SMC0_D01		TM0_ACLK4
PA_10	PWM1_SYNC		SMC0_D02		TM0_ACLK3
PA_11	PWM1_TRIP0	UART1_CTS	SMC0_D03		TM0_ACLK2
PA_12	PWM1_AH	TM0_TMR4	SMC0_D04		
PA_13	PWM1_AL	TM0_TMR5	SMC0_D05		
PA_14	PWM1_BH	TM0_TMR6	SMC0_D06		
PA_15	PWM1_BL	TM0_TMR3	SMC0_D07		

Table 12. Signal Muxing Table Port B

PORT_FER = 0	PORT_FER = 1				Input Tap
	PORT_MUX=b#00	PORT_MUX=b#01	PORT_MUX=b#10	PORT_MUX=b#11	
PB_00	PWM0_DH	TRACE_CLK	SPT0_ACLK	SMC0_D08	CNT0_ZM
PB_01	PWM0_DL	TRACE_D0	SPT0_AFS	SMC0_D09	CNT0_UD
PB_02	PWM1_DH	TRACE_D1	SPT0_AD0	SMC0_D10	CNT0_DG
PB_03	PWM1_DL	TRACE_D2	SPT0_AD1	SMC0_D11	CNT1_ZM
PB_04	PWM2_SYNC	UART0_RTS	SPT0_ATDV	SMC0_D12	CNT1_UD
PB_05	PWM2_TRIP0	UART0_CTS	TM0_TMR7	SMC0_D13	CNT1_DG
PB_06	PWM2_AH	TM0_CLK	SPI1_SEL2	SMC0_D14	
PB_07	PWM2_AL	TM0_TMR0	SPI1_SEL3	SMC0_D15	
PB_08	PWM2_BH	TM0_TMR1	UART1_RX	SMC0_ARDY	TM0_AC12
PB_09	PWM2_BL	TM0_TMR2	UART1_TX	SMC0_ARE	
PB_10	SINC0_CLK0	SPIO_D2	CAN1_RX	SMC0_AWE	TM0_AC11
PB_11	SINC0_D0	SPIO_D3	CAN1_TX	SMC0_AMS0	TM0_ACLK1
PB_12	SINC0_D1	SPT0_BTDTV	UART2_RX	SMC0_AOE	TM0_AC13
PB_13	SINC0_D2	CNT0_OUTA	SPIO_SEL2	SMC0_A01	TM0_ACLK0/SYS_DSWARE3
PB_14	SINC0_D3	CNT0_OUTB	SPIO_SEL3	SMC0_A02	SPIO_SS/SYS_DSWARE2
PB_15	CAN0_RX	SPT1_ATDV	UART1_RX	SMC0_A03	TM0_AC14

Table 13. Signal Muxing Table Port C

PORT_FER = 0	PORT_FER = 1				Input Tap
	PORT_MUX=b#00	PORT_MUX=b#01	PORT_MUX=b#10	PORT_MUX=b#11	
PC_00	CAN0_TX	SPT1_BTDV	UART1_TX	SMC0_A04	TM0_ACIS SYS_DSWAKE0 SYS_DSWAKE1 SPI1_SS
PC_01	UART0_RX			SMC0_A05	
PC_02	UART0_TX	TRACE_D3	SPI0_RDY		
PC_03	SPI0_CLK	PWM2_CH			
PC_04	SPI0_MISO	PWM2_CL			
PC_05	SPI0_MOSI	PWM2_DH			
PC_06	SPI0_SEL1	PWM2_DL			
PC_07	SINC0_CLK1	UART2_TX	UART1_RTS		
PC_08		SPT0_BCLK	SMC0_D00		
PC_09		SPT0_BFS	SMC0_D01		
PC_10		SPT0_BD0	SMC0_D02		
PC_11	SMC0_AMS3	SPT0_BD1	SMC0_D03		
PC_12		SPI1_CLK	SMC0_D04		
PC_13		SPI1_MISO	SMC0_D05		
PC_14		SPI1_MOSI	SMC0_D06		
PC_15		SPI1_SEL1	SMC0_D07		

Table 14. Signal Muxing Table Port D

PORT_FER = 0	PORT_FER = 1				Input Tap
	PORT_MUX=b#00	PORT_MUX=b#01	PORT_MUX=b#10	PORT_MUX=b#11	
PD_00			SMC0_D08		
PD_01			SMC0_D09		
PD_02			SMC0_D10		
PD_03			SMC0_D11		
PD_04			SMC0_D12		
PD_05			SMC0_D13		
PD_06			SMC0_D14		
PD_07			SMC0_D15		
PD_08			SMC0_A06		
PD_09			SMC0_A07		
PD_10			SMC0_A08		
PD_11			SMC0_A09		
PD_12			SMC0_A10		
PD_13			SMC0_A11		
PD_14			SMC0_A12		
PD_15			SMC0_A13		

Table 15. Signal Muxing Table Port E

PORT_FER = 0	PORT_FER = 1				Input Tap
	PORT_MUX=b#00	PORT_MUX=b#01	PORT_MUX=b#10	PORT_MUX=b#11	
PE_00			SMC0_A14		
PE_01			SMC0_A15		
PE_02			SMC0_A16		
PE_03			SMC0_A17		
PE_04			SMC0_A18		
PE_05			SMC0_A19		
PE_06			SMC0_A20		
PE_07		ETH0_PTPAUXIN	SMC0_A21		
PE_08		ETH0_PTPPPS	SMC0_A22		CNT2_ZM
PE_09		ETH0_CRS	SMC0_A23		CNT2_UD
PE_10		ETH0_MDIO	SMC0_AMS1		CNT2_DG
PE_11	ETH0_MDC		SMC0_A24		CNT3_ZM
PE_12	ETH0_TXD0		SMC0_ABE0		CNT3_UD
PE_13	ETH0_TXD1		SMC0_ABE1		CNT3_DG
PE_14	ETH0_TXEN	CNT1_OUTA			
PE_15	ETH0_REFCLK	CNT1_OUTB			

Table 16. Signal Muxing Table Port F

PORT_FER = 0	PORT_FER = 1				Input Tap
	PORT_MUX=b#00	PORT_MUX=b#01	PORT_MUX=b#10	PORT_MUX=b#11	
PF_00	ETH0_RXD0	CNT0_OUTA			
PF_01	ETH0_RXD1	CNT0_OUTB			
PF_02	USB0_VBC	TRACE_D3			
PF_03			SMC0_AOE		
PF_04			SMC0_ARDY		
PF_05			SMC0_A01		
PF_06			SMC0_A02		
PF_07			SMC0_A03		
PF_08			SMC0_A04		
PF_09			SMC0_A05		
PF_10	ETH0_PTPCLKIN				

SPECIFICATIONS

For information about product specifications please contact your ADI representative.

OPERATING CONDITIONS

Parameter	Conditions	Min	Nominal	Max	Unit
V _{DD_INT} ¹	Digital Internal Supply Voltage	TBD MHz	TBD	TBD	V
V _{DD_EXT} ²	Digital External Supply Voltage	3.13	3.3	3.47	V
V _{DD_ANA} ²	Analog Supply Voltage	3.13	3.3	3.47	V
V _{IH} ³	High Level Input Voltage	V _{DD_EXT} = 3.47 V	2.0		V
V _{IHTWI} ⁴	High Level Input Voltage	V _{DD_EXT} = 3.47 V	0.7 × V _{BUSTWI}	V _{BUSTWI}	V
V _{IL} ³	Low Level Input Voltage	V _{DD_EXT} = 3.13 V		0.8	V
V _{ILTWI} ⁴	Low Level Input Voltage	V _{DD_EXT} = 3.13 V		0.3 × V _{BUSTWI}	V
T _J	Junction Temperature	T _{AMBIENT} = TBD°C to +TBD°C	-40	105	°C

¹ The expected nominal value is 1.2 V ±5%, and initial customer designs should design with a programmable regulator that can be adjusted from 1.0 V to 1.4 V in 50 mV steps.

² Must remain powered (even if the associated function is not used).

³ Parameter value applies to all input and bidirectional signals except TWI signals and USB0 signals.

⁴ Parameter applies to TWI_SDA and TWI_SCL.

Clock Related Operating Conditions

Table 17 describes the core clock timing requirements. The data presented in the tables applies to all speed grades except where expressly noted. Figure 8 provides a graphical representation of the various clocks and their available divider values.

Table 17. Clock Operating Conditions

Parameter	Conditions	Maximum	Unit
f _{CCLK}	Core Clock Frequency (CCLK ≥ SYSCLK, CSEL ≤ SYSSEL)	TBD	MHz
f _{SYSCLK}	SYSCLK Frequency	TBD	MHz
f _{OCLK}	Output Clock Frequency	TBD	MHz

Table 18. Phase-Locked Loop Operating Conditions

Parameter	Conditions	Minimum	Maximum	Unit
f _{PLLCLK}	PLL Clock Frequency	TBD	TBD	MHz

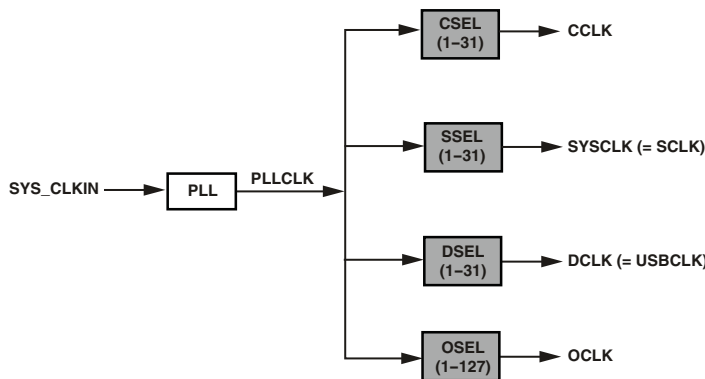

Figure 8. Clock Relationships and Divider Values

ELECTRICAL CHARACTERISTICS

Parameter	Test Conditions	Min	Typical	Max	Unit
V _{OH}	High Level Output Voltage	V _{DD_EXT} = 3.13 V, I _{OH} = -0.5 mA	2.4		V
V _{OL}	Low Level Output Voltage	V _{DD_EXT} = 3.13 V, I _{OL} = 2.0 mA		0.4	V
V _{OLTWI} ¹	Low Level Output Voltage	V _{DD_EXT} = 3.13 V, I _{OL} = 2.0 mA		TBD	V
I _{IH} ²	High Level Input Current	V _{DD_EXT} = 3.47 V, V _{IN} = 3.47 V		10	μA
I _{IL} ²	Low Level Input Current	V _{DD_EXT} = 3.47 V, V _{IN} = 0 V		10	μA
I _{IHP} ³	High Level Input Current JTAG	V _{DD_EXT} = 3.47 V, V _{IN} = 3.47 V		100	μA
I _{OZH} ⁴	Three-State Leakage Current	V _{DD_EXT} = 3.47 V, V _{IN} = 3.47 V		10	μA
I _{OZHTWI} ¹	Three-State Leakage Current	V _{DD_EXT} = 3.47 V, V _{IN} = TBD V		TBD	μA
I _{OZL} ⁴	Three-State Leakage Current	V _{DD_EXT} = 3.47 V, V _{IN} = 0 V		10	μA
C _{IN} ^{5,6}	Input Capacitance	f _{IN} = 1 MHz, T _J = 25°C, V _{IN} = 3.3 V	TBD	TBD	pF
I _{DD_DEEPSLEEP} ⁷	V _{DD_INT} Current in Deep Sleep Mode	V _{DD_INT} = TBD V, f _{CCLK} = 0 MHz, f _{SYSCLK} = 0 MHz, T _J = 25°C, ASF = 0.00	TBD		mA
I _{DD_IDLE}	V _{DD_INT} Current in Idle	V _{DD_INT} = TBD V, f _{CCLK} = TBD MHz, T _J = 25°C, ASF = TBD	TBD		mA
I _{DD_TYP}	V _{DD_INT} Current	V _{DD_INT} = TBD V, f _{CCLK} = TBD MHz, T _J = 25°C, ASF = 1.00	TBD		mA
I _{DD_DEEPSLEEP}	V _{DD_INT} Current in Deep Sleep Mode	f _{CCLK} = 0 MHz, f _{SYSCLK} = 0 MHz		TBD	mA
I _{DD_INT}	V _{DD_INT} Current	f _{CCLK} > 0 MHz, f _{SYSCLK} ≥ 0 MHz		TBD	mA

¹ Applies to bidirectional pins TWI_SCL and TWI_SDA.

² Applies to input pins.

³ Applies to JTAG input pins (JTG_TCK, JTG_TDI, JTG_TMS, JTG_TRST).

⁴ Applies to three-statable pins.

⁵ Guaranteed, but not tested.

⁶ Applies to all signal pins.

⁷ See the ADSP-CM40x Mixed-Signal Control Processor with ARM Cortex-M4 Hardware Reference for definition of deep sleep operating mode.

Total Power Dissipation

Total power dissipation has two components:

1. Static, including leakage current
2. Dynamic, due to transistor switching characteristics

Many operating conditions can also affect power dissipation, including temperature, voltage, operating frequency, and processor activity. [Electrical Characteristics on Page 35](#) shows the current dissipation for internal circuitry (V_{DD_INT}).

I_{DD_DEEPSLEEP} specifies static power dissipation as a function of voltage (V_{DD_INT}) and temperature, and I_{DD_INT} specifies the total power specification for the listed test conditions, including the dynamic component as a function of voltage (V_{DD_INT}) and frequency.

There are two parts to the dynamic component. The first part is due to transistor switching in the core clock (CCLK) domain. This part is subject to an Activity Scaling Factor (ASF) which represents application code running on the processor core and L1 memories.

The ASF is combined with the CCLK frequency and V_{DD_INT} dependent data in Table TBD to calculate this part. The second part is due to transistor switching in the system clock (SYSCLK) domain, which is included in the I_{DD_INT} specification equation (TBD).

ADC/DAC SPECIFICATIONS

ADC Specifications

Typical values assume $V_{DD_ANA} = 3.3\text{ V}$, $V_{REF} = 2.5\text{ V}$,
 $T_{JUNCTION} = 25^\circ\text{C}$ unless otherwise noted.

Parameter	Min	Typ	Max	Unit	Test Conditions/Comment
ANALOG INPUT <i>Requirement</i> Single-Ended Input Voltage Range	0		2.5	V	ADC0_V _{IN,00-11} , ADC1_V _{IN,00-11} Figure 5 on Page 6 Condition 1= Track, Figure 5 on Page 6 Condition 2 = Hold, Figure 5 on Page 6
<i>Characteristic</i> DC Leakage Current			TBD	μA	
Input Resistance		TBD		ohms	
Input Capacitance		TBD		pF	
		TBD		pF	
VOLTAGE REFERENCE (OUTPUT MODE) <i>Characteristic</i> Output Voltage		2.5 ±1.25mV		V	V _{REF0} , V _{REF1} -40°C to +105°C
Long-Term Stability		TBD		ppm	
Output Voltage Thermal Hysteresis		TBD		ppm	
Output Impedance		TBD		ohms	
Temperature Coefficient		TBD		ppm/°C	
VOLTAGE REFERENCE (INPUT MODE) <i>Requirement</i> Input Voltage Range	0		2.5	V	V _{REF0} , V _{REF1}
DC Leakage Current			TBD	μA	
Input Capacitance		TBD		pF	
STATIC PERFORMANCE DC ACCURACY <i>Characteristic</i> Resolution		16		Bits	ADC0_V _{IN,00-11} , ADC1_V _{IN,00-11} No missing codes, natural binary coding Figure 9 on Page 39 Figure 12 on Page 39
ADSP-CM403F/ADSP-CM408F Differential Non-Linearity (DNL)		-0.90/+1.5		LSB	
Integral Non-Linearity (INL)	TBD	±3.5	TBD	LSB	
Offset Error		±TBD	TBD	LSB	
Offset Error Match			TBD	LSB	
Offset Drift			TBD	LSB	
Gain Error			TBD	LSB	
Gain Error Match			TBD	LSB	
ADSP-CM402F/ADSP-CM407F Differential Non-Linearity (DNL)		-1.0/+2.0		LSB	
Integral Non-Linearity (INL)	TBD	±12.0	TBD	LSB	
Offset Error		±TBD	TBD	LSB	
Offset Error Match			TBD	LSB	
Offset Drift			TBD	LSB	
Gain Error			TBD	LSB	
Gain Error Match			TBD	LSB	

Parameter	Min	Typ	Max	Unit	Test Conditions/Comment
DYNAMIC PERFORMANCE					
Throughput					ADC0_V _{IN,00-11} , ADC1_V _{IN,00-11}
Conversion Rate			2.63	MSPS	
Acquisition time		150		nS	Figure TBD
AC ACCURACY					
<i>Characteristic</i>					
ADSP-CM403F/ADSP-CM408F					
Signal-to-Noise Ratio (SNR)		81.25		dB	f _{IN} = 1 kHz, 0 V to 2.5 V input, 2.63 MSPS
Signal-to-(Noise + Distortion) Ratio (SINAD)		81		dB	f _{IN} = 1 kHz, 0 V to 2.5 V input, 2.63 MSPS
Total Harmonic Distortion (THD)		-90		dB	f _{IN} = 1 kHz, 0 V to 2.5 V input, 2.63 MSPS
Spurious-Free Dynamic Range (SFDR)		90		dBc	f _{IN} = 1 kHz, 0 V to 2.5 V input, 2.63 MSPS
Dynamic Range		82	TBD	dB	f _{IN} = DC
Effective Number of Bits (ENOB)		13.2		Bits	
ADSP-CM402F/ADSP-CM407F					
Signal-to-Noise Ratio (SNR)		74		dB	f _{IN} = 1 kHz, 0 V to 2.5 V input, 2.63 MSPS
Signal-to-(Noise + Distortion) Ratio (SINAD)		73		dB	f _{IN} = 1 kHz, 0 V to 2.5 V input, 2.63 MSPS
Total Harmonic Distortion (THD)		-88	TBD	dB	f _{IN} = 1 kHz, 0 V to 2.5 V input, 2.63 MSPS
Spurious-Free Dynamic Range (SFDR)		88	TBD	dBc	f _{IN} = 1 kHz, 0 V to 2.5 V input, 2.63 MSPS
Dynamic Range		75.5	TBD	dB	f _{IN} = DC
Effective Number of Bits (ENOB)	TBD	11.8		Bits	
Channel-to-Channel Isolation		TBD		dB	Any Channel pair Referenced on Same ADC
ADC-to-ADC Isolation		TBD		dB	Any Channel pair Referenced on Opposite ADC
PSRR		TBD		dB	100 mv p-p @1 kHz applied to V _{DD,ANA}

DAC Specifications

Typical values assume $V_{DD_ANA} = 3.3\text{ V}$, $V_{REF} = 2.5\text{ V}$,
 $T_{JUNCTION} = 25^{\circ}\text{C}$ unless otherwise noted.

Parameter	Min	Typ	Max	Unit	Test Condition
ANALOG OUTPUT					DAC0_VOUT,DAC1_VOUT
<i>Characteristic</i>					
Output Voltage Range	TBD	0.1 to 2.5	TBD	V	
Output Impedance		TBD		Ohms	Normal operation
				Ohms	DAC @ full scale
				Ohms	DAC @ zero scale
Update Rate			50	kHz	
Short Circuit Current to GND		30		mA	
Short Circuit Current to V_{DD}		30		mA	
STATIC PERFORMANCE					
DC ACCURACY					RL = 500 ohms, CL = 100 pF
<i>Characteristic</i>					
Resolution		12		Bits	
Differential Non-Linearity (DNL)		± 0.5	TBD	LSB	Guaranteed monotonic
Integral Non-Linearity (INL)		± 2	TBD	LSB	
Offset Error		\pm TBD	TBD	mV	Measured at code TBD, Figure 23 on Page 41 , Figure 27 on Page 42
Full-Scale Error		\pm TBD	TBD	% FSR	% of full scale, measured at code 0xFF, Figure 28 on Page 42 , Figure 30 on Page 42
Gain Error		\pm TBD	TBD	% FSR	% of full scale, Figure 28 on Page 42 , Figure 30 on Page 42
DC Isolation			TBD	uV	Static output of DAC0_VOUT while DAC1_VOUT toggles 0 to full scale
DYNAMIC PERFORMANCE					
AC ACCURACY					RL = 500 ohms, CL = 100 pF
<i>Characteristic</i>					
Signal-to-Noise Ratio (SNR)		70		dB	
Signal-to-(Noise + Distortion) Ratio (SINAD)		69		dB	
Total Harmonic Distortion		TBD		dB	
Dynamic Range		TBD		dB	
Settling Time	10	TBD		μ Sec	From $\frac{1}{4}$ to $\frac{3}{4}$ full scale, Figure 31 on Page 42
Slew Rate		1.5		V/ μ Sec	
D/A Glitch Energy		TBD		nV/Sec	Measured when code changes from 0x7FF to 0x800
DAC to DAC Isolation		TBD		nV/Sec	
PSRR		TBD		dB	100mv p-p @1kHz applied to V_{DD_ANAX}

ADC Typical Performance Characteristics

$V_{DD_ANA} = 3.3\text{ V}$, $V_{REF} = 2.5\text{ V}$, $T_{JUNCTION} = 25^{\circ}\text{C}$ unless otherwise noted.

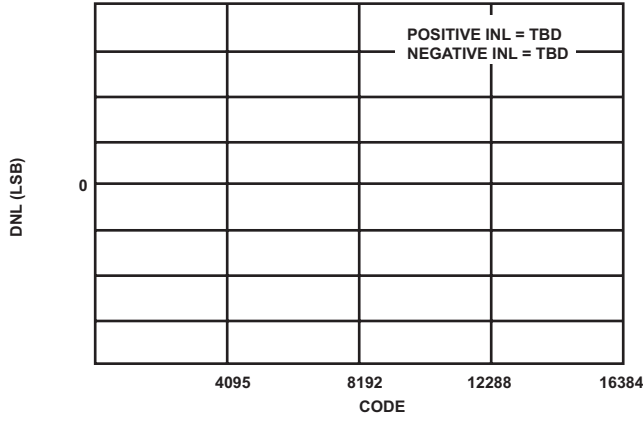

Figure 9. DNL vs. Code

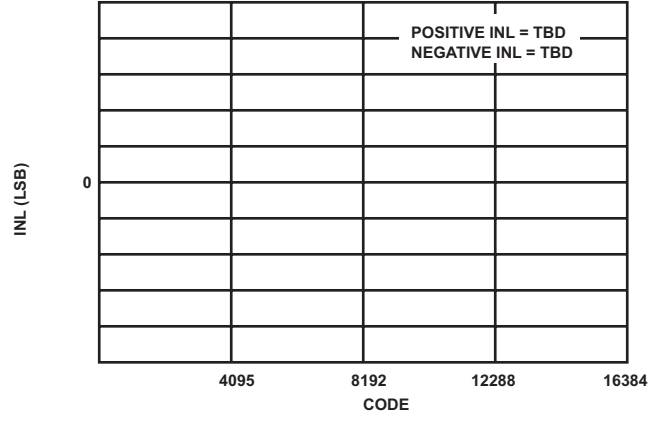

Figure 12. INL vs. Code

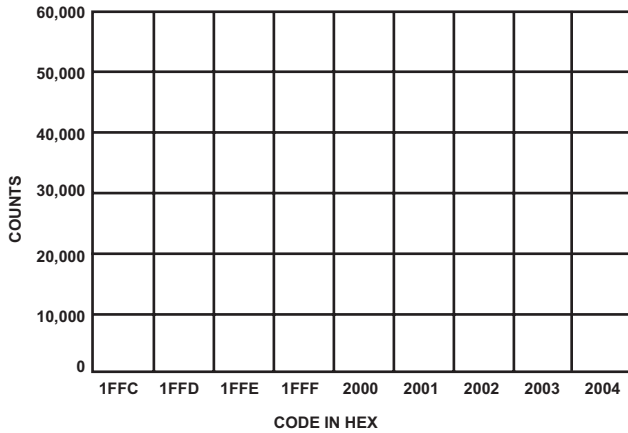

Figure 10. Histogram of DC Input at Code Center (External Reference)

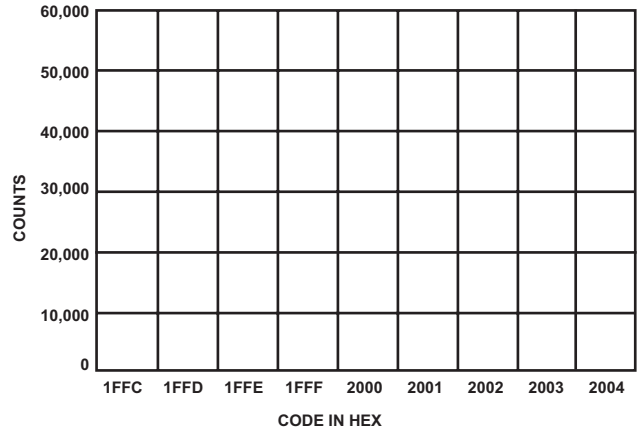

Figure 13. Histogram of DC Input at Code Transition (External Reference)

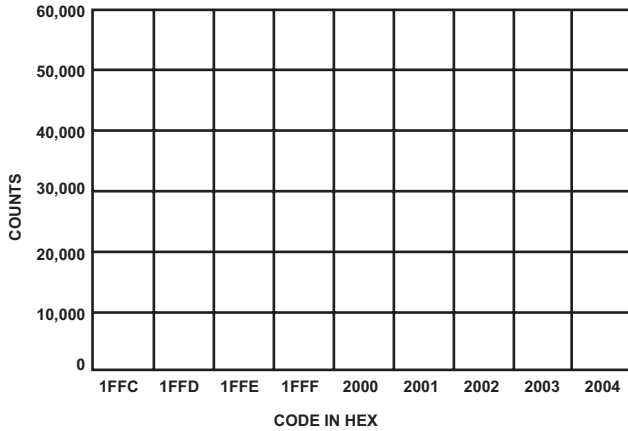

Figure 11. Histogram of DC Input at Code Center (Internal Reference)

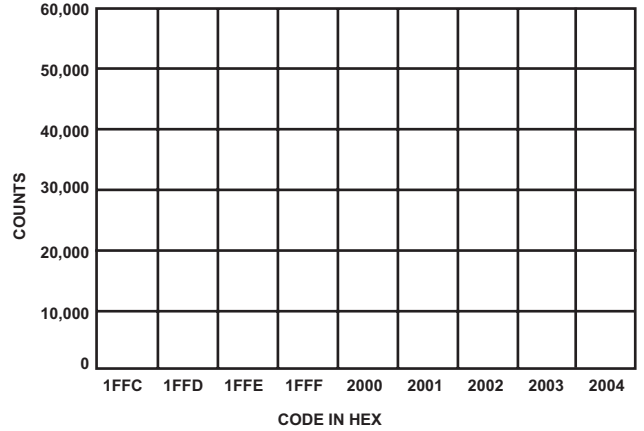

Figure 14. Histogram of DC Input at Code Transition (Internal Reference)

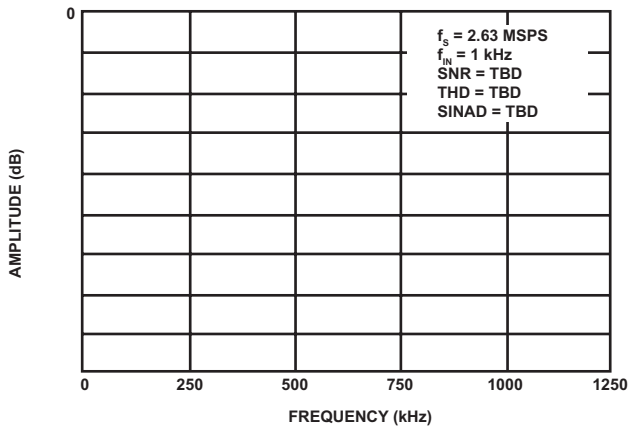

Figure 15. FFT Plot (External Reference)

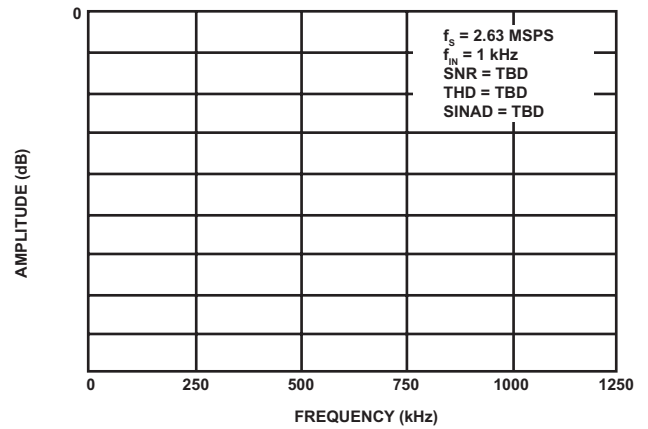

Figure 18. FFT Plot (Internal Reference)

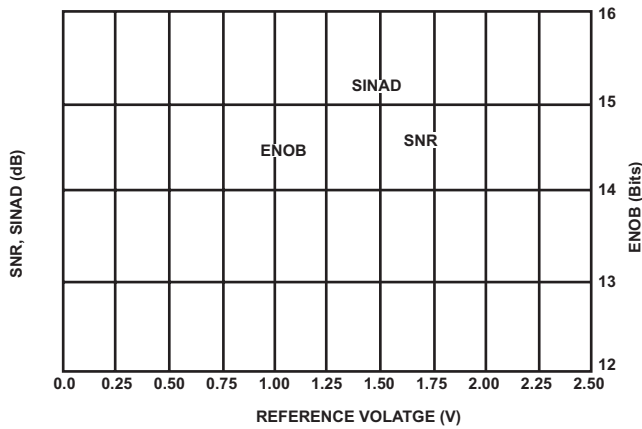

Figure 16. SNR, SINAD, and ENOB vs. External Reference Voltage

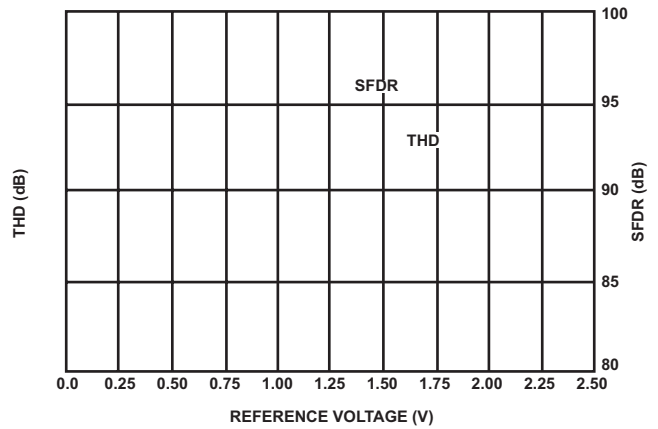

Figure 19. THD and SFDR vs. External Reference Voltage

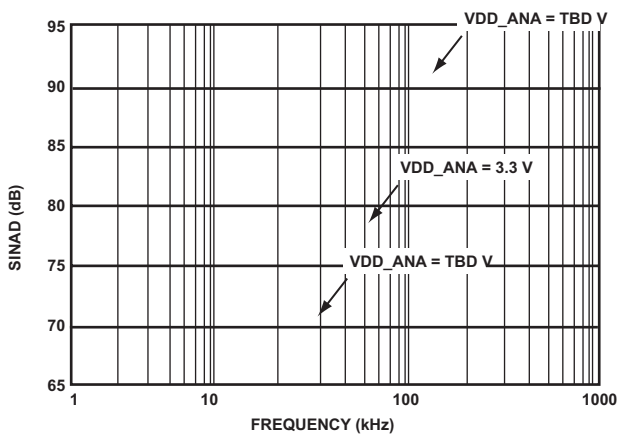

Figure 17. SINAD vs. Frequency

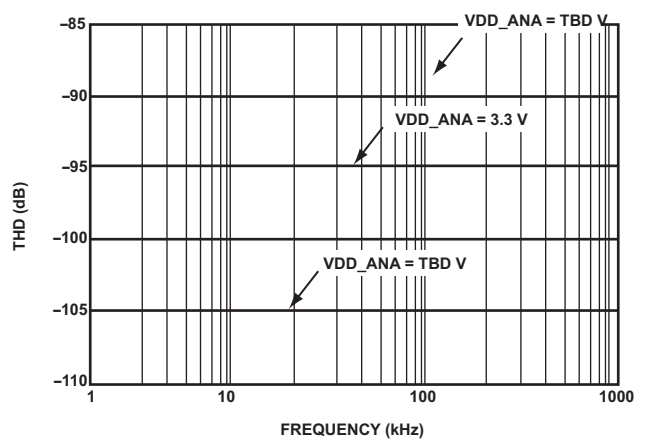

Figure 20. THD vs. Frequency

DAC Typical Performance Characteristics

$V_{DD_ANA} = 3.3\text{ V}$, $V_{REF} = 2.5\text{ V}$, $T_{JUNCTION} = 25^\circ\text{C}$ unless otherwise noted.

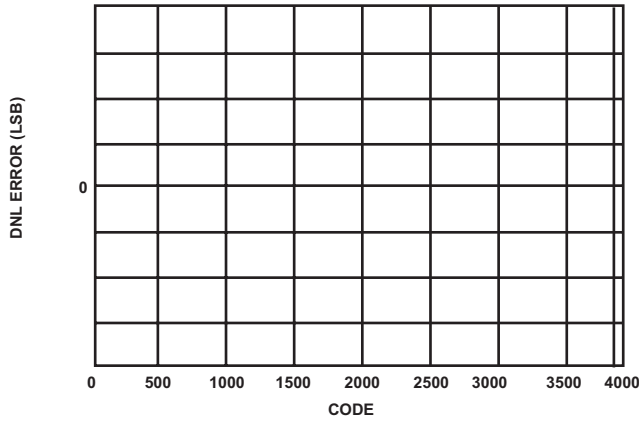

Figure 21. DNL vs. Code

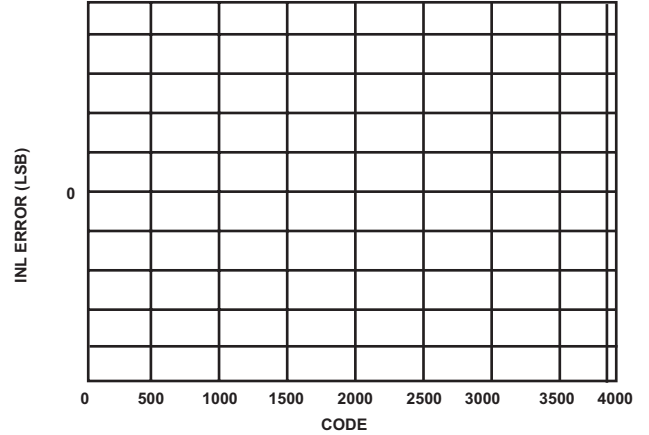

Figure 24. INL vs. Code

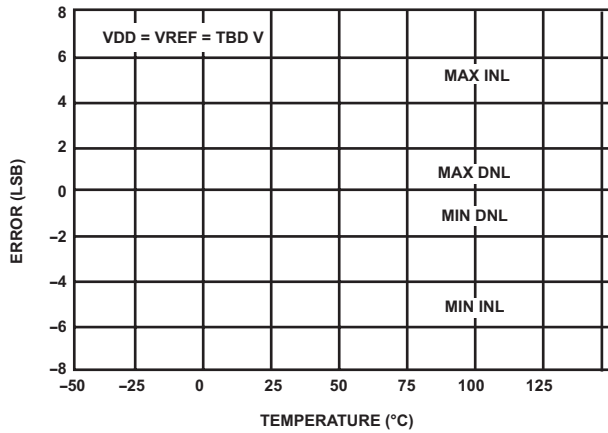

Figure 22. INL Error and DNL Error vs. Temperature

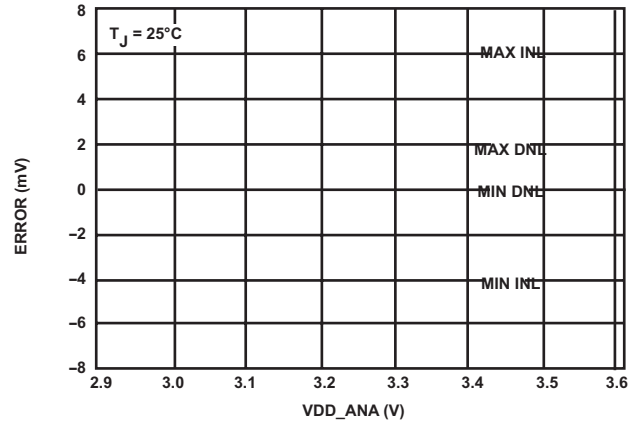

Figure 25. INL Error and DNL Error vs. Supply

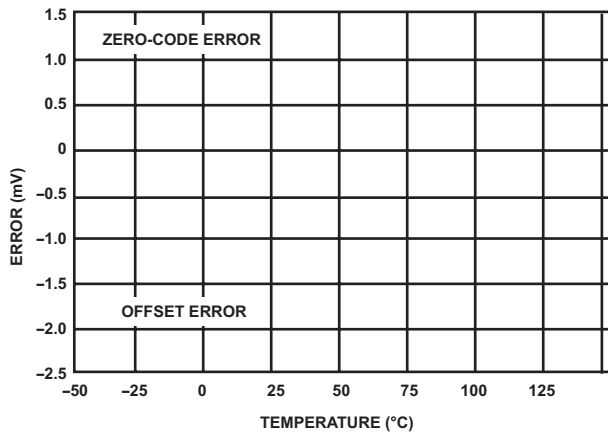

Figure 23. Zero-Code Error and Offset Error vs. Temperature

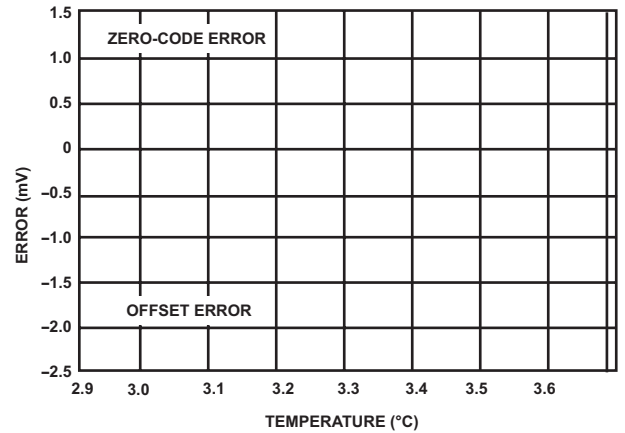

Figure 26. INL Error and DNL Error vs. Supply

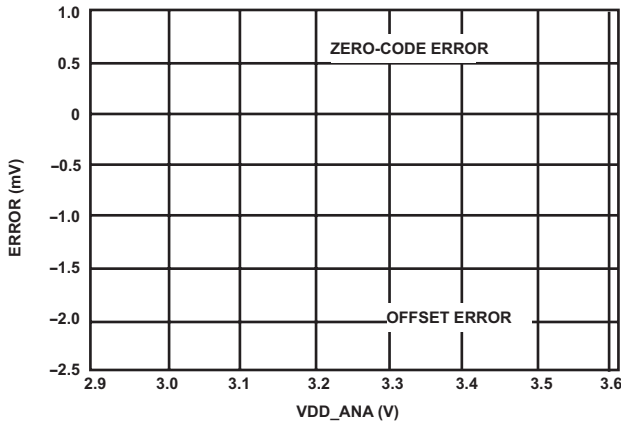

Figure 27. Zero-Code Error and Offset Error vs. Supply

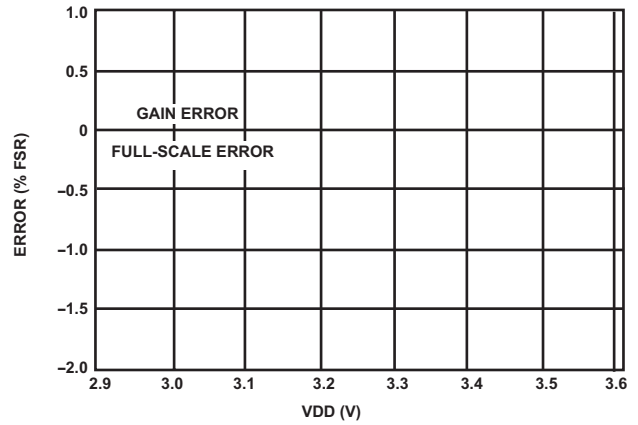

Figure 30. Gain Error and Full-Scale Error vs. Supply

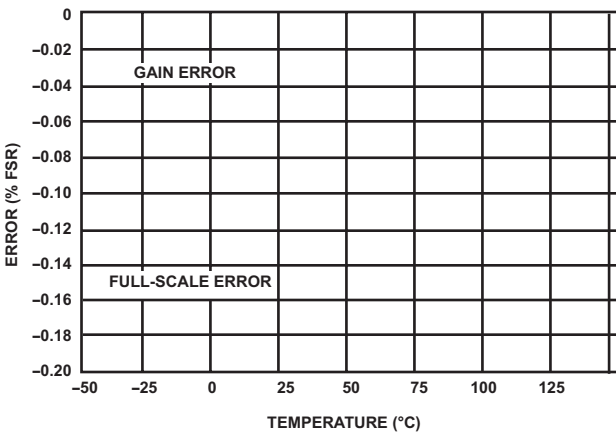

Figure 28. Gain Error and Full-Scale Error vs. Temperature

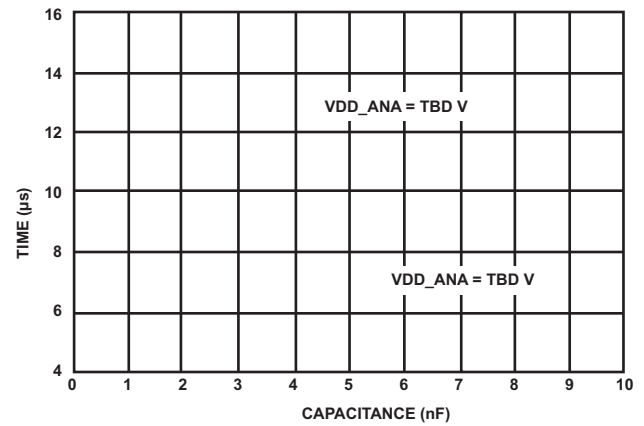

Figure 31. Settling Time vs. Capacitive Load

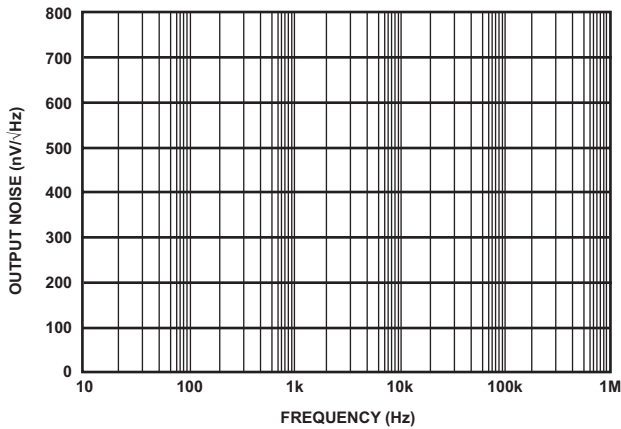

Figure 29. Noise Spectral Density

FLASH SPECIFICATIONS

The Flash features include:

- 100,000 ERASE cycles per sector
- 20 years data retention

Flash PROGRAM/ERASE SUSPEND Command

Table 19 lists parameters for the Flash suspend command.

Table 19. Suspend Parameters^{1,2,3}

Parameter	Condition	Typ	Max	Units	Notes
Erase to suspend	Sector erase or erase resume to erase suspend	700	–	μs	1
Program to suspend	Program resume to program suspend	5	–	μs	1
Subsector erase to suspend	Subsector erase or subsector erase resume to erase suspend	50	–	μs	1
Suspend latency	Program	7	–	μs	2
Suspend latency	Subsector erase	15	–	μs	2
Suspend latency	Erase	15	–	μs	3

¹Timing is not internally controlled.

²Any READ command accepted.

³Any command except the following are accepted: SECTOR, SUBSECTOR, or BULK ERASE; WRITE STATUS REGISTER.

Flash AC Characteristics and Operating Conditions

Table 20 identifies Flash specific operating conditions.

Table 20. AC Characteristics and Operating Conditions

Parameter	Symbol	Min	Typ ¹	Max	Unit
Clock frequency for all commands other than READ (SPI-ER, QIO-SPI protocol)	f _C	DC	–	100	MHz
Clock frequency for READ commands	f _R	DC	–	54	MHz
PAGE PROGRAM cycle time (256 bytes) ²	t _{PP}	–	0.5	5	ms
PAGE PROGRAM cycle time (n bytes) ^{2,3}	t _{PP}	–	int(n/8) × 0.015	5	ms
Subsector ERASE cycle time	t _{SSE}	–	0.3	1.5	s
Sector ERASE cycle time	t _{SE}	–	0.7	3	s
Bulk ERASE cycle time	t _{BE}	–	170	250	s

¹Typical values given for T_J = 25°C.

²When using the PAGE PROGRAM command to program consecutive bytes, optimized timings are obtained with one sequence including all the bytes versus several sequences of only a few bytes (1 < n < 256).

³int(A) corresponds to the upper integer part of A. For example int(12/8) = 2, int(32/8) = 4 int(15.3) =16.

ABSOLUTE MAXIMUM RATINGS

Stresses greater than those listed in the table may cause permanent damage to the device. These are stress ratings only. Functional operation of the device at these or any other conditions greater than those indicated in the operational sections of this specification is not implied. Exposure to absolute maximum rating conditions for extended periods may affect device reliability.

Parameter	Rating
Internal Supply Voltage (V_{DD_INT})	-0.33 V to +1.32 V
External (I/O) Supply Voltage (V_{DD_EXT})	-0.33 V to +3.63 V
Analog Supply Voltage (V_{DD_ANA})	-0.33 V to +3.63 V
Digital Input Voltage ^{1,2}	-0.33 V to +3.63 V
TWI Digital Input Voltage ^{1,2,3}	-0.33 V to +5.50 V
Digital Output Voltage Swing	-0.33 V to $V_{DD_EXT} + 0.5$ V
Analog Input Voltage	-0.3 V to $V_{REF0}/V_{REF1} + 0.3$ V
USB0_Dx Input	-0.33 V to +5.25 V
USB0_VBUS Input Voltage	-0.33 V to +6.00 V
Storage Temperature Range	-65°C to +150°C
Junction Temperature Under Bias	+125°C

¹ Applies to 100% transient duty cycle. For other duty cycles see Table 21.
² Applies only when V_{DD_EXT} is within specifications. When V_{DD_EXT} is outside specifications, the range is $V_{DD_EXT} \pm 0.2$ Volts.
³ Applies to pins TWI_SCL and TWI_SDA.

Table 21. Maximum Duty Cycle for Input Transient Voltage¹

V_{IN} Min (V)	V_{IN} Max (V)	Maximum Duty Cycle
TBD	TBD	TBD
TBD	TBD	TBD
TBD	TBD	TBD
TBD	TBD	TBD
TBD	TBD	TBD

¹ Applies to all signal pins with the exception of SYS_CLKIN, SYS_XTAL.

ESD SENSITIVITY



ESD (electrostatic discharge) sensitive device. Charged devices and circuit boards can discharge without detection. Although this product features patented or proprietary protection circuitry, damage may occur on devices subjected to high energy ESD. Therefore, proper ESD precautions should be taken to avoid performance degradation or loss of functionality.

PACKAGE INFORMATION

The information presented in Figure 32 and Table 22 provides details about package branding. For a complete listing of product availability, see Pre-Release Products on Page 82.



Figure 32. Product Information on Package

Table 22. Package Brand Information

Brand Key	Field Description
ADSP-CM40x	Product Name ¹
t	Temperature Range
pp	Package Type
Z	RoHS Compliant Designation
ccc	See Ordering Guide
vvvvvv.x	Assembly Lot Code
n.n	Silicon Revision
yyww	Date Code

¹ See available products in Pre-Release Products on Page 82.

TIMING SPECIFICATIONS

Specifications are subject to change without notice.

Clock and Reset Timing

Table 23 and Figure 33 describe clock and reset operations. Per the CCLK, SYSCLK, SCLK, DCLK, and OCLK timing specifications in Table 17 on Page 34, combinations of SYS_CLKIN and clock multipliers must not select clock rates in excess of the processor’s maximum instruction rate.

Table 23. Clock and Reset Timing

Parameter		Min	Max	Unit
<i>Timing Requirements</i>				
f_{CKIN}	SYS_CLKIN Frequency (using a crystal) ^{1, 2, 3}	20	50	MHz
f_{CKIN}	SYS_CLKIN Frequency (using a crystal oscillator) ^{1, 2, 3}	20	60	MHz
t_{CKINL}	SYS_CLKIN Low Pulse ¹	TBD		ns
t_{CKINH}	SYS_CLKIN High Pulse ¹	TBD		ns
t_{WRST}	$\overline{SYS_HWRST}$ Asserted Pulse Width Low ⁴	$11 \times t_{CKIN}$		ns

¹ Applies to PLL bypass mode and PLL non bypass mode.

² The t_{CKIN} period (see Figure 33) equals $1/f_{CKIN}$.

³ If the CGU_CTL.DF bit is set, the minimum f_{CKIN} specification is 40 MHz.

⁴ Applies after power-up sequence is complete. See Table 24 and Figure 34 for power-up reset timing.

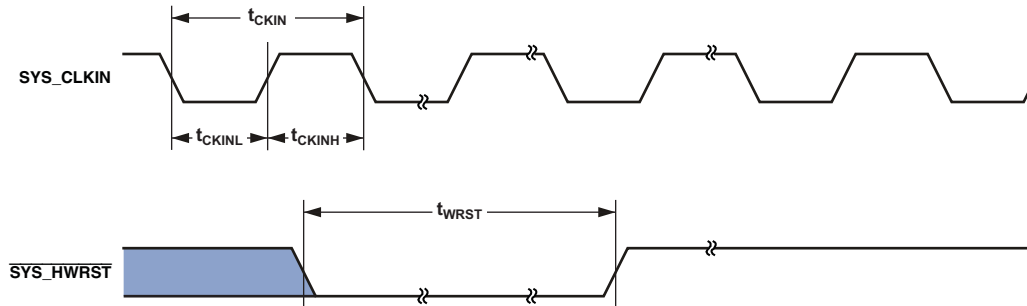

Figure 33. Clock and Reset Timing

Power-Up Reset Timing

In Figure 34, $V_{DD_SUPPLIES}$ are V_{DD_INT} , V_{DD_EXT} , V_{DD_VREG} , V_{DD_ANA0} , and V_{DD_ANA1} .

Table 24. Power-Up Reset Timing

Parameter	Min	Max	Unit
<i>Timing Requirement</i>			
$t_{RST_IN_PWR}$ $\overline{SYS_HWRST}$ Deasserted after V_{DD_INT} , V_{DD_EXT} , V_{DD_VREG} , V_{DD_ANA0} , V_{DD_ANA1} , and SYS_CLKIN are Stable and Within Specification	$11 \times t_{CKIN}$		ns

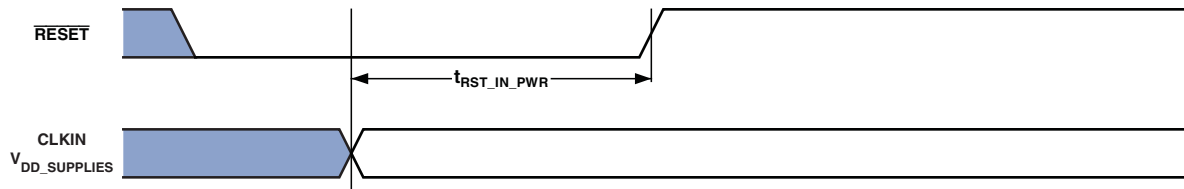

Figure 34. Power-Up Reset Timing

Asynchronous Read

Table 25. Asynchronous Memory Read (BxMODE = b#00)

Parameter	Min	Max	Unit
<i>Timing Requirements</i>			
$t_{SDATARE}$ DATA in Setup Before $\overline{SMC0_ARE}$ High	TBD		ns
$t_{HDATARE}$ DATA in Hold After $\overline{SMC0_ARE}$ High	TBD		ns
$t_{DARDYARE}$ $\overline{SMC0_ARDY}$ Valid After $\overline{SMC0_ARE}$ Low ^{1, 2}		$(RAT - 2.5) \times t_{SCLK} - TBD$	ns
<i>Switching Characteristics</i>			
$t_{ADDRARE}$ $\overline{SMC0_Ax}/\overline{SMC0_AMSx}$ Assertion Before $\overline{SMC0_ARE}$ Low ³	$(PREST + RST + PREAT) \times t_{SCLK} - TBD$		ns
t_{AOEARE} $\overline{SMC0_AOE}$ Assertion Before $\overline{SMC0_ARE}$ Low	$(RST + PREAT) \times t_{SCLK} - TBD$		ns
t_{HARE} Output ⁴ Hold After $\overline{SMC0_ARE}$ High ⁵	$RHT \times t_{SCLK} - TBD$		ns
t_{WARE} $\overline{SMC0_ARE}$ Active Low Width ⁶	$RAT \times t_{SCLK} - TBD$		ns
$t_{DAREARDY}$ $\overline{SMC0_ARE}$ High Delay After $\overline{SMC0_ARDY}$ Assertion ¹	$2.5 \times t_{SCLK}$	$3.5 \times t_{SCLK} + TBD$	ns

¹ SMC0_BxCTL.ARDYEN bit = 1.

² RAT value set using the SMC_BxTIM.RAT bits.

³ PREST, RST, and PREAT values set using the SMC_BxETIM.PREST bits, SMC_BxTIM.RST bits, and the SMC_BxETIM.PREAT bits.

⁴ Output signals are $\overline{SMC0_Ax}$, $\overline{SMC0_AMS}$, $\overline{SMC0_AOE}$, $\overline{SMC0_ABEx}$.

⁵ RHT value set using the SMC_BxTIM.RHT bits.

⁶ SMC0_BxCTL.ARDYEN bit = 0.

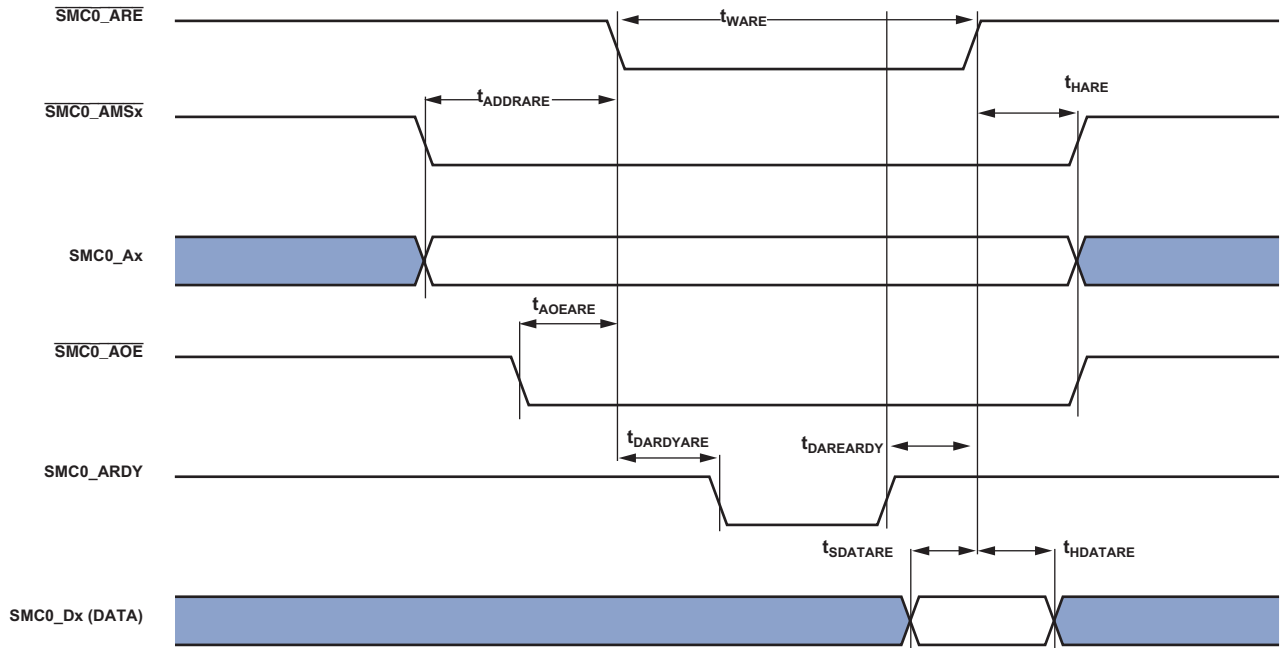

Figure 35. Asynchronous Read

Asynchronous Flash Read

Table 26. Asynchronous Flash Read

Parameter	Min	Max	Unit
<i>Switching Characteristics</i>			
t_{AMSADV} SMC0_Ax (Address)/SMC0_AMSx Assertion Before SMC0_AOE Low ¹	$PREST \times t_{SCLK} - TBD$		ns
t_{WADV} SMC0_AOE Active Low Width ²	$RST \times t_{SCLK} - TBD$		ns
$t_{DADVARE}$ SMC0_ARE Low Delay From SMC0_AOE High ³	$PREAT \times t_{SCLK} - TBD$		ns
t_{HARE} Output ⁴ Hold After SMC0_ARE High ⁵	$RHT \times t_{SCLK} - TBD$		ns
t_{WARE} ⁶ SMC0_ARE Active Low Width ⁷	$RAT \times t_{SCLK} - TBD$		ns

¹ PREST value set using the SMC_BxETIM.PREST bits.

² RST value set using the SMC_BxTIM.RST bits.

³ PREAT value set using the SMC_BxETIM.PREAT bits.

⁴ Output signals are SMC0_Ax, SMC0_AMS, SMC0_AOE.

⁵ RHT value set using the SMC_BxTIM.RHT bits.

⁶ SMC0_BxCTL.ARDYEN bit = 0.

⁷ RAT value set using the SMC_BxTIM.RAT bits.

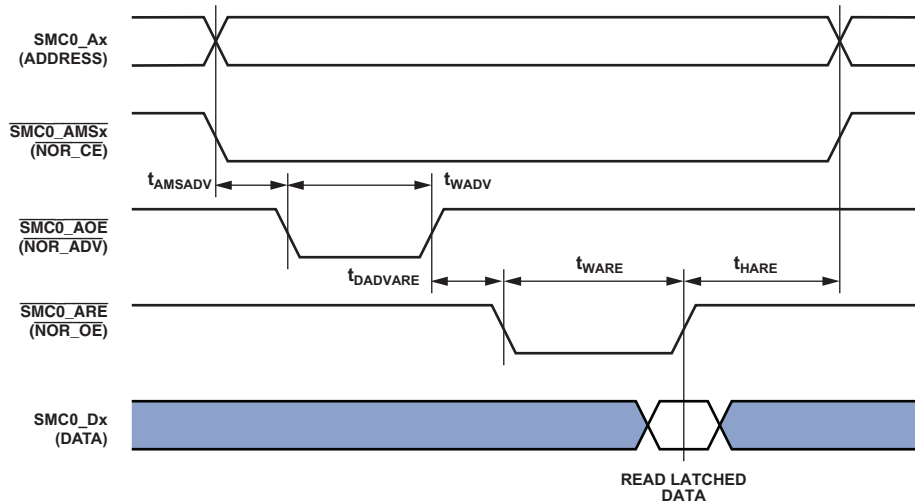

Figure 36. Asynchronous Flash Read

Asynchronous Page Mode Read

Table 27. Asynchronous Page Mode Read

Parameter	Min	Max	Unit
<i>Switching Characteristics</i>			
t_{AV} SMC0_Ax (Address) Valid for First Address Min Width ¹	$(PREST + RST + PREAT + RAT) \times t_{SCLK} - TBD$		ns
t_{AV1} SMC0_Ax (Address) Valid for Subsequent SMC0_Ax (Address) Min Width	$PGWS \times t_{SCLK} - TBD$		ns
t_{WADV} $\overline{SMC0_AOE}$ Active Low Width ²	$RST \times t_{SCLK} - TBD$		ns
t_{HARE} Output ³ Hold After $\overline{SMC0_ARE}$ High ⁴	$RHT \times t_{SCLK} - TBD$		ns
t_{WARE} ⁵ $\overline{SMC0_ARE}$ Active Low Width ⁶	$RAT \times t_{SCLK} - TBD$		ns

¹ PREST, RST, PREAT and RAT values set using the SMC_BxETIM.PREST bits, SMC_BxTIM.RST bits, SMC_BxETIM.PREAT bits, and the SMC_BxTIM.RAT bits.

² RST value set using the SMC_BxTIM.RST bits.

³ Output signals are SMC0_Ax, SMC0_AMSx, $\overline{SMC0_AOE}$.

⁴ RHT value set using the SMC_BxTIM.RHT bits.

⁵ SMC_BxCTL.ARDYEN bit = 0.

⁶ RAT value set using the SMC_BxTIM.RAT bits.

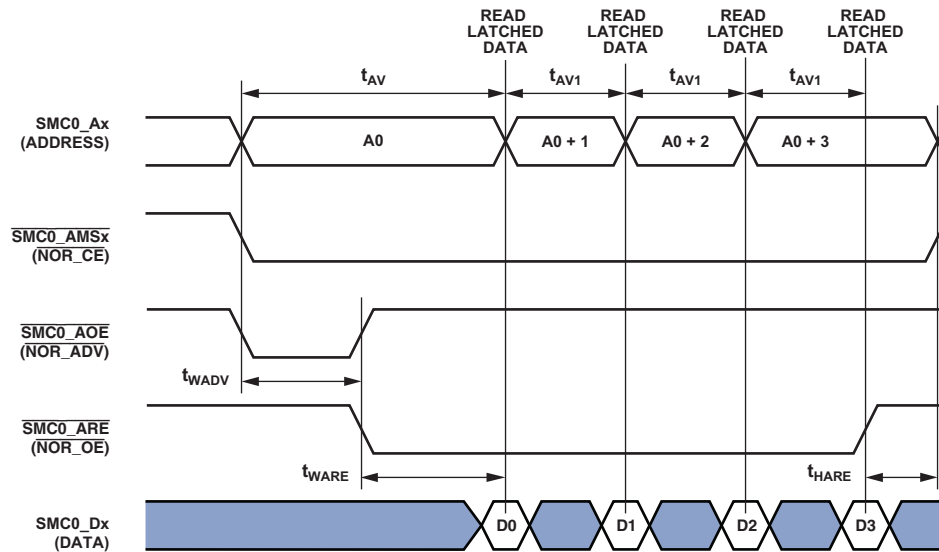

Figure 37. Asynchronous Page Mode Read

Asynchronous Write

Table 28. Asynchronous Memory Write (BxMODE = b#00)

Parameter	Min	Max	Unit
<i>Timing Requirement</i>			
$t_{DARDYAVE}^1$ SMC0_ARDY Valid After $\overline{SMC0_AWE}$ Low ²		$(WAT - 2.5) \times t_{SCLK}$ - TBD	ns
<i>Switching Characteristics</i>			
t_{ENDAT} DATA Enable After $\overline{SMC0_AMSx}$ Assertion	TBD		ns
t_{DDAT} DATA Disable After $\overline{SMC0_AMSx}$ Deassertion		TBD	ns
t_{AMSAWE} SMC0_Ax/ $\overline{SMC0_AMSx}$ Assertion Before $\overline{SMC0_AWE}$ Low ³	$(PREST + WST + PREAT) \times t_{SCLK} - TBD$		ns
t_{HAWE} Output ⁴ Hold After $\overline{SMC0_AWE}$ High ⁵	$WHT \times t_{SCLK} - TBD$		ns
t_{WAVE}^6 $\overline{SMC0_AWE}$ Active Low Width ²	$WAT \times t_{SCLK} - TBD$		ns
$t_{DAWEARDY}^1$ $\overline{SMC0_AWE}$ High Delay After SMC0_ARDY Assertion	$2.5 \times t_{SCLK}$	$3.5 \times t_{SCLK} + TBD$	ns

¹ SMC_BxCTL.ARDYEN bit = 1.

² WAT value set using the SMC_BxTIM.WAT bits.

³ PREST, WST, PREAT values set using the SMC_BxETIM.PREST bits, SMC_BxTIM.WST bits, SMC_BxETIM.PREAT bits, and the SMC_BxTIM.RAT bits.

⁴ Output signals are DATA, SMC0_Ax, $\overline{SMC0_AMSx}$, $\overline{SMC0_ABEx}$.

⁵ WHT value set using the SMC_BxTIM.WHT bits.

⁶ SMC_BxCTL.ARDYEN bit = 0.

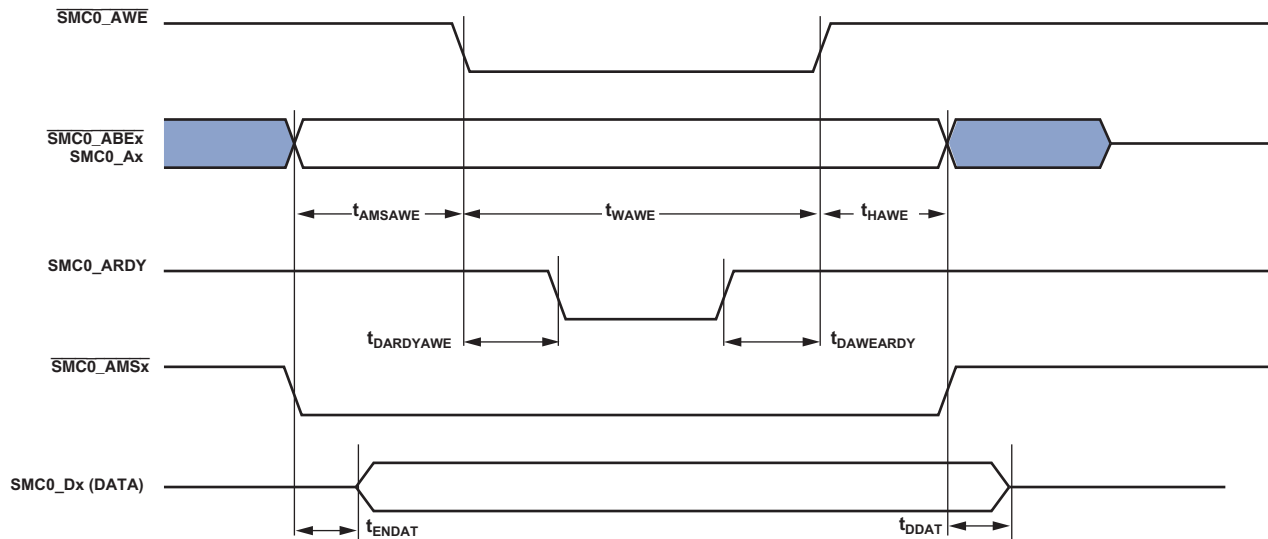

Figure 38. Asynchronous Write

Asynchronous Flash Write

Table 29. Asynchronous Flash Write

Parameter	Min	Max	Unit
<i>Switching Characteristics</i>			
t_{AMSADV} SMC0_Ax/ $\overline{SMC0_AMSx}$ Assertion Before $\overline{SMC0_AOE}$ Low ¹	PREST × t_{SCLK} – TBD		ns
$t_{DADVAVE}$ $\overline{SMC0_AVE}$ Low Delay From $\overline{SMC0_AOE}$ High ²	PREAT × t_{SCLK} – TBD		ns
t_{WADV} $\overline{SMC0_AOE}$ Active Low Width ³	WST × t_{SCLK} – TBD		ns
t_{HAVE} Output ⁴ Hold After $\overline{SMC0_AVE}$ High ⁵	WHT × t_{SCLK} – TBD		ns
t_{WAVE} ⁶ $\overline{SMC0_AVE}$ Active Low Width ⁷	WAT × t_{SCLK} – TBD		ns

¹ PREST value set using the SMC_BxETIM.PREST bits.
² PREAT value set using the SMC_BxETIM.PREAT bits.
³ WST value set using the SMC_BxTIM.WST bits.
⁴ Output signals are DATA, SMC0_Ax, $\overline{SMC0_AMSx}$, $\overline{SMC0_ABEx}$.
⁵ WHT value set using the SMC_BxTIM.WHT bits.
⁶ SMC_BxCTL.ARDYEN bit = 0.
⁷ WAT value set using the SMC_BxTIM.WAT bits.

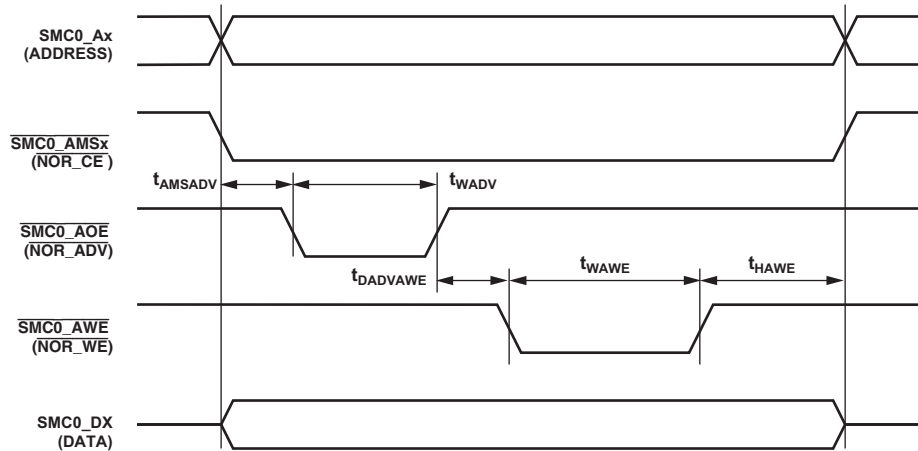

Figure 39. Asynchronous Flash Write

All Accesses

Table 30. All Accesses

Parameter	Min	Max	Unit
<i>Switching Characteristic</i>			
t_{TURN} $\overline{SMC0_AMSx}$ Inactive Width	$(IT + TT) \times t_{SCLK}$ – TBD		ns

Serial Ports

To determine whether communication is possible between two devices at clock speed n, the following specifications must be confirmed: 1) frame sync delay and frame sync setup and hold, 2) data delay and data setup and hold, and 3) serial clock

(SPT_CLK) width. In [Figure 40](#) either the rising edge or the falling edge of SPT_CLK (external or internal) can be used as the active sampling edge.

Table 31. Serial Ports—External Clock

Parameter	Min	Max	Unit
<i>Timing Requirements</i>			
t _{SFSE} Frame Sync Setup Before SPT_CLK (Externally Generated Frame Sync in either Transmit or Receive Mode) ¹	TBD		ns
t _{HFSE} Frame Sync Hold After SPT_CLK (Externally Generated Frame Sync in either Transmit or Receive Mode) ¹	TBD		ns
t _{SDRE} Receive Data Setup Before Receive SPT_CLK ¹	TBD		ns
t _{HDRE} Receive Data Hold After SPT_CLK ¹	TBD		ns
t _{SCLKW} SPT_CLK Width for External SPT_CLK Data/FS Receive ²	[0.5 × t _{SCLK} – TBD] or [TBD]		ns
SPT_CLK Width for External SPT_CLK Data/FS Transmit ²	[0.5 × t _{SCLK} – TBD] or [8TBD]		ns
t _{SPTCLK} SPT_CLK Period for External SPT_CLK Data/FS Receive ²	[t _{SCLK} – TBD] or [TBD]		ns
SPT_CLK Period for External SPT_CLK Data/FS Transmit ²	[t _{SCLK} – TBD] or [TBD]		ns
<i>Switching Characteristics</i>			
t _{DFSE} Frame Sync Delay After SPT_CLK (Internally Generated Frame Sync in either Transmit or Receive Mode) ³		TBD	ns
t _{HOFSE} Frame Sync Hold After SPT_CLK (Internally Generated Frame Sync in either Transmit or Receive Mode) ³	TBD		ns
t _{DDTE} Transmit Data Delay After Transmit SPT_CLK ³		TBD	ns
t _{HDTE} Transmit Data Hold After Transmit SPT_CLK ³	TBD		ns

¹ Referenced to sample edge.

² Whichever is greater.

³ Referenced to drive edge.

Table 32. Serial Ports—Internal Clock

Parameter	Min	Max	Unit
<i>Timing Requirements</i>			
t _{SFSI} Frame Sync Setup Before SPT_CLK (Externally Generated Frame Sync in either Transmit or Receive Mode) ¹	TBD		ns
t _{HFSI} Frame Sync Hold After SPT_CLK (Externally Generated Frame Sync in either Transmit or Receive Mode) ¹	TBD		ns
t _{SDRI} Receive Data Setup Before SPT_CLK ¹	TBD		ns
t _{HDRI} Receive Data Hold After SPT_CLK ¹	TBD		ns
<i>Switching Characteristics</i>			
t _{DFSI} Frame Sync Delay After SPT_CLK (Internally Generated Frame Sync in Transmit or Receive Mode) ²		TBD	ns
t _{HOFSI} Frame Sync Hold After SPT_CLK (Internally Generated Frame Sync in Transmit or Receive Mode) ²	TBD		ns
t _{DDTI} Transmit Data Delay After SPT_CLK ²		TBD	ns
t _{HDTI} Transmit Data Hold After SPT_CLK ²	TBD		ns
t _{SCLKW} SPT_CLK Width for Internal SPT_CLK Data/FS Transmit ³	[0.5 × t _{SCLK} – TBD] or [TBD]		ns
SPT_CLK Width for Internal SPT_CLK Data/FS Receive	[0.5 × t _{SCLK} – TBD] or [TBD]		ns
t _{SPTCLK} SPT_CLK Period for Internal SPT_CLK Data/FS Transmit ³	[t _{SCLK} – TBD] or [TBD]		ns
t _{SPTCLK} SPT_CLK Period for Internal SPT_CLK Data/FS Receive ³	[t _{SCLK} – TBD] or [TBD]		ns

¹ Referenced to the sample edge.

² Referenced to drive edge.

³ Whichever is greater.

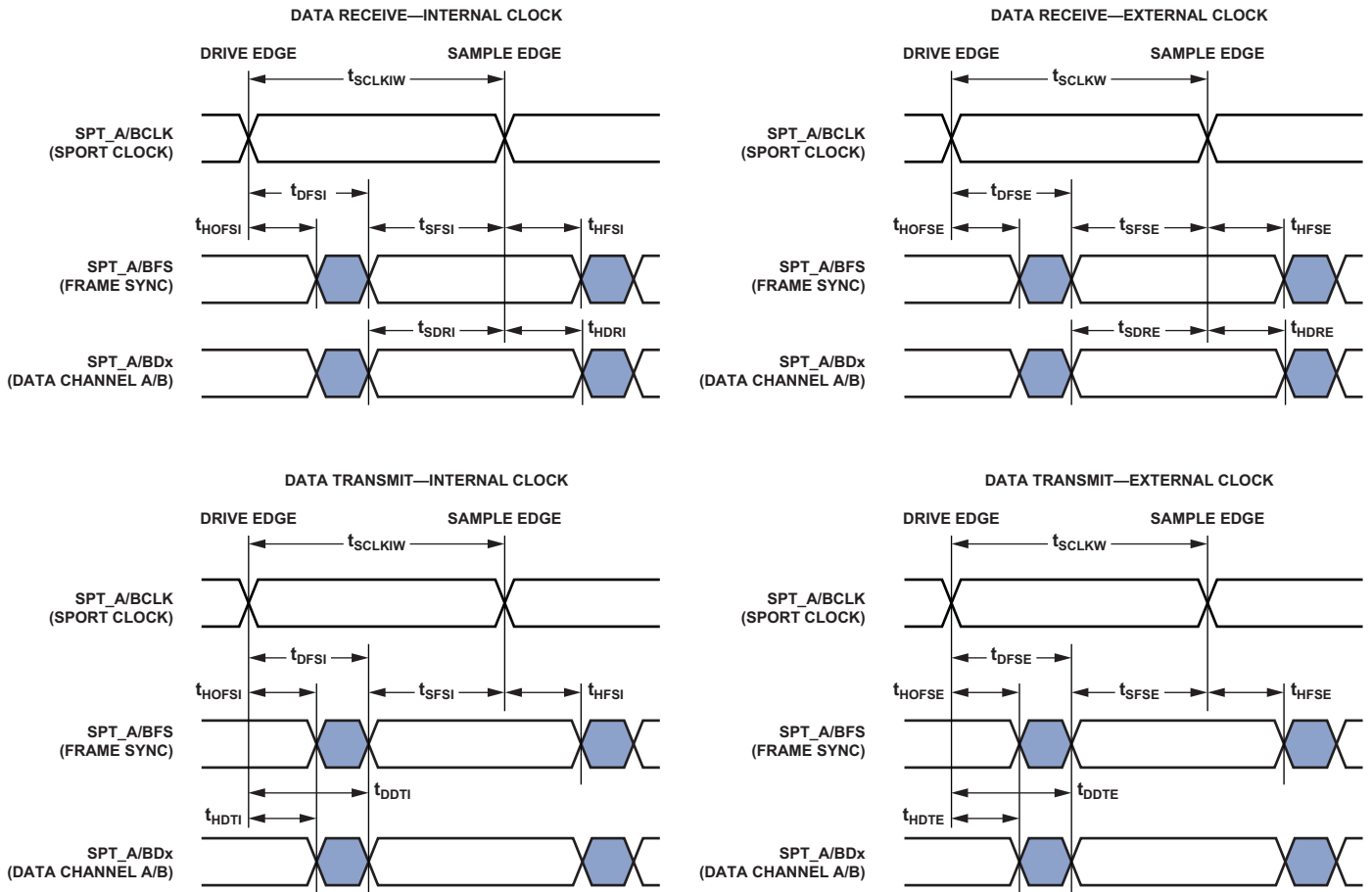

Figure 40. Serial Ports

Table 33. Serial Ports—Enable and Three-State

Parameter		Min	Max	Unit
<i>Switching Characteristics</i>				
t_{DDTEN}	Data Enable from External Transmit SPT_CLK ¹	TBD		ns
t_{DDTTE}	Data Disable from External Transmit SPT_CLK ¹		TBD	ns
t_{DDTIN}	Data Enable from Internal Transmit SPT_CLK ¹	TBD		ns
t_{DDTTI}	Data Disable from Internal Transmit SPT_CLK ¹		TBD	ns

¹Referenced to drive edge.

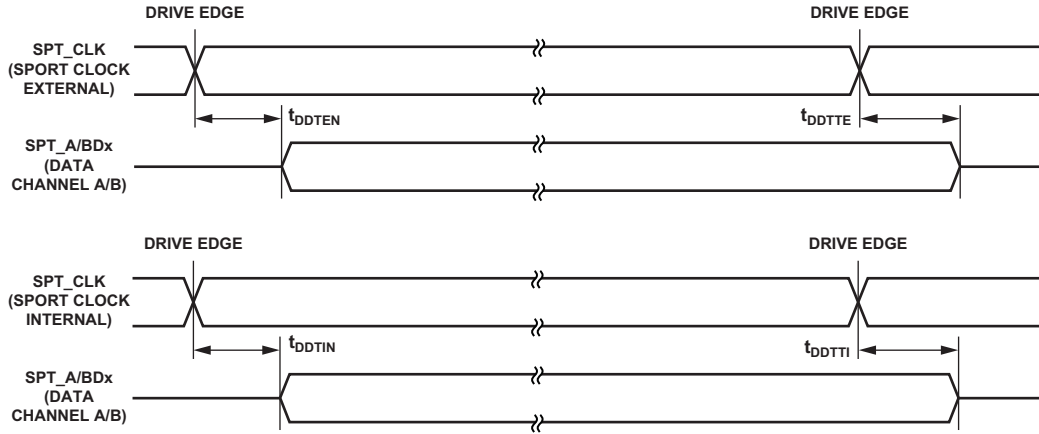

Figure 41. Serial Ports—Enable and Three-State

The SPT_TDV output signal becomes active in SPORT multi-channel mode. During transmit slots (enabled with active channel selection registers) the SPT_TDV is asserted for communication with external devices.

Table 34. Serial Ports—TDV (Transmit Data Valid)

Parameter		Min	Max	Unit
<i>Switching Characteristics</i>				
t_{DRDVEN}	Data-Valid Enable Delay from Drive Edge of External Clock ¹	TBD		ns
t_{DFDVEN}	Data-Valid Disable Delay from Drive Edge of External Clock ¹		TBD	ns
t_{DRDVIN}	Data-Valid Enable Delay from Drive Edge of Internal Clock ¹	TBD		ns
t_{DFDVIN}	Data-Valid Disable Delay from Drive Edge of Internal Clock ¹		TBD	ns

¹ Referenced to drive edge.

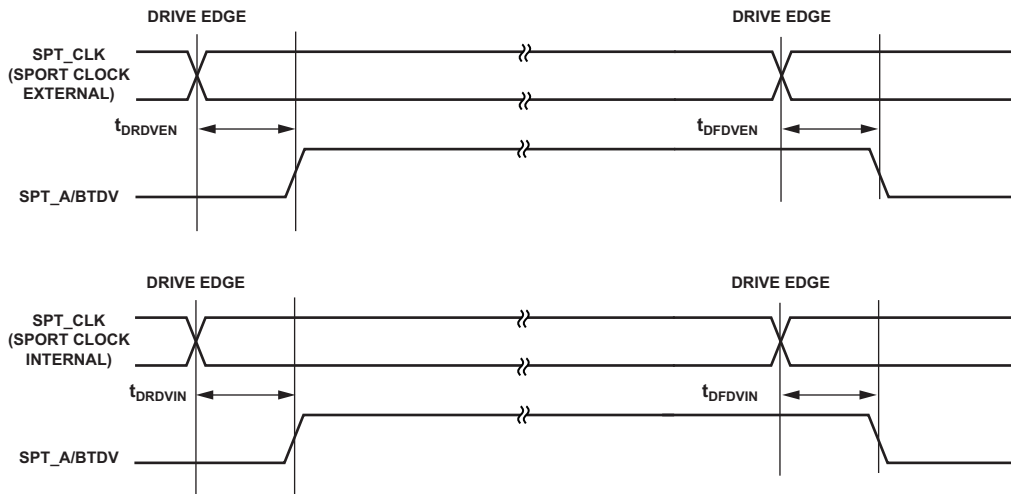

Figure 42. Serial Ports—Transmit Data Valid Internal and External Clock

Table 35. Serial Ports—External Late Frame Sync

Parameter	Min	Max	Unit
<i>Switching Characteristics</i>			
$t_{DDTLFSE}$ Data Delay from Late External Transmit Frame Sync or External Receive Frame Sync with MCE = 1, MFD = 0 ¹		TBD	ns
$t_{DDTENFS}$ Data Enable for MCE = 1, MFD = 0 ¹	TBD		ns

¹The $t_{DDTLFSE}$ and $t_{DDTENFS}$ parameters apply to left-justified as well as standard serial mode, and MCE = 1, MFD = 0.

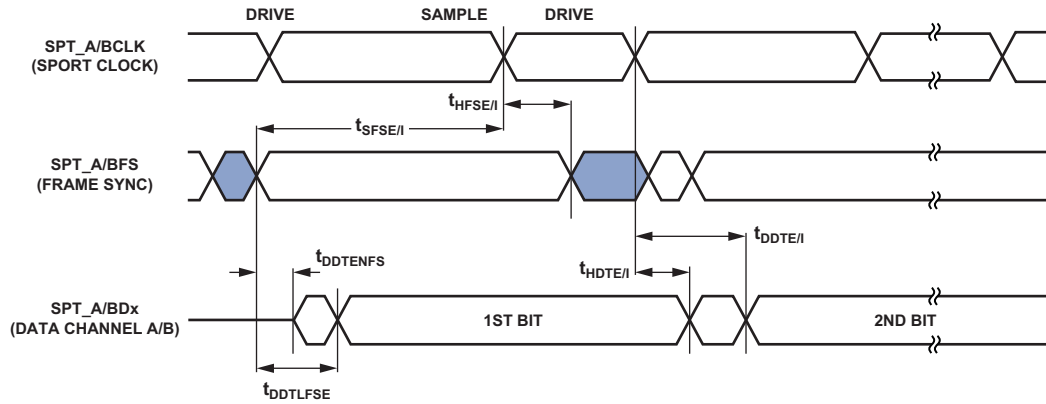

Figure 43. External Late Frame Sync

Serial Peripheral Interface (SPI) Port—Master Timing

Table 36 and Figure 44 describe SPI port master operations. Note that:

- In dual mode data transmit the SPI_MISO signal is also an output.
- In quad mode data transmit the SPI_MISO, SPI_D2, and SPI_D3 signals are also outputs.

- In dual mode data receive the SPI_MOSI signal is also an input.
- In quad mode data receive the SPI_MOSI, SPI_D2, and SPI_D3 signals are also inputs.

Table 36. Serial Peripheral Interface (SPI) Port—Master Timing

Parameter	Min	Max	Unit
<i>Timing Requirements</i>			
t_{SSPIDM} Data Input Valid to SPI_CLK Edge (Data Input Setup)	TBD		ns
t_{HSPIDM} SPI_CLK Sampling Edge to Data Input Invalid	TBD		ns
<i>Switching Characteristics</i>			
t_{SDSCIM} $\overline{\text{SPI_SEL}}$ low to First SPI_CLK Edge ¹	$[0.5 \times t_{SCLK} - \text{TBD}]$ or [TBD]		ns
t_{SPICHM} SPI_CLK High Period for Data Transmit ¹	$[0.5 \times t_{SCLK} - \text{TBD}]$ or [TBD]		ns
t_{SPICRM} SPI_CLK High Period for Data Receive ¹	$[0.5 \times t_{SCLK} - \text{TBD}]$ or [TBD]		ns
t_{SPICLM} SPI_CLK Low Period for Data Transmit ¹	$[0.5 \times t_{SCLK} - \text{TBD}]$ or [TBD]		ns
t_{SPICRM} SPI_CLK Low Period for Data Receive ¹	$[0.5 \times t_{SCLK} - \text{TBD}]$ or [TBD]		ns
t_{SPICLK} SPI_CLK Period for Data Transmit ¹	$[t_{SCLK} - \text{TBD}]$ or [TBD]		ns
t_{SPICLK} SPI_CLK Period for Data Receive ¹	$[t_{SCLK} - \text{TBD}]$ or [TBD]		ns
t_{HDSM} Last SPI_CLK Edge to $\overline{\text{SPI_SEL}}$ High	$2 \times t_{SCLK} - \text{TBD}$		ns
t_{SPITDM} Sequential Transfer Delay ^{1, 2}	$[t_{SCLK} - \text{TBD}]$ or [TBD]		ns
$t_{DDSPIDM}$ SPI_CLK Edge to Data Out Valid (Data Out Delay)		TBD	ns
$t_{HDSPIDM}$ SPI_CLK Edge to Data Out Invalid (Data Out Hold)	TBD		ns

¹ Whichever is greater.

² Applies to sequential mode with STOP ≥ 1 .

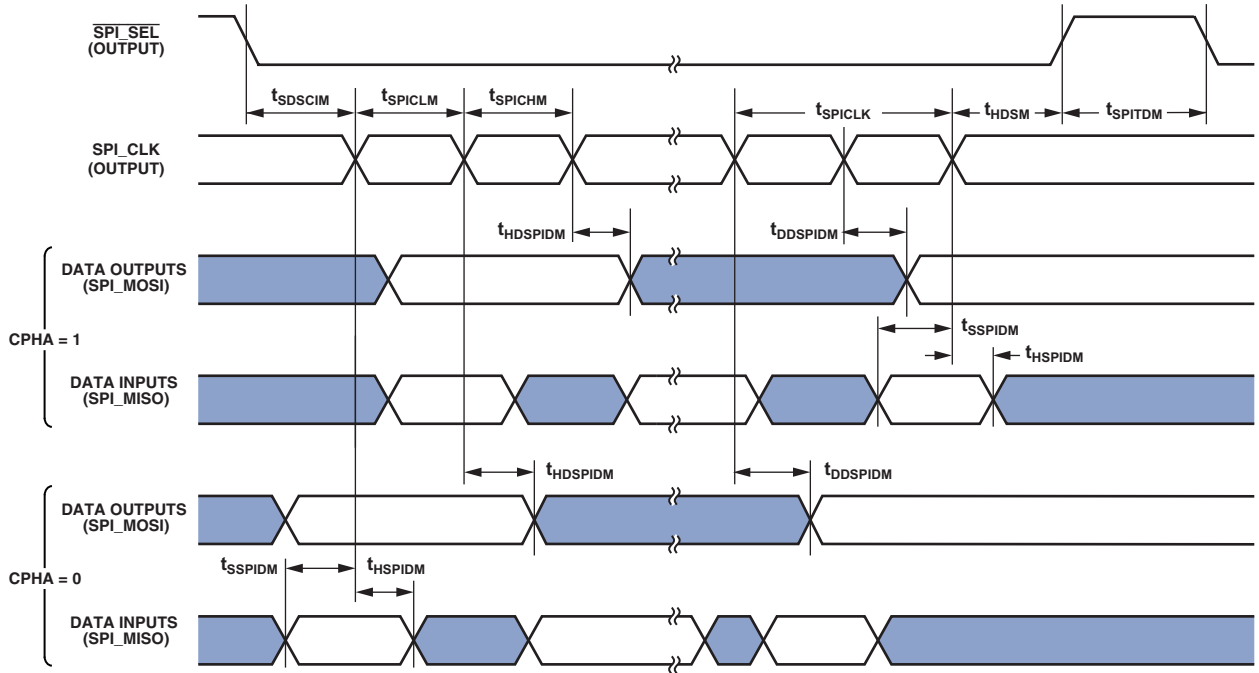

Figure 44. Serial Peripheral Interface (SPI) Port—Master Timing

Serial Peripheral Interface (SPI) Port—Slave Timing

Table 37 and Figure 45 describe SPI port slave operations. Note that:

- In dual mode data transmit the SPI_MOSI signal is also an output.
- In quad mode data transmit the SPI_MOSI, SPI_D2, and SPI_D3 signals are also outputs.

- In dual mode data receive the SPI_MISO signal is also an input.
- In quad mode data receive the SPI_MISO, SPI_D2, and SPI_D3 signals are also inputs.

Table 37. Serial Peripheral Interface (SPI) Port—Slave Timing

Parameter	Min	Max	Unit
<i>Timing Requirements</i>			
t _{SPICHS}	SPI_CLK High Period for Data Transmit ¹	[0.5 × t _{SCLK} – TBD] or [TBD]	ns
	SPI_CLK High Period for Data Receive ¹	[0.5 × t _{SCLK} – TBD] or [TBD]	ns
t _{SPICLS}	SPI_CLK Low Period for Data Transmit ¹	[0.5 × t _{SCLK} – TBD] or [TBD]	ns
	SPI_CLK Low Period for Data Receive ¹	[0.5 × t _{SCLK} – TBD] or [TBD]	ns
t _{SPICLK}	SPI_CLK Period for Data Transmit ¹	[t _{SCLK} – TBD] or [TBD]	ns
	SPI_CLK Period for Data Receive ¹	[t _{SCLK} – TBD] or [TBD]	ns
t _{HDS}	Last SPI_CLK Edge to $\overline{\text{SPI_SS}}$ Not Asserted	TBD	ns
t _{SPITDS}	Sequential Transfer Delay	0.5 × t _{SPICLK} – TBD	ns
t _{SDSCI}	$\overline{\text{SPI_SS}}$ Assertion to First SPI_CLK Edge	TBD	ns
t _{SSPID}	Data Input Valid to SPI_CLK Edge (Data Input Setup)	TBD	ns
t _{HSPID}	SPI_CLK Sampling Edge to Data Input Invalid	TBD	ns
<i>Switching Characteristics</i>			
t _{DSOE}	$\overline{\text{SPI_SS}}$ Assertion to Data Out Active	TBD	TBD
t _{SDHI}	$\overline{\text{SPI_SS}}$ Deassertion to Data High Impedance	TBD	TBD
t _{DDSPID}	SPI_CLK Edge to Data Out Valid (Data Out Delay)		TBD
t _{HDSPID}	SPI_CLK Edge to Data Out Invalid (Data Out Hold)	TBD	ns

¹ Whichever is greater.

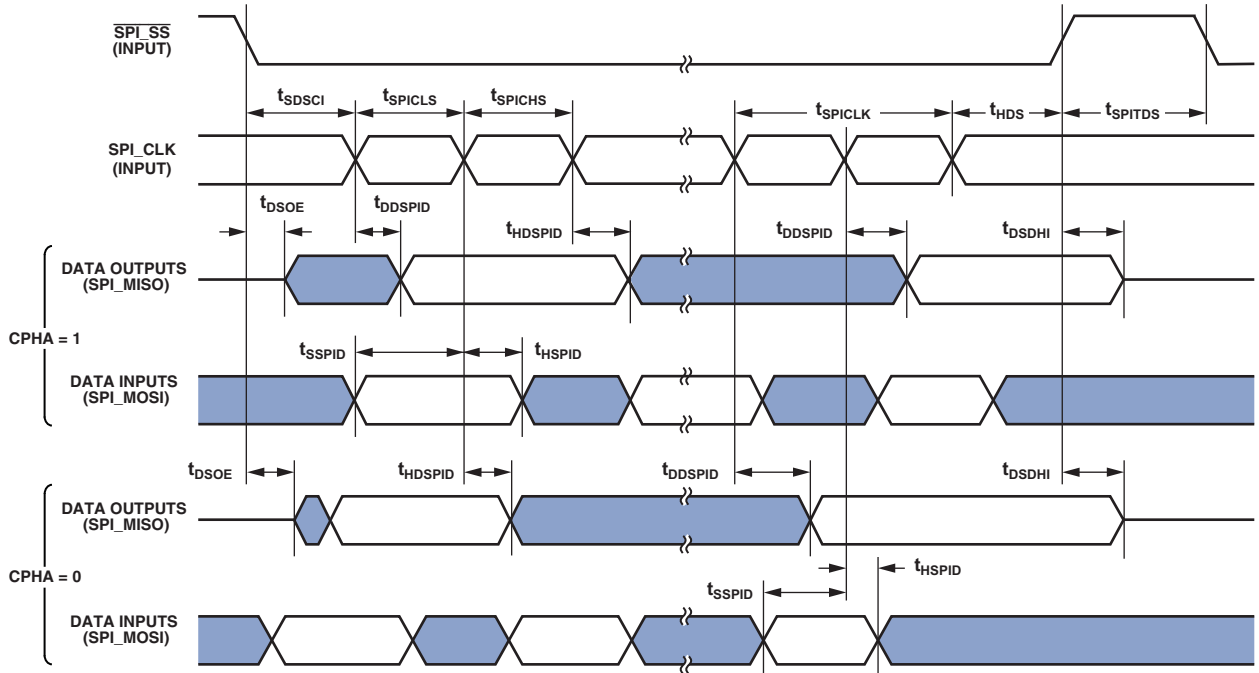

Figure 45. Serial Peripheral Interface (SPI) Port—Slave Timing

Serial Peripheral Interface (SPI) Port—SPI_RDY Slave Timing

Table 38. SPI Port—SPI_RDY Slave Timing

Parameter		Min	Max	Unit
<i>Switching Characteristics</i>				
$t_{\text{DSPISCKRDYSR}}$	SPI_RDY De-assertion from Valid Input SPI_CLK Edge in Slave Mode Receive	$2.5 \times t_{\text{SCLK}}$	$3.5 \times t_{\text{SCLK}} + \text{TBD}$	ns
$t_{\text{DSPISCKRDYST}}$	SPI_RDY De-assertion from Valid Input SPI_CLK Edge in Slave Mode Transmit	$3.5 \times t_{\text{SCLK}}$	$4.5 \times t_{\text{SCLK}} + \text{TBD}$	ns

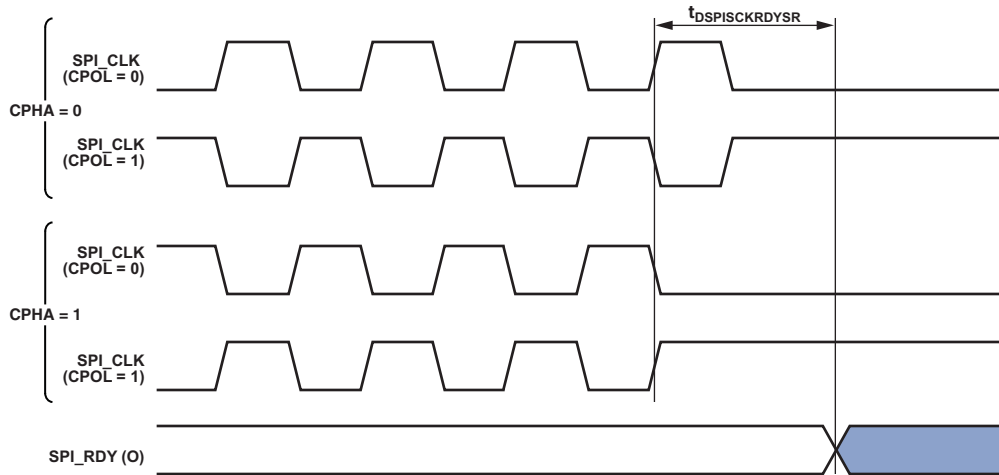

Figure 46. SPI_RDY De-assertion from Valid Input SPI_CLK Edge in Slave Mode Receive (FCCH = 0)

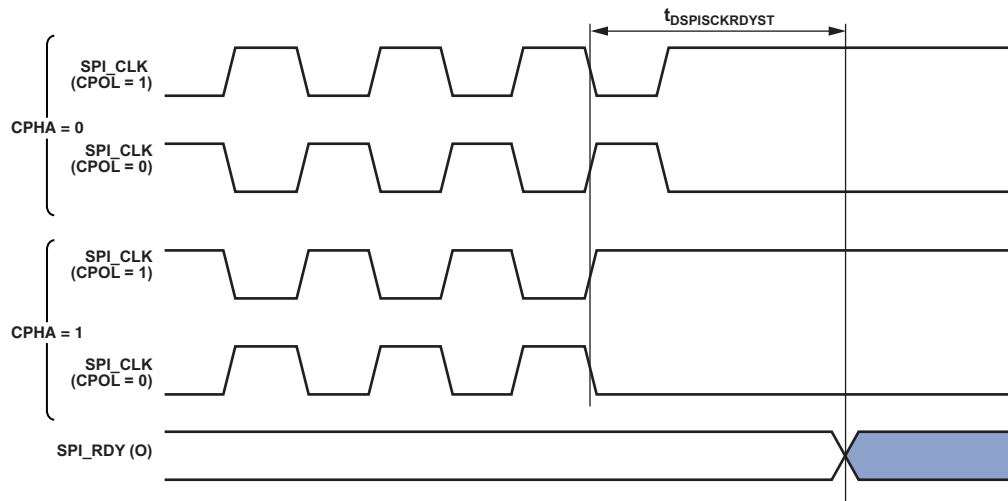

Figure 47. SPI_RDY De-assertion from Valid Input SPI_CLK Edge in Slave Mode Transmit (FCCH = 1)

Serial Peripheral Interface (SPI) Port—Open Drain Mode

Timing

In Figure 48 and Figure 49, the outputs can be SPI_MOSI, SPI_MISO, SPI_D2, and/or SPI_D3 depending on the mode of operation.

Table 39. SPI Port ODM Master Mode Timing

Parameter	Min	Max	Unit
<i>Switching Characteristics</i>			
$t_{\text{HDSPIODMM}}$ SPI_CLK Edge to High Impedance from Data Out Valid	TBD		ns
$t_{\text{DDSPIODMM}}$ SPI_CLK Edge to Data Out Valid from High Impedance	TBD	TBD	ns

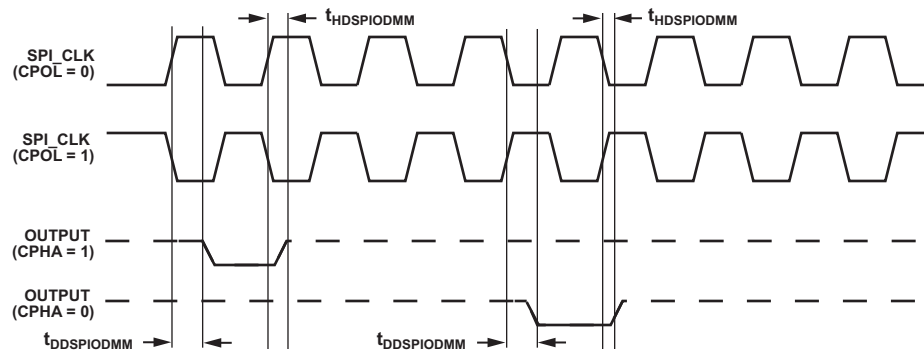

Figure 48. ODM Master

Table 40. SPI Port—ODM Slave Mode

Parameter	Min	Max	Unit
<i>Timing Requirements</i>			
$t_{\text{HDSPIODMS}}$ SPI_CLK Edge to High Impedance from Data Out Valid	TBD		ns
$t_{\text{DDSPIODMS}}$ SPI_CLK Edge to Data Out Valid from High Impedance		TBD	ns

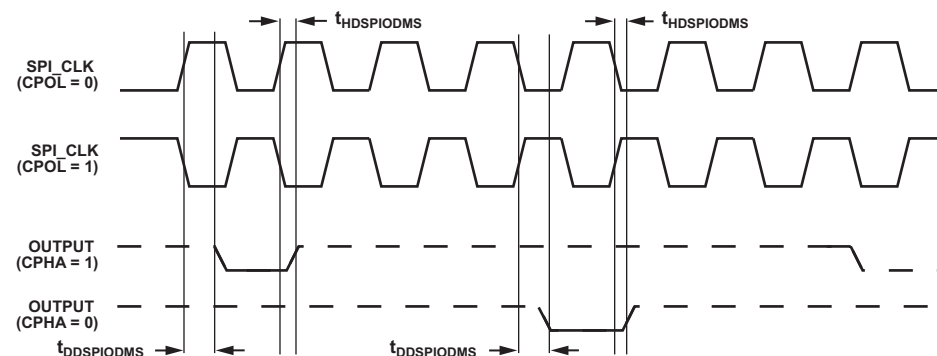

Figure 49. ODM Slave

Serial Peripheral Interface (SPI) Port—SPI_RDY Timing

Table 41. SPI Port—SPI_RDY Timing

Parameter	Min	Max	Unit
<i>Timing Requirements</i>			
$t_{SRDYSCKM0}$ Minimum Setup Time for SPI_RDY De-assertion in Master Mode Before Last SPI_CLK Edge of Valid Data Transfer to Block Subsequent Transfer with CPHA = 0	$(2.5 + 1.5 \times \text{BAUD}^1) \times t_{SCLK} + \text{TBD}$		ns
$t_{SRDYSCKM1}$ Minimum Setup Time for SPI_RDY De-assertion in Master Mode Before Last SPI_CLK Edge of Valid Data Transfer to Block Subsequent Transfer with CPHA = 1	$(1.5 \times \text{BAUD}^1) \times t_{SCLK} + \text{TBD}$		ns
<i>Switching Characteristic</i>			
$t_{SRDYSCKM}$ Time Between Assertion of SPI_RDY by Slave and First Edge of SPI_CLK for New SPI Transfer with CPHA = 0 and BAUD = 0 (STOP, LEAD, LAG = 0)	$3 \times t_{SCLK}$	$4 \times t_{SCLK} + \text{TBD}$	ns
Time Between Assertion of SPI_RDY by Slave and First Edge of SPI_CLK for New SPI Transfer with CPHA = 0 and BAUD ≥ 1 (STOP, LEAD, LAG = 0)	$(4 + 1.5 \times \text{BAUD}^1) \times t_{SCLK}$	$(5 + 1.5 \times \text{BAUD}^1) \times t_{SCLK} + \text{TBD}$	ns
Time Between Assertion of SPI_RDY by Slave and First Edge of SPI_CLK for New SPI Transfer with CPHA = 1 (STOP, LEAD, LAG = 0)	$(3 + 0.5 \times \text{BAUD}^1) \times t_{SCLK}$	$(4 + 0.5 \times \text{BAUD}^1) \times t_{SCLK} + \text{TBD}$	ns

¹ BAUD value set using the SPI_CLK.BAUD bits.

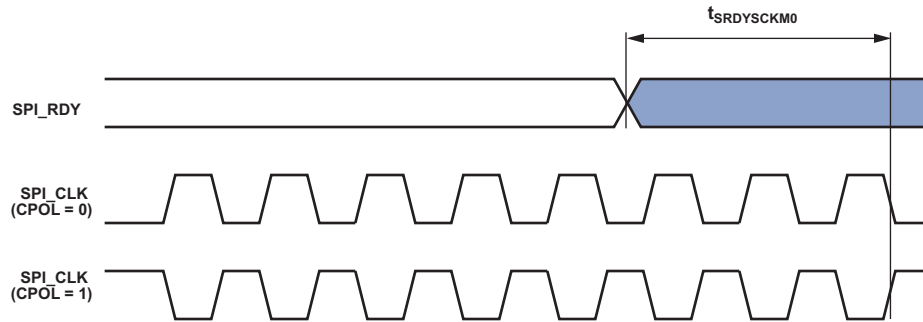

Figure 50. SPI_RDY Setup Before SPI_CLK with CPHA = 0

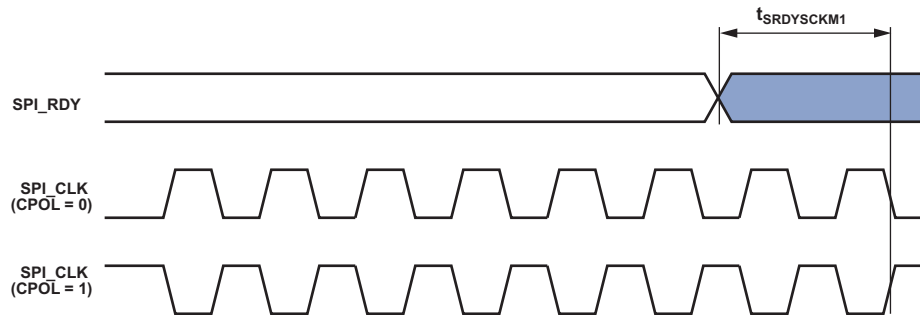

Figure 51. SPI_RDY Setup Before SPI_CLK with CPHA = 1

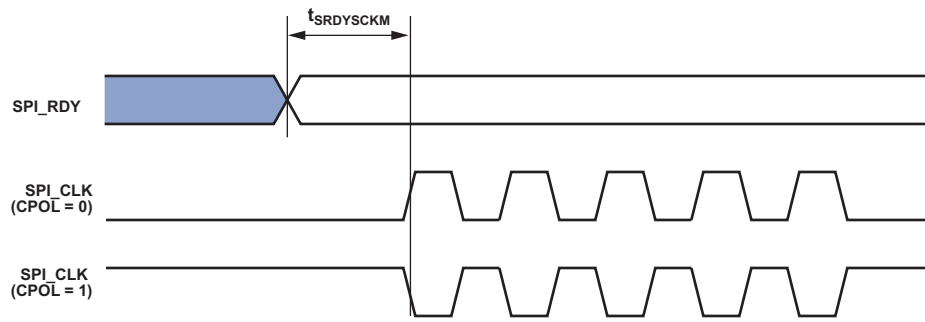

Figure 52. SPI_CLK Switching Diagram after SPI_RDY Assertion, CPHA = x

General-Purpose Port Timing

Table 42 and Figure 53 describe general-purpose port operations.

Table 42. General-Purpose Port Timing

Parameter	Min	Max	Unit
<i>Timing Requirement</i>			
t_{WFI} General-Purpose Port Pin Input Pulse Width	$2 \times t_{SCLK}$		ns

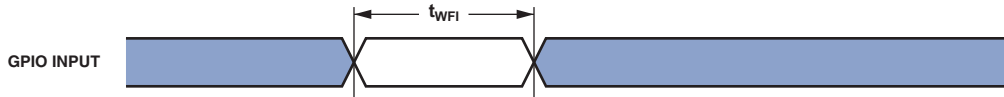

Figure 53. General-Purpose Port Timing

Timer Cycle Timing

Table 43 and Figure 54 describe timer expired operations. The input signal is asynchronous in “width capture mode” and “external clock mode” and has an absolute maximum input fre-

quency of ($f_{SCLK}/4$) MHz. The Width Value value is the timer period assigned in the TMx_TMRn_WIDTH register and can range from 1 to $2^{32} - 1$.

Table 43. Timer Cycle Timing

Parameter	Min	Max	Unit
<i>Timing Requirements</i>			
t_{WL} Timer Pulse Width Input Low (Measured In SCLK Cycles) ¹	$2 \times t_{SCLK}$		ns
t_{WH} Timer Pulse Width Input High (Measured In SCLK Cycles) ¹	$2 \times t_{SCLK}$		ns
<i>Switching Characteristics</i>			
t_{HTO} Timer Pulse Width Output (Measured In SCLK Cycles)	$t_{SCLK} \times \text{Width Value} - \text{TBD}$	$t_{SCLK} \times \text{Width Value} + \text{TBD}$	ns

¹The minimum pulse widths apply for TMx signals in width capture and external clock modes.

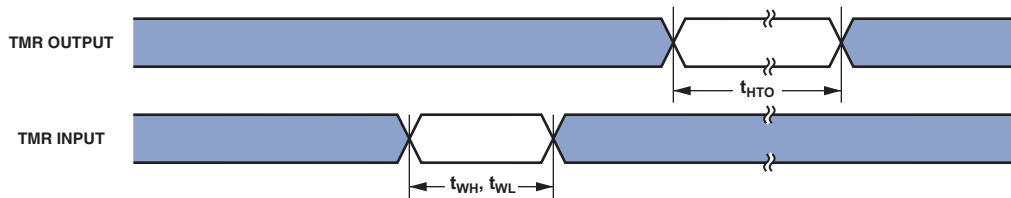

Figure 54. Timer Cycle Timing

Up/Down Counter/Rotary Encoder Timing

Table 44. Up/Down Counter/Rotary Encoder Timing

Parameter	Min	Max	Unit
<i>Timing Requirement</i>			
t_{WCOUNT} Up/Down Counter/Rotary Encoder Input Pulse Width	$2 \times t_{SCLK}$		ns

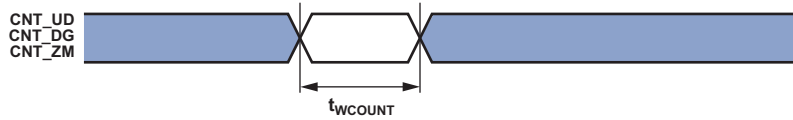

Figure 55. Up/Down Counter/Rotary Encoder Timing

Pulse Width Modulator (PWM) Timing

Table 45 and Figure 56 describe PWM operations.

Table 45. PWM Timing

Parameter	Min	Max	Unit
<i>Timing Requirement</i>			
t_{ES} External Sync Pulse Width	$2 \times t_{SCLK}$		ns
<i>Switching Characteristics</i>			
t_{DODIS} Output Inactive (OFF) After Trip Input ¹		TBD	ns
t_{DOE} Output Delay After External Sync ^{1, 2}	$2 \times t_{SCLK} + TBD$	$5 \times t_{SCLK} + TBD$	ns

¹ PWM outputs are: PWMx_AH, PWMx_AL, PWMx_BH, PWMx_BL, PWMx_CH, and PWMx_CL.

² When the external sync signal is synchronous to the peripheral clock, it takes fewer clock cycles for the output to appear compared to when the external sync signal is asynchronous to the peripheral clock. For more information, see the ADSP-CM40x Microcontroller Hardware Reference.

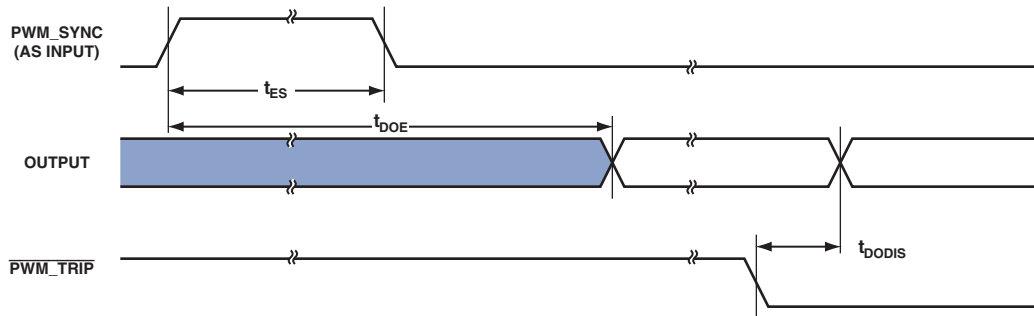

Figure 56. PWM Timing

Universal Asynchronous Receiver-Transmitter (UART) Ports—Receive and Transmit Timing

The UART ports receive and transmit operations are described in the *ADSP-CM40x Mixed-Signal Control Processor with ARM Cortex-M4 Hardware Reference*.

CAN Interface

The CAN interface timing is described in the *ADSP-CM40x Mixed-Signal Control Processor with ARM Cortex-M4 Hardware Reference*.

Universal Serial Bus (USB) On-The-Go—Receive and Transmit Timing

The USB interface timing is described in the *ADSP-CM40x Mixed-Signal Control Processor with ARM Cortex-M4 Hardware Reference*.

10/100 Ethernet MAC Controller Timing

Table 46 through Table 48 and Figure 57 through Figure 59 describe the 10/100 Ethernet MAC Controller operations.

Table 46. 10/100 Ethernet MAC Controller Timing: RMII Receive Signal

Parameter ¹	Min	Max	Unit
<i>Timing Requirements</i>			
$t_{REFCLKF}$ ETHx_REFCLK Frequency ($f_{SCLK} = SCLK$ Frequency)	None	50 + 1%	MHz
$t_{REFCLKW}$ ETHx_REFCLK Width ($t_{REFCLK} = ETHx_REFCLK$ Period)	$t_{REFCLK} \times 35\%$	$t_{REFCLK} \times 65\%$	ns
$t_{REFCLKIS}$ Rx Input Valid to RMII ETHx_REFCLK Rising Edge (Data In Setup)	TBD		ns
$t_{REFCLKIH}$ RMII ETHx_REFCLK Rising Edge to Rx Input Invalid (Data In Hold)	TBD		ns

¹ RMII inputs synchronous to RMII REF_CLK are ERxD1-0, RMII CRS_DV, and ERxER.

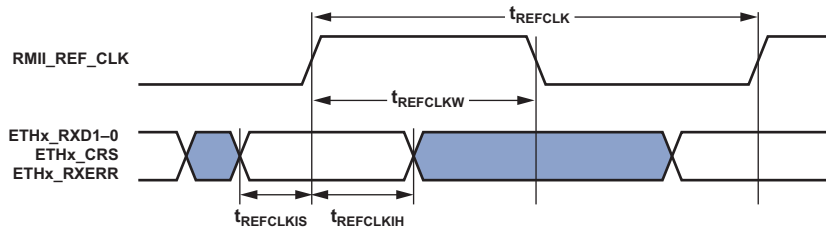

Figure 57. 10/100 Ethernet MAC Controller Timing: RMII Receive Signal

Table 47. 10/100 Ethernet MAC Controller Timing: RMII Transmit Signal

Parameter ¹	Min	Max	Unit
<i>Switching Characteristics</i>			
$t_{REFCLKOV}$ RMII ETHx_REFCLK Rising Edge to Transmit Output Valid (Data Out Valid)		TBD	ns
$t_{REFCLKOH}$ RMII ETHx_REFCLK Rising Edge to Transmit Output Invalid (Data Out Hold)	TBD		ns

¹ RMII outputs synchronous to RMII REF_CLK are ETxD1-0.

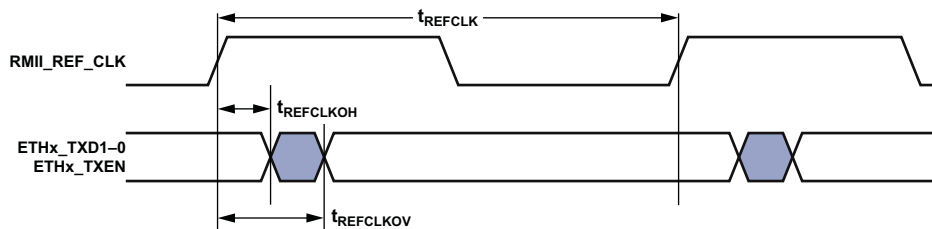

Figure 58. 10/100 Ethernet MAC Controller Timing: RMII Transmit Signal

Table 48. 10/100 Ethernet MAC Controller Timing: RMI Station Management

Parameter ¹	Min	Max	Unit
<i>Timing Requirements</i>			
t_{MDIOS} ETHx_MDIO Input Valid to ETHx_MDC Rising Edge (Setup)	TBD		ns
t_{MDCIH} ETHx_MDC Rising Edge to ETHx_MDIO Input Invalid (Hold)	TBD		ns
<i>Switching Characteristics</i>			
t_{MDCOV} ETHx_MDC Falling Edge to ETHx_MDIO Output Valid		$t_{SCLK} + TBD$	ns
t_{MDCOH} ETHx_MDC Falling Edge to ETHx_MDIO Output Invalid (Hold)	$t_{SCLK} - TBD$		ns

¹ ETHx_MDC/ETHx_MDIO is a 2-wire serial bidirectional port for controlling one or more external PHYs. ETHx_MDC is an output clock whose minimum period is programmable as a multiple of the system clock SCLK. ETHx_MDIO is a bidirectional data line.

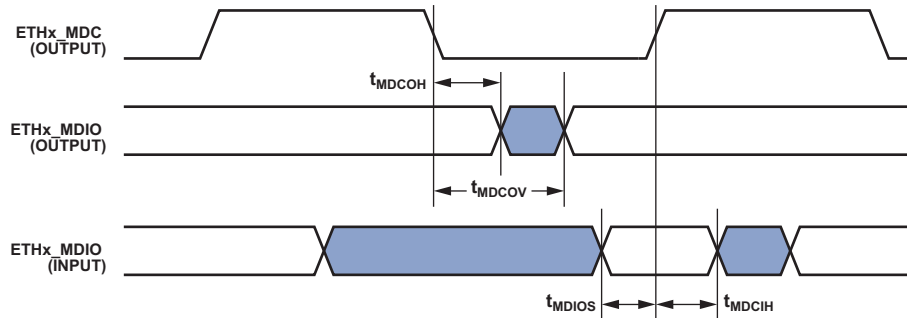

Figure 59. 10/100 Ethernet MAC Controller Timing: RMI Station Management

JTAG Test And Emulation Port Timing

Table 49 and Figure 60 describe JTAG port operations.

Table 49. JTAG Port Timing

Parameter		Min	Max	Unit
<i>Timing Requirements</i>				
t_{TCK}	JTG_TCK Period	20		ns
t_{STAP}	JTG_TDI, JTG_TMS Setup Before JTG_TCK High	TBD		ns
t_{HTAP}	JTG_TDI, JTG_TMS Hold After JTG_TCK High	TBD		ns
t_{SSYS}	System Inputs Setup Before JTG_TCK High ¹	TBD		ns
t_{HSYS}	System Inputs Hold After JTG_TCK High ¹	TBD		ns
t_{TRSTW}	JTG_TRST Pulse Width (measured in JTG_TCK cycles) ²	TBD		TCK
<i>Switching Characteristics</i>				
t_{DTDO}	JTG_TDO Delay from JTG_TCK Low		TBD	ns
t_{DSYS}	System Outputs Delay After JTG_TCK Low ³		TBD	ns

¹ System Inputs = PA_15-0, PB_15-0, PC_15-0, PD_15-0, PE_15-0, PF_10-0, SYS_BMODE0-1, SYS_HWRST, SYS_FAULT, SYS_NMI, TWI0_SCL, TWI0_SDA.

² 50 MHz Maximum.

³ System Outputs = PA_15-0, PB_15-0, PC_15-0, PD_15-0, PE_15-0, PF_10-0, SMC0_AMS0, SMC0_ARE, SMC0_AWE, SYS_CLKOUT, SYS_FAULT, SYS_RESOUT.

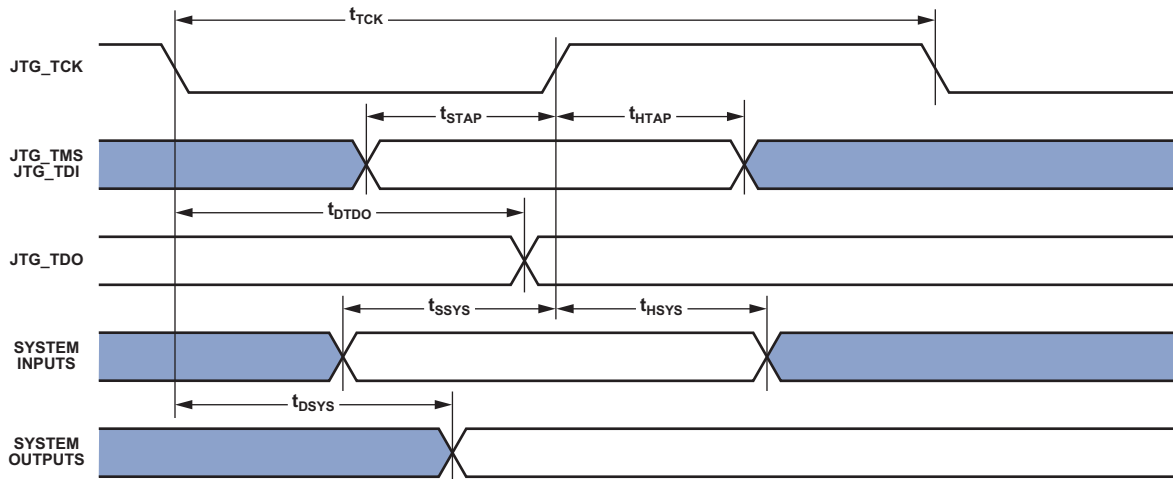

Figure 60. JTAG Port Timing

OUTPUT DRIVE CURRENTS

Figure 61 and Figure 62 show typical current-voltage characteristics for the output drivers of the processors. The curves represent the current drive capability of the output drivers as a function of output voltage.

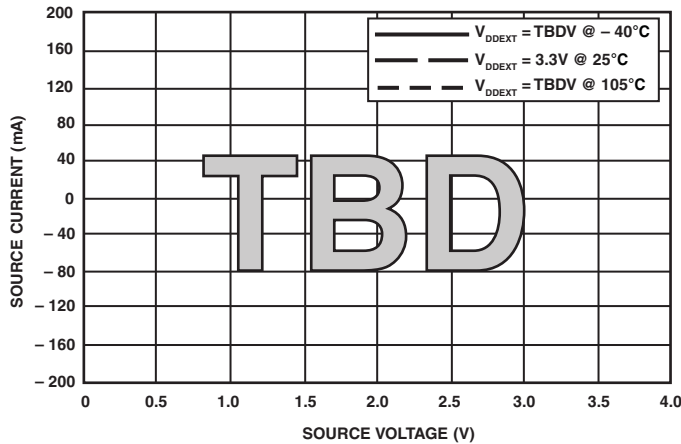

Figure 61. Driver Type A Current

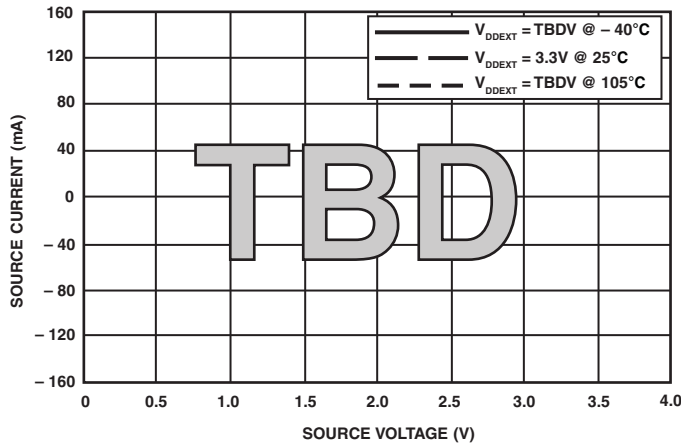
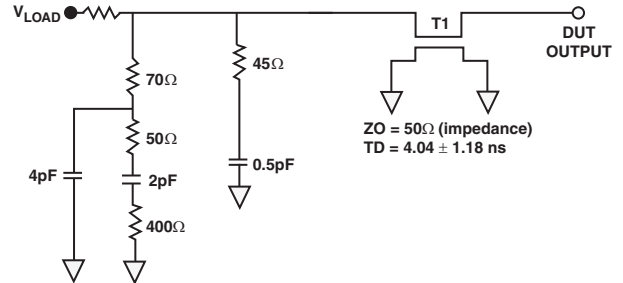

Figure 62. Driver Type B Current

Capacitive Loading

Output delays and holds are based on standard capacitive loads of an average of 6 pF on all pins (see Figure 63). V_{LOAD} is equal to $(V_{DD_EXT})/2$.



NOTES:
THE WORST CASE TRANSMISSION LINE DELAY IS SHOWN AND CAN BE USED FOR THE OUTPUT TIMING ANALYSIS TO REFLECT THE TRANSMISSION LINE EFFECT AND MUST BE CONSIDERED. THE TRANSMISSION LINE (TD), IS FOR LOAD ONLY AND DOES NOT AFFECT THE DATA SHEET TIMING SPECIFICATIONS.

ANALOG DEVICES RECOMMENDS USING THE IBIS MODEL TIMING FOR A GIVEN SYSTEM REQUIREMENT. IF NECESSARY, A SYSTEM MAY INCORPORATE EXTERNAL DRIVERS TO COMPENSATE FOR ANY TIMING DIFFERENCES.

Figure 63. Equivalent Device Loading for AC Measurements (Includes All Fixtures)

The graph of Figure 64 shows how output rise and fall times vary with capacitance. The delay and hold specifications given should be derated by a factor derived from these figures. The graphs in these figures may not be linear outside the ranges shown.

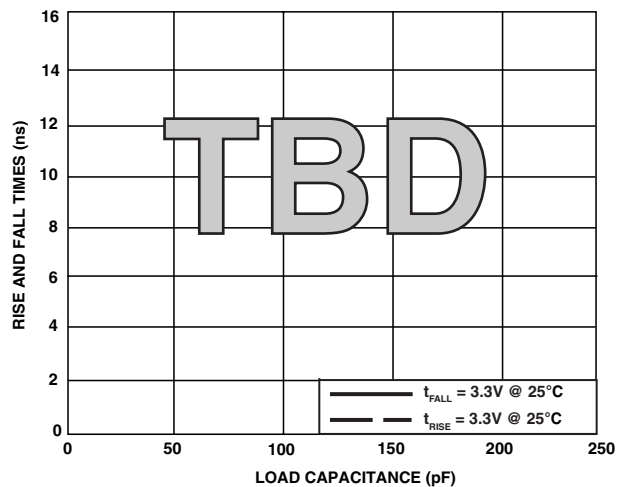

Figure 64. Driver Type A Typical Rise and Fall Times (10%-90%) vs. Load Capacitance

ENVIRONMENTAL CONDITIONS

To determine the junction temperature on the application printed circuit board use:

$$T_J = T_{CASE} + (\Psi_{JT} \times P_D)$$

where:

T_J = Junction temperature (°C)

T_{CASE} = Case temperature (°C) measured by customer at top center of package.

Ψ_{JT} = From [Table 50](#) and [Table 51](#)

P_D = Power dissipation (see [Total Power Dissipation on Page 35](#) for the method to calculate P_D)

Table 50. Thermal Characteristics (120-Lead LQFP)

Parameter	Condition	Typical	Unit
θ_{JA}	0 linear m/s air flow	21.5	°C/W
θ_{JA}	1 linear m/s air flow	19.2	°C/W
θ_{JA}	2 linear m/s air flow	18.4	°C/W
θ_{JC}		9.29	°C/W
Ψ_{JT}	0 linear m/s air flow	0.25	°C/W
Ψ_{JT}	1 linear m/s air flow	0.40	°C/W
Ψ_{JT}	2 linear m/s air flow	0.56	°C/W

Table 51. Thermal Characteristics (176-Lead LQFP)

Parameter	Condition	Typical	Unit
θ_{JA}	0 linear m/s air flow	21.5	°C/W
θ_{JA}	1 linear m/s air flow	19.3	°C/W
θ_{JA}	2 linear m/s air flow	18.5	°C/W
θ_{JC}		9.24	°C/W
Ψ_{JT}	0 linear m/s air flow	0.25	°C/W
Ψ_{JT}	1 linear m/s air flow	0.37	°C/W
Ψ_{JT}	2 linear m/s air flow	0.48	°C/W

Values of θ_{JA} are provided for package comparison and printed circuit board design considerations. θ_{JA} can be used for a first order approximation of T_J by the equation:

$$T_J = T_A + (\theta_{JA} \times P_D)$$

where:

T_A = Ambient temperature (°C)

Values of θ_{JC} are provided for package comparison and printed circuit board design considerations when an external heat sink is required.

In [Table 50](#) and [Table 51](#), airflow measurements comply with JEDEC standards JESD51-2 and JESD51-6. The junction-to-case measurement complies with MIL-STD-883 (Method 1012.1). All measurements use a 2S2P JEDEC test board.

120-LEAD LQFP LEAD ASSIGNMENTS

Table 52 lists the 120-lead LQFP package by lead number and

Table 53 lists the 120-lead LQFP package by signal.

Table 52. 120-lead LQFP Lead Assignment (Numerical by Lead Number)

Lead No.	Signal Name	Lead No.	Signal Name	Lead No.	Signal Name	Lead No.	Signal Name
1	PA_13	32	JTG_TRST	63	ADC1_VIN05	94	DAC0_VOUT
2	VDD_EXT	33	JTG_TDO/SWO	64	ADC1_VIN06	95	VDD_EXT
3	PA_12	34	JTG_TMS/SWDIO	65	ADC1_VIN07	96	VDD_INT
4	PA_11	35	PC_07	66	ADC1_VIN08	97	VDD_EXT
5	PA_10	36	VDD_EXT	67	ADC1_VIN09	98	GND
6	PA_09	37	PC_06	68	ADC1_VIN10	99	SYS_NMI
7	PA_08	38	PC_05	69	ADC1_VIN11	100	VDD_EXT
8	PA_07	39	PC_04	70	VDD_ANA1	101	VDD_EXT
9	VDD_EXT	40	PC_03	71	GND_ANA1	102	PB_10
10	PA_06	41	PC_02	72	BYP_A1	103	PB_08
11	PA_05	42	PC_01	73	VREF1	104	PB_09
12	PA_04	43	VDD_EXT	74	GND_VREF1	105	PB_06
13	PA_03	44	VDD_INT	75	REFCAP	106	PB_07
14	PA_02	45	PC_00	76	GND_VREF0	107	PB_05
15	PA_01	46	PB_14	77	VREF0	108	VDD_INT
16	VDD_INT	47	PB_15	78	BYP_A0	109	VDD_EXT
17	VDD_EXT	48	PB_13	79	GND_ANA0	110	PB_04
18	SYS_RESOUT	49	VDD_EXT	80	VDD_ANA0	111	PB_03
19	PA_00	50	PB_11	81	ADC0_VIN11	112	PB_02
20	SYS_FAULT	51	PB_12	82	ADC0_VIN10	113	PB_01
21	SYS_HWRST	52	GND	83	ADC0_VIN09	114	PB_00
22	VDD_EXT	53	VDD_EXT	84	ADC0_VIN08	115	PA_15
23	SYS_XTAL	54	VDD_INT	85	ADC0_VIN07	116	VDD_EXT
24	SYS_CLKIN	55	BYP_D0	86	ADC0_VIN06	117	PA_14
25	VREG_BASE	56	DAC1_VOUT	87	ADC0_VIN05	118	SYS_CLKOUT
26	VDD_VREG	57	ADC1_VIN00	88	ADC0_VIN04	119	SYS_BMODE1
27	VDD_EXT	58	ADC1_VIN01	89	ADC0_VIN03	120	SYS_BMODE0
28	TWI0_SCL	59	ADC1_VIN02	90	GND_ANA2	121*	GND
29	TWI0_SDA	60	ADC1_VIN03	91	ADC0_VIN02		
30	JTG_TDI	61	GND_ANA3	92	ADC0_VIN01		
31	JTG_TCK/SWCLK	62	ADC1_VIN04	93	ADC0_VIN00		

* Pin no. 121 is the GND supply (see Figure 66) for the processor; this pad **must** connect to GND.

Table 53. 120-lead LQFP Lead Assignment (Alphabetical by Signal Name)

Signal Name	Lead No.	Signal Name	Lead No.	Signal Name	Lead No.	Signal Name	Lead No.
ADC0_VIN00	93	GND	121*	PB_03	111	TWIO_SCL	28
ADC0_VIN01	92	GND_ANA0	79	PB_04	110	TWIO_SDA	29
ADC0_VIN02	91	GND_ANA1	71	PB_05	107	VDD_ANA0	80
ADC0_VIN03	89	GND_ANA2	90	PB_06	105	VDD_ANA1	70
ADC0_VIN04	88	GND_ANA3	61	PB_07	106	VDD_EXT	2
ADC0_VIN05	87	GND_VREF0	76	PB_08	103	VDD_EXT	9
ADC0_VIN06	86	GND_VREF1	74	PB_09	104	VDD_EXT	17
ADC0_VIN07	85	JTG_TCK/SWCLK	31	PB_10	102	VDD_EXT	22
ADC0_VIN08	84	JTG_TDI	30	PB_11	50	VDD_EXT	27
ADC0_VIN09	83	JTG_TDO/SWO	33	PB_12	51	VDD_EXT	36
ADC0_VIN10	82	JTG_TMS/SWDIO	34	PB_13	48	VDD_EXT	43
ADC0_VIN11	81	JTG_TRST	32	PB_14	46	VDD_EXT	49
ADC1_VIN00	57	PA_00	19	PB_15	47	VDD_EXT	53
ADC1_VIN01	58	PA_01	15	PC_00	45	VDD_EXT	95
ADC1_VIN02	59	PA_02	14	PC_01	42	VDD_EXT	97
ADC1_VIN03	60	PA_03	13	PC_02	41	VDD_EXT	100
ADC1_VIN04	62	PA_04	12	PC_03	40	VDD_EXT	101
ADC1_VIN05	63	PA_05	11	PC_04	39	VDD_EXT	109
ADC1_VIN06	64	PA_06	10	PC_05	38	VDD_EXT	116
ADC1_VIN07	65	PA_07	8	PC_06	37	VDD_INT	16
ADC1_VIN08	66	PA_08	7	PC_07	35	VDD_INT	44
ADC1_VIN09	67	PA_09	6	REFCAP	75	VDD_INT	54
ADC1_VIN10	68	PA_10	5	SYS_BMODE0	120	VDD_INT	96
ADC1_VIN11	69	PA_11	4	SYS_BMODE1	119	VDD_INT	108
BYP_A0	78	PA_12	3	SYS_CLKIN	24	VDD_VREG	26
BYP_A1	72	PA_13	1	SYS_CLKOUT	118	VREF0	77
BYP_D0	55	PA_14	117	SYS_FAULT	20	VREF1	73
DAC0_VOUT	94	PA_15	115	SYS_HWRST	21	VREG_BASE	25
DAC1_VOUT	56	PB_00	114	SYS_NMI	99		
GND	98	PB_01	113	SYS_RESOUT	18		
GND	52	PB_02	112	SYS_XTAL	23		

* Pin no. 121 is the GND supply (see [Figure 66](#)) for the processor; this pad **must** connect to GND.

Figure 65 shows the top view of the 120-lead LQFP package lead configuration and Figure 66 shows the bottom view of the 120-lead LQFP package lead configuration.

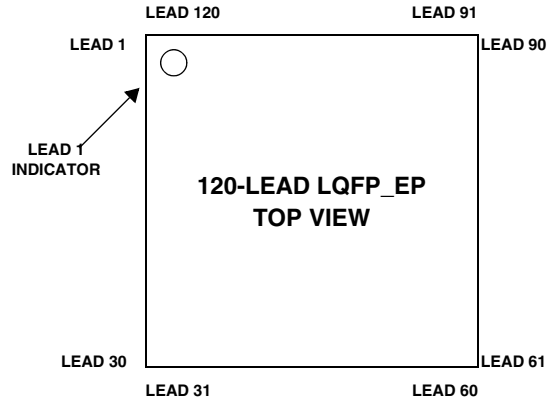

Figure 65. 120-Lead LQFP Package Lead Configuration (Top View)

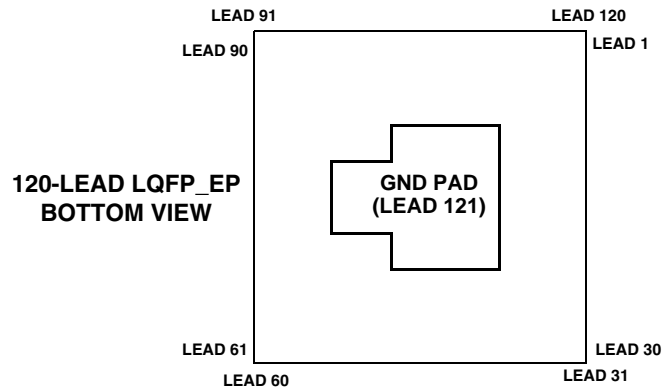

Figure 66. 120-Lead LQFP Package Lead Configuration (Bottom View)

176-LEAD LQFP LEAD ASSIGNMENTS

Table 54 lists the 176-lead LQFP package by lead number and

Table 55 lists the 176-lead LQFP package by signal.

Table 54. 176-lead LQFP Lead Assignment (Numerical by Lead Number)

Lead No.	Signal Name	Lead No.	Signal Name	Lead No.	Signal Name	Lead No.	Signal Name
1	PA_13	46	JTG_TRST	91	PE_05	136	VDD_EXT
2	VDD_EXT	47	JTG_TDO/SWO	92	PE_04	137	VDD_EXT
3	PA_12	48	JTG_TMS/SWDIO	93	VDD_EXT	138	PD_12
4	PA_11	49	PC_07	94	VDD_INT	139	PD_13
5	PC_15	50	VDD_EXT	95	BYP_D0	140	PD_10
6	PA_10	51	PC_05	96	GND_ANA3	141	PD_11
7	PC_14	52	PC_06	97	ADC1_VIN00	142	PD_08
8	VDD_EXT	53	PF_10	98	ADC1_VIN01	143	PD_09
9	PC_13	54	PC_04	99	ADC1_VIN02	144	VDD_EXT
10	PC_11	55	PF_08	100	ADC1_VIN03	145	PD_07
11	PC_12	56	PF_09	101	ADC1_VIN04	146	PD_06
12	PA_09	57	VDD_EXT	102	ADC1_VIN05	147	SMCO_AMSO
13	PA_08	58	PF_06	103	ADC1_VIN06	148	SMCO_AWE
14	PA_07	59	PF_07	104	ADC1_VIN07	149	SMCO_ARE
15	VDD_EXT	60	PC_03	105	VDD_ANA1	150	VDD_EXT
16	PA_06	61	PF_05	106	GND_ANA1	151	PB_10
17	PA_05	62	PC_01	107	BYP_A1	152	PB_09
18	PA_04	63	PC_02	108	VREF1	153	PB_08
19	PA_03	64	VDD_EXT	109	GND_VREF1	154	PB_07
20	PA_02	65	VDD_INT	110	REFCAP	155	PB_06
21	PA_01	66	PC_00	111	GND_VREF0	156	PB_05
22	VDD_INT	67	PF_04	112	VREF0	157	VDD_INT
23	VDD_EXT	68	PF_03	113	BYP_A0	158	VDD_EXT
24	SYS_RESOUT	69	PF_02	114	GND_ANA0	159	PB_03
25	PA_00	70	PF_01	115	VDD_ANA0	160	PB_04
26	SYS_FAULT	71	PF_00	116	ADC0_VIN07	161	PD_05
27	SYS_HWRST	72	VDD_EXT	117	ADC0_VIN06	162	PB_02
28	VDD_EXT	73	PE_15	118	ADC0_VIN05	163	PD_03
29	SYS_XTAL	74	PE_14	119	ADC0_VIN04	164	PD_04
30	SYS_CLKIN	75	PE_13	120	ADC0_VIN03	165	VDD_EXT
31	VREG_BASE	76	PB_14	121	ADC0_VIN02	166	PD_01
32	VDD_VREG	77	PB_15	122	ADC0_VIN01	167	PD_02
33	VDD_EXT	78	PB_13	123	ADC0_VIN00	168	PB_01
34	USB0_DM	79	VDD_EXT	124	GND_ANA2	169	PD_00
35	USB0_DP	80	PB_11	125	VDD_EXT	170	PA_15
36	USB0_VBUS	81	PB_12	126	PE_03	171	PB_00
37	USB0_ID	82	PE_12	127	PE_02	172	VDD_EXT
38	PC_10	83	GND	128	VDD_INT	173	PA_14
39	PC_08	84	PE_11	129	VDD_EXT	174	SYS_CLKOUT
40	PC_09	85	PE_10	130	PE_01	175	SYS_BMODE1
41	VDD_EXT	86	VDD_EXT	131	GND	176	SYS_BMODE0

* Pin no. 177 is the GND supply (see Figure 68) for the processor; this pad **must** connect to GND.

Table 54. 176-lead LQFP Lead Assignment (Numerical by Lead Number)

Lead No.	Signal Name	Lead No.	Signal Name	Lead No.	Signal Name	Lead No.	Signal Name
42	TWI0_SCL	87	PE_09	132	SYS_NMI	177*	GND
43	TWI0_SDA	88	PE_08	133	PE_00		
44	JTG_TDI	89	PE_07	134	PD_15		
45	JTG_TCK/SWCLK	90	PE_06	135	PD_14		

* Pin no. 177 is the GND supply (see [Figure 68](#)) for the processor; this pad **must** connect to GND.

Table 55. 176-lead LQFP Lead Assignment (Alphabetical by Signal Name)

Signal Name	Lead No.	Signal Name	Lead No.	Signal Name	Lead No.	Signal Name	Lead No.
ADC0_VIN00	123	PA_12	3	PD_09	143	SYS_RESOUT	24
ADC0_VIN01	122	PA_13	1	PD_10	140	SYS_XTAL	29
ADC0_VIN02	121	PA_14	173	PD_11	141	TWIO_SCL	42
ADC0_VIN03	120	PA_15	170	PD_12	138	TWIO_SDA	43
ADC0_VIN04	119	PB_00	171	PD_13	139	USB0_DM	34
ADC0_VIN05	118	PB_01	168	PD_14	135	USB0_DP	35
ADC0_VIN06	117	PB_02	162	PD_15	134	USB0_ID	37
ADC0_VIN07	116	PB_03	159	PE_00	133	USB0_VBUS	36
ADC1_VIN00	97	PB_04	160	PE_01	130	VDD_ANA0	115
ADC1_VIN01	98	PB_05	156	PE_02	127	VDD_ANA1	105
ADC1_VIN02	99	PB_06	155	PE_03	126	VDD_EXT	2
ADC1_VIN03	100	PB_07	154	PE_04	92	VDD_EXT	8
ADC1_VIN04	101	PB_08	153	PE_05	91	VDD_EXT	15
ADC1_VIN05	102	PB_09	152	PE_06	90	VDD_EXT	23
ADC1_VIN06	103	PB_10	151	PE_07	89	VDD_EXT	28
ADC1_VIN07	104	PB_11	80	PE_08	88	VDD_EXT	33
BYP_A0	113	PB_12	81	PE_09	87	VDD_EXT	41
BYP_A1	107	PB_13	78	PE_10	85	VDD_EXT	50
BYP_D0	95	PB_14	76	PE_11	84	VDD_EXT	57
GND	131	PB_15	77	PE_12	82	VDD_EXT	64
GND	83	PC_00	66	PE_13	75	VDD_EXT	72
GND	177*	PC_01	62	PE_14	74	VDD_EXT	79
GND_ANA0	114	PC_02	63	PE_15	73	VDD_EXT	86
GND_ANA1	106	PC_03	60	PF_00	71	VDD_EXT	93
GND_ANA2	124	PC_04	54	PF_01	70	VDD_EXT	125
GND_ANA3	96	PC_05	51	PF_02	69	VDD_EXT	129
GND_VREF0	111	PC_06	52	PF_03	68	VDD_EXT	136
GND_VREF1	109	PC_07	49	PF_04	67	VDD_EXT	137
JTG_TCK/SWCLK	45	PC_08	39	PF_05	61	VDD_EXT	144
JTG_TDI	44	PC_09	40	PF_06	58	VDD_EXT	150
JTG_TDO/SWO	47	PC_10	38	PF_07	59	VDD_EXT	158
JTG_TMS/SWDIO	48	PC_11	10	PF_08	55	VDD_EXT	165
JTG_TRST	46	PC_12	11	PF_09	56	VDD_EXT	172
PA_00	25	PC_13	9	PF_10	53	VDD_INT	22
PA_01	21	PC_14	7	REFCAP	110	VDD_INT	65
PA_02	20	PC_15	5	SMC0_AMS0	147	VDD_INT	94
PA_03	19	PD_00	169	SMC0_ARE	149	VDD_INT	128
PA_04	18	PD_01	166	SMC0_AWE	148	VDD_INT	157
PA_05	17	PD_02	167	SYS_BMODE0	176	VDD_VREG	32
PA_06	16	PD_03	163	SYS_BMODE1	175	VREF0	112
PA_07	14	PD_04	164	SYS_CLKIN	30	VREF1	108
PA_08	13	PD_05	161	SYS_CLKOUT	174	VREG_BASE	31
PA_09	12	PD_06	146	SYS_FAULT	26		
PA_10	6	PD_07	145	SYS_HWRST	27		
PA_11	4	PD_08	142	SYS_NMI	132		

* Pin no. 177 is the GND supply (see Figure 68) for the processor; this pad **must** connect to GND.

Figure 67 shows the top view of the 176-lead LQFP lead configuration and Figure 68 shows the bottom view of the 176-lead LQFP lead configuration.

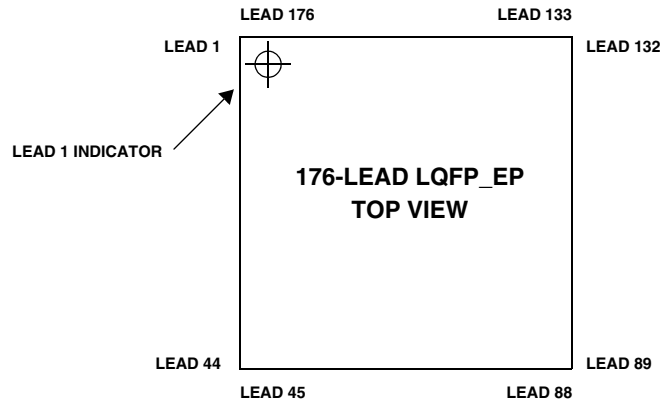

Figure 67. 176-Lead LQFP_EP Lead Configuration (Top View)

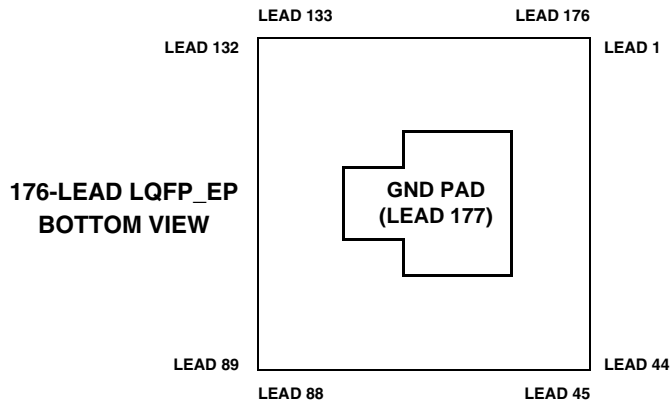
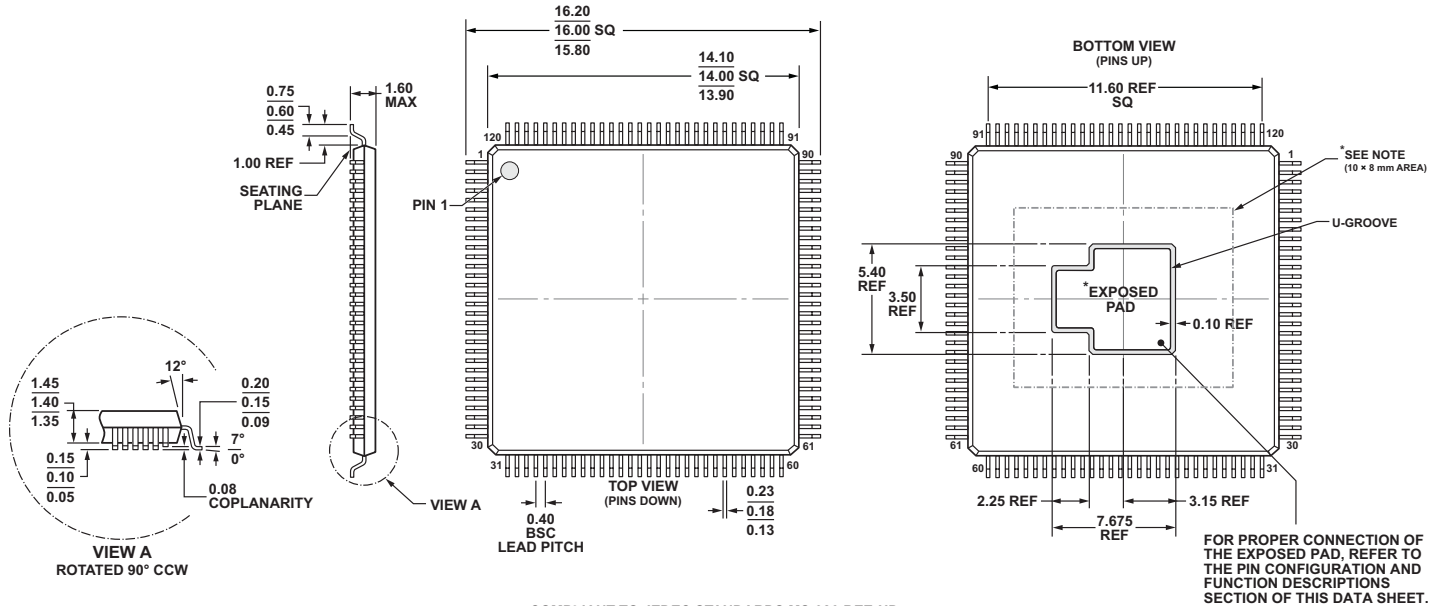

Figure 68. 176-Lead LQFP_EP Lead Configuration (Bottom View)

OUTLINE DIMENSIONS

Dimensions in [Figure 69](#) (for the 120-lead LQFP) and in [Figure 70](#) (for the 176-lead LQFP) are shown in millimeters.



COMPLIANT TO JEDEC STANDARDS MS-026-BEE-HD
 *NOTE: EXPOSED PAD DIMENSIONS ARE PRELIMINARY AND FOR ENG GRADE MATERIAL ONLY. THE PAD SIZE MAY CHANGE FOR VOLUME PRODUCTION MATERIAL. TO MAINTAIN COMPATIBILITY PCB DESIGNERS MUST OBSERVE THE SPECIFIED KEEP-OUT AREA.

Figure 69. 120-Lead Low Profile Quad Flat Package, Exposed Pad [LQFP_EP]¹
 (SW-120-3)

Dimensions shown in millimeters

¹ For information relating to the SW-120-3 package's exposed pad, see the table endnote in [120-Lead LQFP Lead Assignments on Page 74](#).

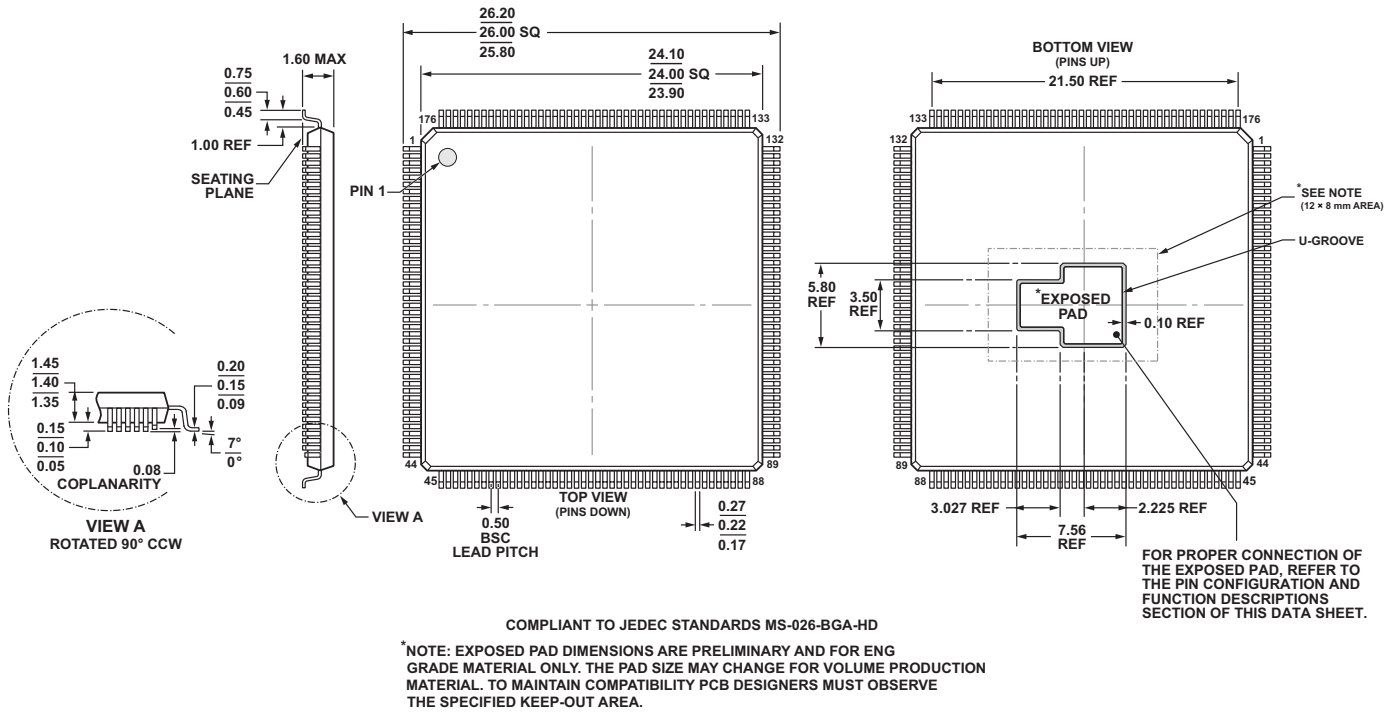

Figure 70. 176-Lead Low Profile Quad Flat Package, Exposed Pad [LQFP_EP]¹
(SW-176-3)
Dimensions shown in millimeters

¹ For information relating to the SW-176-3 package's exposed pad, see the table endnote in [176-Lead LQFP Lead Assignments on Page 77](#).

PRE-RELEASE PRODUCTS

Model	Temperature Range ^{1, 2}	Package Description	Package Option	Processor Instruction Rate (Max)
ADSP-CM403FBSWZENG	TBD	120-Lead Low-profile Quad Flat Package Exposed Pad	SW-120-3	TBD MHz
ADSP-CM408FBSWZENG	TBD	176-Lead Low-profile Quad Flat Package Exposed Pad	SW-176-3	TBD MHz

¹ Referenced temperature is ambient temperature. The ambient temperature is not a specification. Please see [Operating Conditions on Page 34](#) for the junction temperature (T_J) specification which is the only temperature specification.

² Actual temperature range for ENG grade product is subject to change, and will be provided to the customer at the time of shipment. The production target for ambient temperature is -40°C to +85°C.

