



3.5"W x 6"L x 1.75"H

- 90-264VAC Auto Ranging Input
- Compact Footprint
- High Efficiency
- Regulated Outputs
- 4242VDC Isolation
- Built in EMI Filter



<u>Model Number</u>	<u>Output Voltage</u>	<u>Output Amps (max)</u>	<u>Ripple/Noise pp,typ</u>
MK150S-5	5 VDC	30	100mv
MK150S-12	12 VDC	12.5	100mv
MK150S-15	15 VDC	10	100mv
MK150S-24	24 VDC	6.25	100mv

INPUT SPECIFICATIONS

Input Voltage Range	90-132/176-264 VAC
	100-120 / 200-240VAC Nominal
Frequency Range	47-63 Hz
Inrush Current, typ:	20A @ 100VAC *
	40A @ 200VAC *
Leakage Current	<3.5mA @ 264VAC, 50Hz

OUTPUT SPECIFICATIONS

Voltage and Current	See Selection Chart
Line/Load Regulation (NL-FL)	± 0.5%, typ
Voltage Tolerance	± 1%, typ
DC Voltage Adjust (typ)	± 6%, typ
Temperature Coefficient	± 0.03%/°C
Ripple/Noise	100mV, typ
Over Voltage Protection	130% max. Auto recovery *
Over Current Protection	160% max., Auto-recovery *
Short Circuit Protection	Auto-recovery
Hold Up Time	20mS, typ (Nom I/P, FL)
Turn On Time	≤ 1.5 sec, typ
Rise Time	≤ 250mS, typ
Over/Under Shoot	< 10% of FS

GENERAL SPECIFICATIONS

Isolation	I/P-O/P: 4242VDC
	I/P-Ground: 2121VDC
	O/P-Ground: 707VDC
Efficiency	77~80%, typ
Switching Frequency	100Khz, (fixed, typical)
Safety UL/cUL:	UL60950-1 2nd ed./ C22.2 60950-1 2nd ed.
UL-EU:	EN60950-1 2nd ed.
CE:	EN60601-1-2
CB:	IEC60950-1 2nd ed.

ENVIRONMENTAL SPECIFICATIONS

Oper. Temperature	0 to +60°C
	(See Derate Curve)
Storage Temperature	-25 to +85°C *
Relative Humidity	10% to 90%, non-cond *
EMI (Designed to Meet)	EN55011, Class B
MTBF	100,000 Hrs
	Mil Std 217, 25°C

PHYSICAL SPECIFICATIONS

Size	6" x 3.5" x 1.75"
Construction	Enclosed
Weight	1.37 lb, (630g)

All specifications are typical at nominal input, full load, and 25°C unless otherwise noted

* These are stress ratings. Exposure of the devices to any of these conditions may adversely affect long term reliability. Proper operation under conditions other than the standard operating conditions is neither warranted nor implied.

MECHANICAL DIMENSIONS

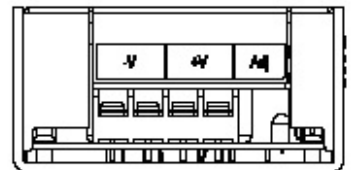
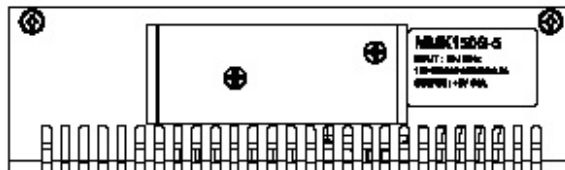
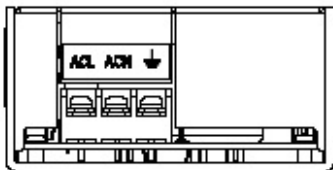
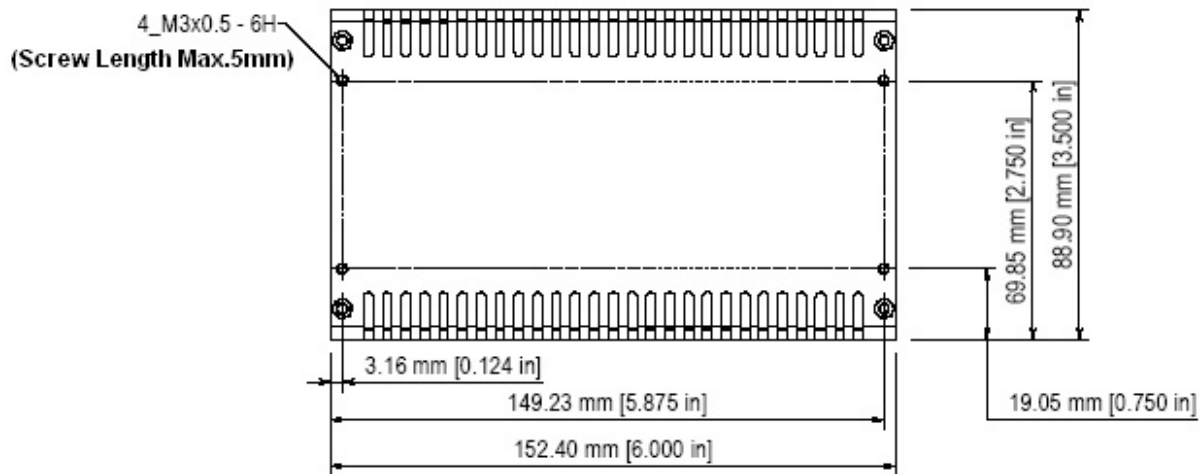
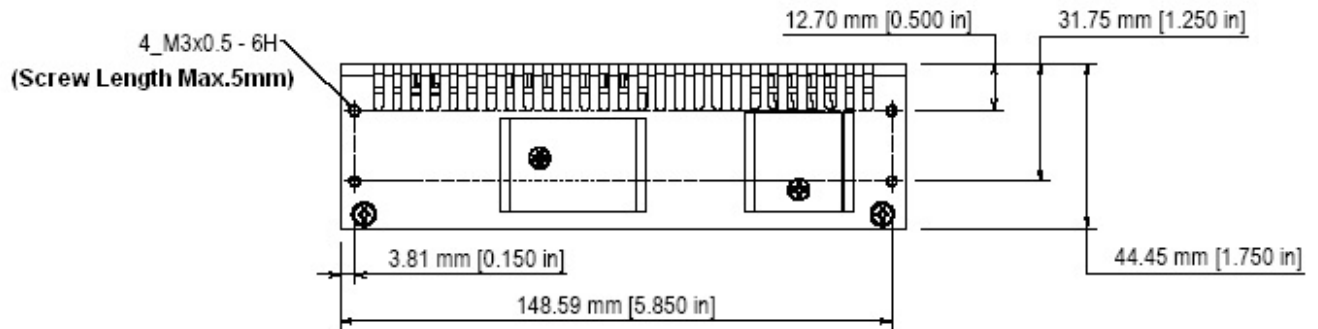

PLEASE NOTE:

To improve specifications and safety isolation, connection designations may have changed from prior revisions. Please verify connections per product labels on input and output connections prior to applying power to the unit

Note: For our M3 x 0.5 aluminum threaded holes:
Recommended torque: 2.5 in-lbs, 3 in-lbs maximum (2.9 kgf-cm/3.5 kgf-cm max)

OUTPUT DERATING CURVE

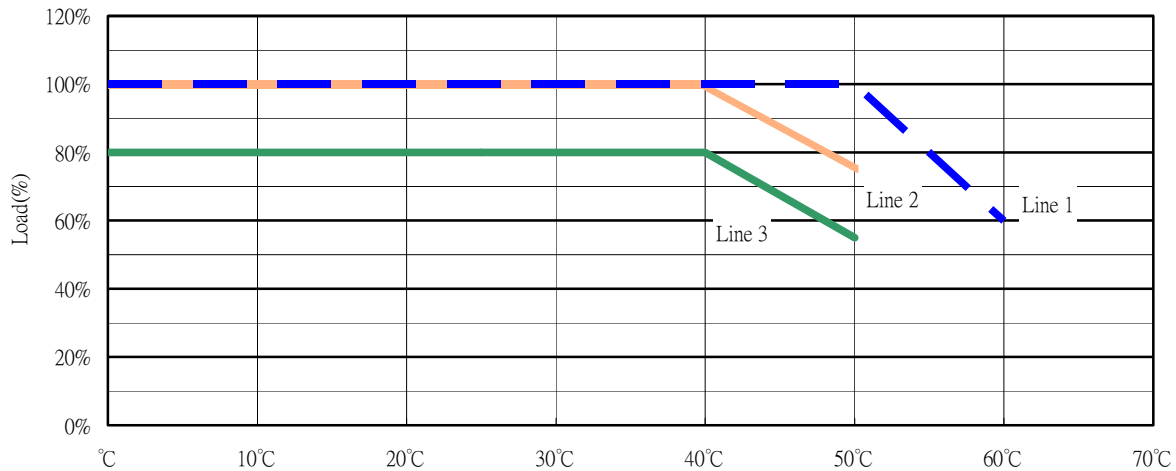

- 1. Line 1 : Force air cooling.
- 2. Line 2 : 12V, 15V & 24V convection cooling.
- 3. Line 3 : 5V convection cooling.