

PLEASE CHECK WWW.MOLEX.COM FOR LATEST PART INFORMATION

Part Number: [0022281080](#)
Status: **Active**
Description: 2.54mm (.100") Pitch KK® Header, Breakaway, Right Angle, with Friction Lock, 8 Circuits, Tin (Sn) Plating

Documents:

[3D Model](#) [Product Specification PS-10-07 \(PDF\)](#)
[Packaging Specification \(PDF\)](#) [RoHS Certificate of Compliance \(PDF\)](#)
[Drawing \(PDF\)](#)

Agency Certification

CSA LR19980
 UL E29179

General

Product Family PCB Headers
 Series [42228](#)
 Application Wire-to-Board
 Product Name KK®

Physical

Breakaway Yes
 Circuits (Loaded) 8
 Circuits (maximum) 8
 Color - Resin Black
 Durability (mating cycles max) 25
 Flammability 94V-0
 Glow-Wire Compliant No
 Lock to Mating Part Yes
 Material - Metal Brass
 Material - Plating Mating Tin
 Material - Plating Termination Tin
 Material - Resin Nylon
 Number of Rows 1
 Orientation Right Angle
 PC Tail Length (in) 0.120 In
 PC Tail Length (mm) 3.05 mm
 PCB Locator No
 PCB Retention None
 PCB Thickness Recommended (in) 0.062 In
 PCB Thickness Recommended (mm) 1.60 mm
 Packaging Type Bag
 Pitch - Mating Interface (in) 0.100 In
 Pitch - Mating Interface (mm) 2.54 mm
 Plating min: Mating (µin) 100
 Plating min: Mating (µm) 2.5
 Plating min: Termination (µin) 100
 Plating min: Termination (µm) 2.5
 Polarized to Mating Part Yes
 Polarized to PCB No
 Shrouded Partial
 Stackable No
 Temperature Range - Operating 0°C to +75°C
 Termination Interface: Style Through Hole

Electrical

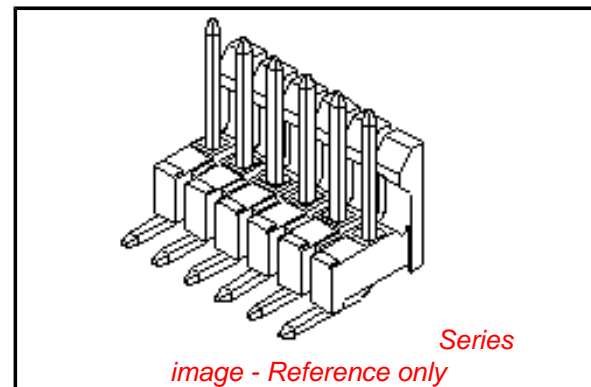

EU RoHS

ELV and RoHS Compliant
REACH SVHC Contains SVHC: No
Halogen-Free Status
Not Reviewed

China RoHS



Need more information on product environmental compliance?

Email productcompliance@molex.com
 For a multiple part number RoHS Certificate of Compliance, [click here](#)

Please visit the [Contact Us](#) section for any non-product compliance questions.

Search Parts in this Series

[42228Series](#)

Mates With

[2695](#) , [6471](#) , [7880](#) , [4455](#) , [7720](#)

| | |
|-------------------------------|------|
| Current - Maximum per Contact | 4A |
| Voltage - Maximum | 250V |

Solder Process Data

| | |
|--|------------------------|
| Duration at Max. Process Temperature (seconds) | 5 |
| Lead-free Process Capability | Wave Capable (TH only) |
| Max. Cycles at Max. Process Temperature | 1 |
| Process Temperature max. C | 235 |

Material Info

| | |
|-----------------|------------|
| Old Part Number | 42228-0008 |
|-----------------|------------|

Reference - Drawing Numbers

| | |
|-----------------------|--|
| Product Specification | PS-10-07 |
| Sales Drawing | SD-42228-001, SD-42228-002, SD-42228-003 |

This document was generated on 03/22/2010

PLEASE CHECK WWW.MOLEX.COM FOR LATEST PART INFORMATION

| CKTS | DM A | DM B |
|------|-------------|-------------|
| 2 | .200/5.08 | .100/2.54 |
| 3 | .300/7.62 | .200/5.08 |
| 4 | .400/10.16 | .300/7.62 |
| 5 | .500/12.70 | .400/10.16 |
| 6 | .600/15.24 | .500/12.70 |
| 7 | .700/17.78 | .600/15.24 |
| 8 | .800/20.32 | .700/17.78 |
| 9 | .900/22.86 | .800/20.32 |
| 10 | 1.000/25.40 | .900/22.86 |
| 11 | 1.100/27.94 | 1.000/25.40 |
| 12 | 1.200/30.48 | 1.100/27.94 |
| 13 | 1.300/33.02 | 1.200/30.48 |
| 14 | 1.400/35.56 | 1.300/33.02 |
| 15 | 1.500/38.10 | 1.400/35.56 |
| 16 | 1.600/40.64 | 1.500/38.10 |
| 17 | 1.700/43.18 | 1.600/40.64 |
| 18 | 1.800/45.72 | 1.700/43.18 |
| 19 | 1.900/48.26 | 1.800/45.72 |
| 20 | 2.000/50.80 | 1.900/48.26 |
| 21 | 2.100/53.34 | 2.000/50.80 |
| 22 | 2.200/55.88 | 2.100/53.34 |
| 23 | 2.300/58.42 | 2.200/55.88 |
| 24 | 2.400/60.96 | 2.300/58.42 |
| 25 | 2.500/63.50 | 2.400/60.96 |
| 26 | 2.600/66.04 | 2.500/63.50 |
| 27 | 2.700/68.58 | 2.600/66.04 |
| 28 | 2.800/71.12 | 2.700/68.58 |
| 29 | 2.900/73.66 | 2.800/71.12 |
| 30 | 3.000/76.20 | 2.900/73.66 |
| 31 | 3.100/78.74 | 3.000/76.20 |
| 32 | 3.200/81.28 | 3.100/78.74 |
| 33 | 3.300/83.82 | 3.200/81.28 |
| 34 | 3.400/86.36 | 3.300/83.82 |
| 35 | 3.500/88.90 | 3.400/86.36 |
| 36 | 3.600/91.44 | 3.500/88.90 |

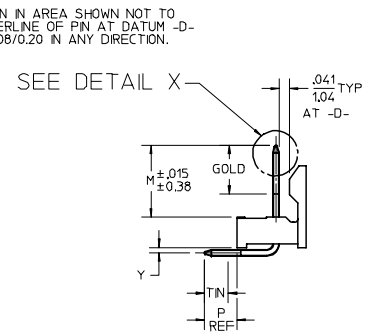
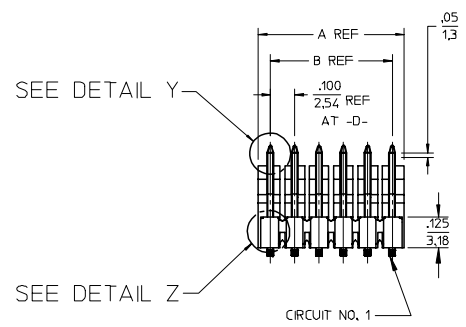
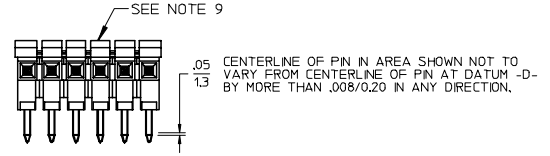
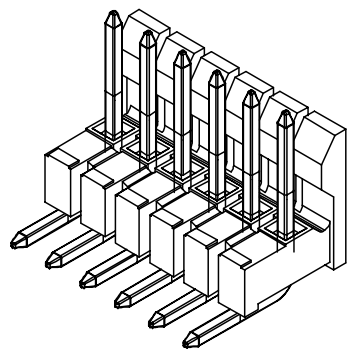
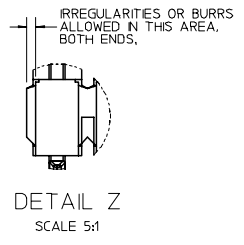
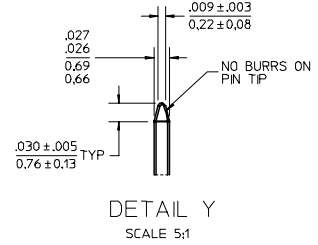
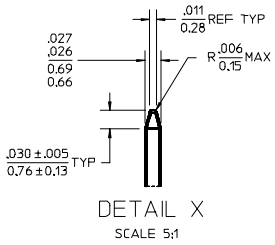

- NOTES:
- MATERIAL: GLASS FILLED NYLON, 94V-0, COLOR: BLACK
 - FINISH:
 - (154) *OVERALL TIN: .000100/0.00254 MIN. OVER .000050/0.00127 MIN NICKEL.
 - (208) SELECT GOLD: .000015/0.00038 MIN. *SELECT TIN: .000100/0.00254 MIN. OVERALL NICKEL UNDERPLATE: .000050/0.00127 MIN.
 - (228) SELECT GOLD: .000030/0.00076 MIN. *SELECT TIN: .000100/0.00254 MIN. OVERALL NICKEL UNDERPLATE: .000050/0.00127 MIN.
 - THE PRIMARY SHIPPING CARTON WILL BE LABELED "COMPLIANT TO RoHS DIRECTIVE 2002/95/EC AND ELV ANNEX II OF DIRECTIVE 2000/53/EC". CARTONS WITHOUT THIS LABEL MAY CONTAIN PRODUCT WITH TIN-LEAD PLATING
 - PRODUCT SPECIFICATION: PS-10-07.
 - PACKAGING INFORMATION: SEE TABLES
 - KINK PIN SPECIFICATION: SEE SMES-42003
 - HEADERS ARE NOT STACKABLE ON .100/2.54 CENTERS.
 - SOLDERABILITY PER SMES-152.
 - PN PUSH OUT FORCE: 3 LBS. MIN.
 - ABRASION MARKS ON BACK WALL SURFACE ARE PERMISSIBLE.

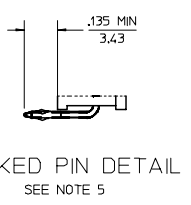
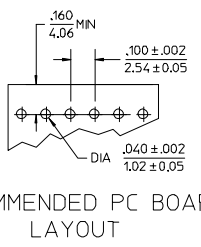

| REV | DESCRIPTION |
|-----|---|
| L4 | ADD NOTE 9 EC NO: UCP2006-1710 DRWN: ADERR 2006/02/01 CHKD: LSCHM1DT 2006/02/02 APPR: FSWJTH 2006/02/06 |

| QUALITY SYMBOLS | GENERAL TOLERANCES (UNLESS SPECIFIED) | |
|-----------------|---------------------------------------|--------|
| | mm | INCH |
| ▽=0 | 4 PLACES ± --- | ± --- |
| ▽=0 | 3 PLACES ± --- | ± .010 |
| | 2 PLACES ± 0.25 | ± .014 |
| | 1 PLACE ± 0.36 | ± --- |
| | ANGULAR ± 1/2° | |

| DIMENSION STYLE | |
|------------------------|------------|
| IN/MM | DATE |
| DRAWN BY JSCHAFFER | 2004/03/18 |
| CHECKED BY KSAMIEC | 2004/03/18 |
| APPROVED BY MARGULIS | 2004/03/18 |
| MATERIAL NO. SEE CHART | |

| SCALE | DESIGN UNITS | THIRD ANGLE PROJECTION |
|---|--------------|------------------------|
| 2:1 | INCH | ☉ |
| .100 FRICTION LOCK BREAKAWAY HEADER ASSY | | |
| MOLEX MOLEX INCORPORATED | | |
| MATERIAL NO. SD-42228-001 | DOCUMENT NO. | SHEET NO. 1 OF 4 |
| DRAFT WHERE APPLICABLE MUST REMAIN WITHIN DIMENSIONS | | |
| THIS DRAWING CONTAINS INFORMATION THAT IS PROPRIETARY TO MOLEX INCORPORATED AND SHOULD NOT BE USED WITHOUT WRITTEN PERMISSION | | |

| | | | | | | | | | | | |
|-------------------|--|--|--|--|--|-------------------|--|--|--|--|--|
| A-42228-0002/0036 | | | | | | A-42228-0037/0071 | | | | | |
|-------------------|--|--|--|--|--|-------------------|--|--|--|--|--|

| | |
|--------------------|-----------------|
| HEADER NUMBER: | 41411 |
| PIN NUMBER: | 42663-CKA154 |
| PIN LENGTH: L | .705/17.91 |
| MATING LENGTH: M | .295/7.49 |
| GOLD POINT: G | N/A |
| PC TAIL LENGTH: P | .120/3.05 |
| TIN: T | OVERALL |
| DIMENSION Y | .022/0.56 |
| CKTS: | 2-36 |
| KINKS: | NO |
| REMOVED BACKWALLS: | NO |
| VOIDED CKTS: | NONE |
| PACKAGING: | BULK 40873-0056 |

| | |
|--------------------|-----------------|
| HEADER NUMBER: | 41411 |
| PIN NUMBER: | 42663-CKB208 |
| PIN LENGTH: L | .705/17.91 |
| MATING LENGTH: M | .295/7.49 |
| GOLD POINT: G | .140/3.56 |
| PC TAIL LENGTH: P | .120/3.05 |
| TIN: T | .135/3.43 |
| DIMENSION Y | .022/0.56 |
| CKTS: | 2-36 |
| KINKS: | NO |
| REMOVED BACKWALLS: | NO |
| VOIDED CKTS: | NONE |
| PACKAGING: | BULK 40873-0056 |

| CKTS | MATERIAL NUMBER | ENG NUMBER | CKTS | MATERIAL NUMBER | ENG NUMBER |
|------|-----------------|--------------|------|-----------------|--------------|
| 02 | 22-28-1020 | A-42228-0002 | 20 | 22-28-1200 | A-42228-0020 |
| 03 | 22-28-1030 | A-42228-0003 | 21 | 22-28-1210 | A-42228-0021 |
| 04 | 22-28-1040 | A-42228-0004 | 22 | 22-28-1220 | A-42228-0022 |
| 05 | 22-28-1050 | A-42228-0005 | 23 | 22-28-1230 | A-42228-0023 |
| 06 | 22-28-1060 | A-42228-0006 | 24 | 22-28-1240 | A-42228-0024 |
| 07 | 22-28-1070 | A-42228-0007 | 25 | 22-28-1250 | A-42228-0025 |
| 08 | 22-28-1080 | A-42228-0008 | 26 | 22-28-1260 | A-42228-0026 |
| 09 | 22-28-1090 | A-42228-0009 | 27 | 22-28-1270 | A-42228-0027 |
| 10 | 22-28-1100 | A-42228-0010 | 28 | 22-28-1280 | A-42227-0028 |
| 11 | 22-28-1110 | A-42228-0011 | 29 | 22-28-1290 | A-42228-0029 |
| 12 | 22-28-1120 | A-42228-0012 | 30 | 22-28-1300 | A-42228-0030 |
| 13 | 22-28-1130 | A-42228-0013 | 31 | 22-28-1310 | A-42228-0031 |
| 14 | 22-28-1140 | A-42228-0014 | 32 | 22-28-1320 | A-42228-0032 |
| 15 | 22-28-1150 | A-42228-0015 | 33 | 22-28-1330 | A-42228-0033 |
| 16 | 22-28-1160 | A-42228-0016 | 34 | 22-28-1340 | A-42228-0034 |
| 17 | 22-28-1170 | A-42228-0017 | 35 | 22-28-1350 | A-42228-0035 |
| 18 | 22-28-1180 | A-42228-0018 | 36 | 22-28-1360 | A-42228-0036 |
| 19 | 22-28-1190 | A-42228-0019 | | | |

| CKTS | MATERIAL NUMBER | ENG NUMBER | CKTS | MATERIAL NUMBER | ENG NUMBER |
|------|-----------------|--------------|------|-----------------|--------------|
| 02 | 22-28-1021 | A-42228-0037 | 20 | 22-28-1201 | A-42228-0055 |
| 03 | 22-28-1031 | A-42228-0038 | 21 | 22-28-1211 | A-42228-0056 |
| 04 | 22-28-1041 | A-42228-0039 | 22 | 22-28-1221 | A-42228-0057 |
| 05 | 22-28-1051 | A-42228-0040 | 23 | 22-28-1231 | A-42228-0058 |
| 06 | 22-28-1061 | A-42228-0041 | 24 | 22-28-1241 | A-42228-0059 |
| 07 | 22-28-1071 | A-42228-0042 | 25 | 22-28-1251 | A-42228-0060 |
| 08 | 22-28-1081 | A-42228-0043 | 26 | 22-28-1261 | A-42228-0061 |
| 09 | 22-28-1091 | A-42228-0044 | 27 | 22-28-1271 | A-42228-0062 |
| 10 | 22-28-1101 | A-42228-0045 | 28 | 22-28-1281 | A-42228-0063 |
| 11 | 22-28-1111 | A-42228-0046 | 29 | 22-28-1291 | A-42228-0064 |
| 12 | 22-28-1121 | A-42228-0047 | 30 | 22-28-1301 | A-42228-0065 |
| 13 | 22-28-1131 | A-42228-0048 | 31 | 22-28-1311 | A-42228-0066 |
| 14 | 22-28-1141 | A-42228-0049 | 32 | 22-28-1321 | A-42228-0067 |
| 15 | 22-28-1151 | A-42228-0050 | 33 | 22-28-1331 | A-42228-0068 |
| 16 | 22-28-1161 | A-42228-0051 | 34 | 22-28-1341 | A-42228-0069 |
| 17 | 22-28-1171 | A-42228-0052 | 35 | 22-28-1351 | A-42228-0070 |
| 18 | 22-28-1181 | A-42228-0053 | 36 | 22-28-1361 | A-42228-0071 |
| 19 | 22-28-1191 | A-42228-0054 | | | |

| | | |
|------------------|--|---------------------------|
| REV: L | TITLE: .100 FRICTION LOCK BREAKAWAY HEADER ASSY. | SHEET No. - 2 - |
|------------------|--|---------------------------|

| | | | |
|---|---|---|---|
| DOCUMENT NUMBER: SD- 42228 -001 | CREATED / REVISED BY: S. LINEHAN 03/04/2004 | CHECKED BY: K.SAMIEC 03/04/2004 | APPROVED BY: Y. MARGULIS 03/04/2004 |
|---|---|---|---|

| A-42228-0072/0106 | | | | | | A-42228-0107/0141 | | | | | |
|--------------------|-----------------|-----------------|------|-----------------|--------------|--------------------|-----------------|-----------------|------|-----------------|--------------|
| HEADER NUMBER: | | 41411 | | | | HEADER NUMBER: | | 41411 | | | |
| PIN NUMBER: | | 42663-CKB228 | | | | PIN NUMBER: | | 42663-CNA154 | | | |
| PIN LENGTH: L | | .705/17.91 | | | | PIN LENGTH: L | | .720/18.29 | | | |
| MATING LENGTH: M | | .295/7.49 | | | | MATING LENGTH: M | | .295/7.49 | | | |
| GOLD POINT: G | | .140/3.56 | | | | GOLD POINT: G | | N/A | | | |
| PC TAIL LENGTH: P | | .120/3.05 | | | | PC TAIL LENGTH: P | | .135/3.43 | | | |
| TIN: T | | .135/3.43 | | | | TIN: T | | OVERALL | | | |
| DIMENSION Y | | .022/0.56 | | | | DIMENSION Y | | .022/0.56 | | | |
| CKTS: | | 2-36 | | | | CKTS: | | 2-36 | | | |
| KINKS: | | NO | | | | KINKS: | | YES ES-42003 | | | |
| REMOVED BACKWALLS: | | NO | | | | REMOVED BACKWALLS: | | NO | | | |
| VOIDED CKTS: | | NONE | | | | VOIDED CKTS: | | NONE | | | |
| PACKAGING: | | BULK 40873-0056 | | | | PACKAGING: | | BULK 40873-0056 | | | |
| CKTS | MATERIAL NUMBER | ENG NUMBER | CKTS | MATERIAL NUMBER | ENG NUMBER | CKTS | MATERIAL NUMBER | ENG NUMBER | CKTS | MATERIAL NUMBER | ENG NUMBER |
| 02 | 22-28-1022 | A-42228-0072 | 20 | 22-28-1202 | A-42228-0090 | 02 | 22-28-1023 | A-42228-0107 | 20 | 22-28-1203 | A-42228-0125 |
| 03 | 22-28-1032 | A-42228-0073 | 21 | 22-28-1212 | A-42228-0091 | 03 | 22-28-1033 | A-42228-0108 | 21 | 22-28-1213 | A-42228-0126 |
| 04 | 22-28-1042 | A-42228-0074 | 22 | 22-28-1222 | A-42228-0092 | 04 | 22-28-1043 | A-42228-0109 | 22 | 22-28-1223 | A-42228-0127 |
| 05 | 22-28-1052 | A-42228-0075 | 23 | 22-28-1232 | A-42228-0093 | 05 | 22-28-1053 | A-42228-0110 | 23 | 22-28-2233 | A-42228-0128 |
| 06 | 22-28-1062 | A-42228-0076 | 24 | 22-28-1242 | A-42228-0094 | 06 | 22-28-1063 | A-42228-0111 | 24 | 22-28-1243 | A-42228-0129 |
| 07 | 22-28-1072 | A-42228-0077 | 25 | 22-28-1252 | A-42228-0095 | 07 | 22-28-1073 | A-42228-0112 | 25 | 22-28-1253 | A-42228-0130 |
| 08 | 22-28-1082 | A-42228-0078 | 26 | 22-28-1262 | A-42228-0096 | 08 | 22-28-1083 | A-42228-0113 | 26 | 22-28-1263 | A-42228-0131 |
| 09 | 22-28-1092 | A-42228-0079 | 27 | 22-28-1272 | A-42228-0097 | 09 | 22-28-1093 | A-42228-0114 | 27 | 22-28-1273 | A-42228-0132 |
| 10 | 22-28-1102 | A-42228-0080 | 28 | 22-28-1282 | A-42228-0098 | 10 | 22-28-1103 | A-42228-0115 | 28 | 22-28-1283 | A-42228-0133 |
| 11 | 22-28-1112 | A-42228-0081 | 29 | 22-28-1292 | A-42228-0099 | 11 | 22-28-1113 | A-42228-0116 | 29 | 22-28-1293 | A-42228-0134 |
| 12 | 22-28-1122 | A-42228-0082 | 30 | 22-28-1302 | A-42228-0100 | 12 | 22-28-1123 | A-42228-0117 | 30 | 22-28-1303 | A-42228-0135 |
| 13 | 22-28-1132 | A-42228-0083 | 31 | 22-28-1312 | A-42228-0101 | 13 | 22-28-1133 | A-42228-0118 | 31 | 22-28-1313 | A-42228-0136 |
| 14 | 22-28-1142 | A-42228-0084 | 32 | 22-28-1322 | A-42228-0102 | 14 | 22-28-1143 | A-42228-0119 | 32 | 22-28-1323 | A-42228-0137 |
| 15 | 22-28-1152 | A-42228-0085 | 33 | 22-28-1332 | A-42228-0103 | 15 | 22-28-1153 | A-42228-0120 | 33 | 22-28-1333 | A-42228-0138 |
| 16 | 22-28-1162 | A-42228-0086 | 34 | 22-28-1342 | A-42228-0104 | 16 | 22-28-1163 | A-42228-0121 | 34 | 22-28-1343 | A-42228-0139 |
| 17 | 22-28-1172 | A-42228-0087 | 35 | 22-28-1352 | A-42228-0105 | 17 | 22-28-1173 | A-42228-0122 | 35 | 22-28-1353 | A-42228-0140 |
| 18 | 22-28-1182 | A-42228-0088 | 36 | 22-28-1362 | A-42228-0106 | 18 | 22-28-1183 | A-42228-0123 | 36 | 22-28-1363 | A-42228-0141 |
| 19 | 22-28-1192 | A-42228-0089 | | | | 19 | 22-28-1193 | A-42228-0124 | | | |

| | | | | | |
|-----------------------|--|------------------------------|--|-------------------------------|--------------|
| REV: | | TITLE: | .100 FRICTION LOCK BREAKAWAY HEADER ASSY. | | SHEET No. |
| L | | | | | - 3 - |
| DOCUMENT NUMBER: | | CREATED / REVISED BY: | CHECKED BY: | APPROVED BY: | |
| SD- 42228 -001 | | S. LINEHAN 03/04/2004 | K.SAMIEC 03/04/2004 | Y. MARGULIS 03/04/2004 | |

| | | | | | | | | | | | |
|--|--|--|--|--|--|--|--|--|--|--|--|
| | | | | | | | | | | | |
|--|--|--|--|--|--|--|--|--|--|--|--|

| A-42228-0142/0176 | | | | | |
|--------------------|-----------------|-----------------|------|-----------------|--------------|
| HEADER NUMBER: | | 41411 | | | |
| PIN NUMBER: | | 42663-CNB208 | | | |
| PIN LENGTH: L | | .720/18.29 | | | |
| MATING LENGTH: M | | .295/7.49 | | | |
| GOLD POINT: G | | .140/3.56 | | | |
| PC TAIL LENGTH: P | | .135/3.43 | | | |
| TIN: T | | .135/3.43 | | | |
| DIMENSION Y | | .022/0.56 | | | |
| CKTS: | | 2-36 | | | |
| KINKS: | | YES ES-42003 | | | |
| REMOVED BACKWALLS: | | NO | | | |
| VOIDED CKTS: | | NONE | | | |
| PACKAGING: | | BULK 40873-0056 | | | |
| CKTS | MATERIAL NUMBER | ENG NUMBER | CKTS | MATERIAL NUMBER | ENG NUMBER |
| 02 | 22-28-1024 | A-42228-0142 | 20 | 22-28-1204 | A-42228-0160 |
| 03 | 22-28-1034 | A-42228-0143 | 21 | 22-28-1214 | A-42228-0161 |
| 04 | 22-28-1044 | A-42228-0144 | 22 | 22-28-1224 | A-42228-0162 |
| 05 | 22-28-1054 | A-42228-0145 | 23 | 22-28-1234 | A-42228-0163 |
| 06 | 22-28-1064 | A-42228-0146 | 24 | 22-28-1244 | A-42228-0164 |
| 07 | 22-28-1074 | A-42228-0147 | 25 | 22-28-1254 | A-42228-0165 |
| 08 | 22-28-1084 | A-42228-0148 | 26 | 22-28-1264 | A-42228-0166 |
| 09 | 22-28-1094 | A-42228-0149 | 27 | 22-28-1274 | A-42228-0167 |
| 10 | 22-28-1104 | A-42228-0150 | 28 | 22-28-1284 | A-42228-0168 |
| 11 | 22-28-1114 | A-42228-0151 | 29 | 22-28-1294 | A-42228-0169 |
| 12 | 22-28-1124 | A-42228-0152 | 30 | 22-28-1304 | A-42228-0170 |
| 13 | 22-28-1134 | A-42228-0153 | 31 | 22-28-1314 | A-42228-0171 |
| 14 | 22-28-1144 | A-42228-0154 | 32 | 22-28-1324 | A-42228-0172 |
| 15 | 22-28-1154 | A-42228-0155 | 33 | 22-28-1334 | A-42228-0173 |
| 16 | 22-28-1164 | A-42228-0156 | 34 | 22-28-1344 | A-42228-0174 |
| 17 | 22-28-1174 | A-42228-0157 | 35 | 22-28-1354 | A-42228-0175 |
| 18 | 22-28-1184 | A-42228-0158 | 36 | 22-28-1364 | A-42228-0176 |
| 19 | 22-28-1194 | A-42228-0159 | | | |

| A-42228-0177/0211 | | | | | |
|--------------------|-----------------|-----------------|------|-----------------|--------------|
| HEADER NUMBER: | | 41411 | | | |
| PIN NUMBER: | | 42663-CNB228 | | | |
| PIN LENGTH: L | | .720/18.29 | | | |
| MATING LENGTH: M | | .295/7.49 | | | |
| GOLD POINT: G | | .140/3.56 | | | |
| PC TAIL LENGTH: P | | .135/3.43 | | | |
| TIN: T | | .135/3.43 | | | |
| DIMENSION Y | | .022/0.56 | | | |
| CKTS: | | 2-36 | | | |
| KINKS: | | YES ES-42003 | | | |
| REMOVED BACKWALLS: | | NO | | | |
| VOIDED CKTS: | | NONE | | | |
| PACKAGING: | | BULK 40873-0056 | | | |
| CKTS | MATERIAL NUMBER | ENG NUMBER | CKTS | MATERIAL NUMBER | ENG NUMBER |
| 02 | 22-28-1025 | A-42228-0177 | 20 | 22-28-1205 | A-42228-0195 |
| 03 | 22-28-1035 | A-42228-0178 | 21 | 22-28-1215 | A-42228-0196 |
| 04 | 22-28-1045 | A-42228-0179 | 22 | 22-28-1225 | A-42228-0197 |
| 05 | 22-28-1055 | A-42228-0180 | 23 | 22-28-2235 | A-42228-0198 |
| 06 | 22-28-1065 | A-42228-0181 | 24 | 22-28-1245 | A-42228-0199 |
| 07 | 22-28-1075 | A-42228-0182 | 25 | 22-28-1255 | A-42228-0200 |
| 08 | 22-28-1085 | A-42228-0183 | 26 | 22-28-1265 | A-42228-0201 |
| 09 | 22-28-1095 | A-42228-0184 | 27 | 22-28-1275 | A-42228-0202 |
| 10 | 22-28-1105 | A-42228-0185 | 28 | 22-28-1285 | A-42228-0203 |
| 11 | 22-28-1115 | A-42228-0186 | 29 | 22-28-1295 | A-42228-0204 |
| 12 | 22-28-1125 | A-42228-0187 | 30 | 22-28-1305 | A-42228-0205 |
| 13 | 22-28-1135 | A-42228-0188 | 31 | 22-28-1315 | A-42228-0206 |
| 14 | 22-28-1145 | A-42228-0189 | 32 | 22-28-1325 | A-42228-0207 |
| 15 | 22-28-1155 | A-42228-0190 | 33 | 22-28-1335 | A-42228-0208 |
| 16 | 22-28-1165 | A-42228-0191 | 34 | 22-28-1345 | A-42228-0209 |
| 17 | 22-28-1175 | A-42228-0192 | 35 | 22-28-1355 | A-42228-0210 |
| 18 | 22-28-1185 | A-42228-0193 | 36 | 22-28-1365 | A-42228-0211 |
| 19 | 22-28-1195 | A-42228-0194 | | | |

| | | | | | |
|----------|--|--------|--|--|--------------|
| REV: | | TITLE: | .100 FRICTION LOCK BREAKAWAY HEADER ASSY. | | SHEET No. |
| L | | | | | - 4 - |

| | | | |
|-----------------------|------------------------------|----------------------------|-------------------------------|
| DOCUMENT NUMBER: | CREATED / REVISED BY: | CHECKED BY: | APPROVED BY: |
| SD- 42228 -001 | S. LINEHAN 03/04/2004 | K.SAMIEC 03/04/2004 | Y. MARGULIS 03/04/2004 |

| CKTS | DM A | DM B |
|------|-------------|-------------|
| 2 | .200/5.08 | .100/2.54 |
| 3 | .300/7.62 | .200/5.08 |
| 4 | .400/10.16 | .300/7.62 |
| 5 | .500/12.70 | .400/10.16 |
| 6 | .600/15.24 | .500/12.70 |
| 7 | .700/17.78 | .600/15.24 |
| 8 | .800/20.32 | .700/17.78 |
| 9 | .900/22.86 | .800/20.32 |
| 10 | 1.000/25.40 | .900/22.86 |
| 11 | 1.100/27.94 | 1.000/25.40 |
| 12 | 1.200/30.48 | 1.100/27.94 |
| 13 | 1.300/33.02 | 1.200/30.48 |
| 14 | 1.400/35.56 | 1.300/33.02 |
| 15 | 1.500/38.10 | 1.400/35.56 |
| 16 | 1.600/40.64 | 1.500/38.10 |
| 17 | 1.700/43.18 | 1.600/40.64 |
| 18 | 1.800/45.72 | 1.700/43.18 |
| 19 | 1.900/48.26 | 1.800/45.72 |
| 20 | 2.000/50.80 | 1.900/48.26 |
| 21 | 2.100/53.34 | 2.000/50.80 |
| 22 | 2.200/55.88 | 2.100/53.34 |
| 23 | 2.300/58.42 | 2.200/55.88 |
| 24 | 2.400/60.96 | 2.300/58.42 |
| 25 | 2.500/63.50 | 2.400/60.96 |
| 26 | 2.600/66.04 | 2.500/63.50 |
| 27 | 2.700/68.58 | 2.600/66.04 |
| 28 | 2.800/71.12 | 2.700/68.58 |
| 29 | 2.900/73.66 | 2.800/71.12 |
| 30 | 3.000/76.20 | 2.900/73.66 |
| 31 | 3.100/78.74 | 3.000/76.20 |
| 32 | 3.200/81.28 | 3.100/78.74 |
| 33 | 3.300/83.82 | 3.200/81.28 |
| 34 | 3.400/86.36 | 3.300/83.82 |
| 35 | 3.500/88.90 | 3.400/86.36 |
| 36 | 3.600/91.44 | 3.500/88.90 |

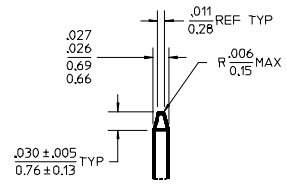

DETAIL X
SCALE 5:1

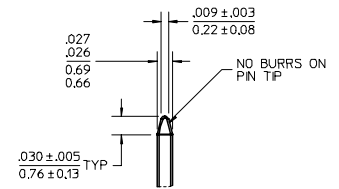

DETAIL Y
SCALE 5:1

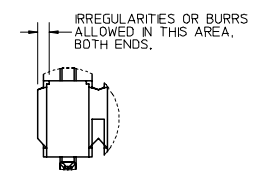

DETAIL Z
SCALE 5:1

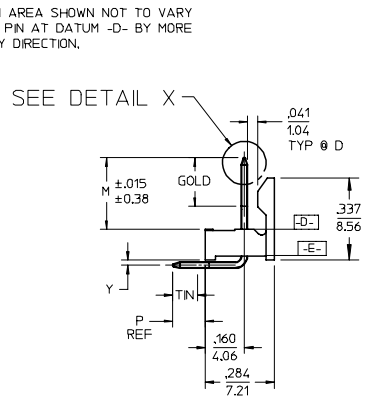
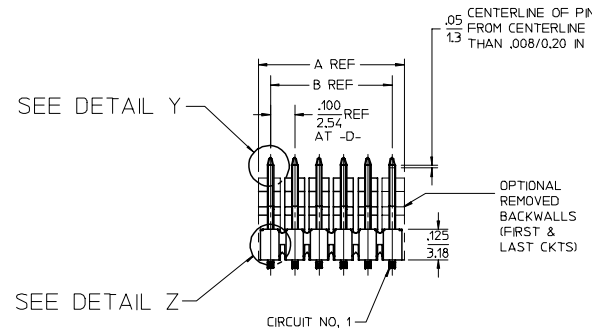
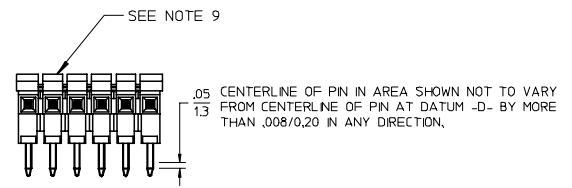
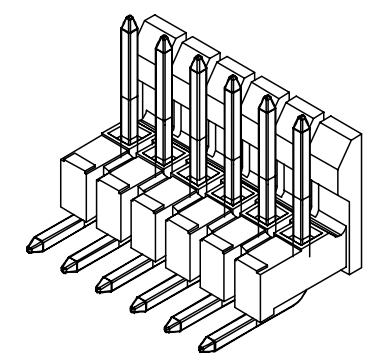

- NOTES:
 1. MATERIAL: GLASS FILLED NYLON, 94V-0, COLOR: BLACK
 2. FINISH:
 (154) *OVERALL TIN: .000100/0.00254 MIN, OVER .000050/0.00127 MN NICKEL.
 (208) SELECT GOLD: .000015/0.00038 MIN, *SELECT TIN: .000100/0.00254 MIN, OVERALL NICKEL UNDERPLATE: .000050/0.00127 MN.
 (228) SELECT GOLD: .000030/0.00076 MIN, *SELECT TIN: .000100/0.00254 MIN, OVERALL NICKEL UNDERPLATE: .000050/0.00127 MN.
 *THE PRIMARY SHIPPING CARTON WILL BE LABELED "COMPLIANT TO RoHS DIRECTIVE 2002/95/EC AND ELV ANNEX II OF DIRECTIVE 2000/53/EC". CARTONS WITHOUT THIS LABEL MAY CONTAIN PRODUCT WITH TIN-LEAD PLATING
 3. PRODUCT SPECIFICATION: PS-10-07.
 4. PACKAGING INFORMATION: SEE TABLES
 5. KINK PIN SPECIFICATION: SEE SMES-42003
 6. HEADERS ARE NOT STACKABLE ON .100/2.54 CENTERS.
 7. SOLDERABILITY PER SMES-152.
 8. PIN PUSH OUT FORCE: 3 LBS. MIN.
 9. ABRASION MARKS ON BACK WALL SURFACE ARE PERMISSIBLE.

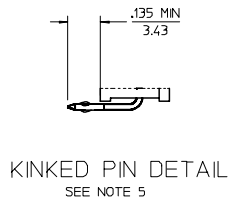
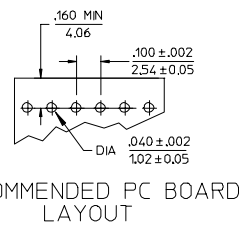

| | |
|---------------------|-------------|
| ADD NOTE 9 | DESCRIPTION |
| EC NO: UCP2006-1710 | 2006/02/01 |
| DRW: ADERR | 2006/02/02 |
| CHKD: LSCHM1DT | 2006/02/06 |
| APPR: FSWJTH | 2006/02/06 |
| REV | L4 |

| QUALITY SYMBOLS |
|-----------------|
| ▽=0 |
| ▽=0 |

| GENERAL TOLERANCES (UNLESS SPECIFIED) | |
|---------------------------------------|--------|
| | INCH |
| 4 PLACES | ± .010 |
| 3 PLACES | ± .014 |
| 2 PLACES | ± .025 |
| 1 PLACE | ± .036 |
| ANGULAR ±1/2° | |

| DIMENSION STYLE | |
|-----------------|------------|
| IN/MM | |
| DRAWN BY | DATE |
| JSCHAFFER | 2004/03/18 |
| CHECKED BY | DATE |
| KSAMIEC | 2004/03/18 |
| APPROVED BY | DATE |
| MARGULIS | 2004/03/18 |
| MATERIAL NO. | SEE CHART |

| SCALE | DESIGN UNITS | THIRD ANGLE PROJECTION |
|---|--------------|------------------------|
| 2:1 | INCH | ☉ |
| TITLE: .100 FRICTION LOCK BREAKAWAY HEADER ASSY | | |
| MATERIAL NO. MOLEX INCORPORATED | | |
| DOCUMENT NO. SD-42228-002 | | SHEET NO. 1 OF 6 |
| DRAFT WHERE APPLICABLE MUST REMAIN WITHIN DIMENSIONS | | |
| THIS DRAWING CONTAINS INFORMATION THAT IS PROPRIETARY TO MOLEX INCORPORATED AND SHOULD NOT BE USED WITHOUT WRITTEN PERMISSION | | |

| A-42228-0077 | | | | | | A-42228-0144 | | | | | |
|--------------------|-----------------|-----------------|------|-----------------|------------|--------------------|-----------------|-----------------|------|-----------------|------------|
| HEADER NUMBER: | | 41411 | | | | HEADER NUMBER: | | 41411 | | | |
| PIN NUMBER: | | 42663-CKB228 | | | | PIN NUMBER: | | 42663-CNB208 | | | |
| PIN LENGTH: L | | .705/17.91 | | | | PIN LENGTH: L | | .720/18.29 | | | |
| MATING LENGTH: M | | .295/7.49 | | | | MATING LENGTH: M | | .295/7.49 | | | |
| GOLD POINT: G | | .140/3.56 | | | | GOLD POINT: G | | .140/3.56 | | | |
| PC TAIL LENGTH: P | | .120/3.05 | | | | PC TAIL LENGTH: P | | .135/3.43 | | | |
| TIN: T | | .135/3.43 | | | | TIN: T | | .135/3.43 | | | |
| DIMENSION Y | | .022/0.56 | | | | DIMENSION Y | | .022/0.56 | | | |
| CKTS: | | 2-36 | | | | CKTS: | | 2-36 | | | |
| KINKS: | | NO | | | | KINKS: | | YES ES-42003 | | | |
| REMOVED BACKWALLS: | | NO | | | | REMOVED BACKWALLS: | | NO | | | |
| VOIDED CKTS: | | NONE | | | | VOIDED CKTS: | | NONE | | | |
| PACKAGING: | | BULK 40873-0056 | | | | PACKAGING: | | BULK 40873-0056 | | | |
| CKTS | MATERIAL NUMBER | ENG NUMBER | CKTS | MATERIAL NUMBER | ENG NUMBER | CKTS | MATERIAL NUMBER | ENG NUMBER | CKTS | MATERIAL NUMBER | ENG NUMBER |
| 02 | | | 20 | | | 02 | | | 20 | | |
| 03 | | | 21 | | | 03 | | | 21 | | |
| 04 | | | 22 | | | 04 | 50-29-1739 | A-42228-0144 | 22 | | |
| 05 | | | 23 | | | 05 | | | 23 | | |
| 06 | | | 24 | | | 06 | | | 24 | | |
| 07 | 50-29-1881 | A-42228-0077 | 25 | | | 07 | | | 25 | | |
| 08 | | | 26 | | | 08 | | | 26 | | |
| 09 | | | 27 | | | 09 | | | 27 | | |
| 10 | | | 28 | | | 10 | | | 28 | | |
| 11 | | | 29 | | | 11 | | | 29 | | |
| 12 | | | 30 | | | 12 | | | 30 | | |
| 13 | | | 31 | | | 13 | | | 31 | | |
| 14 | | | 32 | | | 14 | | | 32 | | |
| 15 | | | 33 | | | 15 | | | 33 | | |
| 16 | | | 34 | | | 16 | | | 34 | | |
| 17 | | | 35 | | | 17 | | | 35 | | |
| 18 | | | 36 | | | 18 | | | 36 | | |
| 19 | | | | | | 19 | | | | | |

| | | |
|---|--|--|
| REV: A2 | TITLE: .100 FRICTION LOCK BREAKAWAY HEADER ASSY. LEAD-FREE | SHEET No. - 2 - |
| DOCUMENT NUMBER: SD- 42228 -003 | CREATED / REVISED BY: DPETERSON 09/26/2005 | CHECKED BY: ADERR 09/26/2005 |
| | APPROVED BY: FSMITH 09/26/2005 | |