

# **A-BRIGHT** A-BRIGHT INDUSTRIAL CO., LTD. SURFACE MOUNT LED LAMPS

Power Warm White Surface Mount Device

Part Number: 62-217ASW2C1H

## Package outlines & Re-flow Profile

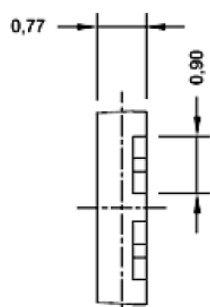
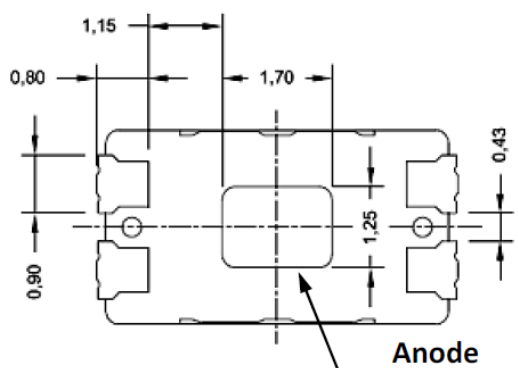
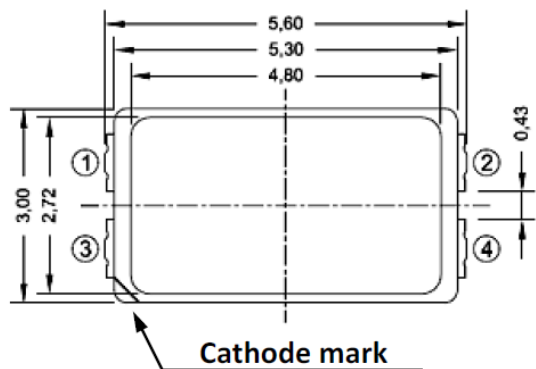

For Reflow Soldering

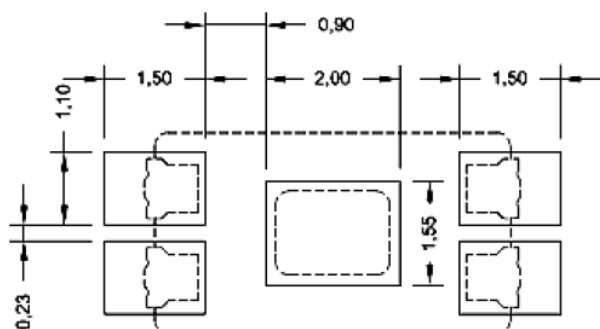

### Reflow Temp/Time

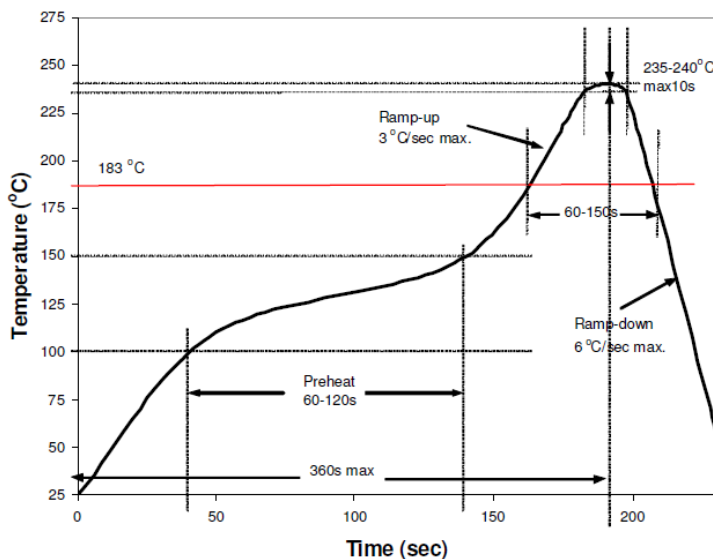

### Soldering iron

Basic spec is  $\leq 5$ sec when  $260^{\circ}\text{C}$ . If temperature is higher, time should be shorter ( $+10^{\circ}\text{C} \rightarrow -1$ sec). Power dissipation of iron should be smaller than 15W, and temperatures should be controllable. Surface temperature of the device should be under  $230^{\circ}\text{C}$ .

ITEM	MATERIALS
Resin (mold)	Epoxy
Lens color	Yellow Diffused
Printed circuit board	BT
Emitted color	Warm White
Material	InGaN

### NOTES:

1. All dimensions are in millimeters (inches);
2. Tolerances are  $\pm 0.1$ mm (0.004inch) unless otherwise noted.
3. Polarity referring onto the cathode mark is reversed on the red.

**A-BRIGHT A-BRIGHT INDUSTRIAL CO., LTD.**  
**SURFACE MOUNT LED LAMPS**

Part Number: 62-217ASW2C1H

**ELECTRO-OPTICAL CHARACTERISTICS** (T<sub>A</sub>=25°C)

Parameter	Test Condition	Symbol	Value			Unit
			MIN.	TYP.	MAX.	
Viewing angle at 50% I <sub>v</sub>	I <sub>F</sub> =60mA	2θ 1/2	120			Deg
Forward voltage	I <sub>F</sub> =60mA	V <sub>F</sub>	2.9	---	3.3	V
Luminous Flux	I <sub>F</sub> =60mA	Flux	---	23	---	Lm
Correlated Color Temperature	I <sub>F</sub> =60mA	CCT	2600	---	3700	K
Color Rendering Index	I <sub>F</sub> =60mA	CRI	---	80	---	---
Pulse Forward Current (Pulse Width ≤ 10msec, and duty ≤ 1/10)	I <sub>F</sub> =60mA	I <sub>FP</sub>	240			mA

**Absolute maximum ratings** (T<sub>A</sub>=25°C)

Parameter	Symbol	Value	Unit
Forward current	I <sub>F</sub>	120	mA
Reverse voltage	V <sub>R</sub>	5	V
Reverse current (Zener Diode)	I <sub>R</sub>	0.5	μA
Power dissipation	P <sub>D</sub>	0.4	W
Operating temperature range	Top	-40 ~+85	°C
Storage temperature range	Tstg	-40 ~+100	°C

**A-BRIGHT** A-BRIGHT INDUSTRIAL CO., LTD.  
**SURFACE MOUNT LED LAMPS**

Part Number: 62-217ASW2C1H

**Bin Range**

V <sub>F</sub> Rank	Condition	Min.	Max.
1	I <sub>F</sub> = 60 mA	2.9	3.0
2		3.0	3.1
3		3.1	3.2
4		3.2	3.3

Luminous Flux Rank	Condition	Min.	Max.
VD	I <sub>F</sub> = 60 mA	20	22.5
VE		22.5	25
VF		25	28

***A-BRIGHT*** A-BRIGHT INDUSTRIAL CO., LTD.  
**SURFACE MOUNT LED LAMPS**

Part Number: 62-217ASW2C1H

**Bin Range**

CCT	CIE Rank	CIE X	CIE Y		CIE X	CIE Y
2700	L2702	0.4562	0.426	R2702	0.4687	0.4289
		0.4499	0.4138		0.462	0.4166
		0.462	0.4166		0.474	0.4194
		0.4687	0.4289		0.481	0.4319
	L2703	0.4499	0.4138	R2703	0.462	0.4166
		0.4436	0.4015		0.4551	0.4042
		0.4551	0.4042		0.4666	0.4069
		0.462	0.4166		0.474	0.4194
	L2704	0.4436	0.4015	R2704	0.4551	0.4042
		0.4373	0.3893		0.4483	0.3919
		0.4483	0.3919		0.4593	0.3944
		0.4551	0.4042		0.4666	0.4069
3000	L3002	0.4299	0.4165	R3002	0.443	0.4212
		0.4248	0.4048		0.4374	0.4093
		0.4374	0.4093		0.4499	0.4138
		0.443	0.4212		0.4562	0.426
	L3003	0.4248	0.4048	R3003	0.4374	0.4093
		0.4198	0.3931		0.4317	0.3973
		0.4317	0.3973		0.4436	0.4015
		0.4374	0.4093		0.4374	0.4093
	L3004	0.4198	0.3931	R3004	0.4317	0.3973
		0.4147	0.3814		0.4259	0.3853
		0.4259	0.3853		0.4373	0.3893
		0.4317	0.3973		0.4436	0.4015
3500	L3502	0.3996	0.4015	R3502	0.4146	0.4089
		0.396	0.3907		0.4104	0.3978
		0.4104	0.3978		0.4248	0.4048
		0.4146	0.4089		0.4299	0.4165
	L3503	0.396	0.3907	R3503	0.4104	0.3978
		0.3925	0.3798		0.4062	0.3865
		0.4062	0.3865		0.4198	0.3931
		0.4104	0.3978		0.4248	0.4048
	L3504	0.3925	0.3798	R3504	0.4062	0.3865
		0.3889	0.369		0.4017	0.3751
		0.4017	0.3751		0.4147	0.3814
		0.4062	0.3865		0.4198	0.3931

# **A-BRIGHT** A-BRIGHT INDUSTRIAL CO., LTD. **SURFACE MOUNT LED LAMPS**

Part Number: 62-217ASW2C1H

## CIE Chromaticity Diagram

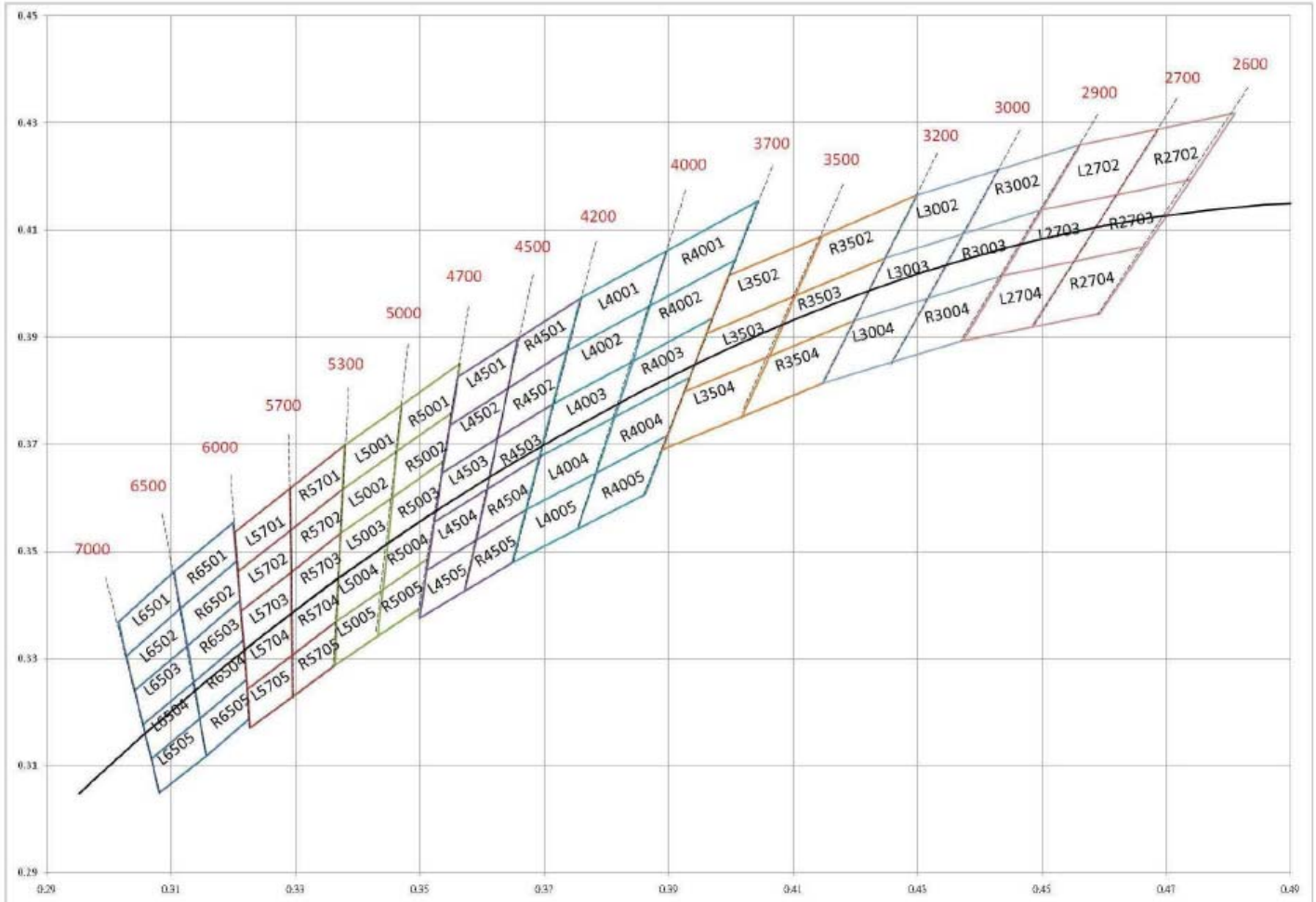

# **A-BRIGHT** A-BRIGHT INDUSTRIAL CO., LTD.

## **SURFACE MOUNT LED LAMPS**

Part Number: 62-217ASW2C1H

### Typical Electro-Optical Characteristic Curves

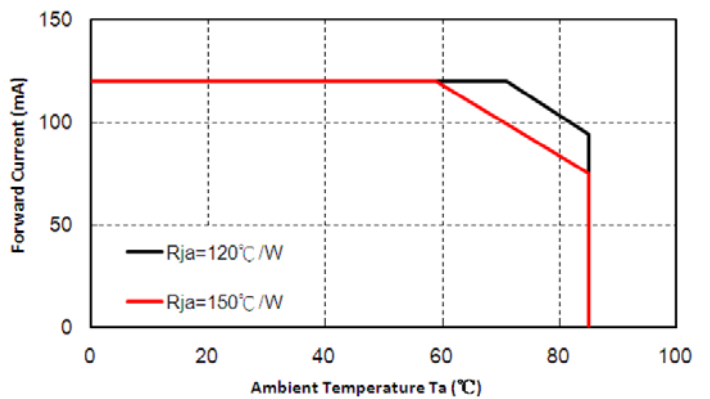
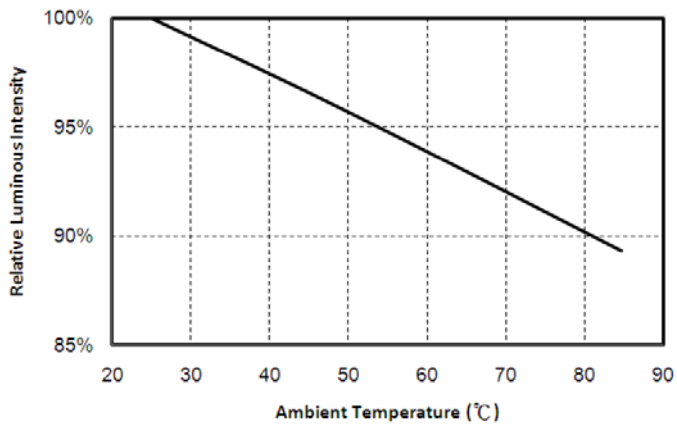
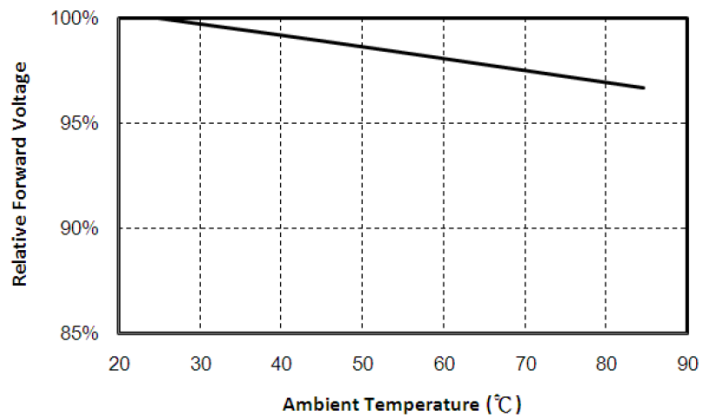
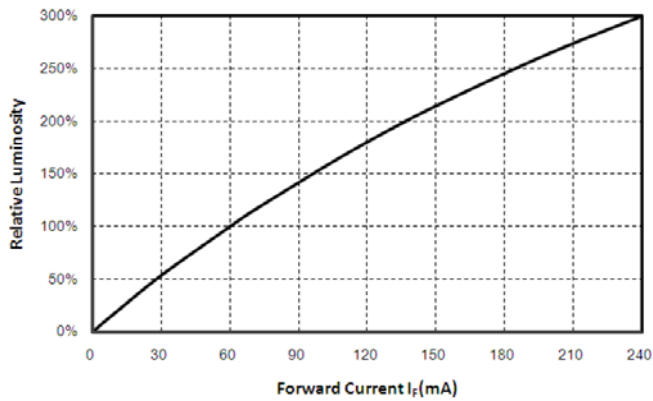
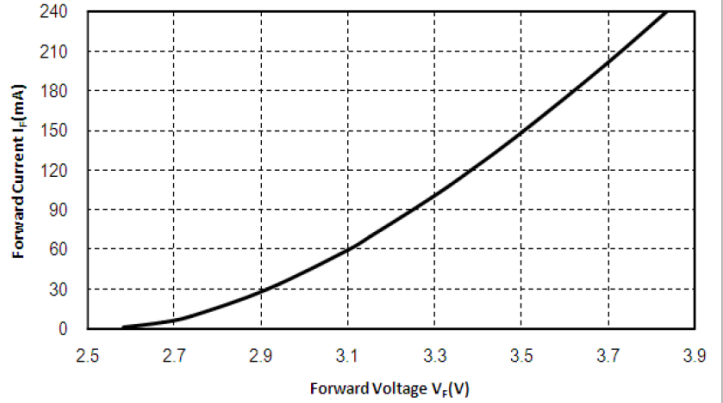
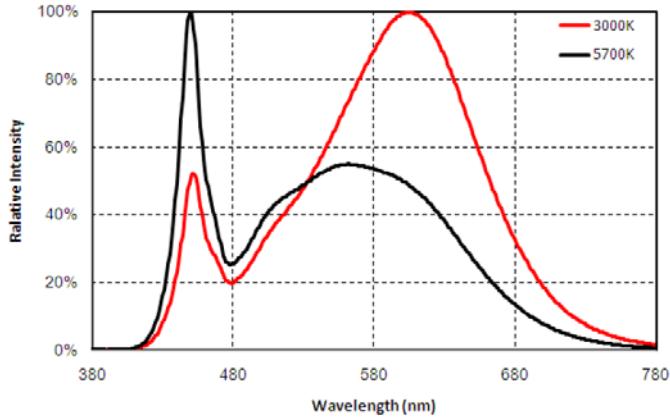

**A-BRIGHT** A-BRIGHT INDUSTRIAL CO., LTD.  
**SURFACE MOUNT LED LAMPS**

Part Number: 62-217ASW2C1H

**Typical Electro-Optical Characteristic Curves**

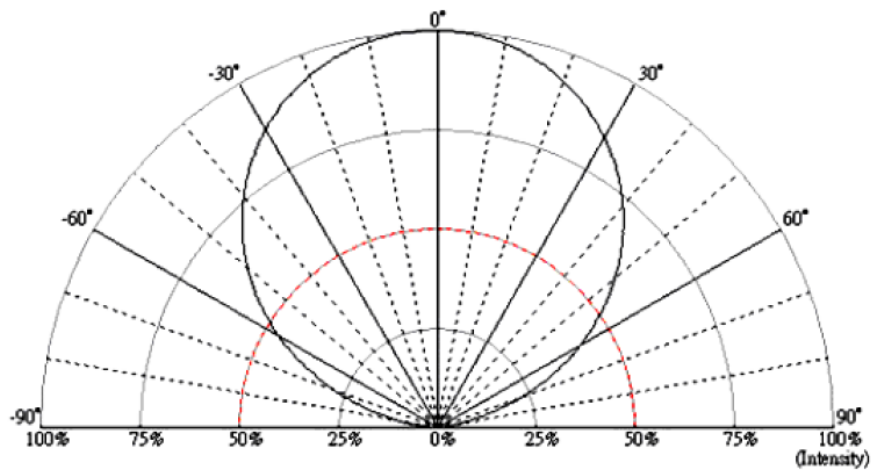
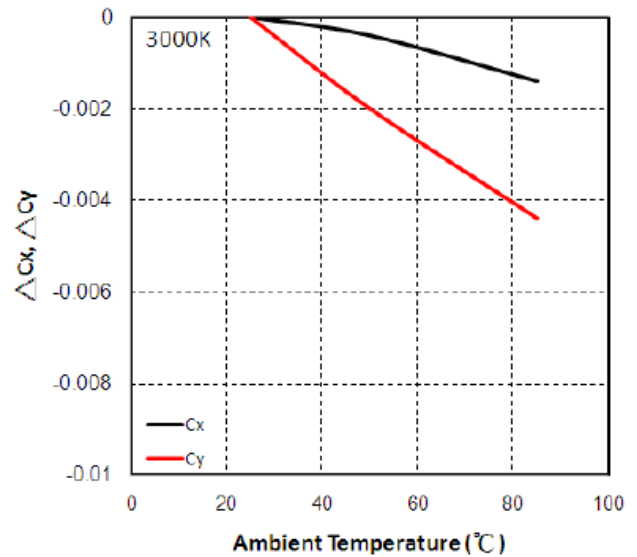
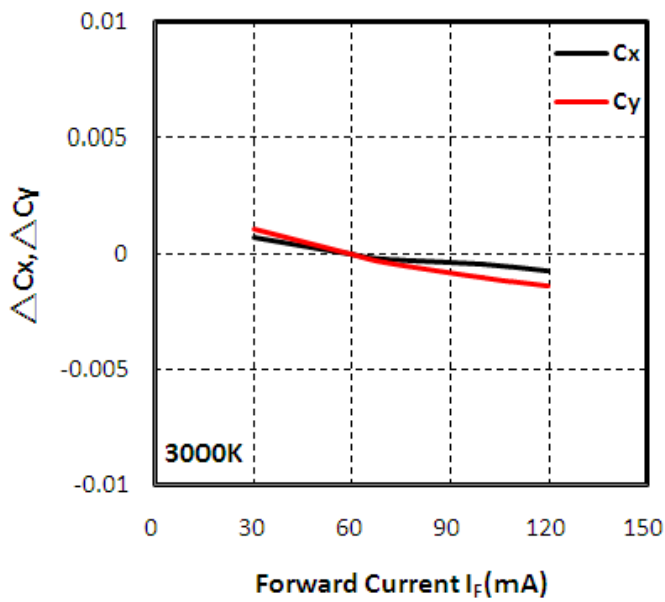

**A-BRIGHT A-BRIGHT INDUSTRIAL CO., LTD.**  
**SURFACE MOUNT LED LAMPS**

Part Number: 62-217ASW2C1H

**Reliability**

Item	Condition	Time/Cycle
Steady State Operating Life of Room Temperature	25°C Operating	1000 Hrs
Steady State Operating Life of Low Temperature -40°C	-40°C Operating	1000 Hrs
Steady State Operating Life of High Temperature 60°C	60°C Operating	1000 Hrs
Steady State Operating Life of High Temperature 85°C	85°C Operating	1000 Hrs
Low temperature storage -40°C	-40°C Storage	1000 Hrs
High temperature storage 100°C	100°C Storage	1000 Hrs
Steady State Operating Life of High Humidity Heat 60°C/90%	60°C/90% Operating	1000 Hrs
Steady State Pulse Operating Life Condition	25°C 10Hz duty=1/10 Operating	200 Cycles
Resistance to soldering heat on PCB (JEDEC MSL3)	pre-store@60°C, 60%RH for 52hrs Tslid max.=260 °C 10sec	3 Times
Heat Cycle Test (JEDEC MRC)	25°C ~ 65°C ~ -10°C, 90%RH, 24hr/1cycle	10 Cycles
Thermal shock	-40°C/20min ~5min ~ 100°C/20min	300 Cycles



# **A-BRIGHT** A-BRIGHT INDUSTRIAL CO., LTD. SURFACE MOUNT LED LAMPS

Part Number: 62-217ASW2C1H

## Package

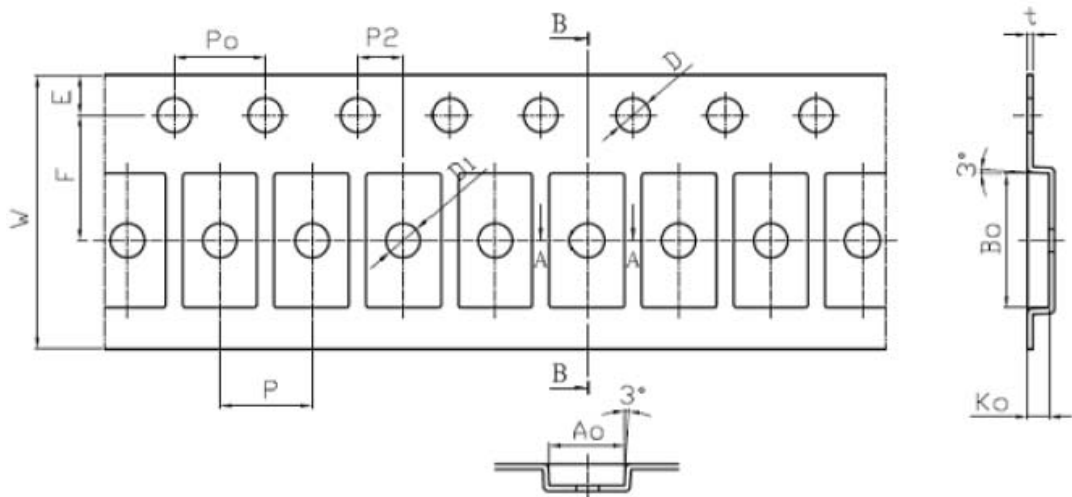
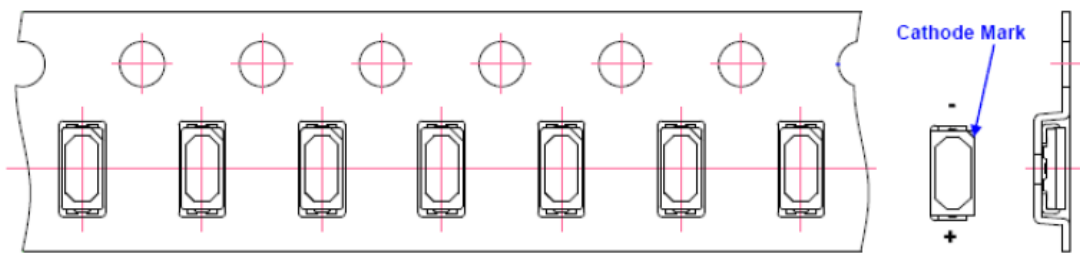
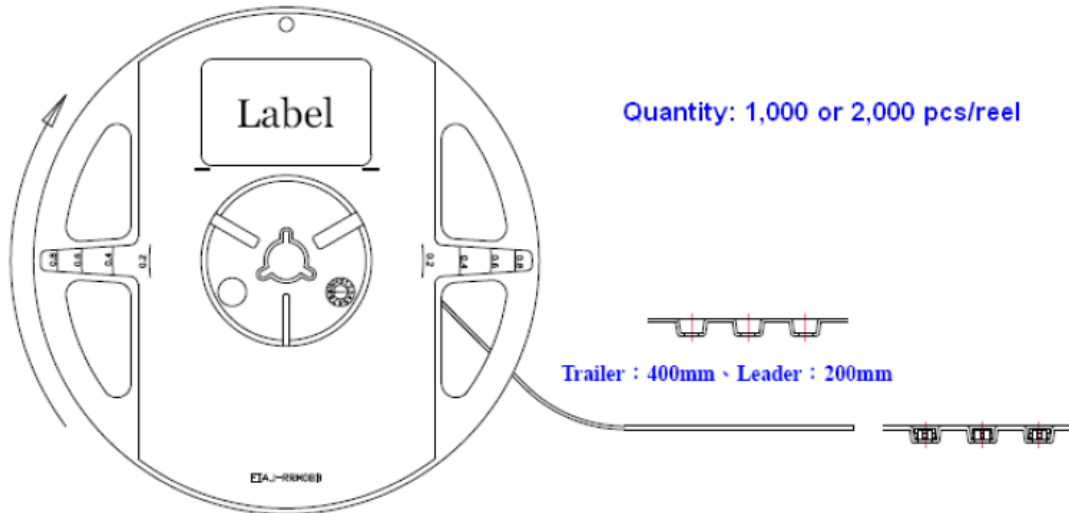

Unit: mm

Item	Spec	To1. (+/- )	Item	Spec	To1. (+/- )
W	12.00	±0.10	P2	2.00	±0.05
E	1.75	±0.10	P0 x 10	40.00	±0.20
F	5.50	±0.05	t1	0.25	±0.05
D	1.50	+0.10, -0.00	A0	3.25	±0.10
D1	1.50	±0.10	B0	5.90	±0.10
P0、P1	4.00	±0.20	K0	0.95	±0.10

# **A-BRIGHT A-BRIGHT INDUSTRIAL CO., LTD.**

## **SURFACE MOUNT LED LAMPS**

Part Number: 62-217ASW2C1H

### **Precautions For Use**

1. Over-current proof

Customer must apply resistors for protection, otherwise slight voltage shift will cause big current change (Burn out will happen).

2. Storage

2.1 Do not open moisture proof bag before the products are ready to use.

2.2 Before opening the package, the LEDs should be kept at 30°C or less and 90%RH or less.

2.3 The LEDs should be used within a year.

2.4 After opening the package, the LEDs should be kept at 30°C or less and 70%RH or less.

2.5 The LEDs should be used within 168 hours (7 days) after opening the package.

2.6 If the moisture absorbent material (silica gel) has faded away or the LEDs have exceeded the storage time, baking treatment should be performed using the following conditions.

Baking treatment : 60±5°C for 24 hours.

3. Soldering Condition

3.1 Pb-free solder temperature profile

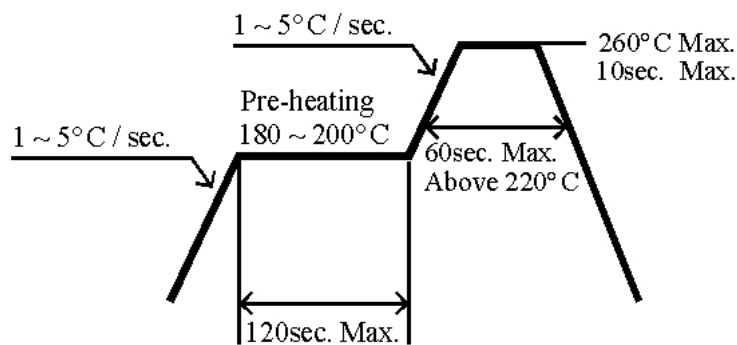

3.2 Reflow soldering should not be done more than two times.

3.3 When soldering, do not put stress on the LEDs during heating.

3.4 After soldering, do not warp the circuit board.

4. Soldering Iron

Each terminal is to go to the tip of soldering iron temperature less than 280°C for 3 seconds within once in less than soldering iron capacity 25W. Leave two seconds and more intervals, and do soldering of each terminal. Be careful because the damage of the product is often started at the time of the hand solder.