

REMOTE ACCESS IDENTIFICATION DEVICE WITH INTEGRATED 3D WAKEUP RECEIVER AND IMMOBILIZER INTERFACE

Check for Samples: [TMS37126](#)

FEATURES

- **Low-Frequency (LF) Immobilizer Interface**
 - **Integrated Batteryless Immobilizer Interface**
 - **Half Duplex (HDX) Immobilizer Communication Achieves up to 4 inch (10 cm) Read Range**
 - **Special Selective Addressing Mode Allows Reliable Learn-In Sequence**
 - **80-Bit Authentication Key Length**
 - **80-Bit DST80 Security Authentication Coprocessor**
 - **Up to 8-kbit/s Uplink Data Rate**
 - **5-/3-Byte Challenge/Response Algorithm**
 - **Fast Authentication Within 42 ms**
 - **Fast Mutual Authentication Within 65 ms**
 - **133-Byte EEPROM**
 - **91-Byte Available EEPROM User Memory**
 - **32-Bit Unique Serial Number**
 - **High EEPROM Security and Flexibility**
 - **Write-Only Authentication Keys**
 - **Pages Are Irreversibly Lockable and Protectable**
 - **Protected Pages Programmable Only Through Mutual Authentication**
 - **Battery Check and Charge Functions**
 - **Each User Page is Lockable**
 - **Resonant Frequency: 134.2 kHz**
 - **Integrated Resonant Frequency Trimming**
- **Low-Frequency 3D Wakeup Receiver**
 - **Highest Communication Range of More Than Three Meters**
 - **High Input Sensitivity: 3.7 mV_{pp} (Typ)**
 - **High Q System**
 - **Integrated Resonant Circuit Trimming Compensates for Component Offsets**
 - **Received Signal Strength Indicator (RSSI) Output for Each Channel**
 - **Resonant Circuit Usable as Clock Reference for Microcontroller (134.2 kHz)**
 - **Frequency Range: 120 kHz to 140 kHz**
 - **Ultra-Low Standby Current: 3.8 μA (Typ)**
 - **Interface to up to Three External Antennas**
 - **Two Different Programmable Wake Patterns**
 - **Selectable Wake Pattern Length: 0, 4, 8 or 16 Bits**
 - **Two Separate Adjustable Wake-Up Levels**
 - **Digital Channel Sensitivity Adjustment for Each Antenna**

DESCRIPTION

The TMS37126 Remote Access Identification Device (RAID) IC combines two functions in one device:

- 3D wakeup receiver
- DST80 immobilizer interface

The RAID has an SPI interface to connect it to an external microcontroller. RAID is ideally suited for passive entry applications. The 3D low-frequency (LF) wakeup receiver offers high sensitivity to receive LF signals between 120 kHz and 140 kHz and has several other features such as received signal strength indicator (RSSI) measurement and bidirectional LF signaling.



Please be aware that an important notice concerning availability, standard warranty, and use in critical applications of Texas Instruments semiconductor products and disclaimers thereto appears at the end of this data sheet.

The embedded DST80 immobilizer interface offers a high level of security through its hardware encryption coprocessor and can also handle mutual authentication schemes. It operates without a battery and can be accessed in terms of its memory and encryption through the SPI interface. Power management features include battery charge and check as well as a battery backup function, which allows operation of all functions with low or even no battery as long as there is sufficient energy from the LF field.

The Passive Entry (PE) device manages the immobilizer communication and LF wake reception. The special high-Q design achieves communication ranges up to 3 m for the PE link with outstanding low standby current on the receiver side. The front end offers flexible configuration of two different wake patterns of 0, 4, 8 or 16 bit length. Each channel can be adjusted in sensitivity and resonance frequency, which results in reproducible system designs. Security keys and rolling codes can be stored in the integrated EEPROM memory. This memory is accessible over the LF interface without support from the battery in the key fob and over the SPI interface. The PE device offers a special battery backup mode to operate the microcontroller without battery support. The external resonant circuit with an LF coil and a resonant capacitor can be trimmed to the correct resonant frequency with the integrated trimming capability, eliminating part tolerances.

Ordering Information⁽¹⁾

T _A	PACKAGE ⁽²⁾	ORDERABLE PART NUMBER
-40°C to 85°C	TSSOP – DBT	TMS37126D3XDBTRG4

- (1) For the most current package and ordering information, see the Package Option Addendum at the end of this document, or see the TI web site at www.ti.com.
- (2) Package drawings, thermal data, and symbolization are available at www.ti.com/packaging.

DBT PACKAGE (TOP VIEW)

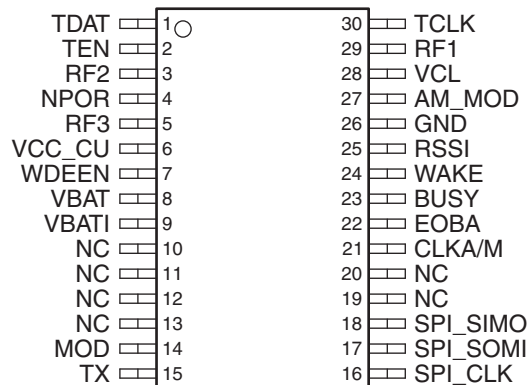

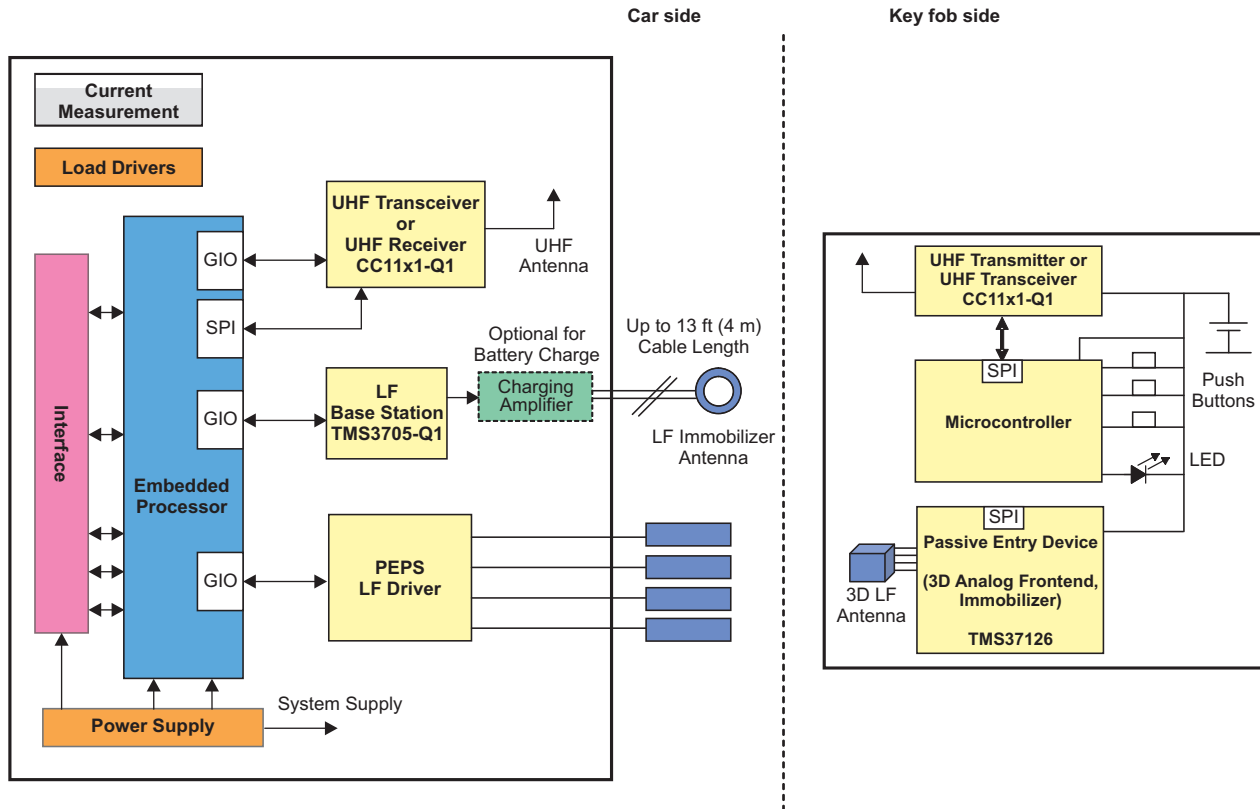

Figure 1. Application Diagram

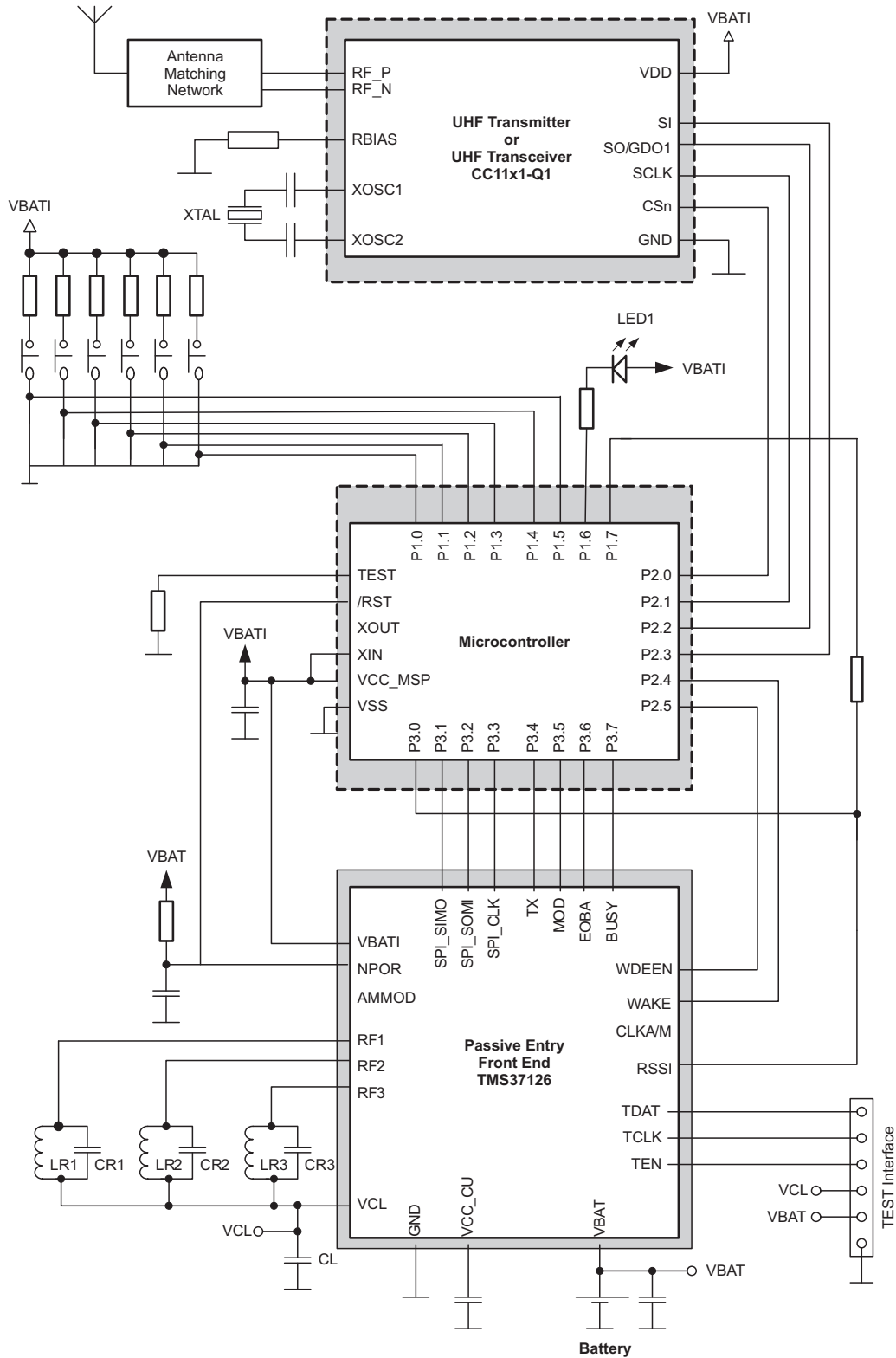

Figure 2. Application Schematic

Operating Characteristics

Part Number	TMS37126D3XDBTRG4	
Features	Immobilizer plus microcontroller with integrated power management	
DST80 authentication logic	80-bit key length, 5-byte challenge, 3-byte signature	
DST80 authentication time	Mutual authentication: 65 ms Fast authentication: 42 ms	
Supply voltage (VBAT)	1.8 V to 3.6 V	
Standby current consumption	3.8 μ A (typ) (three LF channels active)	
Transponder		
Transmission principle	HDX (half duplex telegram protocol)	
Operating frequency	134.2 kHz Integrated resonant frequency trimming capability via LF or Test interface	
Security	Challenge/response, mutual authentication	
Downlink	100% AM, PPM bit coding with 2 kbit/s (typ)	
Uplink	FSK modulation with 7.9 kbit/s (typ)	
EEPROM memory	133 bytes	91-byte free available EEPROM user memory
		32-bit unique serial number
EEPROM endurance	200 000 cycles (min) ($T_A = 25^\circ\text{C}$)	
Clock reference for microcontroller	Resonant circuit can be used as clock reference for the microcontroller	
Battery check	Two free programmable voltage levels: 2.0 V to 3.6 V with 0.1-V steps	
Battery charge	Integrated battery charge functionality	
Key learn-in	Special selective addressing to provide secure learn-in procedure	
3D Wakeup Receiver		
Sensitivity	3.7 mV _{pp} (typ)	
Sensitivity tuning	Separate for each channel and each wake pattern	
Operating frequency	120 kHz to 140 kHz	
Resonant frequency trimming	Separate for each channel	
Wake pattern	Two independent wake pattern with selectable length: 0, 4, 8 or 16 Bit	
Operating temperature	-40°C to 85°C	
Package	30-pin TSSOP (DBT)	

PACKAGING INFORMATION

Orderable Device	Status ⁽¹⁾	Package Type	Package Drawing	Pins	Package Qty	Eco Plan ⁽²⁾	Lead/ Ball Finish	MSL Peak Temp ⁽³⁾	Samples (Requires Login)
TMS37126D3XDBTRG4	ACTIVE	TSSOP	DBT	30	2000	Green (RoHS & no Sb/Br)	CU NIPDAU	Level-2-260C-1 YEAR	

⁽¹⁾ The marketing status values are defined as follows:

ACTIVE: Product device recommended for new designs.

LIFEBUY: TI has announced that the device will be discontinued, and a lifetime-buy period is in effect.

NRND: Not recommended for new designs. Device is in production to support existing customers, but TI does not recommend using this part in a new design.

PREVIEW: Device has been announced but is not in production. Samples may or may not be available.

OBSOLETE: TI has discontinued the production of the device.

⁽²⁾ Eco Plan - The planned eco-friendly classification: Pb-Free (RoHS), Pb-Free (RoHS Exempt), or Green (RoHS & no Sb/Br) - please check <http://www.ti.com/productcontent> for the latest availability information and additional product content details.

TBD: The Pb-Free/Green conversion plan has not been defined.

Pb-Free (RoHS): TI's terms "Lead-Free" or "Pb-Free" mean semiconductor products that are compatible with the current RoHS requirements for all 6 substances, including the requirement that lead not exceed 0.1% by weight in homogeneous materials. Where designed to be soldered at high temperatures, TI Pb-Free products are suitable for use in specified lead-free processes.

Pb-Free (RoHS Exempt): This component has a RoHS exemption for either 1) lead-based flip-chip solder bumps used between the die and package, or 2) lead-based die adhesive used between the die and leadframe. The component is otherwise considered Pb-Free (RoHS compatible) as defined above.

Green (RoHS & no Sb/Br): TI defines "Green" to mean Pb-Free (RoHS compatible), and free of Bromine (Br) and Antimony (Sb) based flame retardants (Br or Sb do not exceed 0.1% by weight in homogeneous material)

⁽³⁾ MSL, Peak Temp. -- The Moisture Sensitivity Level rating according to the JEDEC industry standard classifications, and peak solder temperature.

Important Information and Disclaimer: The information provided on this page represents TI's knowledge and belief as of the date that it is provided. TI bases its knowledge and belief on information provided by third parties, and makes no representation or warranty as to the accuracy of such information. Efforts are underway to better integrate information from third parties. TI has taken and continues to take reasonable steps to provide representative and accurate information but may not have conducted destructive testing or chemical analysis on incoming materials and chemicals. TI and TI suppliers consider certain information to be proprietary, and thus CAS numbers and other limited information may not be available for release.

In no event shall TI's liability arising out of such information exceed the total purchase price of the TI part(s) at issue in this document sold by TI to Customer on an annual basis.

TAPE AND REEL INFORMATION
REEL DIMENSIONS

TAPE DIMENSIONS



A0	Dimension designed to accommodate the component width
B0	Dimension designed to accommodate the component length
K0	Dimension designed to accommodate the component thickness
W	Overall width of the carrier tape
P1	Pitch between successive cavity centers

TAPE AND REEL INFORMATION

*All dimensions are nominal

Device	Package Type	Package Drawing	Pins	SPQ	Reel Diameter (mm)	Reel Width W1 (mm)	A0 (mm)	B0 (mm)	K0 (mm)	P1 (mm)	W (mm)	Pin1 Quadrant
TMS37126D3XDBTRG4	TSSOP	DBT	30	2000	330.0	16.4	6.95	8.3	1.6	8.0	16.0	Q1

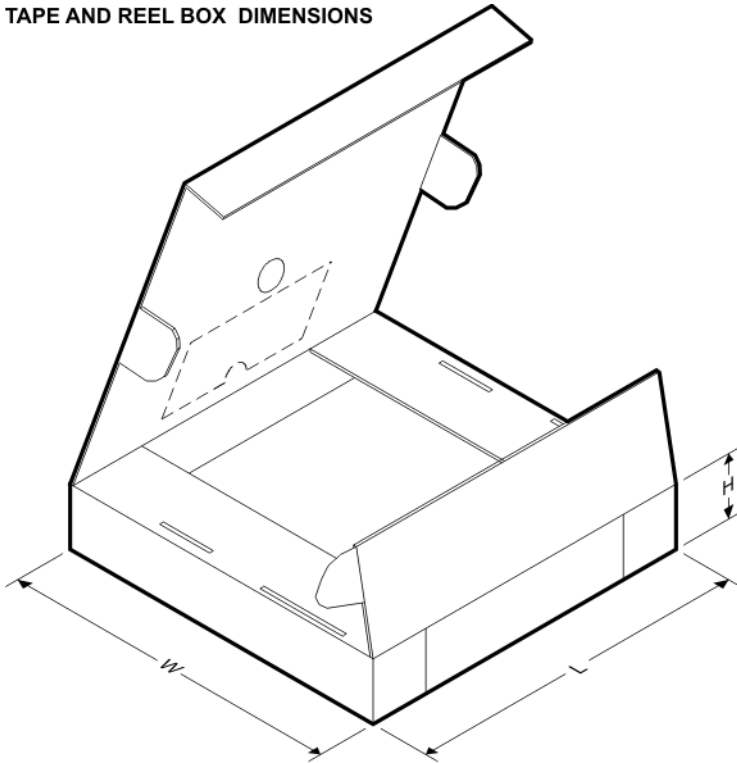
TAPE AND REEL BOX DIMENSIONS



*All dimensions are nominal

Device	Package Type	Package Drawing	Pins	SPQ	Length (mm)	Width (mm)	Height (mm)
TMS37126D3XDBTRG4	TSSOP	DBT	30	2000	367.0	367.0	38.0

DBT (R-PDSO-G30)

PLASTIC SMALL OUTLINE

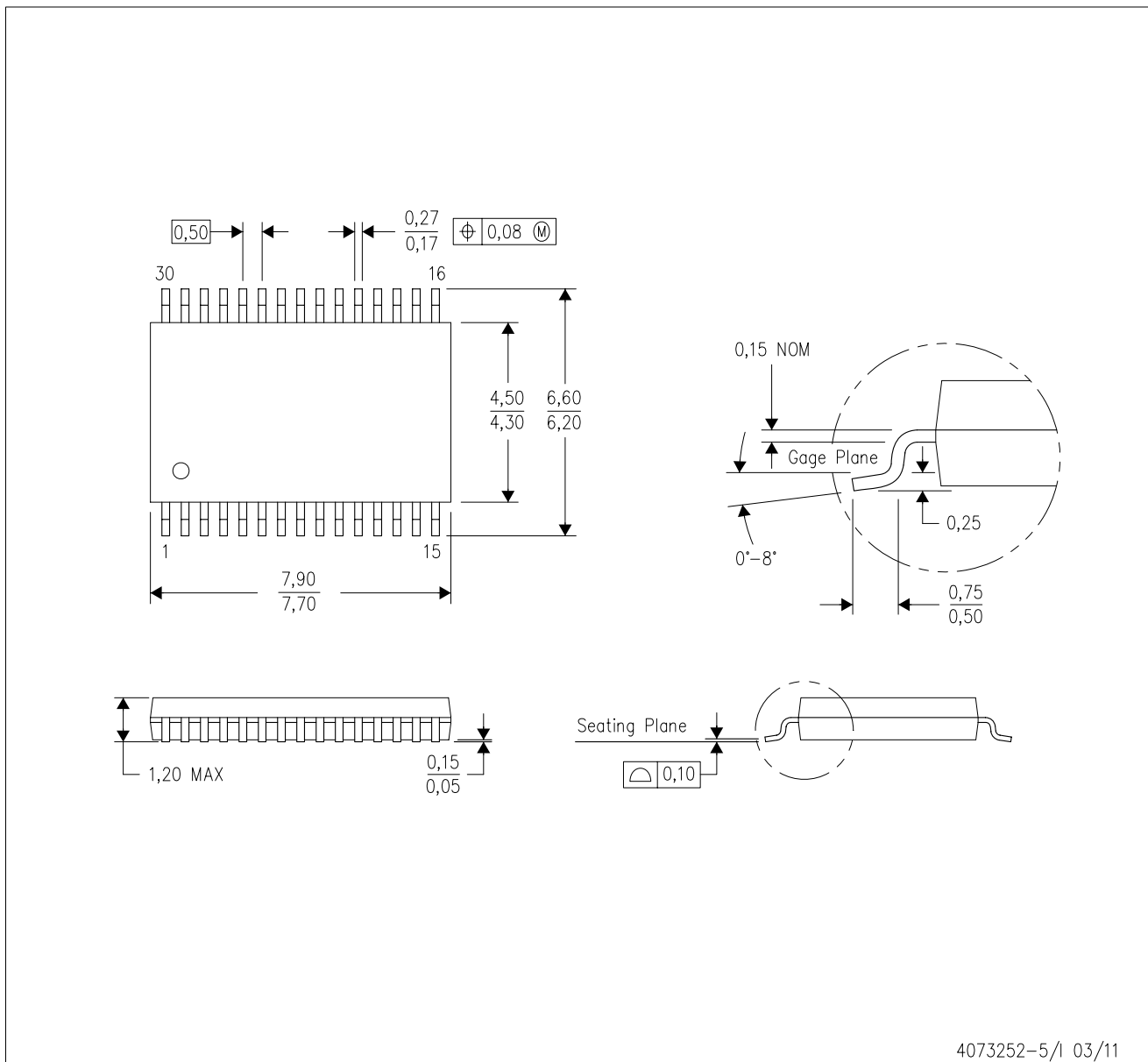

- NOTES:
- A. All linear dimensions are in millimeters. Dimensioning and tolerancing per ASME Y14.5M-1994.
 - B. This drawing is subject to change without notice.
 - C. Body dimensions do not include mold flash or protrusion.
 - D. Falls within JEDEC MO-153.

IMPORTANT NOTICE

Texas Instruments Incorporated and its subsidiaries (TI) reserve the right to make corrections, enhancements, improvements and other changes to its semiconductor products and services per JESD46C and to discontinue any product or service per JESD48B. Buyers should obtain the latest relevant information before placing orders and should verify that such information is current and complete. All semiconductor products (also referred to herein as "components") are sold subject to TI's terms and conditions of sale supplied at the time of order acknowledgment.

TI warrants performance of its components to the specifications applicable at the time of sale, in accordance with the warranty in TI's terms and conditions of sale of semiconductor products. Testing and other quality control techniques are used to the extent TI deems necessary to support this warranty. Except where mandated by applicable law, testing of all parameters of each component is not necessarily performed.

TI assumes no liability for applications assistance or the design of Buyers' products. Buyers are responsible for their products and applications using TI components. To minimize the risks associated with Buyers' products and applications, Buyers should provide adequate design and operating safeguards.

TI does not warrant or represent that any license, either express or implied, is granted under any patent right, copyright, mask work right, or other intellectual property right relating to any combination, machine, or process in which TI components or services are used. Information published by TI regarding third-party products or services does not constitute a license to use such products or services or a warranty or endorsement thereof. Use of such information may require a license from a third party under the patents or other intellectual property of the third party, or a license from TI under the patents or other intellectual property of TI.

Reproduction of significant portions of TI information in TI data books or data sheets is permissible only if reproduction is without alteration and is accompanied by all associated warranties, conditions, limitations, and notices. TI is not responsible or liable for such altered documentation. Information of third parties may be subject to additional restrictions.

Resale of TI components or services with statements different from or beyond the parameters stated by TI for that component or service voids all express and any implied warranties for the associated TI component or service and is an unfair and deceptive business practice. TI is not responsible or liable for any such statements.

Buyer acknowledges and agrees that it is solely responsible for compliance with all legal, regulatory and safety-related requirements concerning its products, and any use of TI components in its applications, notwithstanding any applications-related information or support that may be provided by TI. Buyer represents and agrees that it has all the necessary expertise to create and implement safeguards which anticipate dangerous consequences of failures, monitor failures and their consequences, lessen the likelihood of failures that might cause harm and take appropriate remedial actions. Buyer will fully indemnify TI and its representatives against any damages arising out of the use of any TI components in safety-critical applications.

In some cases, TI components may be promoted specifically to facilitate safety-related applications. With such components, TI's goal is to help enable customers to design and create their own end-product solutions that meet applicable functional safety standards and requirements. Nonetheless, such components are subject to these terms.

No TI components are authorized for use in FDA Class III (or similar life-critical medical equipment) unless authorized officers of the parties have executed a special agreement specifically governing such use.

Only those TI components which TI has specifically designated as military grade or "enhanced plastic" are designed and intended for use in military/aerospace applications or environments. Buyer acknowledges and agrees that any military or aerospace use of TI components which have **not** been so designated is solely at the Buyer's risk, and that Buyer is solely responsible for compliance with all legal and regulatory requirements in connection with such use.

TI has specifically designated certain components which meet ISO/TS16949 requirements, mainly for automotive use. Components which have not been so designated are neither designed nor intended for automotive use; and TI will not be responsible for any failure of such components to meet such requirements.

Products

Audio	www.ti.com/audio
Amplifiers	amplifier.ti.com
Data Converters	dataconverter.ti.com
DLP® Products	www.dlp.com
DSP	dsp.ti.com
Clocks and Timers	www.ti.com/clocks
Interface	interface.ti.com
Logic	logic.ti.com
Power Mgmt	power.ti.com
Microcontrollers	microcontroller.ti.com
RFID	www.ti-rfid.com
OMAP Mobile Processors	www.ti.com/omap
Wireless Connectivity	www.ti.com/wirelessconnectivity

Applications

Automotive and Transportation	www.ti.com/automotive
Communications and Telecom	www.ti.com/communications
Computers and Peripherals	www.ti.com/computers
Consumer Electronics	www.ti.com/consumer-apps
Energy and Lighting	www.ti.com/energy
Industrial	www.ti.com/industrial
Medical	www.ti.com/medical
Security	www.ti.com/security
Space, Avionics and Defense	www.ti.com/space-avionics-defense
Video and Imaging	www.ti.com/video

TI E2E Community e2e.ti.com