

FEATURES

- Ultra Low Dropout Voltage
- Low Ground Pin Current
- Excellent Line and Load Regulation
- Guaranteed Output Current of 1.5A
- Available in SOT-223, MSOP8, SOP8, SOP8-PP, TO-263, and TO-220 Packages
- Fixed Output Voltages : 1.2V, 1.8V, 2.5V, 3.3V, and 5.0V
- SENSE Option Improves Load Regulation
- Over-Temperature/Over-Current Protection
- -40°C to 125°C Junction Temperature Range

APPLICATION

- Battery Powered Equipments
- Motherboards and Graphic Cards
- Microprocessor Power Supplies
- Peripheral Cards
- High Efficiency Linear Regulators
- Battery Chargers

DESCRIPTION

The TJ3965 series of high performance ultra low-dropout linear regulators operates from 2.5V to 6V input supply and provides ultra low-dropout voltage, high output current with low ground current. Wide range of preset output voltage options are available. These ultra low dropout linear regulators respond fast to step changes in load which makes them suitable for low voltage μ processor applications. The TJ3965 is developed on a CMOS process technology which allows low quiescent current operation independent of output load current. This CMOS process also allows the TJ3965 to operate under extremely low dropout conditions.

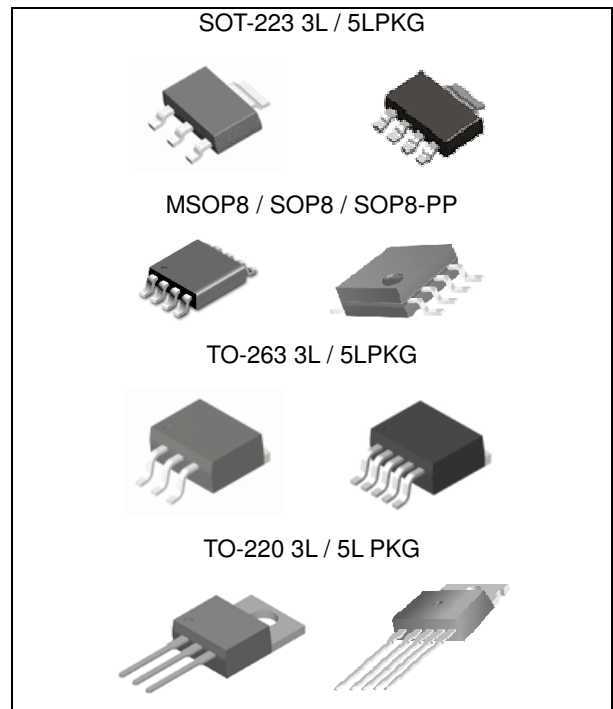

ORDERING INFORMATION

Device (Marking)	Package
3965S-ADJ	SOT-223 3L/5L
3965S-X.X	
TJ3965MD-ADJ	MSOP8
TJ3965MD-X.X	
TJ3965D-ADJ	SOP8
TJ3965D-X.X	
TJ3965DP-ADJ	SOP8-PP
TJ3965DP-X.X	
TJ3965R-ADJ	TO-263 3L/5L
TJ3965R-X.X	
TJ3965T-ADJ	TO-220 3L/5L
TJ3965T-X.X	

X.X = Output Voltage = 1.2, 1.8, 2.5, 3.3, and 5.0

Absolute Maximum Ratings

CHARACTERISTIC	SYMBOL	MIN.	MAX.	UNIT
Input Supply Voltage (Survival)	V_{IN}	-	6.5	V
Enable Input Voltage (Survival)	V_{EN}	-	6.5	V
Maximum Output Current	I_{MAX}	-	1.5	A
Lead Temperature (Soldering, 5 sec)	T_{SOL}		260	°C
Storage Temperature Range	T_{STG}	-65	150	°C
Operating Junction Temperature Range	T_{JOPR}	-40	125	°C

1.5A Ultra Low Dropout Linear Regulator

TJ3965

Ordering Information

V _{OUT}	Package	Order No.	Description	Package Marking	Supplied As
ADJ	SOT-223 5L	TJ3965S-ADJ-5L	1.5A, Adjustable, Enable	3965-ADJ	Reel
ADJ	MSOP8	TJ3965MD-ADJ-8L	1.5A, Adjustable, Enable	TJ3965-ADJ	Reel
ADJ	SOP8	TJ3965D-ADJ-8L	1.5A, Adjustable, Enable	TJ3965-ADJ	Reel
ADJ	SOP8-PP	TJ3965DP-ADJ-8L	1.5A, Adjustable, Enable	TJ3965-ADJ	Reel
ADJ	TO-263 5L	TJ3965R-ADJ-5L	1.5A, Adjustable, Enable	TJ3965-ADJ	Reel or Tube
ADJ	TO-220 5L	TJ3965T-ADJ-5L	1.5A, Adjustable, Enable	TJ3965-ADJ	Tube
1.2V	SOT-223 3L	TJ3965S-1.2V-3L	1.5A	3965-1.2	Reel
1.2V	SOT-223 5L	TJ3965S-1.2V-5L	1.5A, Enable, SENSE	3965-1.2	Reel
1.2V	MSOP8	TJ3965MD-1.2V-8L	1.5A, Enable, SENSE	TJ3965-1.2	Reel
1.2V	SOP8	TJ3965D-1.2V-8L	1.5A, Enable, SENSE	TJ3965-1.2	Reel
1.2V	SOP8-PP	TJ3965DP-1.2-8L	1.5A, Enable, SENSE	TJ3965-1.2	Reel
1.2V	TO-263 3L	TJ3965R-1.2V-3L	1.5A	TJ3965-1.2	Reel or Tube
1.2V	TO-263 5L	TJ3965R-1.2V-5L	1.5A, Enable, SENSE	TJ3965-1.2	Reel or Tube
1.2V	TO-220 3L	TJ3965T-1.2V-3L	1.5A	TJ3965-1.2	Tube
1.2V	TO-220 5L	TJ3965T-1.2V-5L	1.5A, Enable, SENSE	TJ3965-1.2	Tube
1.8V	SOT-223 3L	TJ3965S-1.8V-3L	1.5A	3965-1.8	Reel
1.8V	SOT-223 5L	TJ3965S-1.8V-5L	1.5A, Enable, SENSE	3965-1.8	Reel
1.8V	MSOP8	TJ3965MD-1.8V-8L	1.5A, Enable, SENSE	TJ3965-1.8	Reel
1.8V	SOP8	TJ3965D-1.8V-8L	1.5A, Enable, SENSE	TJ3965-1.8	Reel
1.8V	SOP8-PP	TJ3965DP-1.8V-8L	1.5A, Enable, SENSE	TJ3965-1.8	Reel
1.8V	TO -263 3L	TJ3965R-1.8V-3L	1.5A	TJ3965-1.8	Reel or Tube
1.8V	TO -263 5L	TJ3965R-1.8V-5L	1.5A, Enable, SENSE	TJ3965-1.8	Reel or Tube
1.8V	TO-220 3L	TJ3965T-1.8V-3L	1.5A	TJ3965-1.8	Tube
1.8V	TO-220 5L	TJ3965T-1.8V-5L	1.5A, Enable, SENSE	TJ3965-1.8	Tube
2.5V	SOT-223 3L	TJ3965S-2.5V-3L	1.5A	3965-2.5	Reel
2.5V	SOT-223 5L	TJ3965S-2.5V-5L	1.5A, Enable, SENSE	3965-2.5	Reel
2.5V	MSOP8	TJ3965MD-2.5V-8L	1.5A, Enable, SENSE	TJ3965-2.5	Reel
2.5V	SOP8	TJ3965D-2.5V-8L	1.5A, Enable, SENSE	TJ3965-2.5	Reel
2.5V	SOP8-PP	TJ3965DP-2.5V-8L	1.5A, Enable, SENSE	TJ3965-2.5	Reel
2.5V	TO -263 3L	TJ3965R-2.5V-3L	1.5A	TJ3965-2.5	Reel or Tube
2.5V	TO -263 5L	TJ3965R-2.5V-5L	1.5A, Enable, SENSE	TJ3965-2.5	Reel or Tube
2.5V	TO-220 3L	TJ3965T-2.5V-3L	1.5A	TJ3965-2.5	Tube
2.5V	TO-220 5L	TJ3965T-2.5V-5L	1.5A, Enable, SENSE	TJ3965-2.5	Tube

1.5A Ultra Low Dropout Linear Regulator

TJ3965

Ordering Information

(Continued)

V _{OUT}	Package	Order No.	Description	Package Marking	Supplied As
3.3V	SOT-223 3L	TJ3965S-3.3V-3L	1.5A	3965-3.3	Reel
3.3V	SOT-223 5L	TJ3965S-3.3V-5L	1.5A, Enable, SENSE	3965-3.3	Reel
3.3V	MSOP8	TJ3965MD-3.3V-8L	1.5A, Enable, SENSE	TJ3965-3.3	Reel
3.3V	SOP8	TJ3965D-3.3V-8L	1.5A, Enable, SENSE	TJ3965-3.3	Reel
3.3V	SOP8-PP	TJ3965DP-3.3V-8L	1.5A, Enable, SENSE	TJ3965-3.3	Reel
3.3V	TO -263 3L	TJ3965R-3.3V-3L	1.5A	TJ3965-3.3	Reel or Tube
3.3V	TO -263 5L	TJ3965R-3.3V-5L	1.5A, Enable, SENSE	TJ3965-3.3	Reel or Tube
3.3V	TO-220 3L	TJ3965T-3.3V-3L	1.5A	TJ3965-3.3	Tube
3.3V	TO-220 5L	TJ3965T-3.3V-5L	1.5A, Enable, SENSE	TJ3965-3.3	Tube
5.0V	SOT-223 3L	TJ3965S-5.0V-3L	1.5A	3965-5.0	Reel
5.0V	SOT-223 5L	TJ3965S-5.0V-5L	1.5A, Enable, SENSE	3965-5.0	Reel
5.0V	MSOP8	TJ3965MD-5.0V-8L	1.5A, Enable, SENSE	TJ3965-5.0	Reel
5.0V	SOP8	TJ3965D-5.0V-8L	1.5A, Enable, SENSE	TJ3965-5.0	Reel
5.0V	SOP8-PP	TJ3965DP-5.0V-8L	1.5A, Enable, SENSE	TJ3965-5.0	Reel
5.0V	TO -263 3L	TJ3965R-5.0V-3L	1.5A	TJ3965-5.0	Reel or Tube
5.0V	TO -263 5L	TJ3965R-5.0V-5L	1.5A, Enable, SENSE	TJ3965-5.0	Reel or Tube
5.0V	TO-220 3L	TJ3965T-5.0V-3L	1.5A	TJ3965-5.0	Tube
5.0V	TO-220 5L	TJ3965T-5.0V-5L	1.5A, Enable, SENSE	TJ3965-5.0	Tube

TJ3965DP-3.3V-8L

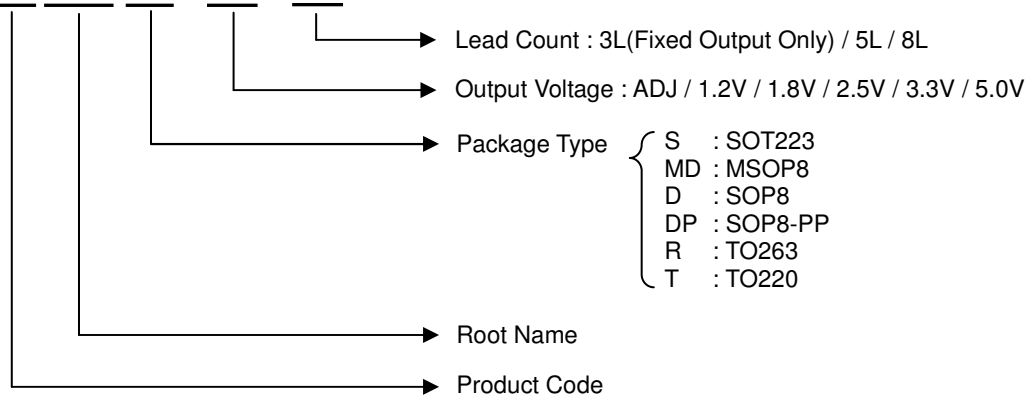

PIN CONFIGURATION

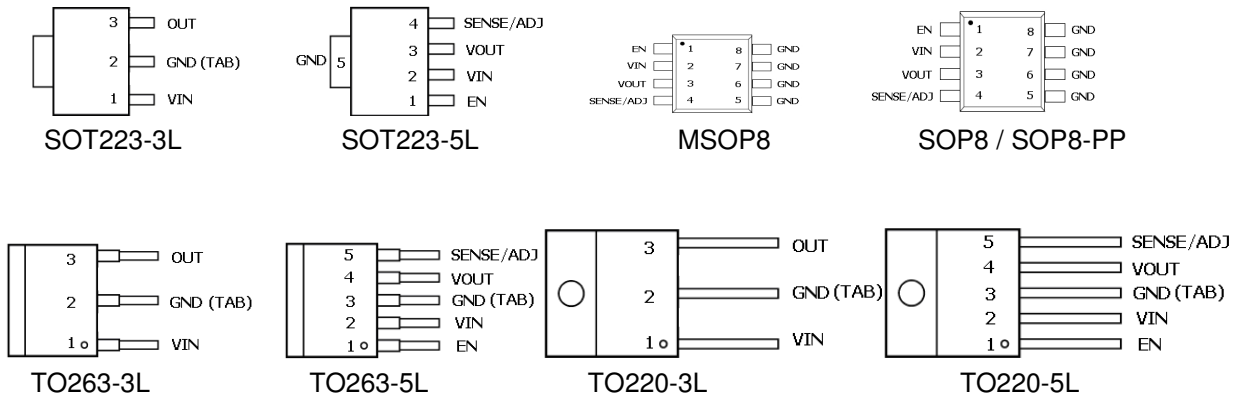

PIN DESCRIPTION

Pin No.	SOT223 / SOT263 / TO220 3 LEAD		SOT-223 5 LEAD	
	Name	Function	Name	Function
1	V_{IN}	Input Supply	EN	Chip Enable
2	GND	Ground	V_{IN}	Input Supply
3	V_{OUT}	Output Voltage	V_{OUT}	Output Voltage
4	-	-	SENSE/ADJ	Remote Sense or Output Adjust
5	-	-	GND	Ground

Pin No.	TO263 / TO220 5 LEAD		MSOP8 / SOP8 / SOP8-PP 8 LEAD	
	Name	Function	Name	Function
1	EN	Chip Enable	EN	Chip Enable
2	V_{IN}	Input Supply	V_{IN}	Input Supply
3	GND	Ground	V_{OUT}	Output Voltage
4	V_{OUT}	Output Voltage	SENSE/ADJ	Remote Sense or Output Adjust
5 / 6 / 7 / 8	SENSE/ADJ	Remote Sense or Output Adjust	GND	Ground

TYPICAL APPLICATION

Typical 3 Pin Application

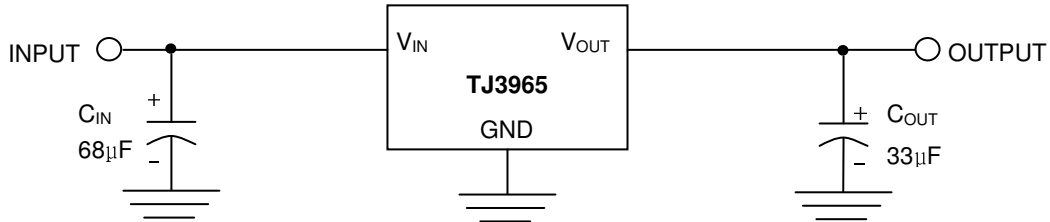

Typical 5 / 8 Pin Application

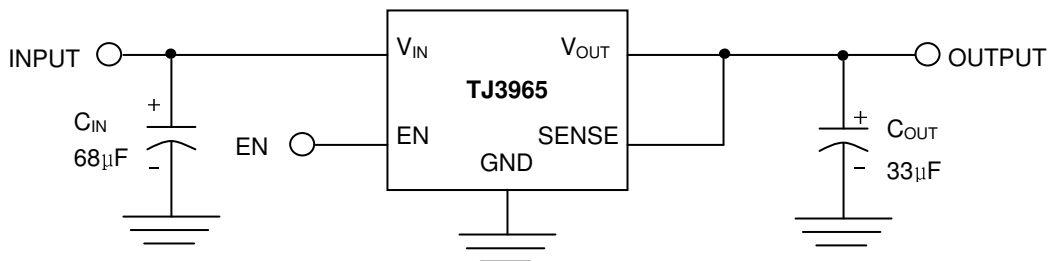

5 / 8 Pin Remote Load Sense Application

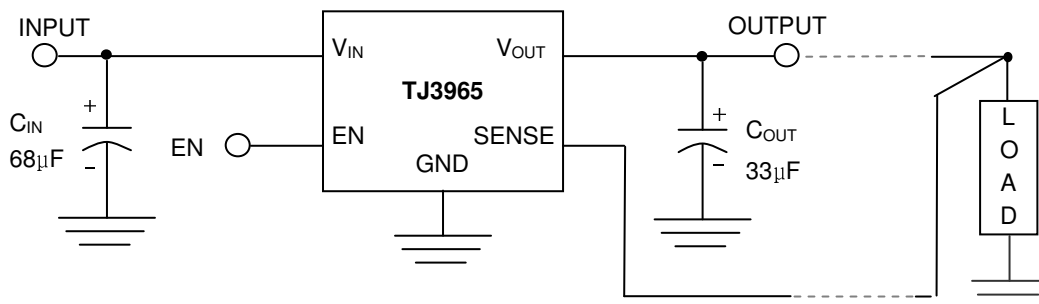

Typical Adjustable Version Application

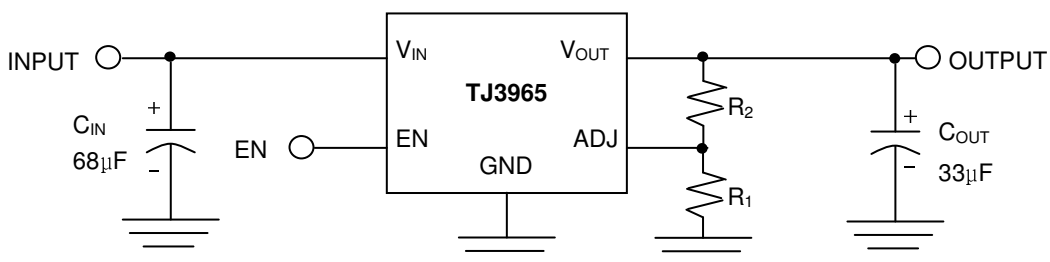

* TJ3965 can deliver a continuous current of 1.5A over the full operating temperature. However, the output current is limited by the restriction of power dissipation which differs from packages. A heat sink may be required depending on the maximum power dissipation and maximum ambient temperature of application. With respect to the applied package, the maximum output current of 1.5A may be still undeliverable.

* See Application Information

ELECTRICAL CHARACTERISTICS^(Note 1)

Limits in standard typeface are for $T_J=25^\circ\text{C}$, and limits in **boldface type** apply over the **full operating temperature range**. Unless otherwise specified: $V_{IN}^{(Note 2)} = V_{O(NOM)} + 1\text{ V}$, $I_L = 10\text{ mA}$, $C_{IN} = 68\text{ }\mu\text{F}$, $C_{OUT} = 33\text{ }\mu\text{F}$, $V_{EN} = V_{IN} - 0.3\text{ V}$

PARAMETER	SYMBOL	TEST CONDITION	MIN.	TYP.	MAX.	UNIT	
Output Voltage Tolerance	V_O	$10\text{ mA} < I_L < 1.5\text{ A}$ $V_{OUT}+1\text{ V} < V_{IN} < 6\text{ V}$	-2 -3	0	2 3	%	
Adjustable Pin Voltage (ADJ version)	V_{ADJ}	$10\text{ mA} < I_L < 1.5\text{ A}$ $V_{OUT}+1.5\text{ V} < V_{IN} < 6\text{ V}$	1.117 1.110	1.145	1.174 1.188	V	
Line Regulation ^(Note 3)	ΔV_{LINE}	$V_{OUT}+1\text{ V} < V_{IN} < 6\text{ V}$	-	0.25	0.55 0.60	%/V	
Load Regulation ^(Note 3, 4)	ΔV_{LOAD}	$10\text{ mA} < I_L < 1.5\text{ A}$	-	0.25	0.50 0.55	%	
Dropout Voltage ^(Note 5)	V_{DROP}	$I_L = 150\text{ mA}$	-	40	55 65	mV	
		$I_L = 1.5\text{ A}$	-	380	450 550		
Ground Pin Current ^(Note 6)	I_{GND1}	$I_L = 150\text{ mA}$	-	30	55 75	uA	
		$I_L = 1.5\text{ A}$	-	30	55 75		
Ground Pin Current ^(Note 7)	I_{GND2}	$V_{EN} < 0.2\text{ V}$	-	30	55 75	uA	
Output Peak Current	I_{PEAK}		2.0 1.7	2.2	-	A	
Thermal Shutdown Temperature	T_{SD}		-	165	-	$^\circ\text{C}$	
Thermal Shutdown Hysteresis	ΔT_{SD}		-	10	-	$^\circ\text{C}$	
Enable threshold	Logic Low	V_{IL}	Output = Low	-	0	0.2	V
	Logic High	V_{IH}	Output = High	$V_{IN}-0.3$	V_{IN}	-	V
Enable Input Current	I_{EN}	$V_{EN} = V_{IN}$	-	5	20	nA	

Note 1. Stresses listed as the absolute maximum ratings may cause permanent damage to the device. These are for stress ratings. Functional operating of the device at these or any other conditions beyond those indicated in the operational sections of the specifications is not implied. Exposure to absolute maximum rating conditions for extended periods may remain possibly to affect device reliability.

Note 2. The minimum operating value for input voltage is equal to either $(V_{OUT,NOM} + V_{DROP})$ or 2.5V, whichever is greater.

Note 3. Output voltage line regulation is defined as the change in output voltage from the nominal value due to change in the input line voltage. Output voltage load regulation is defined as the change in output voltage from the nominal value due to change in load current.

Note 4. Regulation is measured at constant junction temperature by using a 20ms current pulse. Devices are tested for load regulation in the load range from 10mA to 1.5A

Note 5. Dropout voltage is defined as the minimum input to output differential voltage at which the output drops 2% below the nominal value. Dropout voltage specification applies only to output voltages of 2.5V and above. For output voltages below 2.5V, the dropout voltage is nothing but the input to output differential, since the minimum input voltage is 2.5V

Note 6. Ground current, or quiescent current, is the difference between input and output currents. It's defined by $I_{GND1} = I_{IN} - I_{OUT}$ under the given loading condition. The total current drawn from the supply is the sum of the load current plus the ground pin current.

Note 7. Ground current, or standby current, is the input current drawn by a regulator when the output voltage is disabled by an enable signal.

TYPICAL OPERATING CHARACTERISTICS

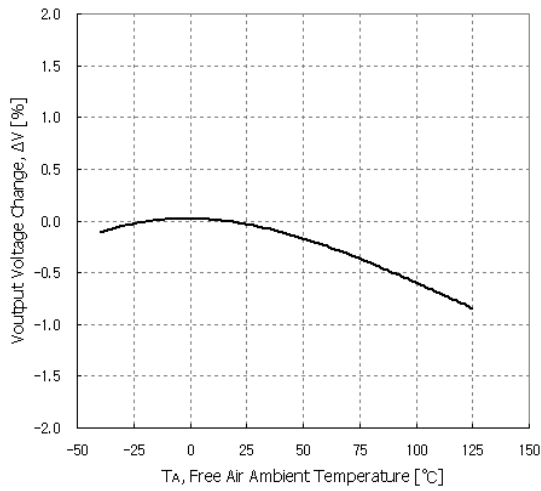

Ambient Temperature vs. Output Voltage Change

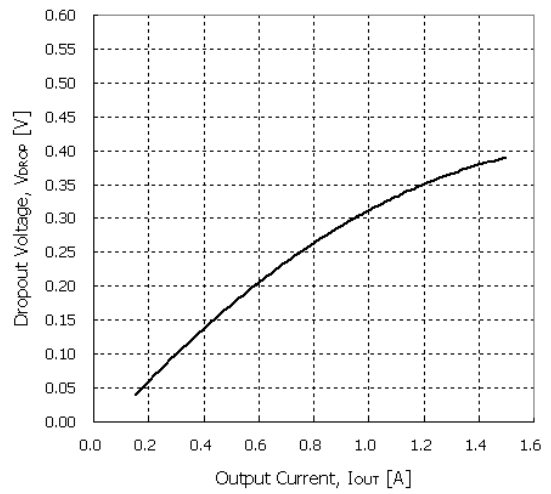

Output Current vs. Dropout Voltage

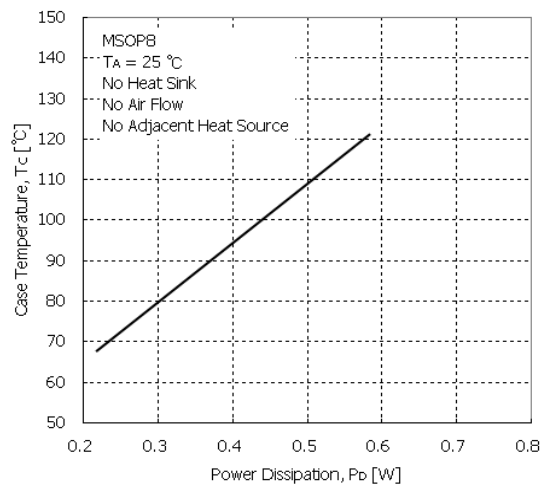

Power Dissipation vs. Case Temperature, MSOP8

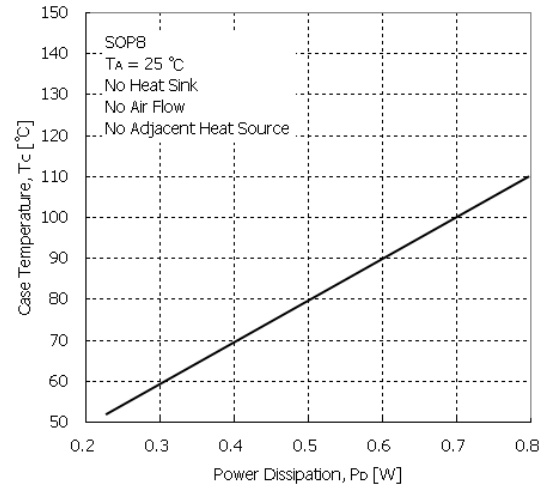

Power Dissipation vs. Case Temperature, SOP8

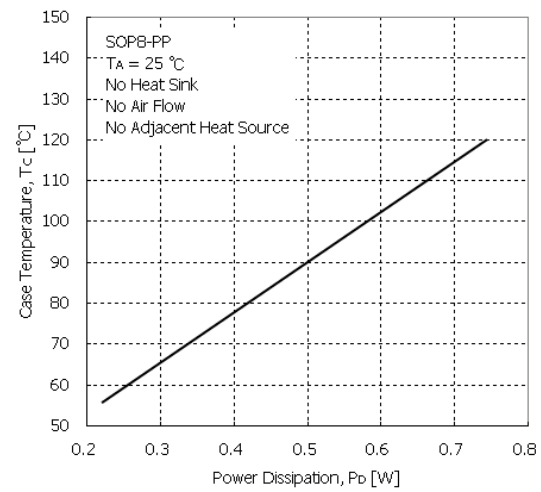

Power Dissipation vs. Case Temperature, SOP8-PP

T.B.D.

APPLICATION INFORMATION

Output Adjustment (Adjustable Version)

An adjustable output device has output voltage range of 1.145V to 5.0V. To obtain a desired output voltage, the following equation can be used with R1 resistor range of 10kΩ to 220kΩ

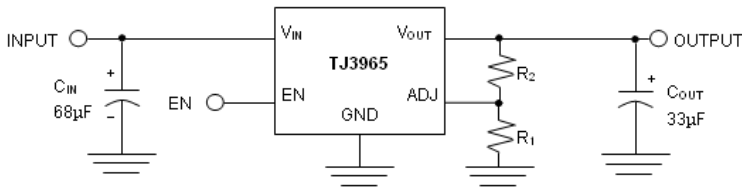

$$R2 = R1 \left(\frac{V_{OUT}}{1.145} - 1 \right)$$

To enhance output stability, a capacitor of 68pF to 100pF can be placed in series with V_{OUT} and ADJ.

SENSE Pin

In applications where the regulator output is not very close to the load, the TJ3965 can provide better remote load regulation characteristics using the SENSE pin. TJ3965 regulates the voltage at the output pin. Hence, the voltage at the remote load will be lower than the voltage at the output pin as a value of the voltage drop across the trace series resistance. If the sense option pin is not required, the sense pin must be connected to the V_{OUT} pin. Connecting the sense pin to the remote load will provide regulation at the remote load because the TJ3965 regulates the voltage at the sense pin when the sense option pin is used.

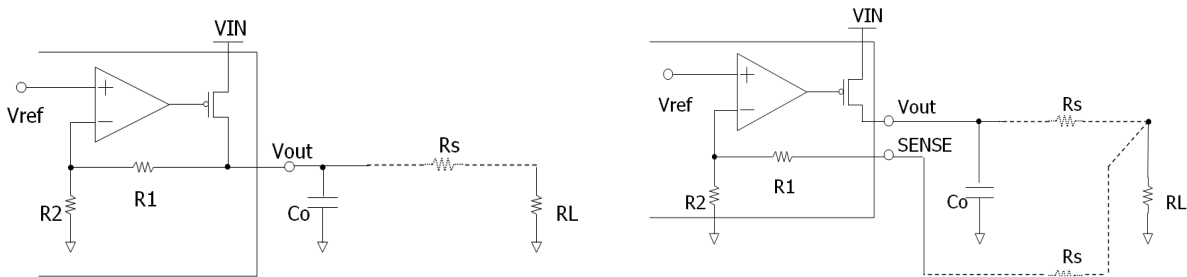

Maximum Output Current Capability

The TJ3965 can deliver a continuous current of 1.5A over the full operating junction temperature range. However, the output current is limited by the restriction of power dissipation which differs from packages. A heat sink may be required depending on the maximum power dissipation and maximum ambient temperature of application. With respect to the applied package, the maximum output current of 1.5A may be still undeliverable due to the restriction of the power dissipation of TJ3965. Under all possible conditions, the junction temperature must be within the range specified under operating conditions. The temperatures over the device are given by:

$$\begin{aligned} T_C &= T_A + P_D \times \theta_{CA} \\ T_J &= T_C + P_D \times \theta_{JC} \\ T_J &= T_A + P_D \times \theta_{JA} \end{aligned}$$

where T_J is the junction temperature, T_C is the case temperature, T_A is the ambient temperature, P_D is the total power dissipation of the device, θ_{CA} is the thermal resistance of case-to-ambient, θ_{JC} is the thermal

resistance of junction-to-case, and θ_{JA} is the thermal resistance of junction to ambient. The total power dissipation of the device is given by:

$$P_D = P_{IN} - P_{OUT} = (V_{IN} \times I_{IN}) - (V_{OUT} \times I_{OUT}) \\ = (V_{IN} \times (I_{OUT} + I_{GND})) - (V_{OUT} \times I_{OUT}) = (V_{IN} - V_{OUT}) \times I_{OUT} + V_{IN} \times I_{GND}$$

where I_{GND} is the operating ground current of the device which is specified at the Electrical Characteristics. The maximum allowable temperature rise (T_{Rmax}) depends on the maximum ambient temperature (T_{Amax}) of the application, and the maximum allowable junction temperature (T_{Jmax}):

$$T_{Rmax} = T_{Jmax} - T_{Amax}$$

The maximum allowable value for junction-to-ambient thermal resistance, θ_{JA} , can be calculated using the formula:

$$\theta_{JA} = T_{Rmax} / P_D$$

TJ3965 is available in SOT223, MSOP8, SOP8-PP, TO263, and TO220 packages. The thermal resistance depends on amount of copper area or heat sink, and on air flow. If the maximum allowable value of θ_{JA} calculated above is over 140 °C/W for SO-223 package, over 220 °C/W for MSOP8 package, over 165 °C/W for SOP8 package, over 170 °C/W for SOP8-PP package, over 80 °C/W for TO263 package, over 75 °C/W for TO220 package, no heat sink is needed since the package can dissipate enough heat to satisfy these requirements. If the value for allowable θ_{JA} falls near or below these limits, a heat sink or proper area of copper plane is required.

In summary, the absolute maximum ratings of thermal resistances are as follow:

Absolute Maximum Ratings of Thermal Resistance

No heat sink / No air flow / No adjacent heat source / $T_A = 25^\circ\text{C}$

Characteristic	Symbol	Max. Rating	Unit
Thermal Resistance Junction-To-Ambient / SOT223	$\theta_{JA-SOT223}$	140	°C/W
Thermal Resistance Junction-To-Ambient / MSOP8	$\theta_{JA-MSOP8}$	220	°C/W
Thermal Resistance Junction-To-Ambient / SOP8	$\theta_{JA-SOP8}$	165	°C/W
Thermal Resistance Junction-To-Ambient / SOP8-PP	$\theta_{JA-SOP8-PP}$	175	°C/W
Thermal Resistance Junction-To-Ambient / TO263	$\theta_{JA-TO263}$	80	°C/W
Thermal Resistance Junction-To-Ambient / TO220	$\theta_{JA-TO220}$	75	°C/W

T.B.D.