

Version:
September 20, 2017



(PWR)
**Pulse Withstanding
Chip Resistor**

Token Electronics Industry Co., Ltd.

Taiwan: No.137, Sec. 1, Zhongxing Rd., Wugu District,
New Taipei City, Taiwan, R.O.C. 24872
Tel: +886 2981 0109 **Fax:** +886 2988 7487

China: 12F, Zhong Xing Industry Bld., Chuang Ye Road,
Nan Shan District, Shen Zhen City,
Guang Dong, China 518054
Tel: +86 755 26055363; **Fax:** +86 755 26055365

Web: www.token.com.tw

mailto: rfq@token.com.tw



▶ Product Introduction

Token (PWR) pulse withstanding chip resistors provide 50 percent increase in power dissipation.

Features :

- High Power Rating
- Tolerance from $\pm 0.5\%$ ~ $\pm 5\%$
- Improved Working Voltage Ratings
- Standard Package sizes 0603 ~ 2512
- Excellent Pulse Withstanding Performance

Applications :

- Power Supplies, Diagnostic Equipment
- Industrial Controls, LCD Video Monitors
- Portable Battery Chargers, Medical Devices
- Motor Controls and Line-Powered Equipment
- Metering (Testing/Measurement), Circuit Protection Devices

As electronic design engineers have increased the power density of their equipment, the demand for smaller surface mount single-chip circuit protection resistors has also increased. Token developed the PWR Series resistors to provide an economical alternative to bulky molded wire-wound components or multi-chip solutions while saving both PC board space and manufacturing costs.

To meet the increased demand for the PWR Series resistors, Token has developed a series of pulse withstanding chip resistors with improved power ratings in reduced surface mounted sizes. Designated the PWR Series, the SMD resistors deliver up to 50 percent higher power ratings than conventional surface mount resistors - up to 1.5W in a standard 2512 size chip.

Token is able to boost this power rating up to 50 percent through a combination of proprietary power film materials and advanced manufacturing processes. The PWR Series Resistors are available in four standard sizes (0603, 0805, 1206, 1210, 2010 and 2512) with power ratings from 0.125W to 1.5W, and maximum operating voltage ratings for 100V to 500V. Resistance range is from 10 Ω to 20 M Ω , with tolerance tight to 0.5 percent. The PWR meets restriction of hazardous substances RoHS directive and RoHS compliance.

Along with the increased power ratings, the PWR Series resistors also feature high surge and high voltage ratings, making them extremely stable in demanding surge and pulse environments. The PWR Series chip resistors are specified for use in power supplies, circuit protection devices, portable battery chargers, motor controls and line-powered equipment.

Token will also produce devices outside these specifications to meet specific customer requirements, please contact our sales or link to Token official website " [Chip Resistors](http://www.token.com.tw) "for more information.



► Dimensions

Dimensions (Unit: mm) (PWR)

Codes	L (Unit: mm)	W (Unit: mm)	T (Unit: mm)	D1 (Unit: mm)	D2 (Unit: mm)	Weight (g)/1000pcs
PWR03 (0603)	1.60±0.10	0.80±0.10	0.45±0.10	0.30±0.20	0.30±0.20	2,042
PWR05 (0805)	2.00±0.10	1.25±0.10	0.50±0.10	0.35±0.20	0.40±0.25	4,368
PWR06 (1206)	3.10±0.10	1.55±0.10	0.55±0.10	0.50±0.25	0.50±0.20	8,947
PWR13 (1210)	3.10±0.10	2.60±0.15	0.55±0.10	0.50±0.25	0.50±0.20	15,959
PWR10 (2010)	5.00±0.10	2.50±0.15	0.55±0.10	0.60±0.25	0.50±0.20	24,241
PWR12 (2512)	6.35±0.10	3.10±0.15	0.55±0.10	0.60±0.25	0.50±0.20	39,448

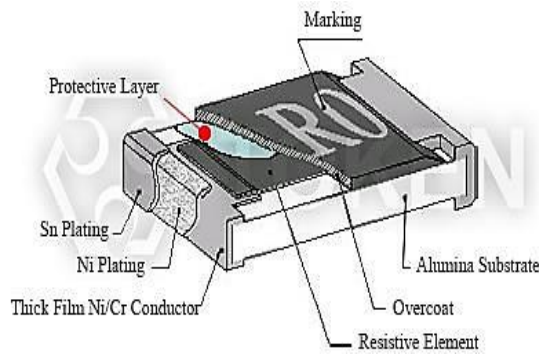

Pulse Withstanding Chips (PWR) Construction

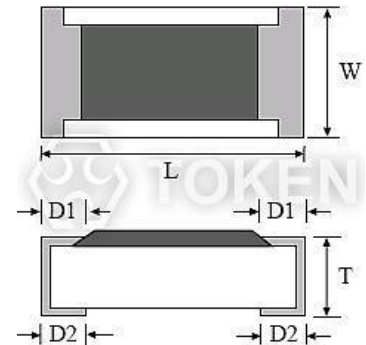

Dimensions (Unit: mm) (PWR)

Recommend Land Pattern (Unit: mm) (PWR)

Codes	A (mm)	B (mm)	C (mm)
PWR03 (0603)	0.90	0.60	0.90
PWR05 (0805)	1.20	0.70	1.30
PWR06 (1206)	2.00	0.90	1.60
PWR13 (1210)	2.00	0.90	2.80
PWR10 (2010)	3.80	0.90	2.80
PWR12 (2512)	3.80	1.60	3.50

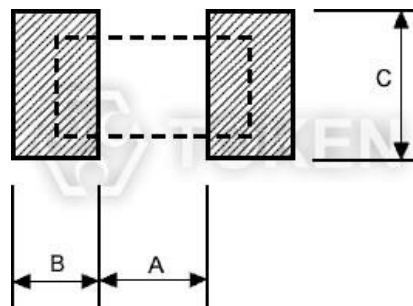

Recommend Land Pattern (PWR)

► Electrical Spec.

Standard Electrical Specifications (PWR)

Type	Power Rating at 70°C	Operating Temp. Range	Max Operating Voltage	Max Overloading Voltage	Resistance Tolerance (%)	Resistance Range (Ω)	TCR PPM/°C
PWR03 (0603)	1/10W	-55 ~ +155°C	50V	100V	±0.5%	10~294	±200
					±1%, ±5%	1~294	±200
					±0.5%, ±1%, ±5%	300~1M	±100
PWR05 (0805)	1/8W	-55 ~ +155°C	150V	300V	±0.5%	10~294	±200
					±1%, ±5%	1~294	±200
					±0.5%, ±1%, ±5%	300~20M	±100
PWR06 (1206)	1/3W	-55 ~ +155°C	200V	400V	±0.5%	10~20	±200
					±1%, ±5%	1~20	±200
					±0.5%, ±1%, ±5%	20.5~20M	±100
PWR13 (1210)	1/2W	-55 ~ +155°C	200V	400V	±0.5%	10~20	±200
					±1%, ±5%	1~20	±200
					±0.5%, ±1%, ±5%	20.5~20M	±100
PWR10 (2010)	3/4W	-55 ~ +155°C	400V	800V	±0.5%	10~20	±200
					±1%, ±5%	1~20	±200
					±0.5%, ±1%, ±5%	20.5~20M	±100
PWR12 (2512)	1.5W	-55 ~ +155°C	500V	1000V	±0.5%	10~20	±200
					±1%, ±5%	1~20	±200
					±0.5%, ±1%, ±5%	20.5~20M	±100

- Lower Resistance :(1~10)Ω.
- Operating Voltage = $\sqrt{P * R}$, or Max. Operating Voltage listed in above table whichever is lower.
- Overloading Voltage = $2.5 * \sqrt{P * R}$, or Max. Overloading Voltage listed in above table whichever is lower.
- Optional specifications can be required.

High Power Rating Electrical Specifications (PWR)

Type	Power Rating at 70°C	Operating Temp. Range	Max Operating Voltage	Max Overloading Voltage	Resistance Tolerance (%)	Resistance Range (Ω)	TCR PPM/°C
PWR03 (0603)	1/8W, 1/5W	-55 ~ +155°C	50V	100V	±0.5%	10~294	±200
					±1%, ±5%	1~294	±200
					±0.5%, ±1%, ±5%	300~1M	±100
PWR05 (0805)	1/4W	-55 ~ +155°C	150V	300V	±0.5%	10~294	±200
					±1%, ±5%	1~294	±200
					±0.5%, ±1%, ±5%	300~20M	±100
PWR06 (1206)	1/2W	-55 ~ +155°C	200V	400V	±0.5%	10~20	±200
					±1%, ±5%	1~20	±200
					±0.5%, ±1%, ±5%	20.5~20M	±100
PWR10 (2010)	1W	-55 ~ +155°C	400V	800V	±0.5%	10~20	±200
					±1%, ±5%	1~20	±200
					±0.5%, ±1%, ±5%	20.5~20M	±100

- Lower Resistance :(1~10)Ω.
- Operating Voltage = $\sqrt{P * R}$, or Max. Operating Voltage listed in above table whichever is lower.
- Overloading Voltage = $2.5 * \sqrt{P * R}$, or Max. Overloading Voltage listed in above table whichever is lower.
- Optional specifications can be required.

► Environmental Characteristics

Environmental Characteristics (PWR)

Test Item	Specification	Test Method
Short Time Overload	±0.5%	JIS-C-5201-1 4.13 IEC-60115-1 4.13 RCWV*2.5 or Max Overloading Voltage whichever is lower for 5 seconds
Leaching	Individual leaching area ≥5% Total leaching area ≥10%	JIS-C-5201-1 4.18 IEC-60068-2-58 8.2.1 -55°C~155°C, 5 cycles
Temperature Coefficient of Resistance	As Spec.	JIS-C-5201-1 4.8 IEC-60115-1 4.8 +25/-55/+25/+125/+25°C
Load Life (Endurance)	±(1%+0.05Ω)	JIS-C-5201-1 4.25 IEC-60115-1 4.25.1 RCWV, 70°C, 1.5 hours ON, 0.5 hours OFF, total 1000 hours
Humidity (Steady State) (Damp Heat with Load)	±(0.5%+0.05Ω)	JIS-C-5201-1 4.24 IEC-60115-1 4.24 40±2°C, 90~95%RH, RCWV 1.5 hours ON, 0.5 hours OFF, total 1000 hours
Resistance to Dry Heat	±0.5%	JIS-C-5202-7.2 96 hours @ +155°C without load
Low Temperature Operation	±0.5%	JIS-C-5202-7.1 1hour, -65°C followed by 45 minutes of RCWV
Dry Heat	±(0.5%+0.05Ω)	JIS-C-5201-1 4.23 IEC-60115-1 4.23.2 at +155°C for 1000 hrs. 2010, 2512 sizes: 2mm; Other sizes: 3mm
Bending Strength	±(1%+0.05Ω)	JIS-C-5201-1 4.33 IEC-60115-1 4.33 Bending once for 5 seconds. 2010, 2512 sizes: 2mm; Other sizes: 3mm
Resistance to Soldering Heat	±(0.5%+0.05Ω)	JIS-C-5201-1 4.18 IEC-60115-1 4.18 260±5°C, 10±1seconds
Solderability	95% min coverage	JIS-C-5201-1 4.17 IEC-60115-1 4.17 245°C±5°C for 3 seconds
Dielectric Withstand Voltage (Voltage Proof)	No breakdown or flashover	JIS-C-5201-1 4.7 IEC-60115-1 4.7 1.42 times Max. Operating Voltage for 1 minute
Insulation Resistance	>10GΩ	JIS-C-5201-1 4.6 IEC-60115-1 4.6 Max. Overload Voltage for 1 minute

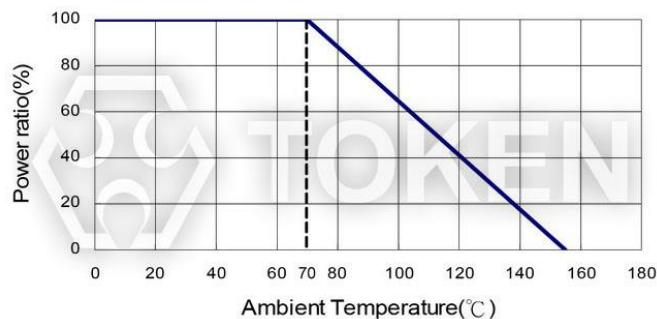

Power Derating Curve (PWR)

- Note: Storage Temperature: 25±3°C; Humidity: <80%RH
- Rated continuous Working Voltage (RCWV) = $\sqrt{\text{Power Rating} \times \text{Resistance Value } (\Omega)}$ or Max. Operating voltage whichever is lower.
- Storage Temperature: 15°C~28°C; Humidity < 80%RH;

▶ Lightning Surge

Lightning Surge of Pulse Withstanding Chip Resistor (PWR)

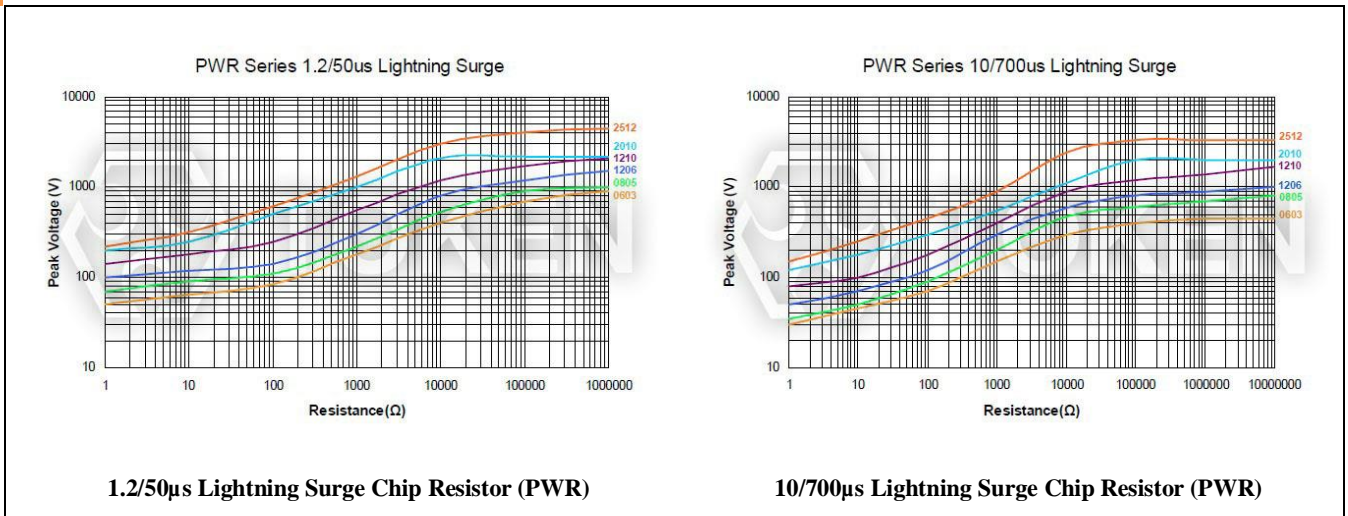

- Note: Lightning Surge of Pulse Withstanding Chip Resistors are tested in accordance with IEC 60 115-1 using both 10/700μs and 1.2/50μs pulse shapes.
- The limit of acceptance is a shift in resistance of less than 1% from the initial value.

Pulse withstanding capacity of Pulse Withstanding Chip Resistor (PWR)

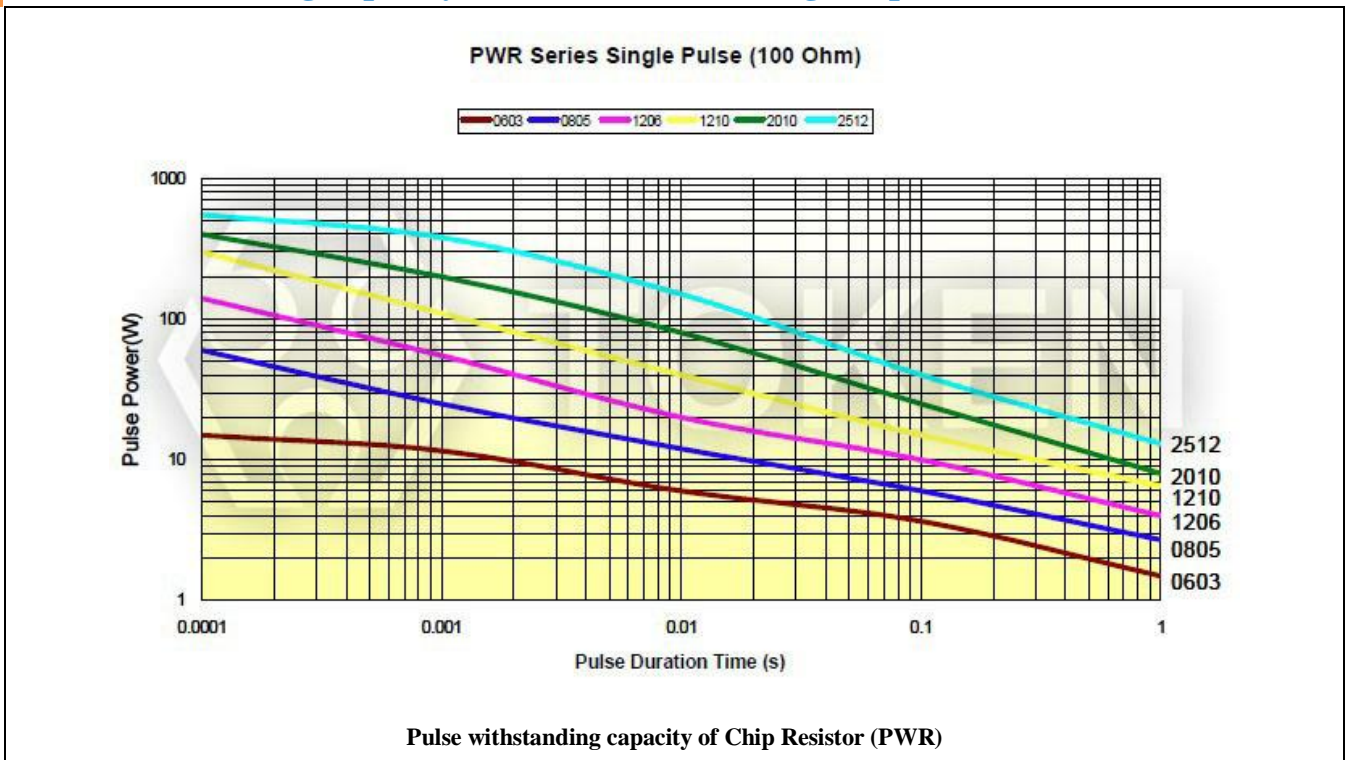

- Note: The single impulse graph is the result of 50 impulses of rectangular shape applied at one-minute intervals. The power applied was subject to the restrictions of the maximum permissible impulse voltage graph shown. The limit of acceptance was a shift in resistance of less than 1% from the initial value.

Continuous Pulse of Pulse Withstanding Chip Resistor (PWR)

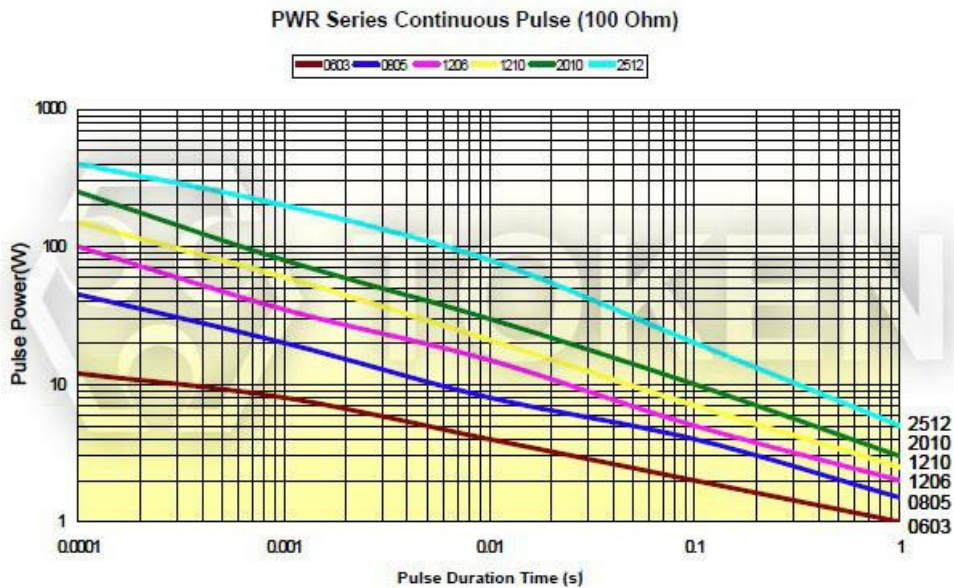

Continuous Pulse of Pulse Withstanding Chip Resistor (PWR)

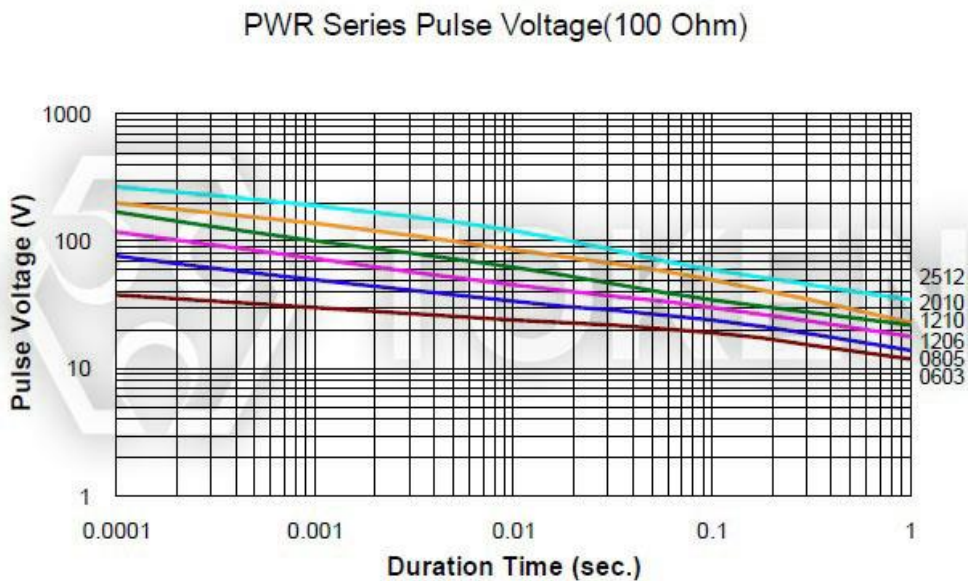

Pulse Voltage of Chip Resistor (PWR)

- Note: The continuous load graph was obtained by applying repetitive rectangular pulses where the pulse period was adjusted so that the average power dissipated in the resistor was equal to its rated power at 70°C. Again the limit of acceptance was a shift in resistance of less than 1% from the initial value.

► Packaging & Reel Tape

Packaging Quantity & Reel Specifications (Unit: mm) (PWR)

Codes	Packaging Quantity (KPCS)	Tape Width	Reel Diameter	ΦA (mm)	ΦB (mm)	ΦC (mm)	W (mm)	T (mm)	
PWR03 PWR05 PWR06 PWR13	Paper	5K	8mm	7 inch	178.5±1.5	60 ⁺¹	13.0±0.2	9.0±0.5	12.5±0.5
10K		8mm	10 inch	254±1	100±0.5	13.0±0.2	9.5±0.5	13.5±0.5	
20K		8mm	13 inch	330±1	100±0.5	13.0±0.2	9.5±0.5	13.5±0.5	
PWR10 PWR12	Embossed	4K	12mm	7 inch	178.5±1.5	60 ⁺¹	13.0±0.5	13.0±0.5	15.5±0.5
8K		12mm	10 inch	250±1	62±0.5	13.0±0.5	12.5±0.5	16.5±0.5	

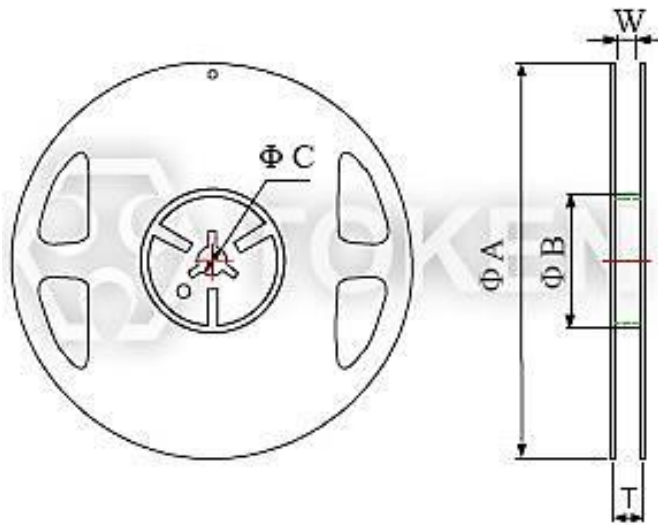

Packaging Quantity & Reel Specifications (PWR)

Paper Tape Specifications (Unit: mm) (PWR)

Codes	A (mm)	B (mm)	W (mm)	E (mm)	F (mm)	P ₀ (mm)	P ₁ (mm)	P ₂ (mm)	ΦD ₀ (mm)	T (mm)
PWR03	1.10±0.10	1.90±0.1	8.0±0.2	1.75±0.1	3.50±0.05	4.00±0.10	4.00±0.05	2.00±0.05	1.50 ^{+0.1,-0}	0.70±0.1
PWR05	1.60±0.10	2.40±0.2	8.0±0.2	1.75±0.1	3.50±0.05	4.00±0.10	4.00±0.05	2.00±0.05	1.50 ^{+0.1,-0}	0.85±0.1
PWR06	1.90±0.10	3.50±0.2	8.0±0.2	1.75±0.1	3.50±0.05	4.00±0.10	4.00±0.05	2.00±0.05	1.50 ^{+0.1,-0}	0.85±0.1
PWR13	2.90±0.10	3.50±0.2	8.0±0.2	1.75±0.1	3.50±0.05	4.00±0.10	4.00±0.05	2.00±0.05	1.50 ^{+0.1,-0}	0.85±0.1

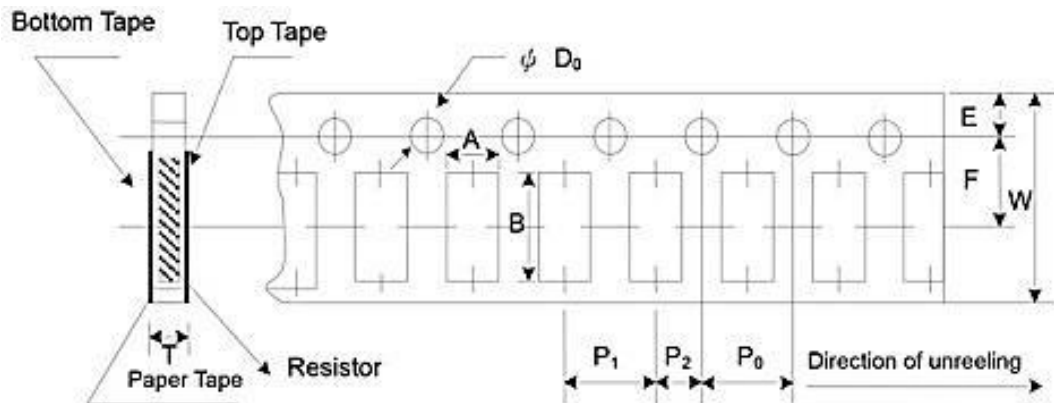

Paper Tape Specifications (PWR)

Emboss Plastic Tape Specifications (Unit: mm) (PWR)

Codes	A (mm)	B (mm)	W (mm)	E (mm)	F (mm)	P ₀ (mm)	P ₁ (mm)	P ₂ (mm)	ΦD ₀ (mm)	T (mm)
PWR10	2.8±0.10	5.5±0.10	12.0±0.3	1.75±0.1	5.5±0.05	4.00±0.10	4.00±0.1	2.00±0.05	1.50 ^{+0.1,-0}	1.2 ⁺⁰
PWR12	3.5±0.10	6.7±0.10	12.0±0.3	1.75±0.1	5.5±0.05	4.00±0.10	4.00±0.1	2.00±0.05	1.50 ^{+0.1,-0}	1.2 ⁺⁰

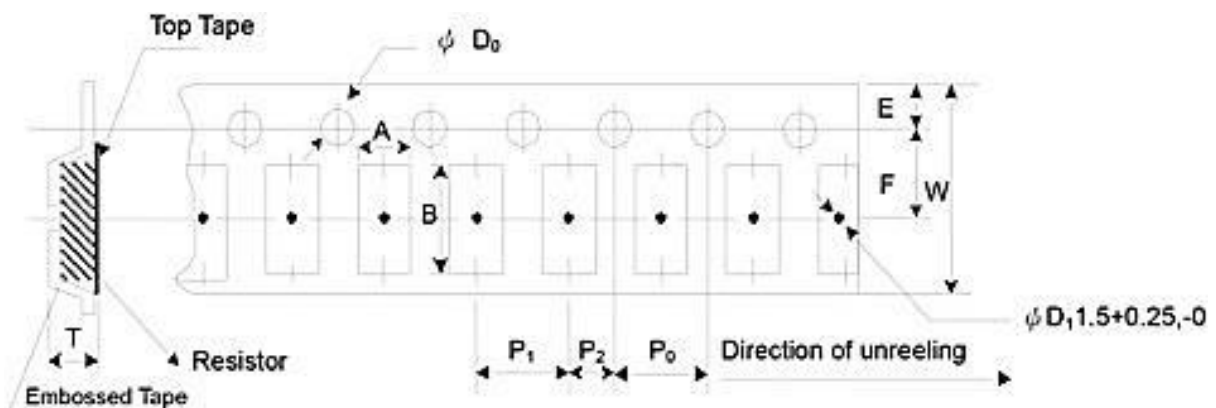

Embossed Plastic Tape (PWR)

▶ Application Notes

Pulse Withstanding Chip Resistors (PWR) Application & Soldering Notes

Today's electronic devices are becoming smaller and smaller. The requirement, in particular, for pulse withstand capability is growing due to the need to protect sensitive modern electronic systems. To meet this demand Token Electronics have designed a Pulse Withstanding Chip Resistor (PWR Series). The enhanced performance of the chips is made possible by the precise use of the best resistance inks and a closely controlled production process.

Application Notes:

- Applications vary from line protection for telecommunications to surge withstanding resistors for use in circuit breakers. Details of a typical telecomm and power supply application are given below.
- Telephone lines can be subjected to a large range of voltage disturbances, many of which can damage switching equipment. This has led to the need for circuit protection against both high voltage transients, usually of short duration caused by lightning strikes and overloads of longer duration, due to direct connection to mains power lines.
- These two faults are separated into primary and secondary protection.
 1. Primary protection handles the high voltage transients, and is usually located within the exchange.
 2. Secondary protection is usually built into the equipment to be protected, and deals with both current and voltage limiting.
- Voltage limiting prevents damage to the equipment and shock hazards, and current limiting prevents damage to wiring.
- To determine the suitability of a (PWR) series chip resistors for your application refer to the pulse withstanding data as given lighting surge performance using both 1.2/50 μ s and 10/700 μ s pulse shapes.

Soldering Notes:

- Electrical connection to a ceramic substrate or to a printed circuit board can be made by reflow or wave soldering of wrap-around terminations.
- Wrap-around terminations provide good leach properties and ensure reliable contact.
- Due to the robust construction, the (PWR) can be immersed in the solder bath for 30 seconds at 260 $^{\circ}$ C.
- This enables the resistor to be mounted on one side of a printed circuit board and wire-led components applied on the other side.
- (PWR) resistors themselves can operate at a maximum temperature of 155 $^{\circ}$ C.
- For soldered resistors, the joint temperature should not exceed 110 $^{\circ}$ C.
- This condition is met when the stated power levels at 70 $^{\circ}$ C and recommended pad and trace areas are used.
- Allowance should be made if smaller areas of copper are used.



Recommend Soldering Condition (PWR)

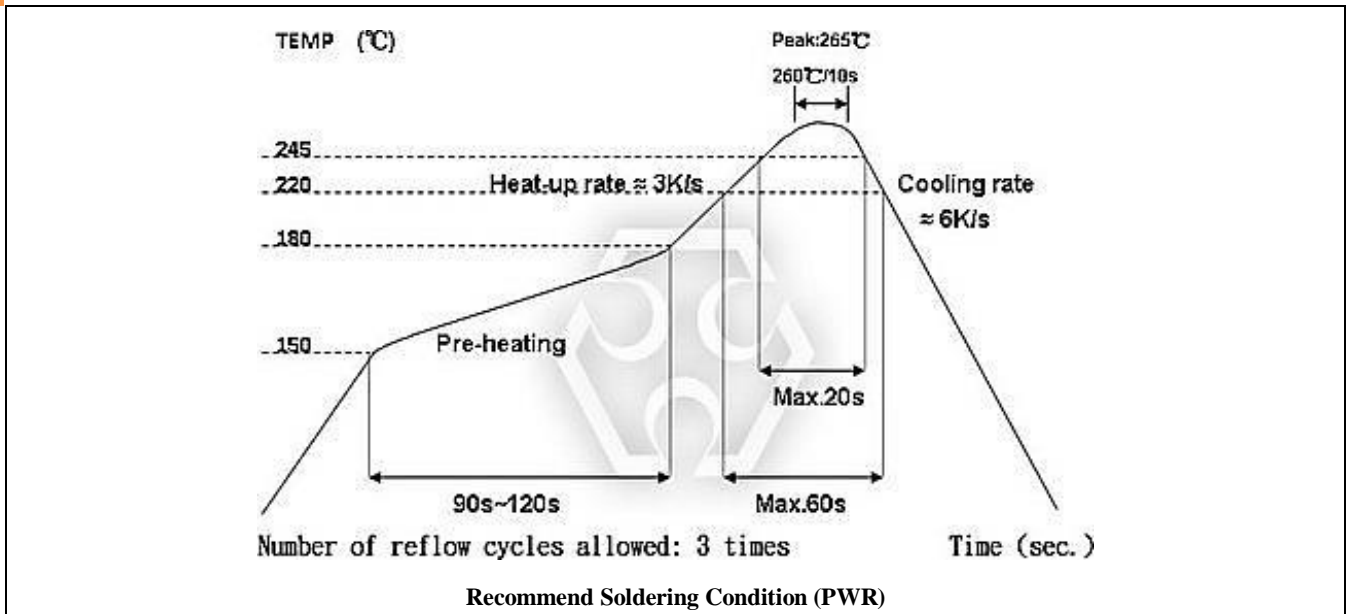

- Time of IR reflow soldering at maximum temperature point 260°C : 10s

Order Codes

Order Codes (PWR)

PWR	05	D	TR	C1	W	10R0						
Part Number	Dimensions		Package		TCR (ppm/°C)	Power Rating (W)		Resistance (Ω)		Marking		
	03	EIA0603	P	Bulk		C1	±100	A	1.5	10R0	10	Standard Marking for E96/E24
	05	EIA0805	TR	Taping Reel	C	±200	O	1/3	1000	100		
	06	EIA1206			D	±0.5%	Q	3/4	2201	2K2	N	
	13	EIA1210			F	±1%	T	1	1002	10K		
	10	EIA2010	J	±5%	U	1/2	1003	100K				
	12	EIA2512			V	1/4	1004	1M				
				P	1/5	1005	10M					
				W	1/8							
				X	1/10							

0805~2512 4 digits marking for Example Marking

Resistance	100Ω	2.2KΩ	10KΩ	49.9KΩ	100KΩ	1MΩ
Markin	1000	2201	1002	4992	1003	1004

0603: 3 digits Marking E24 Nominal Table

E24 code	10	11	12	13	15	16	18	20	22	24	27	30	33	36	39	43	47	51	56	62	68	75	82	91
----------	----	----	----	----	----	----	----	----	----	----	----	----	----	----	----	----	----	----	----	----	----	----	----	----

- Example: 101=100Ω 102=1KΩ (1st and 2nd are E24 code and 3rd code is multiplier)
- Resistance tolerance 1% for 0603: 3 digits marking in E96 (E96 series except E24 series)
- Digits marking for Example: 13C=13K3Ω; 68B=4K99Ω; 68X=49.9Ω

Marking Table E96 Nominal Table

code	02	03	04	06	07	08	09	10	11	13	14	15	16	17	19	20	21	22	23	24	25	26	27
E96	102	103	107	113	115	118	121	124	127	133	137	140	143	147	154	158	162	165	169	174	178	182	187
code	28	29	31	32	33	34	35	36	37	38	39	40	41	42	43	44	45	46	47	48	49	50	51
E96	191	196	205	210	215	221	226	232	237	243	249	255	261	267	274	280	287	294	301	309	316	324	332
code	52	53	54	55	56	57	58	59	60	61	62	63	64	65	66	67	68	69	70	71	72	73	74
E96	340	348	357	365	374	383	392	402	412	422	432	442	453	464	475	487	499	511	523	536	549	562	576
code	75	76	77	78	79	80	81	82	83	84	86	87	88	89	90	91	92	93	94	95	96		
E96	590	604	619	634	649	665	681	698	715	732	768	787	806	825	845	866	887	909	931	953	976		

Multiplier E96 Marking

Code	A	B	C	D	E	F	X	Y
Multiplier	10 ⁰	10 ¹	10 ²	10 ³	10 ⁴	10 ⁵	10 ⁻¹	10 ⁻²

► General Information

Token Thin Film Chips Add Powerful New Options

Token electronics provides the industry's most comprehensive range of precision thin film technologies for discrete, network, and integrated passive components used in instrumentation; automotive electronics; communications systems; and portable electronics applications. Ultra-reliable precision Nichrome resistive elements are available on ceramic or silicon substrates in a wide variety of surface mount resistors.

In response to market demands for increased precision and stability, Token has expanded range of nichrome thin-film chip resistors. Offering solutions to precision test and measurement and voltage regulation across industrial, military and medical monitoring equipment markets designed to offer superior humidity performance.

Token Thick Film Chips Cut the Cost of Precision Resistors

Token electronics has developed an extensive range of thick film / thin film resistive technologies for electronic circuits in power supplies; test and measurement; industrial electronics; telecommunications; audio circuits; automotive control systems; lighting controls; medical electronics; industrial equipment; and control systems applications.

In addition to this, proven thick film technologies from Token electronics provide a large range of standard resistive low Ohmic current sense products for critical battery management, and line termination. The enhanced performance of the chips is made possible by the precise use of the best resistance inks and a closely controlled production process.

Token Chip Low Ohmic Resistors come in Smaller Sizes and Minimized Power Consumption

Today's electronic devices are becoming smaller and smaller. As a result, designers are moving more towards surface mount components not only for new designs but also to design out large axial and other through-hole resistors.

In most cases this is a straight forward task as several resistor manufacturers offer chip resistors with performances to match axial parts. However in some cases, due to power rating or pulse withstanding requirements, this has been impossible. The requirement, in particular, for pulse withstand capability is growing due to the need to protect sensitive modern electronic systems. To meet this demand Token electronics have designed a Pulse Withstanding Chip Resistor (PWR Series).

