



UC3383

CMOS IC

PFM CONTROLLED, STEP-UP DC/DC CONVERTERS (VARIABLE DUTY RATIO)

DESCRIPTION

The UTC **UC3383** Series are PFM step-up DC/DC switching converter. The UTC **UC3383** can support both large and small currents. It automatically switches duty ratio (45%/75%) when it senses changes in load.

Both built-in and external transistor types include 5-pin and 3-pin packages, which are provided with either a CE (chip enable) function that reduces power consumption during shut-down mode, or a V_{DD} pin function (separated power and voltage detect pins).

FEATURES

- * Output Voltage Range: 2.0V~7.0V in 0.1V Increments
- * Operating (Start-up) Voltage Range: 0.9V~10V
- * Highly Accurate: Set-up Voltage $\pm 2.5\%$
- * Maximum Oscillator Frequency (Max Fosc1): 180kHz ($\pm 15\%$)
- * Variable Duty Ratio: 45%/75% ($\pm 5\%$)
- * Both Switching Transistor Built-in and External Types are Available
- * 5-Lead Package Offer Chip Enable or Independent V_{OUT} Pin Option.

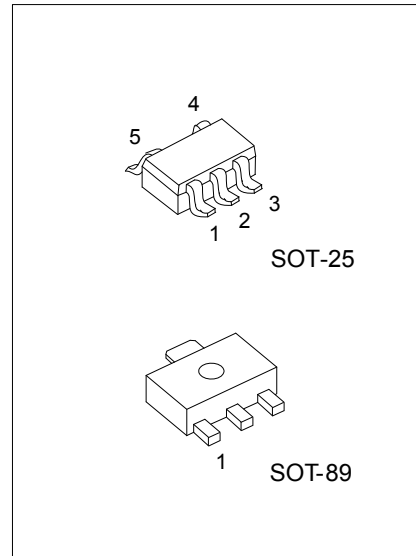

ORDERING INFORMATION

Ordering Number	Package	Pin Assignment					Packing
		1	2	3	4	5	
UC3383G-xx-AB3-R	SOT-89	V_{SS}	V_{OUT}	Lx	-	-	Tape Reel
UC3383G-xx-AF5-R	SOT-25	CE	V_{OUT}	NC	V_{SS}	Lx	Tape Reel

Note: Pin Assignment: NC: No Connection CE: Chip Enable
xx: Output Voltage, refer to Marking Information.

<p>UC3383G-xx-AB3-R</p> <ul style="list-style-type: none"> (1) Packing Type (2) Package Type (3) Output Voltage Code (4) Green Package 	<ul style="list-style-type: none"> (1) R: Tape Reel (2) AB3: SOT-89, AF5: SOT-25 (3) xx: refer to Marking Information (4) G: Halogen Free and Lead Free
--	---

MARKING INFORMATION

PACKAGE	VOLTAGE CODE	MARKING
SOT-25	20:2.0V	
	25:2.5V	
	26:2.6V	
	27:2.7V	
	28:2.8V	
	30:3.0V	
	31:3.1V	
	32:3.2V	
	33:3.3V	
	36:3.6V	
SOT-89	37:3.7V	
	40:4.0V	
	45:4.5V	
	50:5.0V	

PIN DESCRIPTION

PIN NO.		PIN NAME	FUNCTION
SOT-25	SOT-89		
1	-	CE	Chip Enable
2	2	V _{OUT}	Output voltage monitor, IC internal power supply
3	-	NC	No Connection
4	1	V _{SS}	Ground
5	3	Lx	Switch

BLOCK DIAGRAM

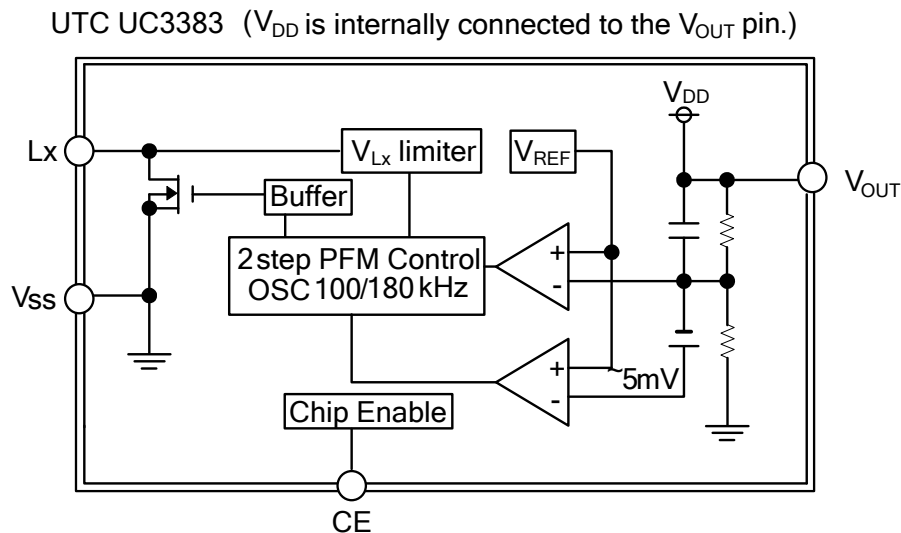

Note: The CE pin is only used with the 5-Lead Package.

■ ABSOLUTE MAXIMUM RATINGS (T_A=25°C, unless otherwise specified)

PARAMETER		SYMBOL	RATINGS	UNIT
V _{OUT} Input Voltage		V _{OUT}	12	V
Lx pin Voltage		V _{Lx}	12	V
CE Input Voltage		V _{CE}	12	V
V _{DD} Input Voltage		V _{DD}	12	V
Lx pin Current		I _{Lx}	400	mA
Power Dissipation	SOT-89	P _D	500	mW
	SOT-25		250	mW
Operating Junction Temperature		T _J	+125	°C
Ambient Operating Temperature		T _{OPR}	-30 ~ +80	°C
Storage Temperature		T _{STG}	-40 ~ +125	°C

Note Absolute maximum ratings are those values beyond which the device could be permanently damaged. Absolute maximum ratings are stress ratings only and functional device operation is not implied.

■ ELECTRICAL CHARACTERISTICS (T_A=25°C, V_{IN}=V_{OUT}× 0.6, unless otherwise specified)

UTC UC3383-2.0V (I_{OUT}=10mA)

PARAMETER	SYMBOL	TEST CONDITIONS	MIN	TYP	MAX	UNIT
Output Voltage	V _{OUT}	L, SD, C _L etc. connected	1.950	2.000	2.050	V
Maximum Input Voltage	V _{IN}				10	V
Oscillation Start-up Voltage	V _{ST}	I _{OUT} =1mA		0.80	0.90	V
Oscillation Hold Voltage	V _{HLD}	I _{OUT} =1mA	0.70			V
Lx Limit Voltage	V _{LxLMT}	Same as I _{DD1} . F _{OSC} >F _{OSC1} ×2	0.7		1.1	V
No-Load Input Current	I _{IN}	I _{OUT} =0mA (Note 1)		4.3	8.6	μA
Supply Current 1(Note 2)	I _{DD1}	V _{IN} =V _{OUT} ×0.95		13.6	27.3	μA
Supply Current 2	I _{DD2}	V _{IN} =V _{OUT} +0.5V		1.9	3.9	μA
Lx Leakage Current	I _{LxL}	No external components, V _{OUT} =V _{Lx} =10V.			1.0	μA
Lx Switch-On Resistance	R _{SWON}	Same as I _{DD1} . V _{Lx} =0.4V		9.1	13.7	Ω
Duty Ratio 1	DTY1	Same as I _{DD1} . Measuring of Lx waveform	70	75	80	%
Duty Ratio 2	DTY2	I _{OUT} =1mA. Measuring of Lx on-time	50	55	60	%
Efficiency	EFF1	L, SD, C _L etc. connected		70		%
Maximum Oscillation Frequency	F _{OSC1}	Same as I _{DD1} . 75% duty	100	120	130	kHz
	F _{OSC2}	Same as I _{DD1} . 45% duty	150	180	210	kHz

FOR 5-PINS PACKAGE ONLY

CE Voltage	High	V _{CEH}	Same as I _{DD1} . Existence of Lx Oscillation.	0.75		V
	Low	V _{CEL}	Same as I _{DD1} . Disappearance of Lx Oscillation		0.20	V
CE "High" Current	High	I _{CEH}	Same as I _{DD1} . V _{CE} =V _{OUT} ×0.95		0.25	μA
	Low	I _{CEL}	Same as I _{DD1} . V _{CE} =0V		-0.25	μA
Stand-by Current		I _{STB}	Same as I _{DD1} .		0.5	μA

■ ELECTRICAL CHARACTERISTICS(Cont.)

UTC UC3383-2.5V (I_{OUT}=10mA)

PARAMETER	SYMBOL	TEST CONDITIONS	MIN	TYP	MAX	UNIT
Output Voltage	V _{OUT}	L, SD, C _L etc. connected	2.438	2.500	2.563	V
Maximum Input Voltage	V _{IN}				10	V
Oscillation Start-up Voltage	V _{ST}	I _{OUT} =1mA		0.80	0.90	V
Oscillation Hold Voltage	V _{HLD}	I _{OUT} =1mA	0.70			V
Lx Limit Voltage	V _{LXLMT}	Same as I _{DD1} . F _{OSC} >F _{OSC} 1×2	0.7		1.1	V
No-Load Input Current	I _{IN}	I _{OUT} =0mA (Note 1)		4.45	8.95	μA
Supply Current 1(Note 2)	I _{DD1}	V _{IN} =V _{OUT} ×0.95		16.65	33.35	μA
Supply Current 2	I _{DD2}	V _{IN} =V _{OUT} +0.5V		2.0	4.05	μA
Lx Leakage Current	I _{LXL}	No external components, V _{OUT} =V _{Lx} =10V.			1.0	μA
Lx Switch-On Resistance	R _{SWON}	Same as I _{DD1} . V _{Lx} =0.4V		7.15	10.8	Ω
Duty Ratio 1	DTY1	Same as I _{DD1} . Measuring of Lx waveform	70	75	80	%
Duty Ratio 2	DTY2	I _{OUT} =1mA. Measuring of Lx on-time	40	45	50	%
Efficiency	EFFI	L, SD, C _L etc. connected		70		%
Maximum Oscillation Frequency	F _{OSC1}	Same as I _{DD1} . 75% duty	100	120	130	kHz
	F _{OSC2}	Same as I _{DD1} . 45% duty	150	180	210	kHz

FOR 5-PINS PACKAGE ONLY

CE Voltage	High	V _{CEH}	Same as I _{DD1} . Existence of Lx Oscillation.	0.75			V
	Low	V _{CEL}	Same as I _{DD1} . Disappearance of Lx Oscillation			0.20	V
CE "High" Current	High	I _{CEH}	Same as I _{DD1} . V _{CE} =V _{OUT} ×0.95			0.25	μA
	Low	I _{CEL}	Same as I _{DD1} . V _{CE} =0V			-0.25	μA
Stand-by Current		I _{STB}	Same as I _{DD1} .			0.5	μA

UTC UC3383-2.6V (I_{OUT}=10mA)

PARAMETER	SYMBOL	TEST CONDITIONS	MIN	TYP	MAX	UNIT
Output Voltage	V _{OUT}	L, SD, C _L etc. connected	2.535	2.600	2.665	V
Maximum Input Voltage	V _{IN}				10	V
Oscillation Start-up Voltage	V _{ST}	I _{OUT} =1mA		0.80	0.90	V
Oscillation Hold Voltage	V _{HLD}	I _{OUT} =1mA	0.70			V
Lx Limit Voltage	V _{LXLMT}	Same as I _{DD1} . F _{OSC} >F _{OSC} 1×2	0.7		1.1	V
No-Load Input Current	I _{IN}	I _{OUT} =0mA (Note 1)		4.48	9.02	μA
Supply Current 1(Note 2)	I _{DD1}	V _{IN} =V _{OUT} ×0.95		17.26	34.56	μA
Supply Current 2	I _{DD2}	V _{IN} =V _{OUT} +0.5V		2.02	4.08	μA
Lx Leakage Current	I _{LXL}	No external components, V _{OUT} =V _{Lx} =10V.			1.0	μA
Lx Switch-On Resistance	R _{SWON}	Same as I _{DD1} . V _{Lx} =0.4V		6.76	10.22	Ω
Duty Ratio 1	DTY1	Same as I _{DD1} . Measuring of Lx waveform	70	75	80	%
Duty Ratio 2	DTY2	I _{OUT} =1mA. Measuring of Lx on-time	40	45	50	%
Efficiency	EFFI	L, SD, C _L etc. connected		70		%
Maximum Oscillation Frequency	F _{OSC1}	Same as I _{DD1} . 75% duty	100	120	130	kHz
	F _{OSC2}	Same as I _{DD1} . 45% duty	150	180	210	kHz

FOR 5-PINS PACKAGE ONLY

CE Voltage	High	V _{CEH}	Same as I _{DD1} . Existence of Lx Oscillation.	0.75			V
	Low	V _{CEL}	Same as I _{DD1} . Disappearance of Lx Oscillation			0.20	V
CE "High" Current	High	I _{CEH}	Same as I _{DD1} . V _{CE} =V _{OUT} ×0.95			0.25	μA
	Low	I _{CEL}	Same as I _{DD1} . V _{CE} =0V			-0.25	μA
Stand-by Current		I _{STB}	Same as I _{DD1} .			0.5	μA

■ ELECTRICAL CHARACTERISTICS(Cont.)

UTC UC3383-2.7V (I_{OUT}=10mA)

PARAMETER	SYMBOL	TEST CONDITIONS	MIN	TYP	MAX	UNIT
Output Voltage	V _{OUT}	L, SD, C _L etc. connected	2.633	2.700	2.768	V
Maximum Input Voltage	V _{IN}				10	V
Oscillation Start-up Voltage	V _{ST}	I _{OUT} =1mA		0.80	0.90	V
Oscillation Hold Voltage	V _{HLD}	I _{OUT} =1mA	0.70			V
Lx Limit Voltage	V _{LXLMT}	Same as I _{DD1} . F _{OSC} >F _{OSC1} ×2	0.7		1.1	V
No-Load Input Current	I _{IN}	I _{OUT} =0mA (Note 1)		4.51	9.09	μA
Supply Current 1(Note 2)	I _{DD1}	V _{IN} =V _{OUT} ×0.95		17.87	35.77	μA
Supply Current 2	I _{DD2}	V _{IN} =V _{OUT} +0.5V		2.04	4.11	μA
Lx Leakage Current	I _{LXL}	No external components, V _{OUT} =V _{LX} =10V.			1.0	μA
Lx Switch-On Resistance	R _{SWON}	Same as I _{DD1} . V _{LX} =0.4V		6.37	9.64	Ω
Duty Ratio 1	DTY1	Same as I _{DD1} . Measuring of Lx waveform	70	75	80	%
Duty Ratio 2	DTY2	I _{OUT} =1mA. Measuring of Lx on-time	40	45	50	%
Efficiency	EFF1	L, SD, C _L etc. connected		70		%
Maximum Oscillation Frequency	Fosc1	Same as I _{DD1} . 75% duty	100	120	130	kHz
	Fosc2	Same as I _{DD1} . 45% duty	150	180	210	kHz

FOR 5-PINS PACKAGE ONLY

CE Voltage	High	V _{CEH}	Same as I _{DD1} . Existence of Lx Oscillation.	0.75			V
	Low	V _{CEL}	Same as I _{DD1} . Disappearance of Lx Oscillation			0.20	V
CE "High" Current	High	I _{CEH}	Same as I _{DD1} . V _{CE} =V _{OUT} ×0.95			0.25	μA
	Low	I _{CEL}	Same as I _{DD1} . V _{CE} =0V			-0.25	μA
Stand-by Current		I _{STB}	Same as I _{DD1} .			0.5	μA

UTC UC3383-2.8V (I_{OUT}=10mA)

PARAMETER	SYMBOL	TEST CONDITIONS	MIN	TYP	MAX	UNIT
Output Voltage	V _{OUT}	L, SD, C _L etc. connected	2.730	2.800	2.870	V
Maximum Input Voltage	V _{IN}				10	V
Oscillation Start-up Voltage	V _{ST}	I _{OUT} =1mA		0.80	0.90	V
Oscillation Hold Voltage	V _{HLD}	I _{OUT} =1mA	0.70			V
Lx Limit Voltage	V _{LXLMT}	Same as I _{DD1} . F _{OSC} >F _{OSC1} ×2	0.7		1.1	V
No-Load Input Current	I _{IN}	I _{OUT} =0mA (Note 1)		4.54	9.16	μA
Supply Current 1(Note 2)	I _{DD1}	V _{IN} =V _{OUT} ×0.95		18.48	36.98	μA
Supply Current 2	I _{DD2}	V _{IN} =V _{OUT} +0.5V		2.06	4.14	μA
Lx Leakage Current	I _{LXL}	No external components, V _{OUT} =V _{LX} =10V.			1.0	μA
Lx Switch-On Resistance	R _{SWON}	Same as I _{DD1} . V _{LX} =0.4V		5.98	9.06	Ω
Duty Ratio 1	DTY1	Same as I _{DD1} . Measuring of Lx waveform	70	75	80	%
Duty Ratio 2	DTY2	I _{OUT} =1mA. Measuring of Lx on-time	40	45	50	%
Efficiency	EFF1	L, SD, C _L etc. connected		70		%
Maximum Oscillation Frequency	Fosc1	Same as I _{DD1} . 75% duty	100	120	130	kHz
	Fosc2	Same as I _{DD1} . 45% duty	150	180	210	kHz

FOR 5-PINS PACKAGE ONLY

CE Voltage	High	V _{CEH}	Same as I _{DD1} . Existence of Lx Oscillation.	0.75			V
	Low	V _{CEL}	Same as I _{DD1} . Disappearance of Lx Oscillation			0.20	V
CE "High" Current	High	I _{CEH}	Same as I _{DD1} . V _{CE} =V _{OUT} ×0.95			0.25	μA
	Low	I _{CEL}	Same as I _{DD1} . V _{CE} =0V			-0.25	μA
Stand-by Current		I _{STB}	Same as I _{DD1} .			0.5	μA

■ ELECTRICAL CHARACTERISTICS(Cont.)

UTC UC3383-3.0V (I_{OUT}=30mA)

PARAMETER	SYMBOL	TEST CONDITIONS	MIN	TYP	MAX	UNIT
Output Voltage	V _{OUT}	L, SD, C _L etc. connected	2.925	3.000	3.075	V
Maximum Input Voltage	V _{IN}				10	V
Oscillation Start-up Voltage	V _{ST}	I _{OUT} =1mA		0.80	0.90	V
Oscillation Hold Voltage	V _{HLD}	I _{OUT} =1mA	0.70			V
Lx Limit Voltage	V _{LXLMT}	Same as I _{DD1} . F _{OSC} >F _{osc1} ×2	0.7		1.1	V
No-Load Input Current	I _{IN}	I _{OUT} =0mA (Note 1)		4.6	9.3	μA
Supply Current 1(Note 2)	I _{DD1}	V _{IN} =V _{OUT} ×0.95		19.7	39.4	μA
Supply Current 2	I _{DD2}	V _{IN} =V _{OUT} +0.5V		2.1	4.2	μA
Lx Leakage Current	I _{LXL}	No external components, V _{OUT} =V _{Lx} =10V.			1.0	μA
Lx Switch-On Resistance	R _{SWON}	Same as I _{DD1} . V _{Lx} =0.4V		5.2	7.9	Ω
Duty Ratio 1	DTY1	Same as I _{DD1} . Measuring of Lx waveform	70	75	80	%
Duty Ratio 2	DTY2	I _{OUT} =1mA. Measuring of Lx on-time	40	45	50	%
Efficiency	EFFI	L, SD, C _L etc. connected		80		%
Maximum Oscillation Frequency	Fosc1	Same as I _{DD1} . 75% duty	100	120	130	kHz
	Fosc2	Same as I _{DD1} . 45% duty	150	180	210	kHz

FOR 5-PINS PACKAGE ONLY

CE Voltage	High	V _{CEH}	Same as I _{DD1} . Existence of Lx Oscillation.	0.75			V
	Low	V _{CEL}	Same as I _{DD1} . Disappearance of Lx Oscillation			0.20	V
CE "High" Current	High	I _{CEH}	Same as I _{DD1} . V _{CE} =V _{OUT} ×0.95			0.25	μA
	Low	I _{CEL}	Same as I _{DD1} . V _{CE} =0V			-0.25	μA
Stand-by Current		I _{STB}	Same as I _{DD1} .			0.5	μA

UTC UC3383-3.1V (I_{OUT}=30mA)

PARAMETER	SYMBOL	TEST CONDITIONS	MIN	TYP	MAX	UNIT
Output Voltage	V _{OUT}	L, SD, C _L etc. connected	3.023	3.100	3.178	V
Maximum Input Voltage	V _{IN}				10	V
Oscillation Start-up Voltage	V _{ST}	I _{OUT} =1mA		0.80	0.90	V
Oscillation Hold Voltage	V _{HLD}	I _{OUT} =1mA	0.70			V
Lx Limit Voltage	V _{LXLMT}	Same as I _{DD1} . F _{OSC} >F _{osc1} ×2	0.7		1.1	V
No-Load Input Current	I _{IN}	I _{OUT} =0mA (Note 1)		4.635	9.365	μA
Supply Current 1(Note 2)	I _{DD1}	V _{IN} =V _{OUT} ×0.95		20.3	40.6	μA
Supply Current 2	I _{DD2}	V _{IN} =V _{OUT} +0.5V		2.115	4.23	μA
Lx Leakage Current	I _{LXL}	No external components, V _{OUT} =V _{Lx} =10V.			1.0	μA
Lx Switch-On Resistance	R _{SWON}	Same as I _{DD1} . V _{Lx} =0.4V		5.08	7.72	Ω
Duty Ratio 1	DTY1	Same as I _{DD1} . Measuring of Lx waveform	70	75	80	%
Duty Ratio 2	DTY2	I _{OUT} =1mA. Measuring of Lx on-time	40	45	50	%
Efficiency	EFFI	L, SD, C _L etc. connected		80		%
Maximum Oscillation Frequency	Fosc1	Same as I _{DD1} . 75% duty	100	120	130	kHz
	Fosc2	Same as I _{DD1} . 45% duty	150	180	210	kHz

FOR 5-PINS PACKAGE ONLY

CE Voltage	High	V _{CEH}	Same as I _{DD1} . Existence of Lx Oscillation.	0.75			V
	Low	V _{CEL}	Same as I _{DD1} . Disappearance of Lx Oscillation			0.20	V
CE "High" Current	High	I _{CEH}	Same as I _{DD1} . V _{CE} =V _{OUT} ×0.95			0.25	μA
	Low	I _{CEL}	Same as I _{DD1} . V _{CE} =0V			-0.25	μA
Stand-by Current		I _{STB}	Same as I _{DD1} .			0.5	μA

■ ELECTRICAL CHARACTERISTICS(Cont.)

UTC UC3383-3.2V (I_{OUT}=30mA)

PARAMETER	SYMBOL	TEST CONDITIONS	MIN	TYP	MAX	UNIT
Output Voltage	V _{OUT}	L, SD, C _L etc. connected	3.120	3.200	3.280	V
Maximum Input Voltage	V _{IN}				10	V
Oscillation Start-up Voltage	V _{ST}	I _{OUT} =1mA		0.80	0.90	V
Oscillation Hold Voltage	V _{HLD}	I _{OUT} =1mA	0.70			V
Lx Limit Voltage	V _{LXLMT}	Same as I _{DD1} . F _{OSC} >Fosc1×2	0.7		1.1	V
No-Load Input Current	I _{IN}	I _{OUT} =0mA (Note 1)		4.67	9.34	μA
Supply Current 1(Note 2)	I _{DD1}	V _{IN} =V _{OUT} ×0.95		20.9	41.8	μA
Supply Current 2	I _{DD2}	V _{IN} =V _{OUT} +0.5V		2.13	4.26	μA
Lx Leakage Current	I _{LXL}	No external components, V _{OUT} =V _{LX} =10V.			1.0	μA
Lx Switch-On Resistance	R _{SWON}	Same as I _{DD1} . V _{LX} =0.4V		4.96	7.54	Ω
Duty Ratio 1	DTY1	Same as I _{DD1} . Measuring of Lx waveform	70	75	80	%
Duty Ratio 2	DTY2	I _{OUT} =1mA. Measuring of Lx on-time	40	45	50	%
Efficiency	EFF1	L, SD, C _L etc. connected		80		%
Maximum Oscillation Frequency	Fosc1	Same as I _{DD1} . 75% duty	100	120	130	kHz
	Fosc2	Same as I _{DD1} . 45% duty	150	180	210	kHz
FOR 5-PINS PACKAGE ONLY						
CE Voltage	High	V _{CEH}	Same as I _{DD1} . Existence of Lx Oscillation.	0.75		V
	Low	V _{CEL}	Same as I _{DD1} . Disappearance of Lx Oscillation			0.20 V
CE "High" Current	High	I _{CEH}	Same as I _{DD1} . V _{CE} =V _{OUT} ×0.95			0.25 μA
	Low	I _{CEL}	Same as I _{DD1} . V _{CE} =0V			-0.25 μA
Stand-by Current	I _{STB}	Same as I _{DD1} .			0.5	μA

UTC UC3383-3.3V (I_{OUT}=30mA)

PARAMETER	SYMBOL	TEST CONDITIONS	MIN	TYP	MAX	UNIT
Output Voltage	V _{OUT}	L, SD, C _L etc. connected	3.218	3.300	3.383	V
Maximum Input Voltage	V _{IN}				10	V
Oscillation Start-up Voltage	V _{ST}	I _{OUT} =1mA		0.80	0.90	V
Oscillation Hold Voltage	V _{HLD}	I _{OUT} =1mA	0.70			V
Lx Limit Voltage	V _{LXLMT}	Same as I _{DD1} . F _{OSC} >Fosc1×2	0.7		1.1	V
No-Load Input Current	I _{IN}	I _{OUT} =0mA (Note 1)		4.705	9.41	μA
Supply Current 1(Note 2)	I _{DD1}	V _{IN} =V _{OUT} ×0.95		21.5	43	μA
Supply Current 2	I _{DD2}	V _{IN} =V _{OUT} +0.5V		2.145	4.29	μA
Lx Leakage Current	I _{LXL}	No external components, V _{OUT} =V _{LX} =10V.			1.0	μA
Lx Switch-On Resistance	R _{SWON}	Same as I _{DD1} . V _{LX} =0.4V		4.84	7.36	Ω
Duty Ratio 1	DTY1	Same as I _{DD1} . Measuring of Lx waveform	70	75	80	%
Duty Ratio 2	DTY2	I _{OUT} =1mA. Measuring of Lx on-time	40	45	50	%
Efficiency	EFF1	L, SD, C _L etc. connected		80		%
Maximum Oscillation Frequency	Fosc1	Same as I _{DD1} . 75% duty	100	120	130	kHz
	Fosc2	Same as I _{DD1} . 45% duty	150	180	210	kHz
FOR 5-PINS PACKAGE ONLY						
CE Voltage	High	V _{CEH}	Same as I _{DD1} . Existence of Lx Oscillation.	0.75		V
	Low	V _{CEL}	Same as I _{DD1} . Disappearance of Lx Oscillation			0.20 V
CE "High" Current	High	I _{CEH}	Same as I _{DD1} . V _{CE} =V _{OUT} ×0.95			0.25 μA
	Low	I _{CEL}	Same as I _{DD1} . V _{CE} =0V			-0.25 μA
Stand-by Current	I _{STB}	Same as I _{DD1} .			0.5	μA

■ ELECTRICAL CHARACTERISTICS(Cont.)

UTC UC3383-3.6V (I_{OUT}=30mA)

PARAMETER	SYMBOL	TEST CONDITIONS	MIN	TYP	MAX	UNIT
Output Voltage	V _{OUT}	L, SD, C _L etc. connected	3.510	3.600	3.690	V
Maximum Input Voltage	V _{IN}				10	V
Oscillation Start-up Voltage	V _{ST}	I _{OUT} =1mA		0.80	0.90	V
Oscillation Hold Voltage	V _{HLD}	I _{OUT} =1mA	0.70			V
Lx Limit Voltage	V _{LXLMT}	Same as I _{DD1} . F _{OSC} >F _{osc1} ×2	0.7		1.1	V
No-Load Input Current	I _{IN}	I _{OUT} =0mA (Note 1)		4.81	9.62	μA
Supply Current 1(Note 2)	I _{DD1}	V _{IN} =V _{OUT} ×0.95		23.3	46.6	μA
Supply Current 2	I _{DD2}	V _{IN} =V _{OUT} +0.5V		2.19	4.38	μA
Lx Leakage Current	I _{LXL}	No external components, V _{OUT} =V _{Lx} =10V.			1.0	μA
Lx Switch-On Resistance	R _{SWON}	Same as I _{DD1} . V _{Lx} =0.4V		4.48	6.82	Ω
Duty Ratio 1	DTY1	Same as I _{DD1} . Measuring of Lx waveform	70	75	80	%
Duty Ratio 2	DTY2	I _{OUT} =1mA. Measuring of Lx on-time	40	45	50	%
Efficiency	EFF1	L, SD, C _L etc. connected		80		%
Maximum Oscillation Frequency	Fosc1	Same as I _{DD1} . 75% duty	100	120	130	kHz
	Fosc2	Same as I _{DD1} . 45% duty	150	180	210	kHz

FOR 5-PINS PACKAGE ONLY

CE Voltage	High	V _{CEH}	Same as I _{DD1} . Existence of Lx Oscillation.	0.75			V
	Low	V _{CEL}	Same as I _{DD1} . Disappearance of Lx Oscillation			0.20	V
CE "High" Current	High	I _{CEH}	Same as I _{DD1} . V _{CE} =V _{OUT} ×0.95			0.25	μA
	Low	I _{CEL}	Same as I _{DD1} . V _{CE} =0V			-0.25	μA
Stand-by Current		I _{STB}	Same as I _{DD1} .			0.5	μA

UTC UC3383-3.7V (I_{OUT}=30mA)

PARAMETER	SYMBOL	TEST CONDITIONS	MIN	TYP	MAX	UNIT
Output Voltage	V _{OUT}	L, SD, C _L etc. connected	3.608	3.700	3.793	V
Maximum Input Voltage	V _{IN}				10	V
Oscillation Start-up Voltage	V _{ST}	I _{OUT} =1mA		0.80	0.90	V
Oscillation Hold Voltage	V _{HLD}	I _{OUT} =1mA	0.70			V
Lx Limit Voltage	V _{LXLMT}	Same as I _{DD1} . F _{OSC} >F _{osc1} ×2	0.7		1.1	V
No-Load Input Current	I _{IN}	I _{OUT} =0mA (Note 1)		4.845	9.755	μA
Supply Current 1(Note 2)	I _{DD1}	V _{IN} =V _{OUT} ×0.95		23.9	47.8	μA
Supply Current 2	I _{DD2}	V _{IN} =V _{OUT} +0.5V		2.205	4.41	μA
Lx Leakage Current	I _{LXL}	No external components, V _{OUT} =V _{Lx} =10V.			1.0	μA
Lx Switch-On Resistance	R _{SWON}	Same as I _{DD1} . V _{Lx} =0.4V		4.36	6.64	Ω
Duty Ratio 1	DTY1	Same as I _{DD1} . Measuring of Lx waveform	70	75	80	%
Duty Ratio 2	DTY2	I _{OUT} =1mA. Measuring of Lx on-time	40	45	50	%
Efficiency	EFF1	L, SD, C _L etc. connected		80		%
Maximum Oscillation Frequency	Fosc1	Same as I _{DD1} . 75% duty	100	120	130	kHz
	Fosc2	Same as I _{DD1} . 45% duty	150	180	210	kHz

FOR 5-PINS PACKAGE ONLY

CE Voltage	High	V _{CEH}	Same as I _{DD1} . Existence of Lx Oscillation.	0.75			V
	Low	V _{CEL}	Same as I _{DD1} . Disappearance of Lx Oscillation			0.20	V
CE "High" Current	High	I _{CEH}	Same as I _{DD1} . V _{CE} =V _{OUT} ×0.95			0.25	μA
	Low	I _{CEL}	Same as I _{DD1} . V _{CE} =0V			-0.25	μA
Stand-by Current		I _{STB}	Same as I _{DD1} .			0.5	μA

■ ELECTRICAL CHARACTERISTICS(Cont.)

UTC UC3383-4.0V (I_{OUT}=30mA)

PARAMETER	SYMBOL	TEST CONDITIONS	MIN	TYP	MAX	UNIT
Output Voltage	V _{OUT}	L, SD, C _L etc. connected	3.900	4.000	4.100	V
Maximum Input Voltage	V _{IN}				10	V
Oscillation Start-up Voltage	V _{ST}	I _{OUT} =1mA		0.80	0.90	V
Oscillation Hold Voltage	V _{HLD}	I _{OUT} =1mA	0.70			V
Lx Limit Voltage	V _{LXLMT}	Same as I _{DD1} . F _{OSC} >F _{osc1} ×2	0.7		1.1	V
No-Load Input Current	I _{IN}	I _{OUT} =0mA (Note 1)		4.95	9.94	μA
Supply Current 1(Note 2)	I _{DD1}	V _{IN} =V _{OUT} ×0.95		25.7	51.4	μA
Supply Current 2	I _{DD2}	V _{IN} =V _{OUT} +0.5V		2.25	4.5	μA
Lx Leakage Current	I _{LXL}	No external components, V _{OUT} =V _{Lx} =10V.			1.0	μA
Lx Switch-On Resistance	R _{SWON}	Same as I _{DD1} . V _{Lx} =0.4V		4.0	6.1	Ω
Duty Ratio 1	DTY1	Same as I _{DD1} . Measuring of Lx waveform	70	75	80	%
Duty Ratio 2	DTY2	I _{OUT} =1mA. Measuring of Lx on-time	40	45	50	%
Efficiency	EFF1	L, SD, C _L etc. connected		80		%
Maximum Oscillation Frequency	Fosc1	Same as I _{DD1} . 75% duty	100	120	130	kHz
	Fosc2	Same as I _{DD1} . 45% duty	150	180	210	

FOR 5-PINS PACKAGE ONLY

CE Voltage	High	V _{CEH}	Same as I _{DD1} . Existence of Lx Oscillation.	0.75			V
	Low	V _{CEL}	Same as I _{DD1} . Disappearance of Lx Oscillation			0.20	V
CE "High" Current	High	I _{CEH}	Same as I _{DD1} . V _{CE} =V _{OUT} ×0.95			0.25	μA
	Low	I _{CEL}	Same as I _{DD1} . V _{CE} =0V			-0.25	μA
Stand-by Current		I _{STB}	Same as I _{DD1} .			0.5	μA

UTC UC3383-4.5V (I_{OUT}=30mA)

PARAMETER	SYMBOL	TEST CONDITIONS	MIN	TYP	MAX	UNIT
Output Voltage	V _{OUT}	L, SD, C _L etc. connected	4.388	4.500	4.613	V
Maximum Input Voltage	V _{IN}				10	V
Oscillation Start-up Voltage	V _{ST}	I _{OUT} =1mA		0.80	0.90	V
Oscillation Hold Voltage	V _{HLD}	I _{OUT} =1mA	0.70			V
Lx Limit Voltage	V _{LXLMT}	Same as I _{DD1} . F _{OSC} >F _{osc1} ×2	0.7		1.1	V
No-Load Input Current	I _{IN}	I _{OUT} =0mA (Note 1)		5.125	10.25	μA
Supply Current 1(Note 2)	I _{DD1}	V _{IN} =V _{OUT} ×0.95		28.8	57.6	μA
Supply Current 2	I _{DD2}	V _{IN} =V _{OUT} +0.5V		2.325	4.65	μA
Lx Leakage Current	I _{LXL}	No external components, V _{OUT} =V _{Lx} =10V.			1.0	μA
Lx Switch-On Resistance	R _{SWON}	Same as I _{DD1} . V _{Lx} =0.4V		3.4	5.2	Ω
Duty Ratio 1	DTY1	Same as I _{DD1} . Measuring of Lx waveform	70	75	80	%
Duty Ratio 2	DTY2	I _{OUT} =1mA. Measuring of Lx on-time	40	45	50	%
Efficiency	EFF1	L, SD, C _L etc. connected		80		%
Maximum Oscillation Frequency	Fosc1	Same as I _{DD1} . 75% duty	100	120	130	kHz
	Fosc2	Same as I _{DD1} . 45% duty	150	180	210	

FOR 5-PINS PACKAGE ONLY

CE Voltage	High	V _{CEH}	Same as I _{DD1} . Existence of Lx Oscillation.	0.75			V
	Low	V _{CEL}	Same as I _{DD1} . Disappearance of Lx Oscillation			0.20	V
CE "High" Current	High	I _{CEH}	Same as I _{DD1} . V _{CE} =V _{OUT} ×0.95			0.25	μA
	Low	I _{CEL}	Same as I _{DD1} . V _{CE} =0V			-0.25	μA
Stand-by Current		I _{STB}	Same as I _{DD1} .			0.5	μA

■ ELECTRICAL CHARACTERISTICS(Cont.)

UTC UC3383-5.0V ($I_{OUT}=50mA$)

PARAMETER	SYMBOL	TEST CONDITIONS	MIN	TYP	MAX	UNIT
Output Voltage	V_{OUT}	L, SD, C_L etc. connected	4.875	5.000	5.125	V
Maximum Input Voltage	V_{IN}				10	V
Oscillation Start-up Voltage	V_{ST}	$I_{OUT}=1mA$		0.80	0.90	V
Oscillation Hold Voltage	V_{HLD}	$I_{OUT}=1mA$	0.70			V
Lx Limit Voltage	V_{LXLMT}	Same as I_{DD1} . $F_{OSC}>F_{osc1}\times 2$	0.7		1.1	V
No-Load Input Current	I_{IN}	$I_{OUT}=0mA$ (Note 1)		5.3	10.6	μA
Supply Current 1(Note 2)	I_{DD1}	$V_{IN}=V_{OUT}\times 0.95$		31.7	63.4	μA
Supply Current 2	I_{DD2}	$V_{IN}=V_{OUT}+0.5V$		2.4	4.8	μA
Lx Leakage Current	I_{LXL}	No external components, $V_{OUT}=V_{LX}=10V$.			1.0	μA
Lx Switch-On Resistance	R_{SWON}	Same as I_{DD1} . $V_{LX}=0.4V$		2.8	4.3	Ω
Duty Ratio 1	DTY1	Same as I_{DD1} . Measuring of Lx waveform	70	75	80	%
Duty Ratio 2	DTY2	$I_{OUT}=1mA$. Measuring of Lx on-time	40	45	50	%
Efficiency	EFF1	L, SD, C_L etc. connected		85		%
Maximum Oscillation Frequency	Fosc1	Same as I_{DD1} . 75% duty	100	120	130	kHz
	Fosc2	Same as I_{DD1} . 45% duty	150	180	210	kHz
FOR 5-PINS PACKAGE ONLY						
CE Voltage	High	V_{CEH}	Same as I_{DD1} . Existence of Lx Oscillation.	0.75		V
	Low	V_{CEL}	Same as I_{DD1} . Disappearance of Lx Oscillation		0.20	V
CE "High" Current	High	I_{CEH}	Same as I_{DD1} . $V_{CE}=V_{OUT}\times 0.95$		0.25	μA
	Low	I_{CEL}	Same as I_{DD1} . $V_{CE}=0V$		-0.25	μA
Stand-by Current		I_{STB}	Same as I_{DD1} .		0.5	μA

Note: 1. The Schottky diode (SD) must be type MA735, with reverse current(I_R) $<1.0\mu A$ at reverse voltage (V_R) =10V.

2. "Supply Current 1" is the supply current while the oscillator is continuously oscillating. The current actually provided by an external V_{IN} source is represented by "No-Load Input Current (I_{IN})".

■ TYPICAL APPLICATION CIRCUITS

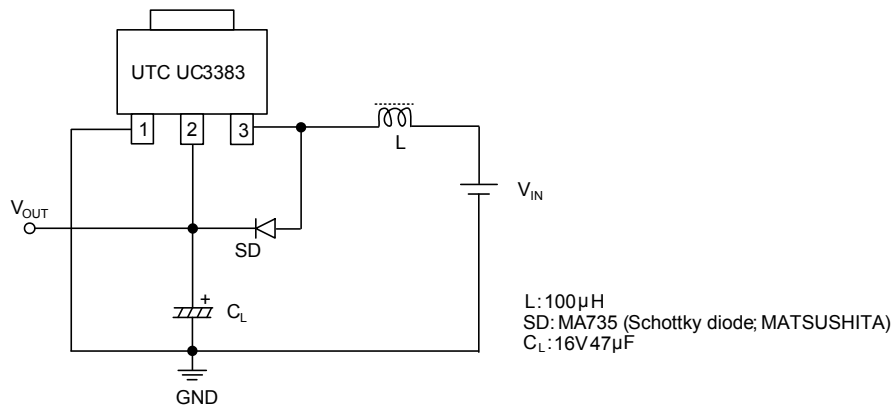

Fig.1 3-Lead Package Application(SOT-89)

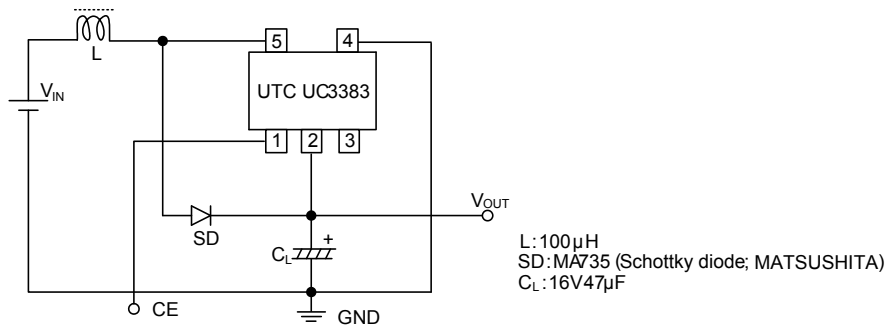
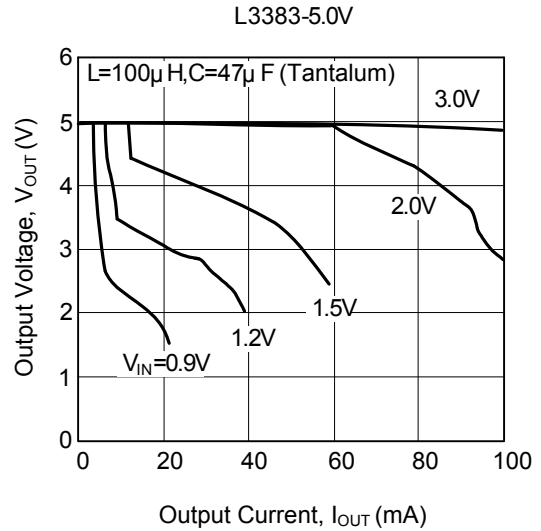
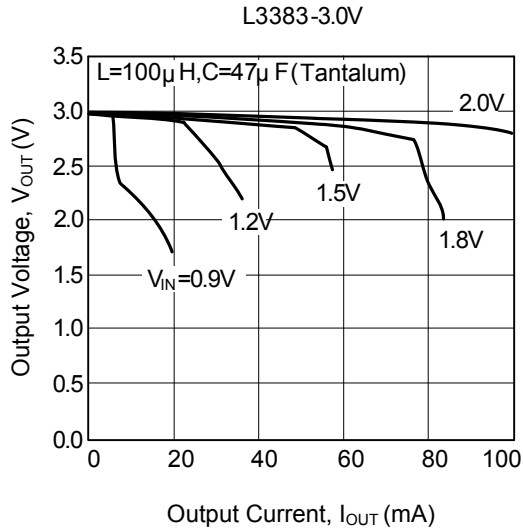

Fig.2 5-Lead Package Application(SOT-25)

■ TYPICAL CHARACTERISTICS (BUILT-IN SWITCHING TRANSISTOR)

(1) OUTPUT VOLTAGE vs. OUTPUT CURRENT



(2) EFFICIENCY vs. OUTPUT CURRENT

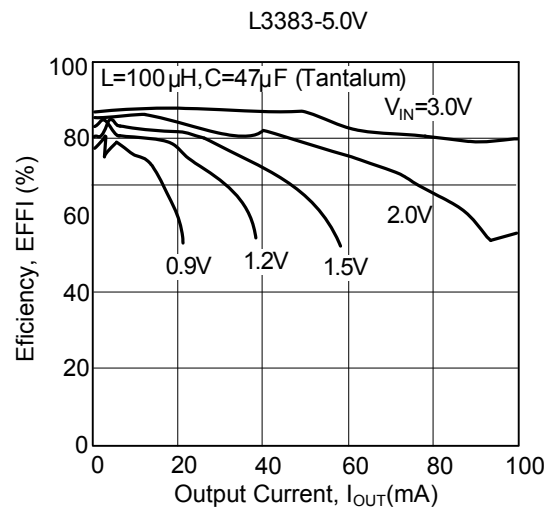
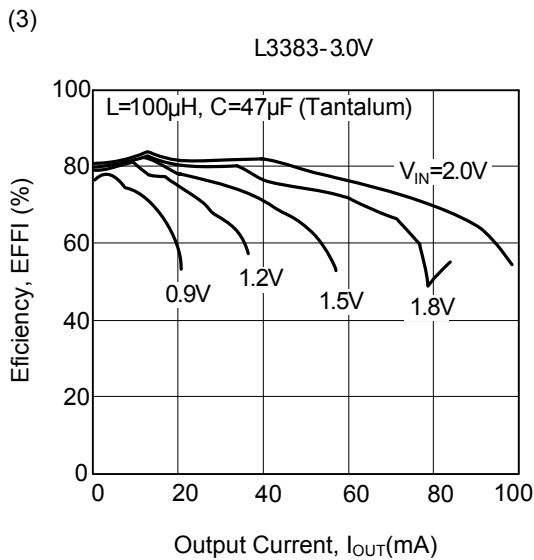

(3) RIPPLE VOLTAGE vs. OUTPUT CURRENT

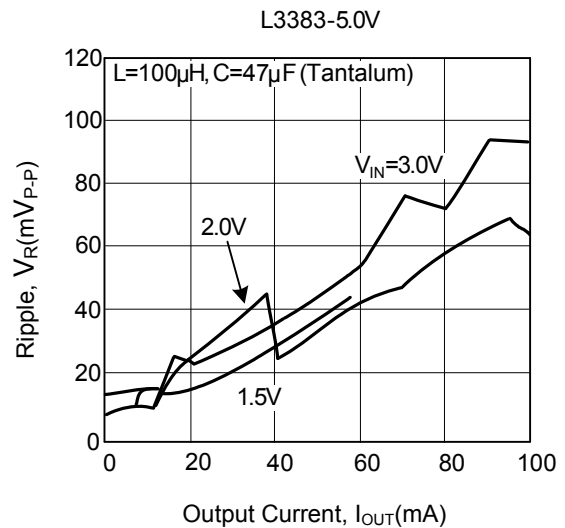
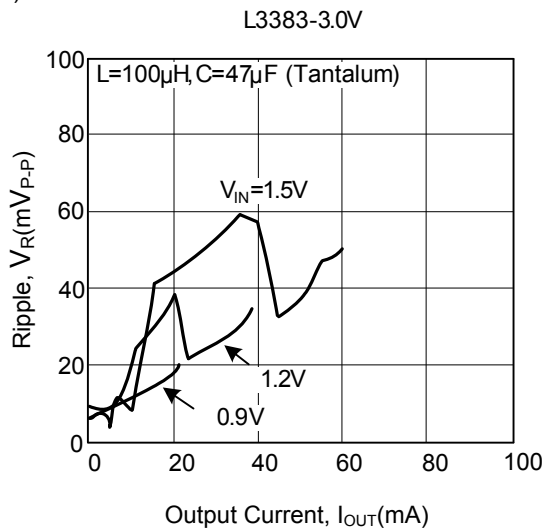

■ TYPICAL CHARACTERISTICS FOR UC3383-5.0

(1) Operating Start Voltage, Retain Voltage vs. Output Current

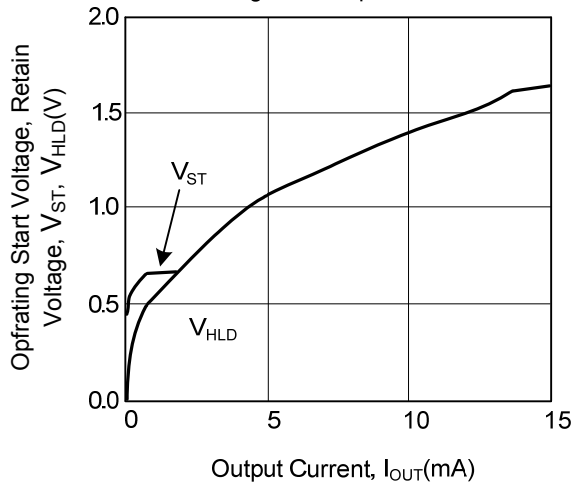

(2) Output Voltage vs. Temperature

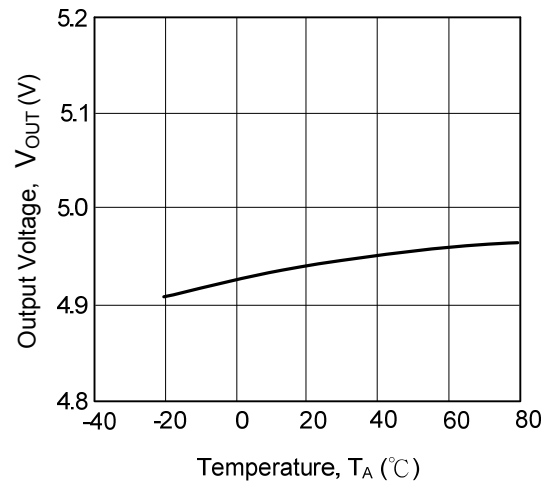

(3) Operating Start Voltage, Retain Voltage vs. Output Current

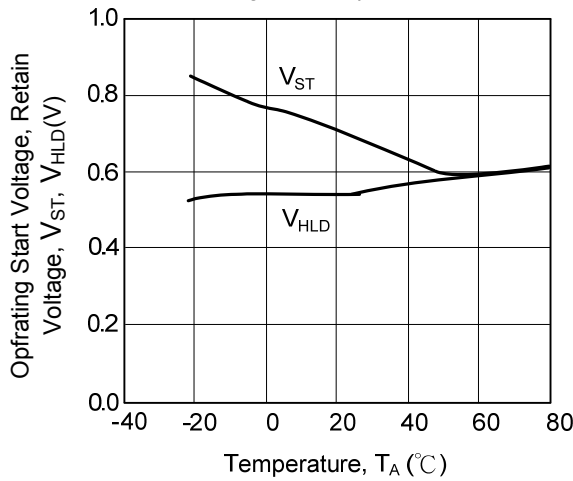

(4) Current Consumption 1 vs. Temperature

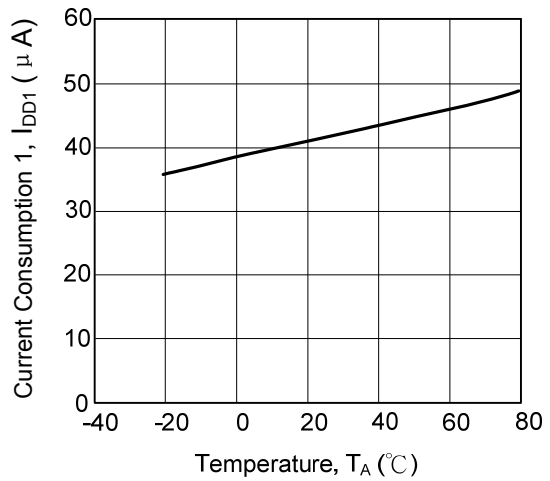

(5) Current Consumption 2 vs. Temperature

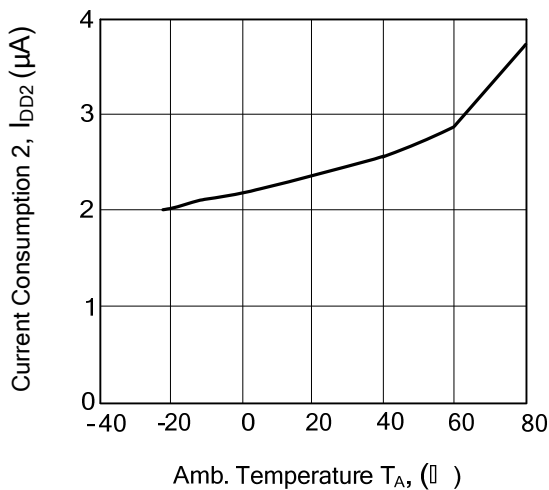

(6) Lx Switching-on Resistance vs. Temperature

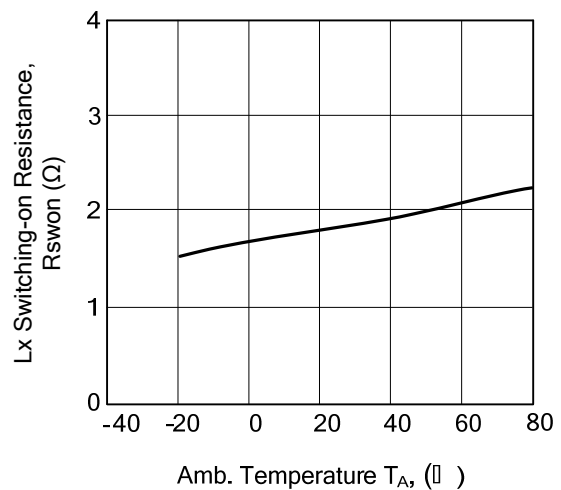

■ TYPICAL CHARACTERISTICS FOR UC3383-5.0V(cont.)

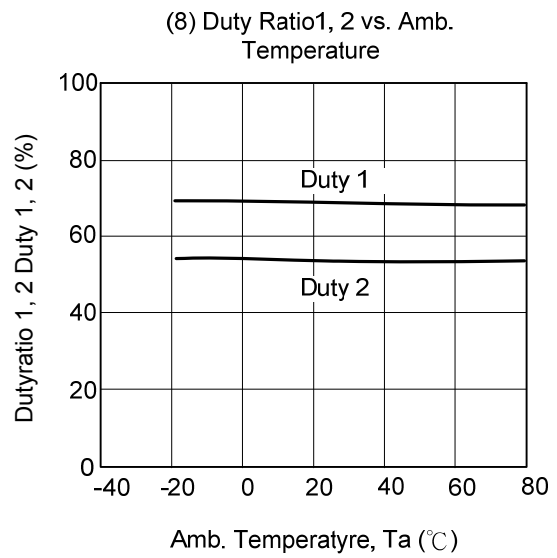
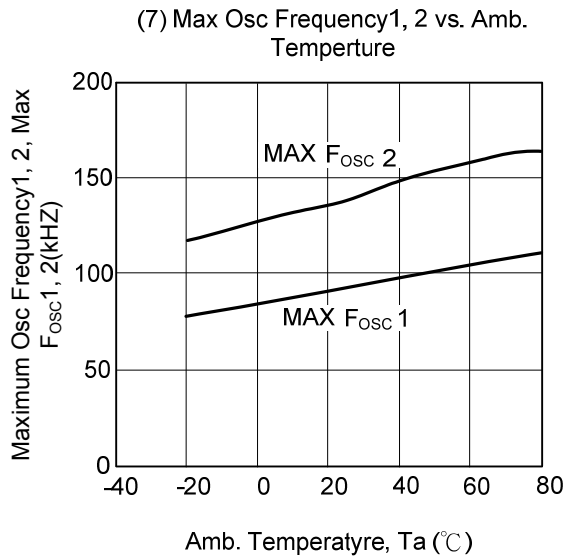

UTC assumes no responsibility for equipment failures that result from using products at values that exceed, even momentarily, rated values (such as maximum ratings, operating condition ranges, or other parameters) listed in products specifications of any and all UTC products described or contained herein. UTC products are not designed for use in life support appliances, devices or systems where malfunction of these products can be reasonably expected to result in personal injury. Reproduction in whole or in part is prohibited without the prior written consent of the copyright owner. The information presented in this document does not form part of any quotation or contract, is believed to be accurate and reliable and may be changed without notice.