

PLEASE CHECK WWW.MOLEX.COM FOR LATEST PART INFORMATION

Part Number: [0008580122](#)
Status: **Active**
Overview: [kk](#)
Description: 3.96mm (.156") Pitch KK® Crimp Terminal 2478, 18-24 AWG, Bag, Phosphor Bronze, 0.51µm (20µ") Selective Gold (Au)

Documents:

[Drawing \(PDF\)](#) [RoHS Certificate of Compliance \(PDF\)](#)
[Product Specification PS-08-50 \(PDF\)](#)

General

Product Family Crimp Terminals
 Series [2478](#)
 Crimp Quality Equipment Yes
 Overview [kk](#)
 Product Name KK®

Physical

Gender Female
 Material - Metal Phosphor Bronze
 Material - Plating Mating Gold
 Material - Plating Termination Gold
 Packaging Type Bag
 Plating min: Mating (µin) 15
 Plating min: Mating (µm) 0.375
 Plating min: Termination (µin) 2
 Plating min: Termination (µm) 0.05
 Termination Interface: Style Crimp or Compression
 Wire Insulation Diameter 2.79mm (.110") max.
 Wire Size AWG 18, 20, 22, 24
 Wire Size mm² N/A

Material Info

Old Part Number 2478-3-(550)L

Reference - Drawing Numbers

Packaging Specification PK-2759-001
 Product Specification PS-08-50
 Sales Drawing SD-2478

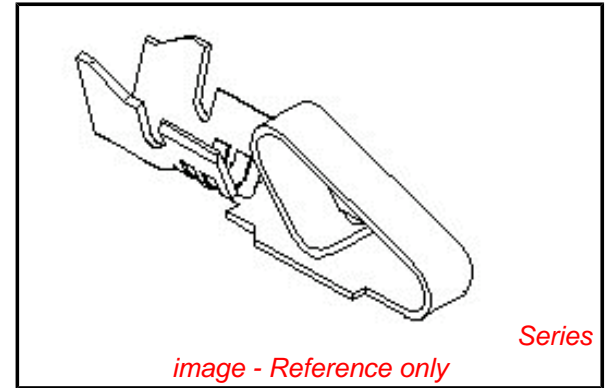

image - Reference only

EU RoHS

ELV and RoHS Compliant
REACH SVHC
Contains SVHC: No
Halogen-Free Status

China RoHS



Halogen-Free

Need more information on product environmental compliance?

Email productcompliance@molex.com
 For a multiple part number RoHS Certificate of Compliance, [click here](#)

Please visit the [Contact Us](#) section for any non-product compliance questions.

Search Parts in this Series

[2478Series](#)

Use With

[2574](#) , [2139](#) , [41695](#) , [3069](#) , [6422](#) , [5265](#) , [5239](#)

Application Tooling | FAQ

Tooling specifications and manuals are found by selecting the products below. Crimp Height Specifications are then contained in the Application Tooling Specification document.

Global

| Description | Product # |
|-----------------|----------------------------|
| Hand Crimper | 0638117500 |
| Extraction Tool | 0011030016 |

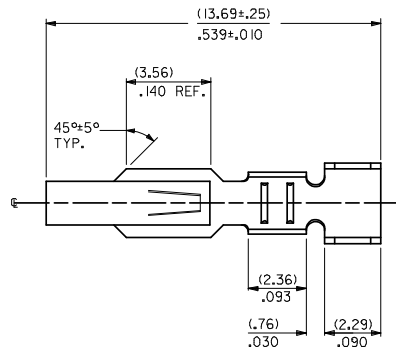
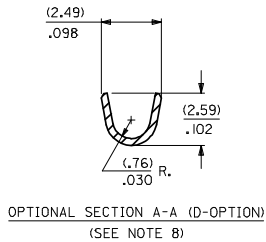
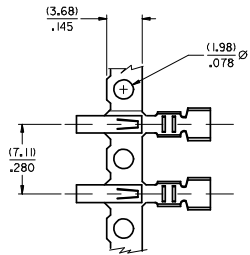

2478- * - * - *

MATERIAL CODE
(.27)/.0106 THK
1=BRASS
3=PHOS BRONZE

WINDING SPEC.
A=PER ES-339-A
BLANK=PER ES-339-B
L=LOOSE

OPTION CODE
BLANK=AS SHOWN
C=CAT EAR OPTION
D=OPTIONAL CONDUCTOR CRIMP (FOR IRELAND) (SEE OPT. SECTION A-A) WITHOUT CAT EARS
E=LOW INSERTION FORCE OPTION

FINISH: PER SDES-88
(P909) *OVERALL HOT TIN DIP: 2.54 MICROMETERS MIN.
(550) SELECT GOLD: 0.38 MICROMETERS MIN, OVERALL GOLD FLASH: 0.05 MICROMETERS MIN, OVERALL NICKEL UNDERPLATE: 0.76 MICROMETERS MIN.
(555) SELECT GOLD: 0.38 MICROMETERS MIN, OVERALL NICKEL UNDERPLATE: 0.76 MICROMETERS MIN.

*THE PRIMARY SHIPPING CARTON WILL BE LABELED "COMPLIANT TO RoHS DIRECTIVE 2002/95/EC AND ELV ANNEX II OF DIRECTIVE 2000/53/EC". CARTONS WITHOUT THIS LABEL MAY CONTAIN PRODUCT WITH TIN/LEAD PLATING.

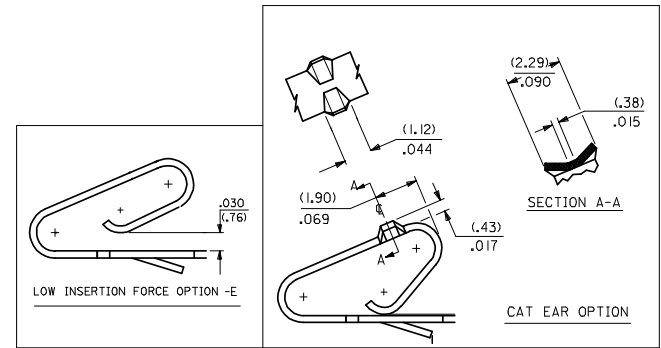
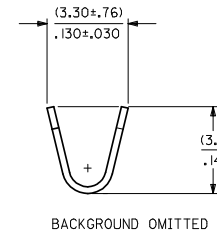
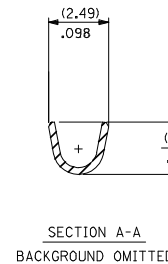
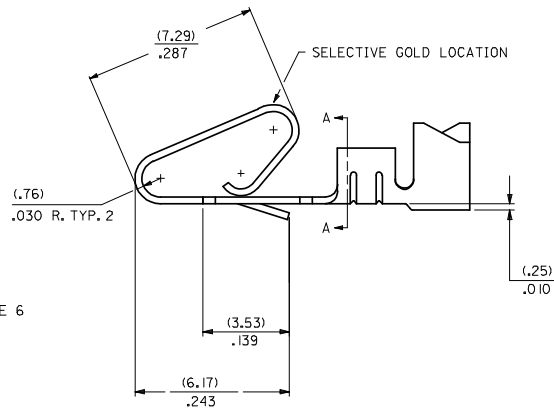
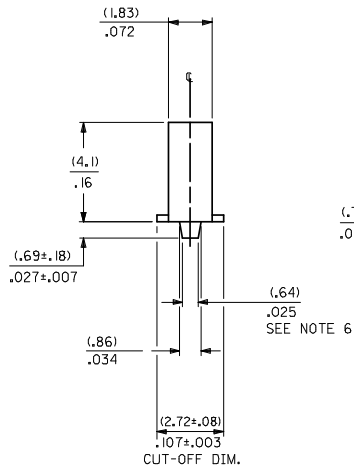

- NOTES:
- CRIMP ACCEPTS 18 TO 24 GA. WIRE WITH (2.79)/.110 MAX. INSUL. DIA.; WHEN USED WITH 2574 CONNECTOR, (2.54)/.100 MAX. INSUL. DIA. WHEN USED WITH 2139 CONNECTOR; HOUSING 41695 IS RECOMMENDED FOR OVER (2.54)/.100 DIA. INSULATION. CRIMP ACCEPTS (3.00)/.118 MAX. INSUL. DIA. WITH SPECIAL TOOLING.
 - DIMENSIONS GIVEN ACROSS CENTERLINES ARE SYMMETRICAL ABOUT THOSE CENTERLINES WITHIN HALF THE TOTAL TOLERANCE.
 -
 -
 -
 - (.86±.05)/.034±.002 IS AN OPTIONAL DESIGN.
 - THIS PART CONFORMS TO PRODUCT SPEC. 08-50.
 - CONDUCTOR CRIMP FOR 16 AWG. WIRE WITH .110 MAX. INSULATION DIA.

| | | | | | | | |
|--|-------------------------------|---|----------------------|--------------------------|---------------------|----------------------|---|
| CHANGE TO ME10 EC NO: UCP2005-0902 DRAWN BY: DRWADRATNOL 2004/11/16 CHKD BY: CHKDSAMIEC 2006/03/28 APPROVED BY: APPRMMARCOLIS 2004/10/28 | QUALITY SYMBOLS ▽=0 ▽=0 | GENERAL TOLERANCES (UNLESS SPECIFIED) | | DIMENSION STYLE IN/MM | SCALE | DESIGN UNITS INCH | THIRD ANGLE PROJECTION |
| | | 4 PLACES ±.005 ±.005 | 3 PLACES ±.005 ±.010 | 2 PLACES ±.025 ±.014 | 1 PLACE ±.036 ±.014 | ANGULAR ±1/2° | DRAWN BY: SAMIEC 06/03/86 CHECKED BY: PATEL 06/03/86 APPROVED BY: LENZ 06/03/86 |
| DRAFT WHERE APPLICABLE MUST REMAIN WITHIN DIMENSIONS | | MATERIAL NO. SEE CHART | | DOCUMENT NO. SD-2478 | | MOLEX INCORPORATED | |
| SIZE D | | THIS DRAWING CONTAINS INFORMATION THAT IS PROPRIETARY TO MOLEX INCORPORATED AND SHOULD NOT BE USED WITHOUT WRITTEN PERMISSION | | SHEET NO. 1 OF 2 | | | |

| 2478-1-(***)* | | | 2478-2-(***)* | | | 2478-3-(***)* | | | 2478-4-(***)* | | | 2478-5-(***)* | | | 2478-6-(***)* | | |
|---------------|----------------|--|---------------|----------------|--|---------------|-----------------|--|---------------|-----------------|--|---------------|-----------------|--|---------------|----------|--|
| PART NO. | ENG. NO. | | PART NO. | ENG. NO. | | PART NO. | ENG. NO. | | PART NO. | ENG. NO. | | PART NO. | ENG. NO. | | PART NO. | ENG. NO. | |
| 08-50-0105 | 2478-1-(P909) | | 08-52-0071 | 2478-3-(P909) | | 08-50-0014 | 2478-IC-(P909) | | 08-52-0044 | 2478-3C-(P909) | | 08-50-0055 | 2478-ID-(P909) | | | | |
| 08-50-0106 | 2478-1-(P909)L | | 08-52-0072 | 2478-3-(P909)L | | 08-50-0045 | 2478-IC-(P909)L | | 08-52-0045 | 2478-3C-(P909)L | | 08-50-0056 | 2478-ID-(P909)L | | | | |
| 08-56-0105 | 2478-1-(550) | | 08-65-0114 | 2478-3-(555) | | 08-50-0047 | 2478-IC-(P102) | | 08-52-0023 | 2478-3C-(102) | | | | | | | |
| 08-56-0106 | 2478-1-(550)L | | 08-65-0115 | 2478-3-(555)L | | 08-50-0046 | 2478-IC-(P102)L | | 08-52-0024 | 2478-3C-(102)L | | | | | | | |
| 08-55-0103 | 2478-1-(555) | | 08-52-0073 | 2478-3-(P102) | | 08-50-0091 | 2478-IC-(102) | | 08-52-0027 | 2478-3C-(122) | | | | | | | |
| 08-55-0104 | 2478-1-(555)L | | 08-52-0074 | 2478-3-(P102)L | | 08-50-0093 | 2478-IC-(102)L | | 08-52-0027 | 2478-3C-(122)L | | | | | | | |
| 08-50-0146 | 2478-1-(109) | | 08-52-0811 | 2478-3-(102) | | | | | 08-52-0047 | 2478-3C-(P102) | | | | | | | |
| 08-50-0147 | 2478-1-(109)L | | 08-52-0812 | 2478-3-(102)L | | | | | 08-52-0046 | 2478-3C-(P102) | | | | | | | |
| 08-50-0119 | 2478-1-(122) | | 08-50-0281 | 2478-3-(122) | | | | | | | | | | | | | |
| 08-50-0120 | 2478-1-(122)L | | | | | | | | | | | | | | | | |
| 08-50-0271 | 2478-1-(P909)A | | 08-58-0121 | 2478-3-(550) | | | | | | | | | | | | | |
| | 2478-1-(507) | | 08-58-0122 | 2478-3-(550)L | | | | | | | | | | | | | |
| | 2478-1-(507)L | | 08-58-0103 | 2478-3-(591) | | | | | | | | | | | | | |
| 08-56-0153 | 2478-1-(507) | | 08-58-0104 | 2478-3-(591)L | | | | | | | | | | | | | |
| 08-56-0154 | 2478-1-(506) | | 08-58-0114 | 2478-3-(558) | | | | | | | | | | | | | |
| | 2478-1-(506)L | | 08-58-0115 | 2478-3-(558)L | | | | | | | | | | | | | |
| 08-50-0015 | 2478-1-(102) | | | | | | | | | | | | | | | | |
| 08-50-0016 | 2478-1-(102)L | | | | | | | | | | | | | | | | |
| 08-52-0114 | 2478-1-(P909) | | | | | | | | | | | | | | | | |
| 08-52-0115 | 2478-1-(P909)L | | | | | | | | | | | | | | | | |
| | 2478-1-(132) | | | | | | | | | | | | | | | | |
| | 2478-1-(132)L | | | | | | | | | | | | | | | | |
| 08-50-0001 | 2478-1-(P224) | | | | | | | | | | | | | | | | |
| 08-50-0006 | 2478-1-(P224)L | | | | | | | | | | | | | | | | |
| 08-50-0063 | 2478-1-(224) | | | | | | | | | | | | | | | | |
| 08-50-0064 | 2478-1-(224)L | | | | | | | | | | | | | | | | |
| 08-55-0133 | 2478-1-(561) | | | | | | | | | | | | | | | | |
| 08-55-0134 | 2478-1-(561)L | | | | | | | | | | | | | | | | |
| 08-50-0073 | 2478-1-(P102) | | | | | | | | | | | | | | | | |
| 08-50-0074 | 2478-1-(P102)L | | | | | | | | | | | | | | | | |

| | | | | | | | |
|-------------|-------------|--|--|--|--|--|--------------------------------|
| SEE SHEET I | SEE SHEET I | DIMENSIONS SHOWN ARE IN INCH UNLESS OTHERWISE SPECIFIED DIMENSIONS ARE IN MILLIMETERS 1 INCH = 25.4 MM 1 MILLIMETER = 0.03937 INCH | REVISIONS: LTR, REVISIONS | REVISIONS: LTR, REVISIONS | DIMENSIONS SHOWN ARE IN INCH UNLESS OTHERWISE SPECIFIED DIMENSIONS ARE IN MILLIMETERS 1 INCH = 25.4 MM 1 MILLIMETER = 0.03937 INCH | CRIMP TERMINAL .156 18/24 AWG WIRE | DATE: 06/12/86 SHEET NO.: 2 |
| SEE SHEET I | SEE SHEET I | | DIMENSIONS SHOWN ARE IN INCH UNLESS OTHERWISE SPECIFIED DIMENSIONS ARE IN MILLIMETERS 1 INCH = 25.4 MM 1 MILLIMETER = 0.03937 INCH | DIMENSIONS SHOWN ARE IN INCH UNLESS OTHERWISE SPECIFIED DIMENSIONS ARE IN MILLIMETERS 1 INCH = 25.4 MM 1 MILLIMETER = 0.03937 INCH | CRIMP TERMINAL .156 18/24 AWG WIRE | DATE: 06/12/86 SHEET NO.: 2 | |
| SEE SHEET I | SEE SHEET I | | DIMENSIONS SHOWN ARE IN INCH UNLESS OTHERWISE SPECIFIED DIMENSIONS ARE IN MILLIMETERS 1 INCH = 25.4 MM 1 MILLIMETER = 0.03937 INCH | DIMENSIONS SHOWN ARE IN INCH UNLESS OTHERWISE SPECIFIED DIMENSIONS ARE IN MILLIMETERS 1 INCH = 25.4 MM 1 MILLIMETER = 0.03937 INCH | CRIMP TERMINAL .156 18/24 AWG WIRE | DATE: 06/12/86 SHEET NO.: 2 | |
| SEE SHEET I | SEE SHEET I | | DIMENSIONS SHOWN ARE IN INCH UNLESS OTHERWISE SPECIFIED DIMENSIONS ARE IN MILLIMETERS 1 INCH = 25.4 MM 1 MILLIMETER = 0.03937 INCH | DIMENSIONS SHOWN ARE IN INCH UNLESS OTHERWISE SPECIFIED DIMENSIONS ARE IN MILLIMETERS 1 INCH = 25.4 MM 1 MILLIMETER = 0.03937 INCH | CRIMP TERMINAL .156 18/24 AWG WIRE | DATE: 06/12/86 SHEET NO.: 2 | |
| SEE SHEET I | SEE SHEET I | | DIMENSIONS SHOWN ARE IN INCH UNLESS OTHERWISE SPECIFIED DIMENSIONS ARE IN MILLIMETERS 1 INCH = 25.4 MM 1 MILLIMETER = 0.03937 INCH | DIMENSIONS SHOWN ARE IN INCH UNLESS OTHERWISE SPECIFIED DIMENSIONS ARE IN MILLIMETERS 1 INCH = 25.4 MM 1 MILLIMETER = 0.03937 INCH | CRIMP TERMINAL .156 18/24 AWG WIRE | DATE: 06/12/86 SHEET NO.: 2 | |
| SEE SHEET I | SEE SHEET I | | DIMENSIONS SHOWN ARE IN INCH UNLESS OTHERWISE SPECIFIED DIMENSIONS ARE IN MILLIMETERS 1 INCH = 25.4 MM 1 MILLIMETER = 0.03937 INCH | DIMENSIONS SHOWN ARE IN INCH UNLESS OTHERWISE SPECIFIED DIMENSIONS ARE IN MILLIMETERS 1 INCH = 25.4 MM 1 MILLIMETER = 0.03937 INCH | CRIMP TERMINAL .156 18/24 AWG WIRE | DATE: 06/12/86 SHEET NO.: 2 | |