

Product availability: Non-Stock - Not normally stocked in distribution facility



Main

Range of product	Harmony XAC
Product or component type	Pendant control station
Device short name	XACA

Complementary

Control station type	Double insulated
Enclosure material	Polypropylene
Electrical circuit type	Control circuit
Enclosure type	Complete ready for use
Control station application	Control of single speed hoist motor
Control station composition	8 push-buttons
Control button type	First pushbutton 1 NC + 1 NO raise, slow Second pushbutton 1 NC + 1 NO lower, slow Fourth pushbutton 1 NC + 1 NO left, slow Third pushbutton 1 NC + 1 NO right, slow Fifth pushbutton 1 NC + 1 NO forward slow Sixth pushbutton 1 NC + 1 NO reverse, slow Eighth push-button 1 NC + 1 NO O Seventh pushbutton 1 NC + 1 NO I
Product compatibility	ZB2BE102 + ZB2BE101 for each direction
Mechanical interlocking	With mechanical interlocking between pairs
Control station colour	Yellow
Connections - terminals	Screw clamp terminals 1 x 0.5...2 x 1.5 mm ² with cable end Screw clamp terminals 1 x 0.5...1 x 2.5 mm ² without cable end
Standards	UL 508 EN/IEC 60204-32 CSA C22.2 No 14 EN/IEC 60947-5-1
Product certifications	CCC GOST
Protective treatment	TH
Ambient air temperature for operation	-13...158 °F (-25...70 °C)
Ambient air temperature for storage	-40...158 °F (-40...70 °C)
Vibration resistance	15 gn 10...500 Hz IEC 60068-2-6
Shock resistance	100 gn IEC 60068-2-27
Overvoltage category	Class II IEC 61140
IP degree of protection	IP65 IEC 60529
IK degree of protection	IK08 EN 50102
Mechanical durability	1000000 cycles
Cable entry	Rubber sleeve with stepped entry 8...26 mm
Contact code designation	A600 AC-15 240 V 3 A IEC 60947-5-1 appendix A A600 AC-15 600 V 1.2 A IEC 60947-5-1 appendix A Q600 DC-13 250 V 0.27 A IEC 60947-5-1 appendix A Q600 DC-13 600 V 0.1 A IEC 60947-5-1 appendix A

The information provided in this documentation contains general descriptions and/or technical characteristics of the performance of the products contained herein. This documentation is not intended as a substitute for and is not to be used for determining suitability or reliability of these products for specific user applications. It is the duty of any such user or integrator to perform the appropriate and complete risk analysis, evaluation and testing of the products with respect to the relevant specific application or use thereof. Neither Schneider Electric Industries SAS nor any of its affiliates or subsidiaries shall be responsible or liable for misuse of the information contained herein.

[Ithe] conventional enclosed thermal current	10 A
[Ui] rated insulation voltage	600 V 3
[Uimp] rated impulse withstand voltage	6 kV IEC 60947-1
Contact operation	Slow-break
Resistance across terminals	<= 25 MOhm
Operating force	13 N push-button
Short-circuit protection	10 A fuse protection cartridge gG
Rated operational power in W	40 W DC-13 1000000 cycles 60 cyc/mn 120 V 0.5 inductive IEC 60947-5-1 appendix C 48 W DC-13 1000000 cycles 60 cyc/mn 48 V 0.5 inductive IEC 60947-5-1 appendix C 65 W DC-13 1000000 cycles 60 cyc/mn 24 V 0.5 inductive IEC 60947-5-1 appendix C
Terminals description ISO n°1	(11-12)NC (13-14)NO
Terminal identifier	(13-14)NO (11-12)NC
Product weight	2.3 lb(US) (1.045 kg)

Ordering and shipping details

Category	22473 - PUSHBUTTON, PENDANTS
Discount Schedule	CS2
GTIN	003389110644883
Nbr. of units in pkg.	1
Package weight(Lbs)	2.2000000000000002
Returnability	N
Country of origin	MX

Offer Sustainability

Sustainable offer status	Green Premium product
RoHS (date code: YYWW)	Compliant - since 0627 - Schneider Electric declaration of conformity Schneider Electric declaration of conformity
REACH	Reference not containing SVHC above the threshold
Product environmental profile	Available
Product end of life instructions	Need no specific recycling operations
California proposition 65	WARNING: This product can expose you to chemicals including:
----- Substance 1	Nickel compounds, which is known to the State of California to cause cancer, and
----- Substance 2	Di-isodecyl phthalate (DIDP), which is known to the State of California to cause birth defects or other reproductive harm.
----- More information	For more information go to www.p65warnings.ca.gov

Contractual warranty

Warranty period	18 months
-----------------	-----------

Dimensions

Below drawing shows a product with 6 cut-outs. Select the number of cut-outs according to the product characteristics in order to get b, b1 and c dimensions.

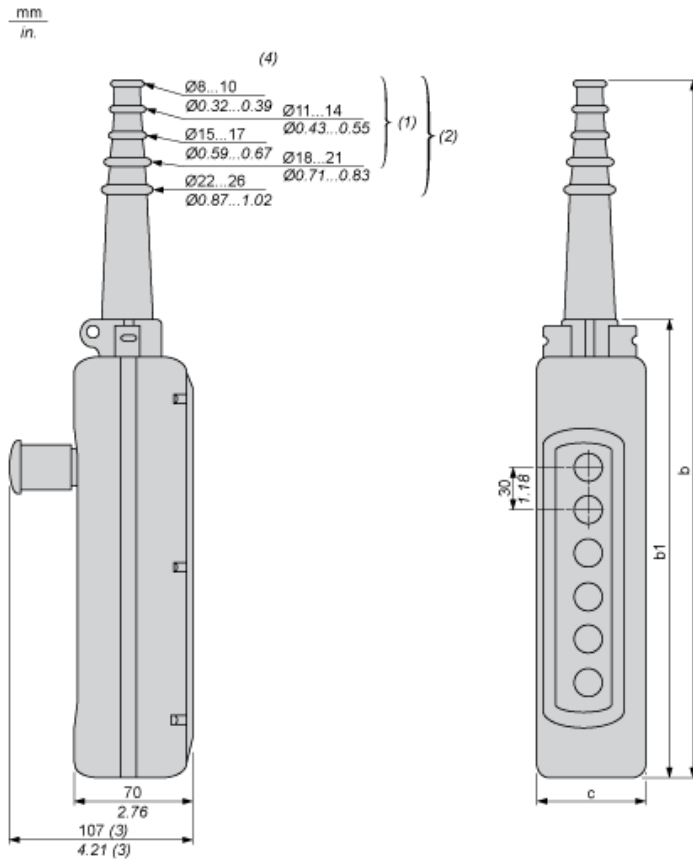

- (1) For 2 and 3-way XAC A stations.
- (2) For 4 to 8-way XAC A stations.
- (3) With trigger action Emergency stop head operator
- (4) Internal \varnothing

Dimensions in mm

Number of cut-outs	2	3	4	5	6	8	12
b	314	314	440	440	500	560	680
b1	190	190	250	250	310	370	490
c	80	80	80	80	80	80	92

Dimensions in in.

Number of cut-outs	2	3	4	5	6	8	12
b	12.36	12.36	17.32	17.32	19.68	22.05	26.77
b1	7.48	7.48	9.84	9.84	12.20	14.57	19.29
c	3.15	3.15	3.15	3.15	3.15	3.15	3.62

Control of Single-Speed Reversing Motor

With ZBE2BE101 + ZB2BE102 contacts blocks, to be ordered separately

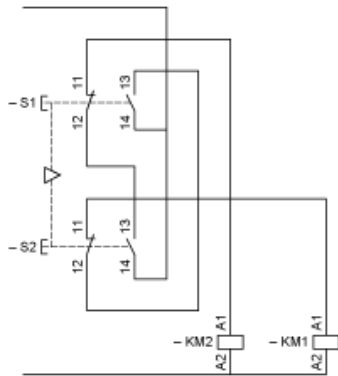

Rated Operational Power

AC Supply 50/60 Hz Inductive Circuit

Operating rate: 3600 operating cycles/hour. Load factor: 0.5.

Millions of operating cycles, AC-15 utilization category

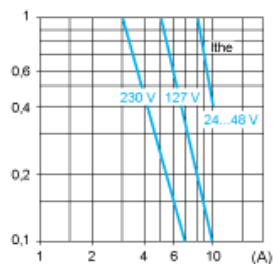

Ithe Thermal current
(A) Current

DC Supply

Operating rate: 3600 operating cycles/hour. Load factor: 0.5.

Power broken in W for 1 million operating cycles, DC-13 utilization category

Voltage	V	24	48	120
Inductive circuit	W	65	48	40