

Plug-in Signal Conditioners K-UNIT

FREQUENCY TRANSDUCER

(self-powered)

Functions & Features

- Providing a DC output signal in proportion to deviation (± 5 Hz) from center frequency (50 Hz or 60 Hz)
- DC output containing little ripple is ideal for computer input
- Isolation up to 2000 V AC
- High-density mounting
- No auxiliary power source required

Typical Applications

- Centralized monitoring and control of power management system in manufacturing facility or building
- Measuring frequency for UPS

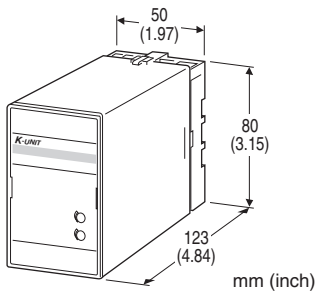

MODEL: KEHZN-[1][2][3][4]

ORDERING INFORMATION

- Code number: KEHZN-[1][2][3][4]
- Specify a code from below for each of [1] through [4].
(e.g. KEHZN-11A/Q)
- Special output range (For codes Z & 0)
 - Specify the specification for option code /Q
(e.g. /C01/S01)

[1] INPUT

- 1: 45 - 55 Hz
- 2: 55 - 65 Hz
- 3: 45 - 65 Hz

[2] INPUT

- 1: 110 V AC
- 2: 220 V AC

[3] OUTPUT

Current

- A: 4 - 20 mA DC (Load resistance 600 Ω max.)
- D: 0 - 20 mA DC (Load resistance 600 Ω max.)
- E: 0 - 16 mA DC (Load resistance 750 Ω max.)
- F: 0 - 10 mA DC (Load resistance 1200 Ω max.)
- G: 0 - 1 mA DC (Load resistance 12 k Ω max.)
- J: 0 - 5 mA DC (Load resistance 2400 Ω max.)
- Z: Specify current (See OUTPUT SPECIFICATIONS)

Voltage

- 1: 0 - 10 mV DC (Load resistance 10 k Ω min.)
 - 2: 0 - 100 mV DC (Load resistance 100 k Ω min.)
 - 3: 0 - 1 V DC (Load resistance 1000 Ω min.)
 - 4: 0 - 10 V DC (Load resistance 10 k Ω min.)
 - 5: 0 - 5 V DC (Load resistance 5000 Ω min.)
 - 6: 1 - 5 V DC (Load resistance 5000 Ω min.)
- 0: Specify voltage (See OUTPUT SPECIFICATIONS)

[4] OPTIONS

blank: none

/Q: With options (specify the specification)

SPECIFICATIONS OF OPTION: Q (multiple selections)

COATING (For the detail, refer to M-System's web site.)

- /C01: Silicone coating
- /C02: Polyurethane coating
- /C03: Rubber coating

TERMINAL SCREW MATERIAL

/S01: Stainless steel

GENERAL SPECIFICATIONS

Construction: Plug-in

Connection: M3.5 screw terminals

Screw terminal: Chromated steel (standard) or stainless steel

Housing material: Flame-resistant resin (black)

Isolation: Input to output

Computation: One-shot

Overrange output: Approx. -10 to +120 % at 1 - 5 V

Zero adjustment: -5 to +5 % (front)

Span adjustment: 95 to 105 % (front)

INPUT SPECIFICATIONS

Input burden: 3 VA

Overload capacity: 110 % of rating (continuous)

Operational range: 85 - 110 % of rating

OUTPUT SPECIFICATIONS

■ **DC Current:** 0 - 20 mA DC

Minimum span: 1 mA

Offset: Max. 1.5 times span

Load resistance: Output drive 12 V max.

■ **DC Voltage:** 0 - 12 V DC

Minimum span: 5 mV

Offset: Max. 1.5 times span

Load resistance: Output drive 1 mA max.; at ≥ 0.5 V

■ **OPERATION DIAGRAM (example)**

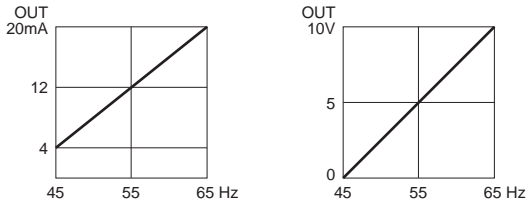

INSTALLATION

Operating temperature: -10 to +55°C (14 to 131°F)

Operating humidity: 30 to 85 %RH (non-condensing)

Mounting: Surface or DIN rail

Weight: 300 g (0.66 lb)

PERFORMANCE in percentage of span

Accuracy: ± 1 % (at 23°C ± 10 °C or 73.4°F ± 18 °F)

Response time: ≤ 1 sec. (0 - 100 % ± 1 %)

Ripple: 0.5 %p-p max.

Insulation resistance: ≥ 100 M Ω with 500 V DC

Dielectric strength: 2000 V AC @1 minute

(input to output to ground)

Impulse withstand voltage: 1.2 / 50 μ sec., ± 5 kV

(input to output or ground)

CONNECTION DIAGRAM

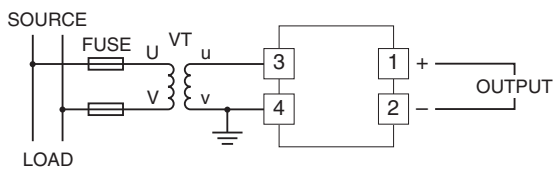

EXTERNAL DIMENSIONS & TERMINAL ASSIGNMENTS unit: mm (inch)

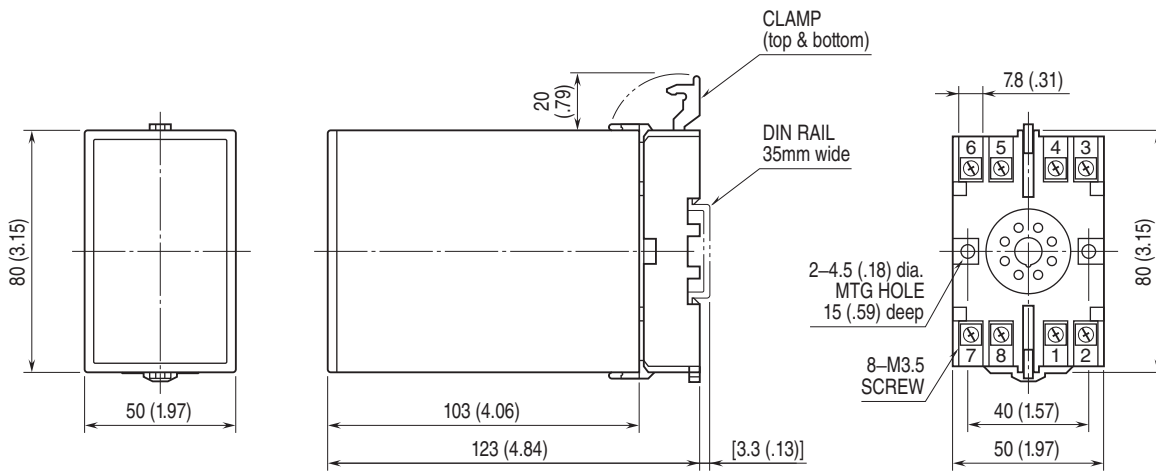

• When mounting, no extra space is needed between units.



Specifications are subject to change without notice.