

COMMON DIMENSIONS		
A	0.64	±0.05
A1	0.19	±0.03
A2	0.45	REF
A3	0.025	BASIC
b	∅0.27	±0.03
D1	1.20	BASIC
E1	1.20	BASIC
e	0.40	BASIC
SD	0.20	BASIC
SE	0.20	BASIC

SIDE VIEW

TOP VIEW

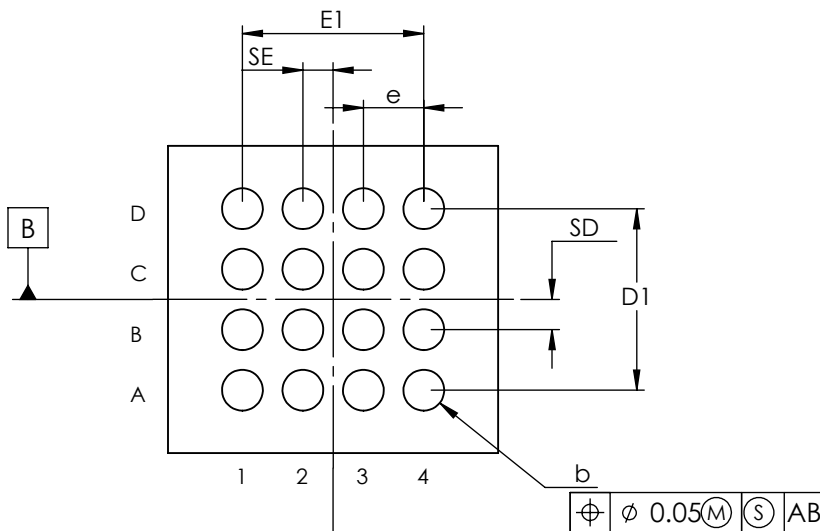

BOTTOM VIEW

PKG. CODE	E	D	DEPOPULATED BUMPS
W161B1+1	1.660±0.020	1.660±0.020	NONE
W161C1+1	1.895±0.015	1.795±0.015	NONE
W162E2+1	2.145±0.015	1.995±0.015	NONE
W161D1+1	1.824±0.015	1.824±0.015	NONE
W161A2+1	1.997±0.025	1.947±0.025	NONE

NOTES:

1. Terminal pitch is defined by terminal center to center value.
2. Outer dimension is defined by center lines between scribe lines.
3. All dimensions in millimeter.
4. Marking shown is for package orientation reference only.
5. Tolerance is ± 0.02 unless specified otherwise.
6. All dimensions apply to PbFree (+) package codes only.
7. Front - side finish can be either Black or Clear.

-DRAWING NOT TO SCALE-

 maxim integrated™			
TITLE PACKAGE OUTLINE 16 BUMPS WLP PKG. 0.4mm PITCH			
APPROVAL	DOCUMENT CONTROL NO. 21-0491	REV. G	1/1