



240-790-069

## Series 79 Filtered Cable Receptacle with Solder Cup Termination

### How To Order Filter Series 79 Connectors

<b>Sample Part Number</b>	<b>240-790-069</b>	<b>P</b>	<b>H-66</b>	<b>ME</b>	<b>P</b>	<b>D</b>	<b>P</b>
<b>Series</b>	<b>240-790-069</b>						
<b>Contact Type</b>	<b>P - Pin Contacts</b>						
<b>Insert Arrangement</b>	(See Table I)						
<b>Shell Material/Finish</b>	<b>Aluminum Shell</b> <b>ME</b> - Electroless Nickel <b>MT</b> - Nickel-PTFE <b>E</b> - Chem Film <b>Z2</b> - Gold <b>UC</b> - Zinc Cobalt with Black Chromate <b>J</b> - Cadmium with Yellow Chromate <b>NF</b> - Cad/O.D. over Electroless Nickel						
<b>Filter Type</b>	<b>C</b> - C Filter <b>P</b> - Pi Filter						
<b>Filter Class</b>	<b>X, Y, Z, A, B, C, D, E, F, G, J</b> (See Table II)						
<b>Mating Hardware Options</b>	<b>L</b> - Low-Profile Captive Jackscrew <b>K</b> - Extended Captive Jackscrew <b>N</b> - No Mating Hardware <b>P</b> - Jackposts <b>S</b> - Low-Profile Captive Screwlock <b>T</b> - Extended Captive Screwlock (See Table III)						

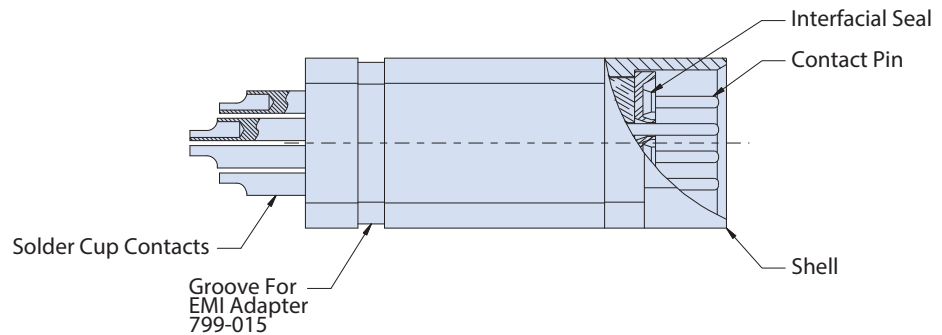
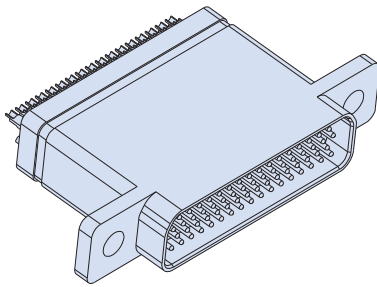

### Notes

1. Assembly to be identified with Glenair's name, part number, and date code, space permitting
2. EMI Filtered receptacle connector designed to meet requirements of MIL-STD-2120 and Glenair Series 79 specifications. Unless otherwise specified herein, refer to Glenair specification 799-008 for additional performance characteristics.
3. All contacts to have identical filter value. Other filter arrangements available, contact factory
4. Dielectric Withstanding Voltage: 500 VDC (Filter Class X, Y, Z are 250 VDC)
5. Insulation Resistance: 5,000 megohms @ 200 VDC

### 6. Current Carrying Capacity

- 23 Gage - 5 Amps max. for all layouts
- 16 Gage - 7.5 Amps max. for combo layouts / 13 Amps max. for all-power layouts
- 12 Gage - 13 Amps max. for combo layouts / 23 Amps max. for all-power layouts

7. Other filter styles (C-L, L-C, Unbalanced Pi, Multi-Stage, Multi-Value) are available. Please consult factory with your requirements.

### Materials/Finishes:

Insulators - High Grade Rigid Dielectric / N.A.  
 Interfacial Seal - Fluorosilicone Elastomer / N.A.  
 Contacts - Copper Alloy / 50 microinches Gold over Nickel  
 Mating Hardware - 300 Series Stainless Steel / Passivated

Dimensions in inches (millimeters) and are subject to change without notice.

240-790-069

Series 79 Filtered Filtered Cable Receptacle  
with Solder Cup Termination



Series 79  
Micro-Crimp

Table I: Contact Arrangements

Layout	Contact Quantity			Face View
	#23	#16	#12	
A-5	5			
B-2P2		2		
B-9	9			
C-13	13			
D-15	15			
D-3P3		3		
D-7P2	5	2		
E-11P2	9	2		
E-19	19			
E-7P3	4	3		
F-15P2	13	2		
F-23	23			
F-5P5		5		
G-33	33			
H-10P4	6		4	
H-29P7	22	7		
H-36P2	34		2	
H-54P2	52	2		
H-5P5			5	
H-66	66			
J-17P4	13	4		
J-25P2	23	2		
J-33	33			
J-7P7		7		
K-27P4	23	4		
K-35P2	33	2		
K-43	43			
K-9P9		9		
L-6P6			6	
L-78	78			
M-102	102			

Table II: Capacitor Array Code / Capacitance Range

Class	Pi - Circuit (pF)	C - Circuit (pF)
X*†	160,000 - 240,000	80,000 - 120,000
Y*	80,000 - 120,000	40,000 - 60,000
Z*	60,000 - 90,000	30,000 - 45,000
A	38,000 - 56,000	19,000 - 28,000
B	32,000 - 45,000	16,000 - 22,500
C	18,000 - 33,000	9,000 - 16,500
D	8,000 - 12,000	4,000 - 6,000
E	3,300 - 5,000	1,650 - 2,500
F	800 - 1,300	400 - 650
G	400 - 600	200 - 300
J	70-120	35-60

\* Filter Classes X, Y and Z are 250 VDC.  
All others are 500 VDC  
† Class X filters not available for insert arrangements with 3 or more rows of contacts

G

Table III: Jackscrew, Screwlock, and Jackpost Options

L	K	S	T	P
Low-Profile Captivated Jackscrew, Allen Head	Extended Captivated Jackscrew, Knurled Slot Head	Low-Profile Captivated Screwlock, Allen Head	Extended Captivated Screwlock, Knurled Slot Head	Jackpost with Nut and Split Washer

Notes:  
1. Thread size is #2-56 for shell sizes A, B, C, D, E, F, G, J, K; #4-40 for shell sizes H and L; #6-32 for shell size M.  
2. Screwlocks allow full mating of the connectors before the screws are fastened. Jackscrews must be tightened to mate the connectors.

Dimensions in inches (millimeters) and are subject to change without notice.

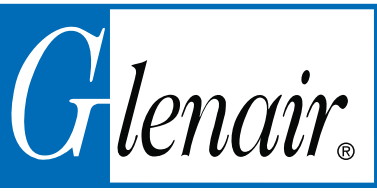

240-790-069P SHELL SIZE A, B, C, D, E, F, J AND K DIMENSIONS

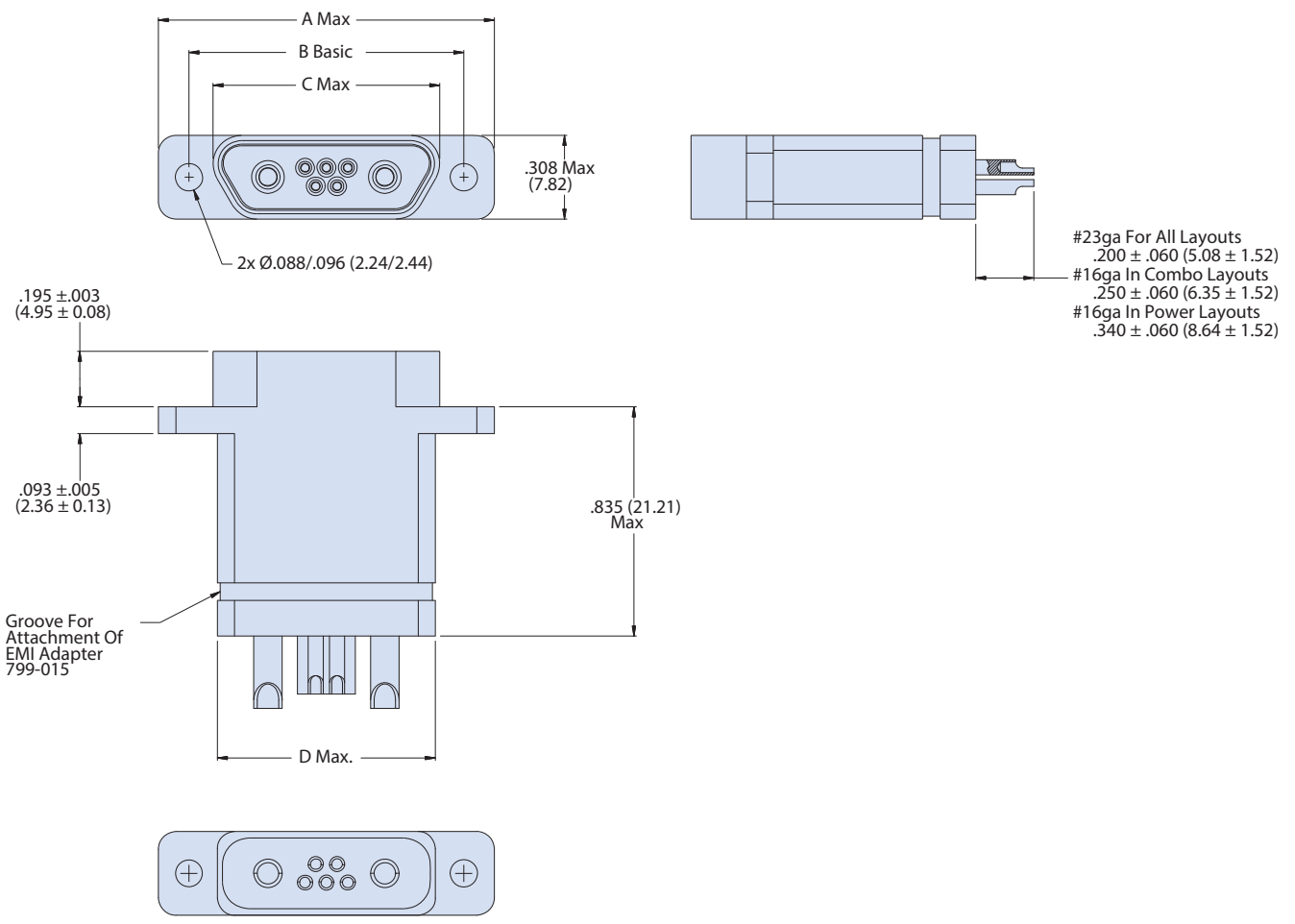

Shell Sizes A,B,C,D,E,F,J,K

790-069P Dimensions for Size A-F, J and K								
Shell Size	A Max.		B Basic		C Max		D Max	
	In.	mm.	In.	mm.	In.	mm.	In.	mm.
A	.785	19.94	.565	14.35	.400	10.16	.390	9.91
B	.935	23.75	.715	18.16	.551	14.00	.540	13.72
C	1.085	27.56	.865	21.97	.701	17.81	.690	17.53
D	1.185	30.10	.965	24.51	.801	20.35	.790	20.07
E	1.335	33.91	1.115	28.32	.951	24.16	.940	23.88
F	1.485	37.72	1.265	32.13	1.101	27.96	1.090	27.69
J	1.845	46.86	1.615	41.02	1.460	37.08	1.450	36.83
K	2.240	56.90	2.015	51.18	1.860	47.24	1.840	46.74

Dimensions in inches (millimeters) and are subject to change without notice.

240-790-069  
 Series 79 Filtered Cable Receptacle  
 with Solder Cup Termination



Series 79  
 Micro-Crimp

240-790-069P SHELL SIZE G DIMENSIONS

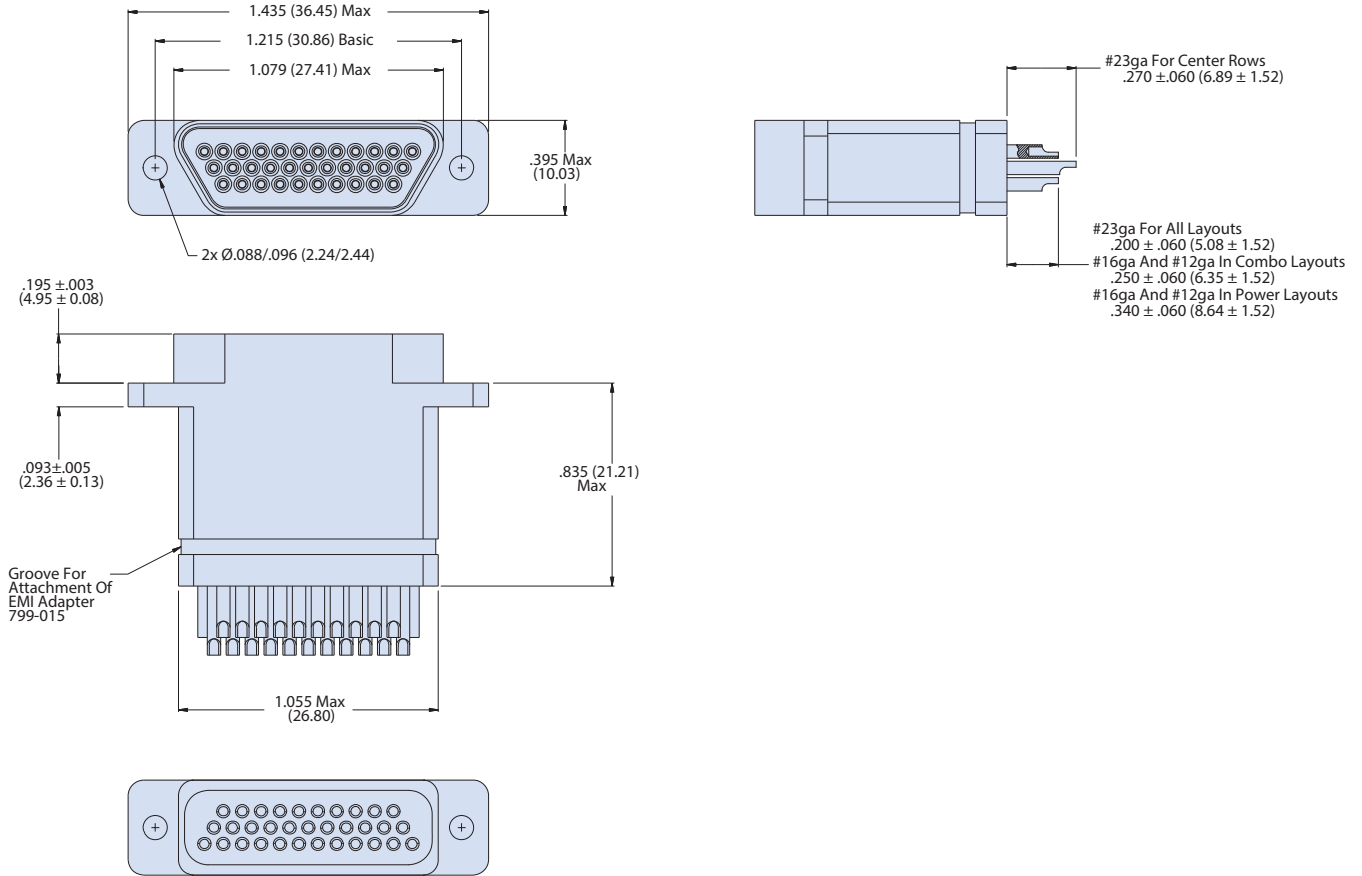

Shell Size G



Dimensions in inches (millimeters) and are subject to change without notice.

© 2013 Glenair, Inc.

U.S. CAGE Code 06324

Printed in U.S.A.

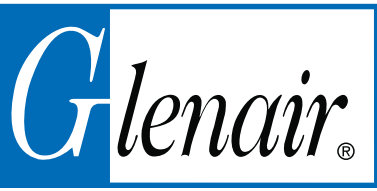

240-790-069P SHELL SIZE H AND L DIMENSIONS

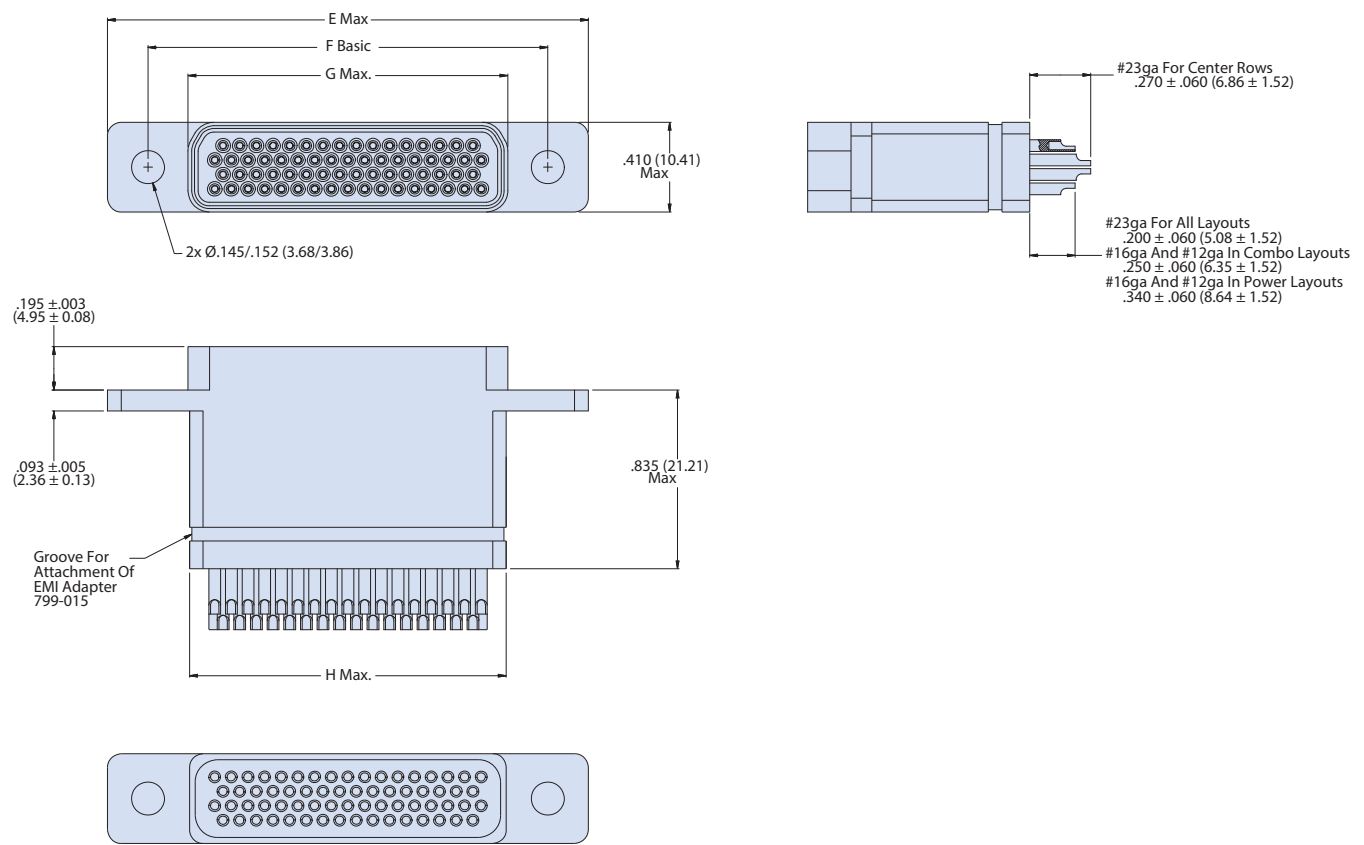

Shell Size H & L

790-069P Size H & L Dimensions								
Shell Size	E Max		F Basic		G Max		H Max	
	In.	mm.	In.	mm.	In.	mm.	In.	mm.
H	2.175	55.25	1.800	45.72	1.385	35.18	1.440	36.58
L	2.420	61.47	2.036	51.71	1.623	41.22	1.675	42.55

Dimensions in inches (millimeters) and are subject to change without notice.

240-790-069  
 Series 79 Filtered Cable Receptacle  
 with Solder Cup Termination



Series 79  
 Micro-Crimp

240-790-069P SHELL SIZE M DIMENSIONS

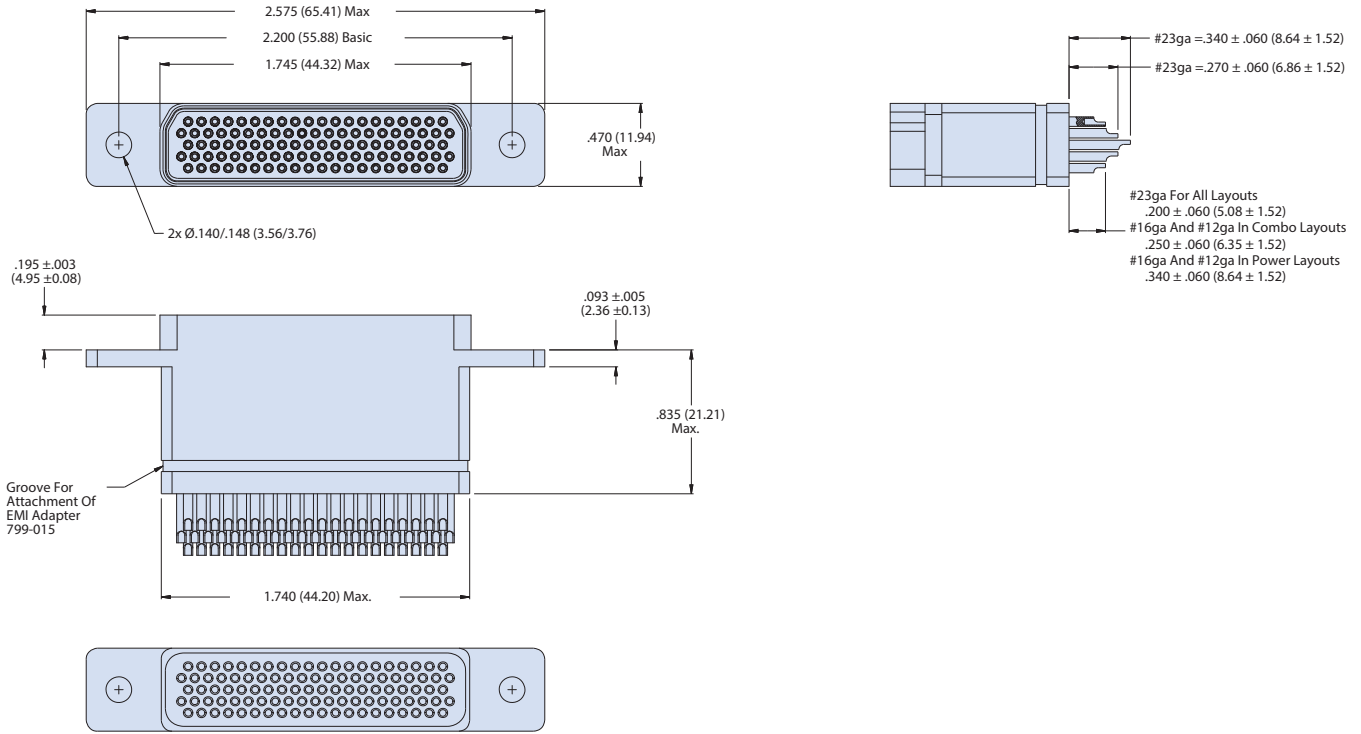

Shell Size M



Dimensions in inches (millimeters) and are subject to change without notice.

© 2013 Glenair, Inc.

U.S. CAGE Code 06324

Printed in U.S.A.