



# APPLIED CONCEPTS INC.

397 Route 281 - P.O. BOX 1175  
 Tully, New York 13159-1175  
 Phone: (315) 696-6676 Fax: (315) 696-9923  
[www.acipower.com](http://www.acipower.com)

# AC3-12-1652

PRODUCT DATA SHEET - PAGE 1 OF 2

## CCFL INVERTER (For Multiple Tube Applications)

1/10/07

### GENERAL DESCRIPTION

The AC3-12-1652 is designed to power 2 CCFL's with 6.4mA of output current yielding an output power of 3.0W per tube.

Intensity control (0-100%) is accomplished by the user providing a variable dc level at pin 6 of CON1.

Enable control is accomplished @ pin 5 of CON1.

A DC reference voltage is available @ pin 7 of CON1 for external use.

If desired, the pwm dimming frequency of the inverter can be synchronized to the LCD frame rate (Vsync) @ pin 8 of CON1.

All outputs are open and short circuit protected.

### MECHANICAL / ENVIRONMENTAL

Weight = 20 grams  
 Altitude = 10,000 Ft maximum  
 Humidity < 85% non-condensing  
 Size (L x W x H) = 5.4 IN x 0.7 IN x 0.360 IN  
 PCB thickness = 0.062 IN  
 Mounting Holes = 0.120 IN diameter (X2)  
 Input Power & Control Connector = CON1  
 CCFL Output Connectors = CON2, CON3

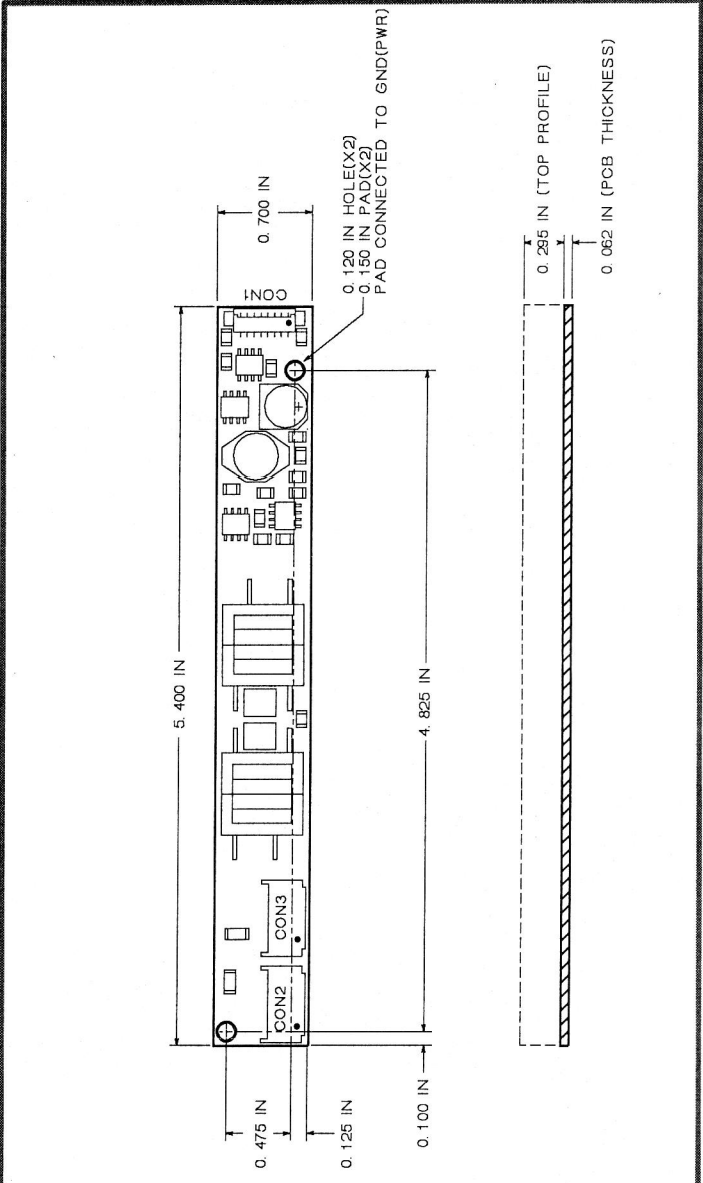

INPUT CONNECTOR CON1 MOLEX 53261-0890		OUTPUT CONNECTORS CON2, CON3 JST SM03(4.0)B-BHS-1-TB	
PIN #	FUNCTION	PIN #	FUNCTION
1	+VIN(PWR)	1	CCFL HOT
2	+VIN(PWR)	2	CCFL COLD
3	GND(PWR)		NC
4	GND(PWR)		
5	ENABLE		
6	INTENSITY CNTL		
7	+5V REF OUT		
8	VSYNC IN		

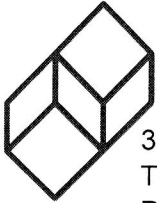

# APPLIED CONCEPTS INC.

397 Route 281 - P.O. BOX 1175  
Tully, New York 13159-1175  
Phone: (315) 696-6676 Fax: (315) 696-9923  
www.acipower.com

# AC3-12-1652

PRODUCT DATA SHEET - PAGE 2 OF 2

## MAXIMUM RATINGS\*

1/10/07

Symbol	Parameter	Value	Unit
Vin	Supply Voltage (Referenced to Ground)	-0.7 to 13.5	Vdc
Vip	Voltage applied to any Input Pin (Referenced to Ground)	-0.7 to 5.7	Vdc
Iop	Current sourced or sinked from any Output Pin	+/- 10	mAdc
Pin	Input Power (DC Input Voltage x DC Input Current)	8.25	W
Top	Operating Temperature (Still air ambient around Inverter)	0 to +70	DegC
Tstg	Storage Temperature	-40 to +150	DegC

\* Maximum Ratings are those values beyond which damage to the inverter may occur

## RECOMMENDED OPERATING CONDITIONS

Symbol	Parameter	Min	Max	Unit
Vin	Supply Voltage (Referenced to Ground)	10.8	13.2	Vdc
Lsv	Cold Cathode Fluorescent Lamp Sustaining Voltage	370	570	Vrms
Vcntl	Intensity Control Voltage	0.5	4.5	Vdc

## ELECTRICAL CHARACTERISTICS

Vin = +12V, Lsv = 470Vrms, Vcntl = +4.5V, Enable = +5V unless otherwise specified

Symbol	Parameter	Test Conditions	Min	Max	Unit
Lstart	Lamp Starting Voltage		1600		Vrms
Lout	Lamp Output Current		5.76	7.04	mArms
Lfreq	Lamp-Current Frequency		32	39	Khz
Pfreq	PWM Dimming Frequency		95	101	Hz
Pdc	PWM Duty Cycle Range	Vcntl (PIN 6) = 1.5 to +4.5V	0	100	%
ENoff	Enable Control, unit OFF (Pin 5)	Unit OFF (PIN 5)		0.7	Vdc
ENon	Enable Control, unit ON (Pin 5)	Unit ON (PIN 5)	3.5		Vdc
VSYlo	Vertical Sync In	LO Level (PIN 8)		1.0	Vdc
VSYhi	Vertical Sync In	HI Level (PIN8)	4.0		Vdc
+5Vout	+5V reference out (PIN 7)	10K load to ground	4.75	5.25	Vdc
Iin	Input Current Draw			0.61	Adc
Eff	Electrical Efficiency		90		%