

SMT CURRENT SENSE TRANSFORMERS

P820X Series

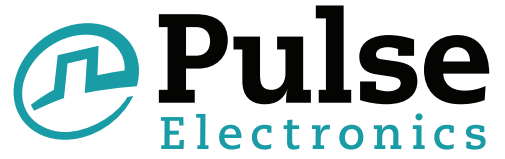

Height: 5.5mm Max

Footprint: 8.4mm x 7.2mm Max

Current Rating: up to 10A

Frequency Range: 50kHz to 1MHz

Lower Primary DCR version available: PA1005.XXX series

Electrical Specifications @ 25°C — Operating Temperature -40°C to +130°C

Part ^{6,7} Number	Turns Ratio	Current ² Rating (A)	Secondary Inductance (mH MIN)	DCR (mΩ MAX)		Hipot (V _{RMS})
				Primary (8-7)	Secondary (1-3)	
P8202NL	1:20	10	0.08	6	550	500
P8203NL	1:30	10	0.18	6	870	500
P8204NL	1:40	10	0.32	6	1140	500
P8205NL	1:50	10	0.50	6	1500	500
P8206NL	1:60	10	0.72	6	2250	500
P8207NL	1:70	10	0.98	6	4750	500
P8208NL	1:100	10	2.00	6	5500	500
P8209NL	1:125	10	3.00	6	6500	500

NOTES:

1. The temperature of the component (ambient temperature plus temperature rise) must be within the specified operating temperature range.
2. The maximum current rating is based upon temperature rise of the component and represents the DC current which will cause a typical temperature rise of 40°C with no airflow when both one turn windings connected in parallel.
3. To calculate the value of the terminating resistor (Rt) use the following formula: $R_t (\Omega) = V_{ref} * N / (I_{peak_primary})$
4. The peak flux density of the device must remain below 2000 Gauss. To calculate the peak flux density for uni-polar current use following formula:

$$B_{PK} = 37.59 * V_{REF} * (Duty_Cycle_Max) * 10^5 / (N * Freq_kHz)$$

* for bi-polar current applications divide B_{PK} (as calculated above) by 2.

5. Part numbers **P8222** to **P8229** are reverse polarity versions of **P820X**.
6. Optional Tape & Reel packaging can be ordered by adding a "T" suffix to the part number (i.e. P8202NL becomes P8202NLT). Pulse complies to industry standard tape and reel specification EIA481.
7. The "NL" suffix indicates an RoHS-compliant part number. Non-NL suffixed parts are not necessarily RoHS compliant, but are electrically and mechanically equivalent to NL versions. If a part number does not have the "NL" suffix, but an RoHS compliant version is required, please contact Pulse for availability.

Mechanical

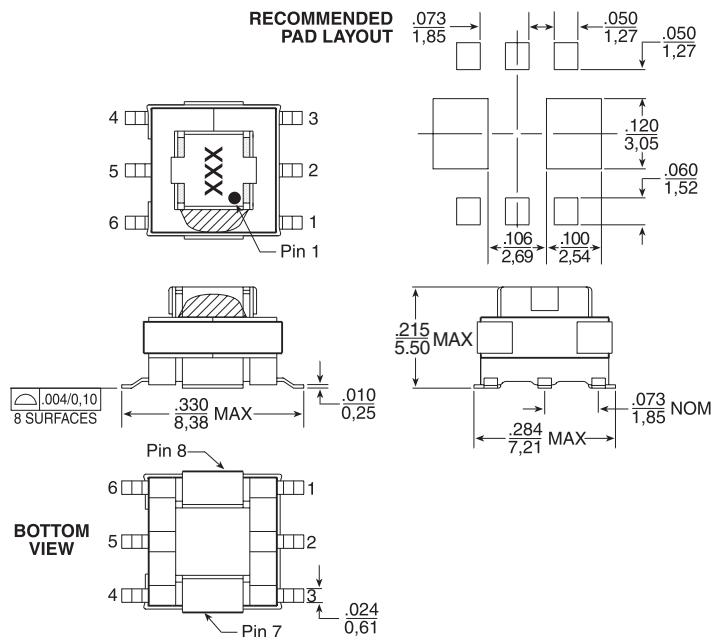

Schematic

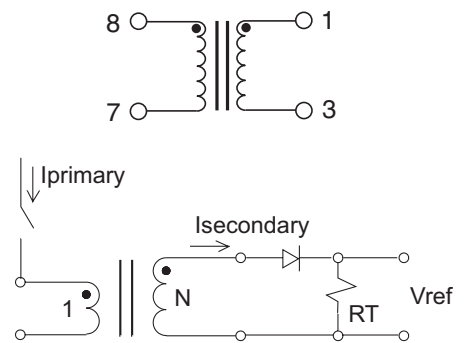

APPLICATION CIRCUIT

Weight 0.34 grams
 Tray 120/tray
 Tape & Reel 900/reel
 Coplanarity 0.004 inches

Dimensions: $\frac{\text{Inches}}{\text{mm}}$
 Unless otherwise specified, all tolerances are $\pm \frac{.010}{.025}$

Mouser Electronics

Authorized Distributor

Click to View Pricing, Inventory, Delivery & Lifecycle Information:

[Pulse:](#)

[P8204T](#) [P8206T](#) [P8205T](#) [P8208T](#) [P8203T](#) [P8209T](#) [P8202T](#) [P8202](#) [P8205](#) [P8203](#) [P8207](#) [P8209](#) [P8208](#)
[P8204](#) [P8206](#) [P8208NL](#) [P8205NLT](#) [P8207NLT](#) [P8208NLT](#) [P8203NLT](#) [P8202NLT](#) [P8206NLT](#)