

## Ultra Low Noise, Fast Response, High PSRR 700mΩ Low Dropout Linear Regulator

### General Description

The uP8804P is an ultra low noise, fast response, high power supply rejection ratio (PSRR) low dropout regulator specifically designed to continuously deliver up to 500mA output current. Designed with a P-channel MOSFET series pass transistor, the uP8804P yields extremely low dropout voltage (e.g. 210mV at 300mA, 350mV at 500mA) and maintains very low ground current (70uA).

The uP8804P does not require a bypass capacitor, hence achieving the smallest PCB area. This device reduces output voltage noise to 100uV<sub>(RMS)</sub> and improves PSRR to 40dB at 100kHz.

The uP8804P is designed and optimized to work with low-value, low-cost ceramic capacitors. Only a 1uF ceramic output capacitor is required for stable operation for any load conditions.

Other features include foldback overcurrent protection, quick soft start, and overtemperature protection. The uP8804P is available in adjustable or fixed output voltage from 0.8V to 3.3V with 0.1V per step. The device comes in SC70-5/6L, TSOT23-5L packages.

### Pin Configuration

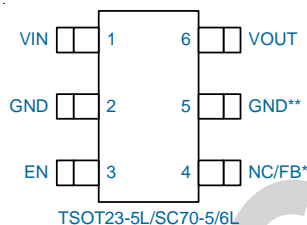

Note \*

NC for fixed output voltage and fixed soft start time;

FB for adjustable output voltage version.

Note \*\* GND for SC70-6L package only.

### Features

- Wide Input Voltage Range from 2.4 to 5.5V
- Ultra Low Dropout Voltage: 210mV @ 300mA
- High Power Supply Rejection Ratio
  - 70dB at 1kHz
  - 40dB at 100kHz
- Ultra Low Output Noise Voltage 100uV<sub>(RMS)</sub>
- Ultra Fast Response in Line/Load Transient
- Stable with 1uF Ceramic Output Capacitor
- Low Ground Current: 70uA
- Low Shutdown Current: < 1uA
- Foldback Output Current Limit
- High Output Accuracy
  - 1.0% Initial Accuracy
  - Fixed Output Voltages: 0.8V to 3.3V
  - Adjustable Output Voltage from 0.8V to 4.5V
- Over-Temperature Protection
- RoHS Compliant and Halogen Free

### Applications

- Cellular and Cordless Phones
- Bluetooth Portable Radios and Accessories
- Battery-Powered Equipment
- Laptop, Palmtops, Notebook Computers
- Hand-Held Instruments
- PCMCIA Cards
- Portable Information Appliances

Typical Application Circuit

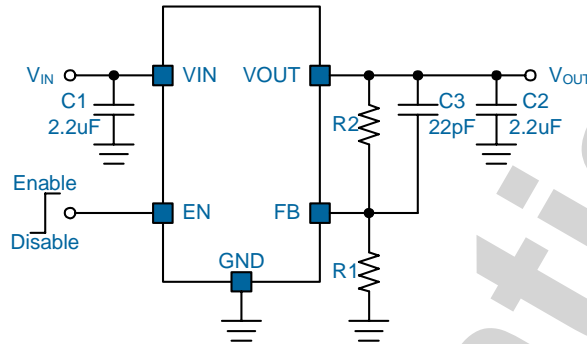

Ordering Information

Order Number	Package	Top Marking	Remark
uP8804PEC6-00	SC70-6L		Output Voltage : Adjustable
uP8804PEC6-18			Output Voltage : 1.8V
uP8804PEC5-00	SC70-5L		Output Voltage : Adjustable
uP8804PEC5-18			Output Voltage : 1.8V
uP8804PMT5-00	TSOT23-5L		Output Voltage : Adjustable
uP8804PMT5-18			Output Voltage : 1.8V

Note:

- (1) Please check the sample/production availability with uPI representatives.
- (2) uPI products are compatible with the current IPC/JEDEC J-STD-020 requirement. They are halogen-free, RoHS compliant and 100% matte tin (Sn) plating that are suitable for use in SnPb or Pb-free soldering processes.

Functional Pin Description

No.	Name	Pin Function
1	VIN	<b>Input Voltage.</b> This pin connects to the source of the internal pass transistor that supplies current to the output pin. Bypass VIN to GND with a minimum 1uF ceramic capacitor. Place the decoupling capacitor physically as close as possible to the device.
2	GND	<b>Ground.</b>
3	EN	<b>Enable Input.</b> Pulling this pin below 0.4V turns the regulator off, reducing the quiescent current to a fraction of its operating value. Pull this pin higher than 2V for normal operation.
4	NC/ FB	<b>NC: Not Internally Connected.</b> For fixed output voltage and fixed soft start time version. <b>FB: Output Voltage Feedback.</b> For adjustable output voltage version. Connect a voltage divider from output voltage to this pin to GND to set output voltage. The FB pin voltage is regulated to internal 0.8V reference voltage. Set the output voltage according to $V_{OUT} = 0.8 \times (R1 + R2) / R1$ (V).
5	GND	<b>Ground.</b> For SC70-6 package only.
6	VOUT	<b>Output Voltage.</b> This pin is power output of the device. Bypass this pin with a minimum 1uF ceramic capacitor.

*Functional Block Diagram*

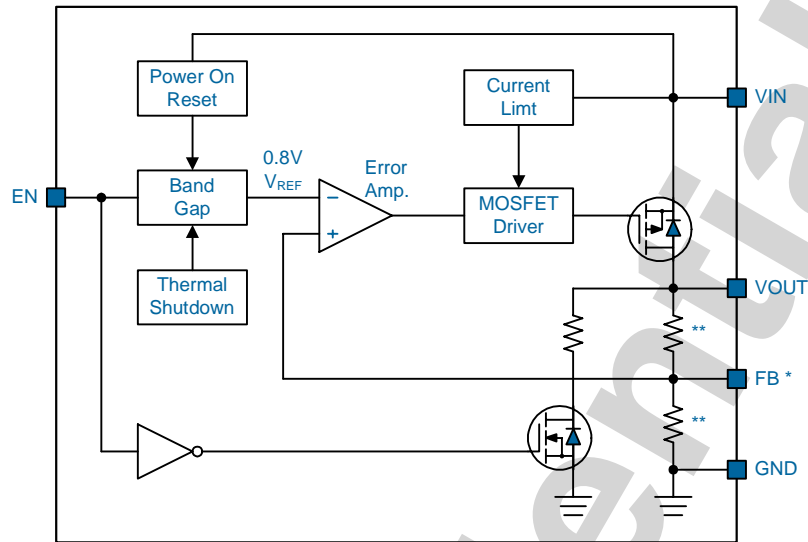

Note \*: For adjustable output voltage version only.

Note \*\*: For fixed adjustable output voltage version only.

## Functional Description

### Definitions

Some important terminologies for LDO are specified below.

### Dropout Voltage

The input/output Voltage differential at which the regulator output no longer maintains regulation against further reductions in input voltage. Measured when the output drops 2% below its nominal value, dropout voltage is affected by junction temperature, load current and minimum input supply requirements.

### Line Regulation

The change in output voltage for a change in input voltage. The measurement is made under conditions of low dissipation or by using pulse techniques such that average chip temperature is not significantly affected.

### Load Regulation

The change in output voltage for a change in load current at constant chip temperature. The measurement is made under conditions of low dissipation or by using pulse techniques such that average chip temperature is not significantly affected.

**Maximum Power Dissipation** The maximum total device dissipation for which the regulator will operate within specifications.

### Quiescent Bias Current

Current which is used to operate the regulator chip and is not delivered to the load. The quiescent current  $I_Q$  is defined as the supply current used by the regulator itself that does not pass into the load. It typically includes all bias currents required by the LDO and any drive current for the pass transistor.

The uP8804P is an ultra low noise, fast response, high power supply rejection ratio (PSRR) low dropout regulator specifically designed to continuously deliver up to 500mA output current for space-limited applications. Designed with a P-channel MOSFET series pass transistor, the uP8804P yields extremely low dropout voltage (e.g. 105mV at 150mA, 210mV at 300mA, and 350mV at 500mA) and maintain very low ground current (70uA). The uP8804P does not require a bypass capacitor, hence achieving the smallest PCB area. This device reduces output voltage noise to 100uV<sub>(RMS)</sub> and improves PSRR to 40dB at 100kHz. The uP8804P is designed and optimized to work with low-value, low-cost ceramic capacitors. Only a 1uF ceramic output capacitor is required for stable operation for any load conditions. Other features include foldback overcurrent protection, quick soft start, and overtemperature protection. The uP8804P is available in adjustable and fixed output voltages from 0.8V to 3.3V with 0.1V increments.

As shown in the *Functional Block Diagram*, the uP8804P consists of a bandgap for reference voltage, error amplifier, P-channel MOSFET pass transistor and internal feedback voltage divider. The 0.8V bandgap reference voltage is connected to the inverting input of error amplifier. The error amplifier compares this reference voltage with the feedback voltage and amplifies the difference. If the feedback voltage is lower than the reference voltage, the pass-transistor gate is pulled low. This allows more current to pass to the output and increases the output voltage. If the feedback voltage is too high, the pass transistor gate is pulled high, allowing less current to pass to the output. The output voltage is fed back through an internal resistor voltage-divider connected to the VOUT pin. Additional blocks include a current limiter, thermal sensor, and shutdown logic.

### Supply Input Power On Reset

The input voltage supplies current to the output voltage and supplies current for control circuit. The input voltage is monitored for power on reset (POR) to ensure the regulator is not enabled until the input voltage is high enough for normal operation. The POR threshold level is typical 2.3V at  $V_{IN}$  rising.

### Enable/Shutdown

The uP8804P features an active-high enable pin that allows the regulator to be disabled. Forcing the enable pin lower than 0.4V shuts down the regulator and reduces its quiescent current less than 1uA. The voltage reference, error amplifier, gate-driver circuit and pass transistor are disabled in the shutdown state.

Forcing the enable pin higher than 2V enables the output voltage (once the input voltage is higher than its POR threshold level). If the enable function is not needed in a specific application, it may be tied to  $V_{IN}$  to keep the regulator in an always on state. The enable pin uses CMOS technology and cannot be left floating, as this may cause an indeterminate state on the output.

### Current Limit and Short-Circuit Protection

The uP8804P includes a current limiter that monitors and controls the gate voltage of pass transistor to limit the output current to 500mA typically. A short circuit protector monitors the output voltage and asserts output short circuit if  $V_{OUT}$  is lower than 40% of  $V_{NOM}$ . The current limiting level is reduced to 100mA and overtemperature threshold level is lowered to 100°C when output short circuit occurs. This limits the junction temperature to a safe level and allows the output to be shorted to ground for an indefinite duration without damaging the device. The output voltage is rebuilt after short circuit is removed.

**Over Temperature Protection**

The overtemperature protection limits total power dissipation in the uP8804P. When the junction temperature exceeds  $T_j = 150^\circ\text{C}$ , the thermal sensor signal the shutdowns logic, turning off the pass transistor and allows the device to cool down. The thermal sensor turns on the pass transistor again after the device's junction temperature drops by  $30^\circ\text{C}$ , resulting in a pulsed output during continuous during continuous thermal-overload conditions. The overtemperature protection is designed to protect the device in the event of a fault condition. For continual operation, the junction temperature should not exceed the recommended temperature of  $T_j = 125^\circ\text{C}$  for maximum reliability.

UPI Confidential

### Absolute Maximum Rating

(Note 1)

Supply Input Voltage $V_{IN}$	-----	-0.3V to +6V
Other Pins	-----	-0.3V to ( $V_{IN} + 0.3V$ )
Storage Temperature Range	-----	-65°C to +150°C
Junction Temperature	-----	150°C
Lead Temperature (Soldering, 10 sec)	-----	260°C
ESD Rating (Note 2)		
HBM (Human Body Mode)	-----	2kV
MM (Machine Mode)	-----	200V

### Thermal Information

Package Thermal Resistance (Note 3)

TSOT23 - 5L $\theta_{JA}$	-----	250°C/W
TSOT23 - 5L $\theta_{JC}$	-----	100°C/W
SC70 - 5/6L $\theta_{JA}$	-----	333°C/W
SC70 - 5/6L $\theta_{JC}$	-----	185°C/W
Power Dissipation, $P_D$ @ $T_A = 25^\circ\text{C}$		
TSOT23 - 5L	-----	0.40W
SC70 - 5/6L	-----	0.30W

### Recommended Operation Conditions

(Note 4)

Operating Junction Temperature Range	-----	-40°C to +125°C
Operating Ambient Temperature Range	-----	-40°C to +85°C
Supply Input Voltage, $V_{IN}$	-----	+2.5V to +5.5V

### Electrical Characteristics

 ( $V_{IN} = 5V$ ,  $T_A = 25^\circ\text{C}$ , unless otherwise specified)

Parameter	Symbol	Test Conditions	Min	Typ	Max	Unit
<b>Supply Input Voltage</b>						
Supply Input Voltage	$V_{IN}$		2.4	--	5.5	V
POR Threshold	$V_{PORTH}$		--	2.1	2.4	V
POR Hysteresis	$V_{PORHYS}$		--	0.2	--	V
Quiescent Current	$I_Q$	$V_{EN} = 5V$ , $I_{OUT} = 0mA$	--	95	135	$\mu A$
Shutdown Current	$I_{SHDN}$	$V_{EN} = 0V$	--	0.1	1	$\mu A$
<b>Output Voltage</b>						
Output Voltage Accuracy for Fixed Version	$V_{OUT}$	$V_{IN} = V_{NOM} + 1.0V$ ; $I_{OUT} = 1mA$ ; $T_A = 25^\circ\text{C}$	-1.0	--	1.0	% $V_{NOM}$
	$V_{OUT\_TOL}$	$T_A = 0^\circ\text{C}$ to $85^\circ\text{C}$	-1.3	--	1.3	
		$T_A = -40^\circ\text{C}$ to $85^\circ\text{C}$	-1.8	--	1.8	
Reference Voltage Accuracy for Adjustable Version	$V_{REF}$	$V_{IN} = V_{NOM} + 1.0V$ ; $I_{OUT} = 1mA$ ; $T_A = 25^\circ\text{C}$	0.792	0.800	0.808	V
	$V_{REF\_TOL}$	$T_A = 0^\circ\text{C}$ to $85^\circ\text{C}$	0.790	--	0.810	
		$T_A = -40^\circ\text{C}$ to $85^\circ\text{C}$	0.785	--	0.815	

**Electrical Characteristics**

Parameter	Symbol	Test Conditions	Min	Typ	Max	Unit
<b>Output Voltage</b>						
Output Line Regulation	$\Delta V_{OUT(LINE)}$	$2.5V < V_{IN} < 5.5V, I_{OUT} = 1mA$	--	0.01	0.1	%/V
Output Load Regulation	$\Delta V_{OUT(LOAD)}$	$1mA < I_{OUT} < 500mA, V_{IN} = V_{NOM} + 1.0V$	--	0.5	1	%/A
Output Voltage Noise		10Hz to 1MHz; $C_{OUT} = 3.3\mu F, ESR < 100m\Omega$	--	100	--	$\mu V_{(RMS)}$
Power Supply Rejection Ratio	PSRR	$I_{OUT} = 300mA; 1kHz$	--	70	--	dB
		$I_{OUT} = 300mA; 100kHz$	--	40	--	
		$I_{OUT} = 300mA; 1MHz$	--	35	--	
Dropout Voltage	$V_{DROP}$	$I_{OUT} = 150mA, 2.5V < V_{NOM} < 3.3V$	--	90	135	mV
		$I_{OUT} = 300mA, 2.5V < V_{NOM} < 3.3V$	--	180	270	
		$I_{OUT} = 500mA, 2.5V < V_{NOM} < 3.3V$	--	300	450	
<b>Enable</b>						
Enable High Level	$V_{EN}$		2	--	--	V
Disable Low Level	$V_{SD}$		--	--	0.4	V
EN Input Current	$I_{EN}$	$V_{IN} = 5.5V, V_{EN} = 5.5V$ or 0V	-1	0	1	$\mu A$
Output Pull Low Resistance When Turn Off			400	700	1200	$\Omega$
<b>Soft Start</b>						
Soft Start Time	$T_{SS}$		300	500	700	$\mu s$
<b>Protection</b>						
Current Limit Threshold	$I_{LIM\_TH}$		740	1100	1650	mA
Short Circuit Current	$I_{LIM\_SC}$		480	740	1100	mA
Thermal Shutdown Temperature	$T_{SD}$	$I_{OUT} = 0mA, V_{IN} = V_{EN} = 5.5V$	--	150	--	$^{\circ}C$
Thermal Shutdown Hysteresis	$T_{SDHYS}$	$I_{OUT} = 0mA, V_{IN} = V_{EN} = 5.5V$	--	30	--	$^{\circ}C$

**Note 1.** Stresses listed as the above *Absolute Maximum Ratings* may cause permanent damage to the device. These are for stress ratings. Functional operation of the device at these or any other conditions beyond those indicated in the operational sections of the specifications is not implied. Exposure to absolute maximum rating conditions for extended periods may remain possibility to affect device reliability.

**Note 2.** Devices are ESD sensitive. Handling precaution recommended.

**Note 3.**  $\theta_{JA}$  is measured in the natural convection at  $T_A = 25^{\circ}C$  on a low effective thermal conductivity test board of JEDEC 51-3 thermal measurement standard.

**Note 4.** The device is not guaranteed to function outside its operating conditions.



## Typical Operation Characteristics

### Power On Waveform

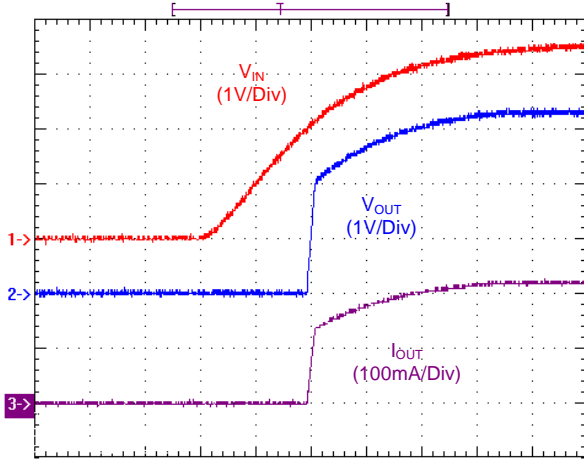

2ms/Div  
 $V_{OUT} = 3.3V, C_{OUT} = 1\mu F, R_{OUT} = 15\Omega.$

### Turn On Waveform

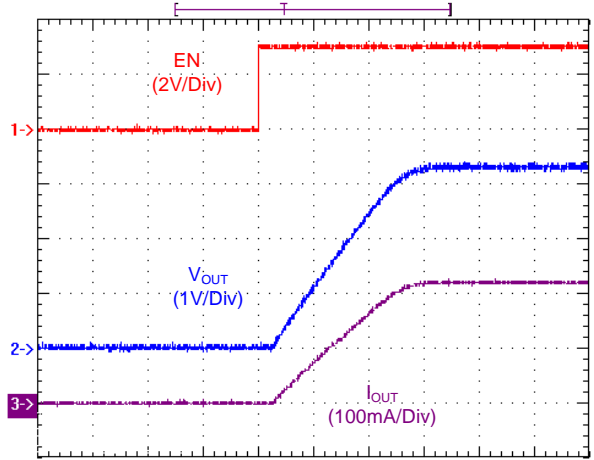

200us/Div  
 $V_{OUT} = 3.3V, C_{OUT} = 1\mu F, R_{OUT} = 15\Omega.$

### Power Off Waveform

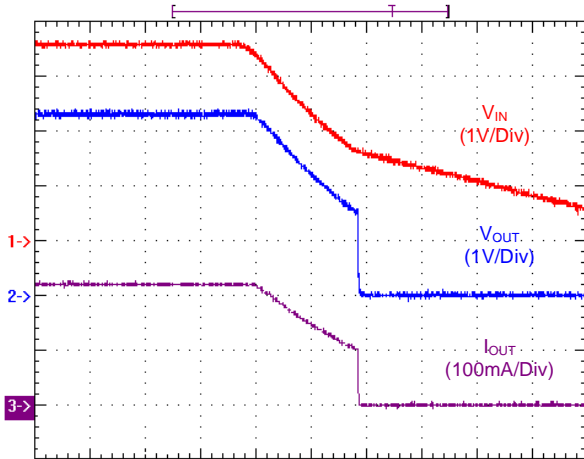

2ms/Div  
 $V_{OUT} = 3.3V, C_{OUT} = 1\mu F, R_{OUT} = 15\Omega.$

### Turn Off Waveform

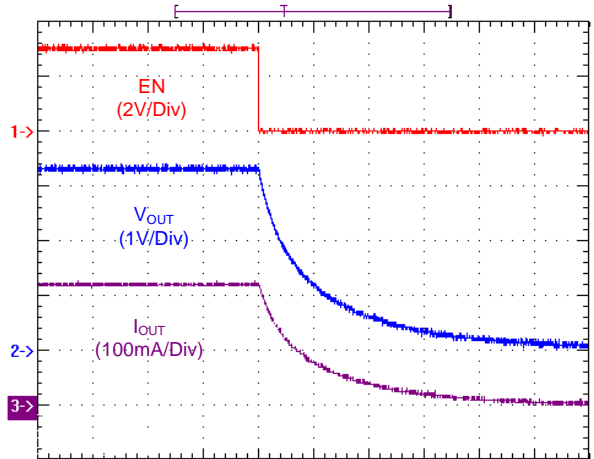

10us/Div  
 $V_{OUT} = 3.3V, C_{OUT} = 1\mu F, R_{OUT} = 15\Omega.$

### Load Transient Response

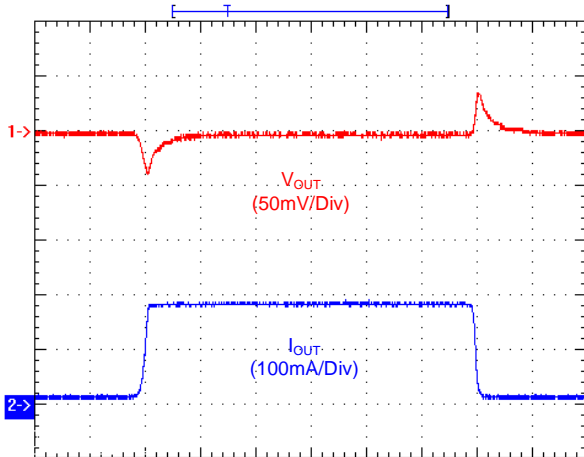

2ms/Div  
 $V_{OUT} = 3.3V, C_{OUT} = 1\mu F, I_{OUT} = 10mA \text{ to } 180mA.$

### Output Voltage vs. Temperature

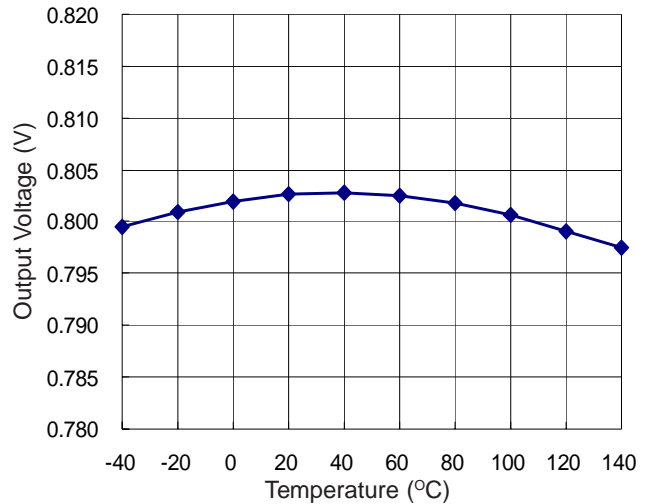



Typical Operation Characteristics

Shutdown Current vs. Temperature

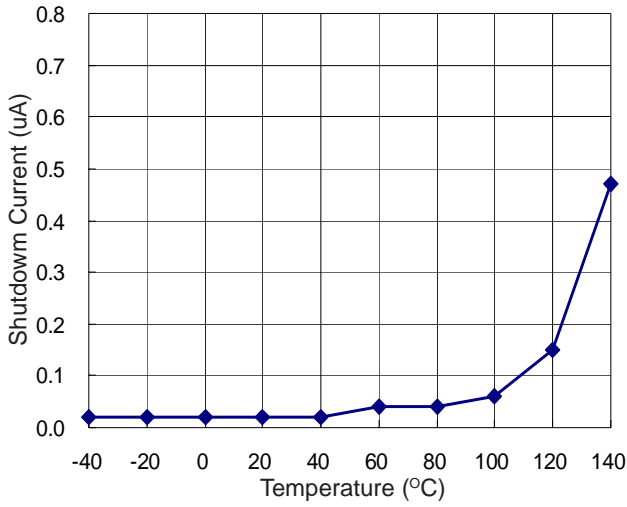

Quiescent Current vs. Temperature

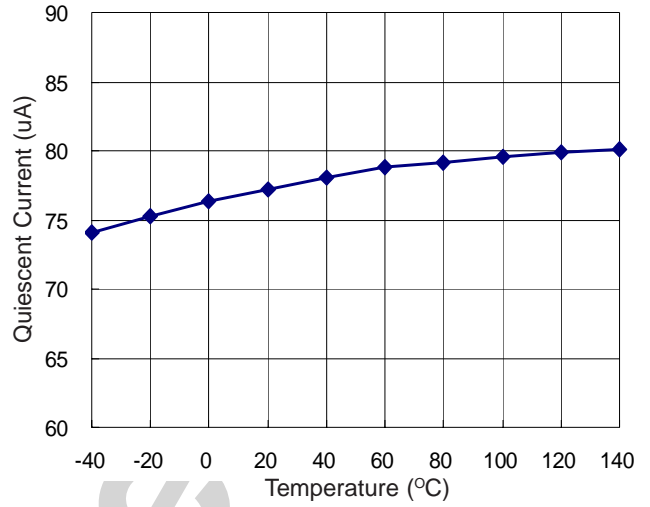

Enable/ Disable Threshold vs. Temperature

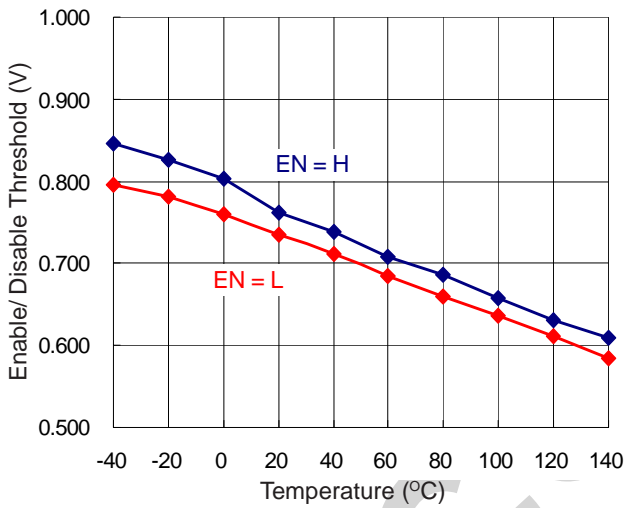

On Resistance vs. Temperature

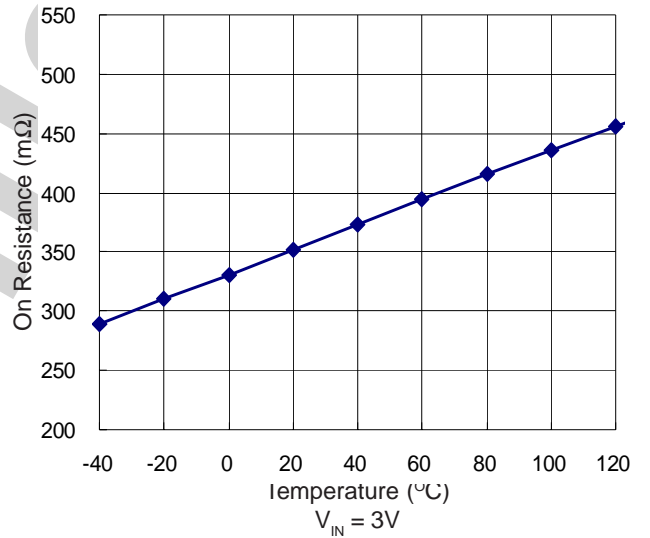

Pull Low Resistance vs. Input Voltage

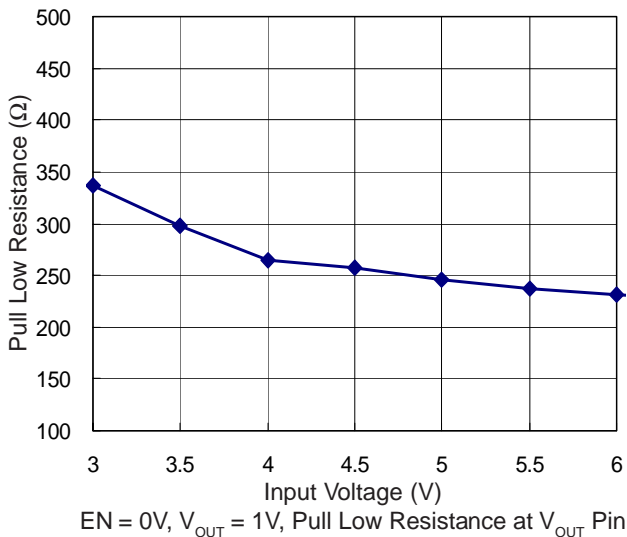

Quiescent Current vs. Input Voltage

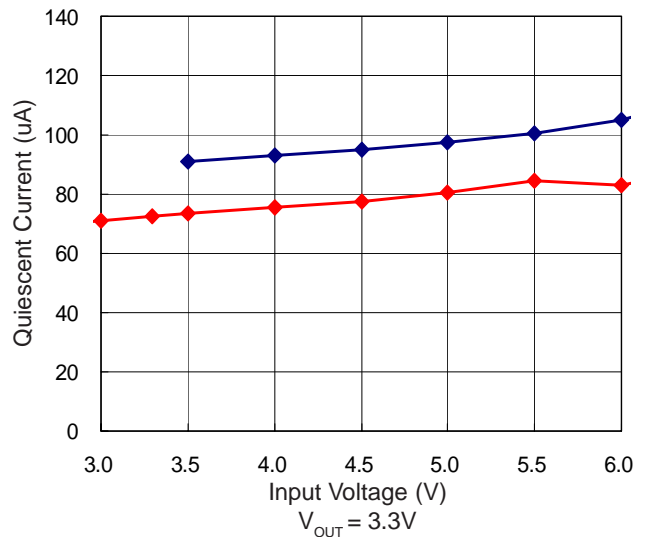

**Typical Operation Characteristics**

**Output Voltage Line Regulation**

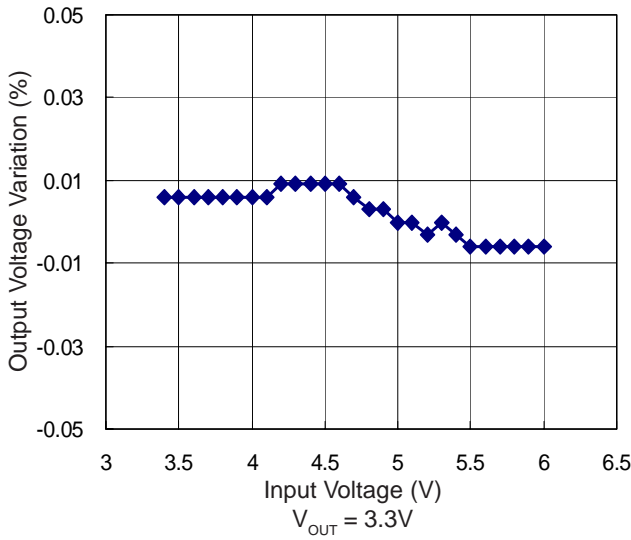

**Dropout Voltage vs. Output Current**

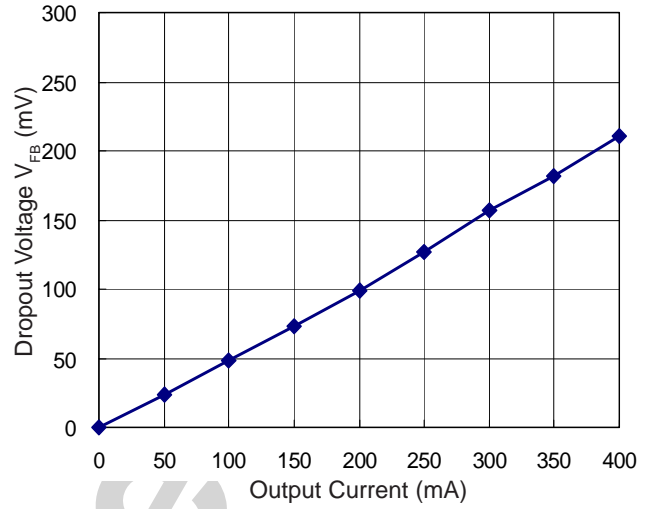

**Enable/ Disable Threshold vs. Input Voltage**

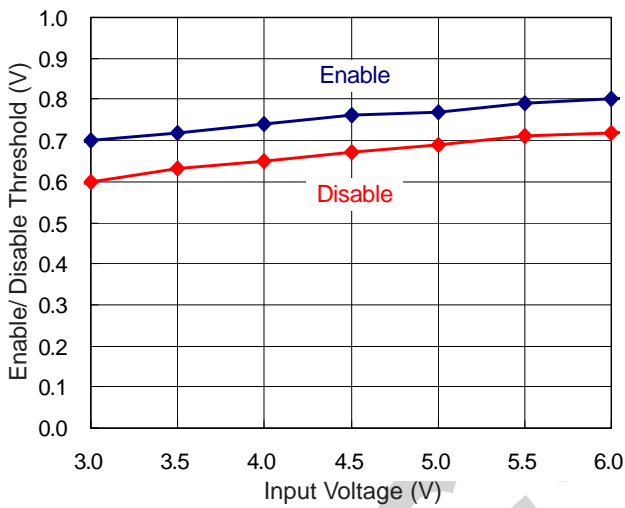

**On Resistance vs. Input Voltage**

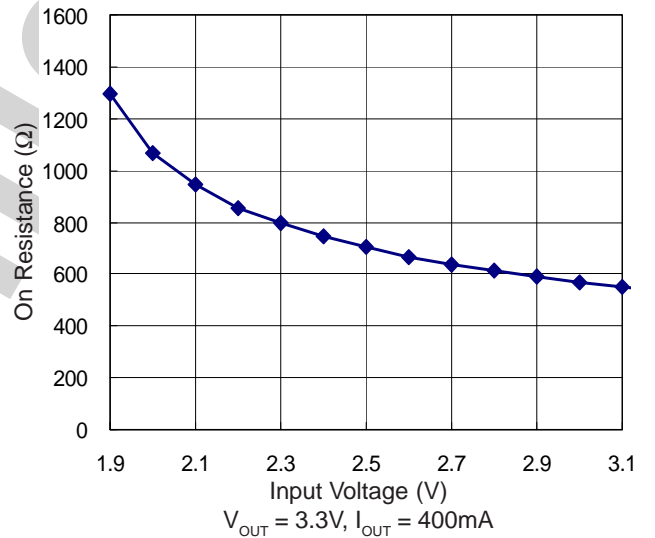

## Application Information

The uP8804P is specially designed to provide low-noise, high PSRR output voltage without a bypassing capacitor on its reference voltage. However, input and output capacitor should be well considered for optimal performance.

### Input Capacitors

The uP8804P requires well-decoupled supply input for optimal performance. A minimum 1uF capacitor is required from-input-to-ground to provide stability. Input capacitors greater than 1uF offer superior input line transient response and will assist in maximizing the highest possible power supply ripple rejection ratio (PSRR). Ceramic, tantalum, or aluminum electrolytic capacitors may be selected for CIN. There is no specific capacitor ESR requirement for CIN. However, low-ESR ceramic capacitors provide optimal performance at a minimum of space and are highly recommended due to their inherent capability over tantalum capacitors to withstand input current surges from low impedance sources such as batteries in portable devices. Additional high frequency capacitors, such as small-valued NPO dielectric type capacitors, help filter out high-frequency noise and are good design practice in any RF-based circuit. Place the capacitors physically as close as possible to the device with wide and direct PCB traces.

### Output Capacitors and Stability

For proper load voltage regulation and operational stability, a capacitor is required between VOUT and GND pins. The uP8804P is designed and optimized to work with low-value, low-cost ceramic capacitors in space saving and performance consideration. Typical output capacitor values for maximum output current conditions range from 1uF to 10uF. Larger capacitors are recommended for applications expecting low output noise and optimum power supply ripple rejection characteristics. Place the capacitors physically as close as possible to the device with wide and direct PCB traces.

X7R/X5R dielectric-type ceramic capacitors are recommended because of their temperature performance. X7R type capacitors loss capacitance by 15% over their operating temperature range and are the most stable type of ceramic capacitors. Z5U or Y5V dielectric capacitors loss their capacitance by 50% and 60% respectively over their operating temperature ranges. If Y5V or Z5U capacitors are used as output capacitors, the capacitance must be much higher than that of X7R capacitors to ensure the same minimum capacitance over the operating temperature range.

ESR of output capacitors should be well considered to ensure stable operation of the device. High ESR capacitors may cause high frequency oscillation.

### No Load Stability

The uP8804P is designed to maintain output voltage regulation and stability under operational no load conditions. This is important characteristic for CMOS RAM keep-alive applications where the output current may drop to zero.

**TSOT23-5L Package**

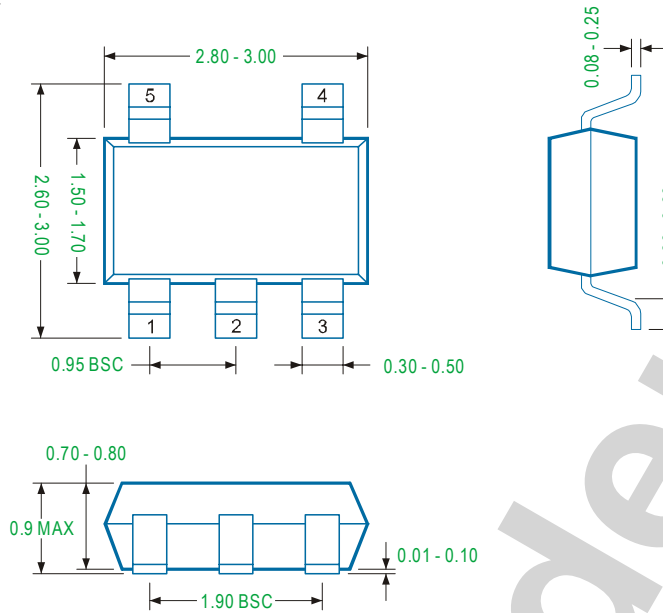

**Note**

**1. Package Outline Unit Description:**

BSC: Basic. Represents theoretical exact dimension or dimension target

MIN: Minimum dimension specified.

MAX: Maximum dimension specified.

REF: Reference. Represents dimension for reference use only. This value is not a device specification.

TYP: Typical. Provided as a general value. This value is not a device specification.

**2. Dimensions in Millimeters.**

**3. Drawing not to scale.**

**4. These dimensions do not include mold flash or protrusions. Mold flash or protrusions shall not exceed 0.15mm.**

**SC70-5L**

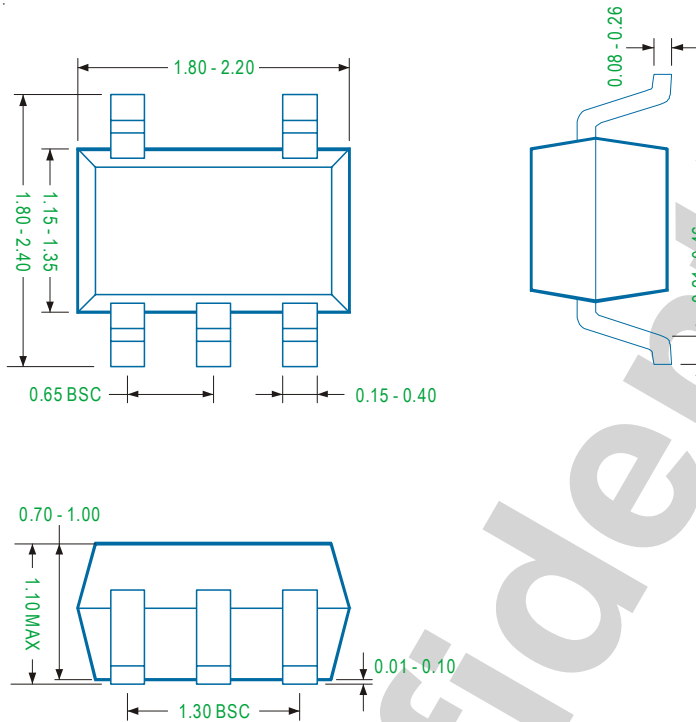

**Note**

**1. Package Outline Unit Description:**

BSC: Basic. Represents theoretical exact dimension or dimension target

MIN: Minimum dimension specified.

MAX: Maximum dimension specified.

REF: Reference. Represents dimension for reference use only. This value is not a device specification.

TYP: Typical. Provided as a general value. This value is not a device specification.

**2. Dimensions in Millimeters.**

**3. Drawing not to scale.**

**4. These dimensions do not include mold flash or protrusions. Mold flash or protrusions shall not exceed 0.15mm.**

**SC70-6L**

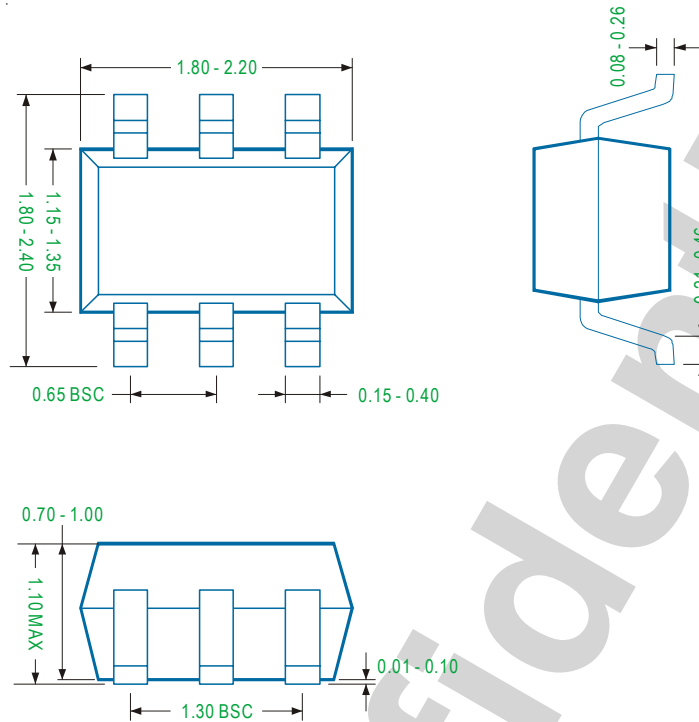

**Note**

**1. Package Outline Unit Description:**

BSC: Basic. Represents theoretical exact dimension or dimension target.

MIN: Minimum dimension specified.

MAX: Maximum dimension specified.

REF: Reference. Represents dimension for reference use only. This value is not a device specification.

TYP: Typical. Provided as a general value. This value is not a device specification.

**2. Dimensions in Millimeters.**

**3. Drawing not to scale.**

**4. These dimensions do not include mold flash or protrusions. Mold flash or protrusions shall not exceed 0.15mm.**

## Important Notice

uPI and its subsidiaries reserve the right to make corrections, modifications, enhancements, improvements, and other changes to its products and services at any time and to discontinue any product or service without notice. Customers should obtain the latest relevant information before placing orders and should verify that such information is current and complete.

uPI products are sold subject to the terms and conditions of sale supplied at the time of order acknowledgment. However, no responsibility is assumed by uPI or its subsidiaries for its use or application of any product or circuit; nor for any infringements of patents or other rights of third parties which may result from its use or application, including but not limited to any consequential or incidental damages. No uPI components are designed, intended or authorized for use in military, aerospace, automotive applications nor in systems for surgical implantation or life-sustaining. No license is granted by implication or otherwise under any patent or patent rights of uPI or its subsidiaries.

COPYRIGHT (c) 2015, UPI SEMICONDUCTOR CORP.

### **uPI Semiconductor Corp.**

Headquarter  
9F., No. 5, Taiyuan 1st St. Zhubei City,  
Hsinchu Taiwan, R.O.C.  
TEL : 886.3.560.1666 FAX : 886.3.560.1888

Sales Branch Office  
12F-5, No. 408, Ruiguang Rd. Neihu District,  
Taipei Taiwan, R.O.C.  
TEL : 886.2.8751.2062 FAX : 886.2.8751.5064