

EX-20 SERIES Ver.2

Related Information

- General terms and conditions..... F-3
- Selection guide P.231~
- Glossary of terms / General precautions . P.1549~ / P.1552~
- Korea's S-mark..... P.1602

Ver.2



PNP output type available

Miniature-sized and still mountable with M3 screws

Miniaturization by using single chip optical IC

The beam-receiving photodiode and the A/D conversion circuit have been fabricated on a single chip optical IC (full custom). Hence, in spite of its miniature size, it has a performance and reliability which is equal to or better than the conventional product.

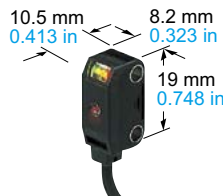

Incorporates a sensitivity adjuster even in this size

The sensor incorporates a sensitivity adjuster in spite of its miniature size. It is convenient when you need fine adjustment. Further, the receiver of the thru-beam, side sensing type sensor incorporates an operation mode switch which can change the output operation.



BASIC PERFORMANCE

Long sensing range

The EX-20 series achieves long distance sensing [thru-beam type: 2 m **6.562 ft**, retroreflective type: 200 mm **7.874 in** (when using the attached reflector), diffuse reflective type: 160 mm **6.299 in**], despite its miniature size. Hence, it is usable even on a wide conveyor.

Thru-beam type

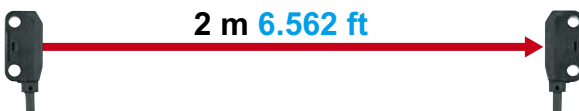

Retroreflective type

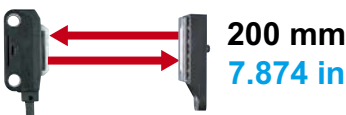

Diffuse reflective type



Clear beam spot using red LED dot light source

The emission area of a dot light source is smaller than that of a conventional LED flat light source, and it is possible to design a high power, narrow beam. Since a red LED dot light source is used, the red beam spot is clear even at a far place, so that alignment and confirmation of sensing position is easy. Further, since the thru-beam type, too, incorporates a visible narrow beam, it can also reliably detect small parts, such as, chip components, lead frames, etc.

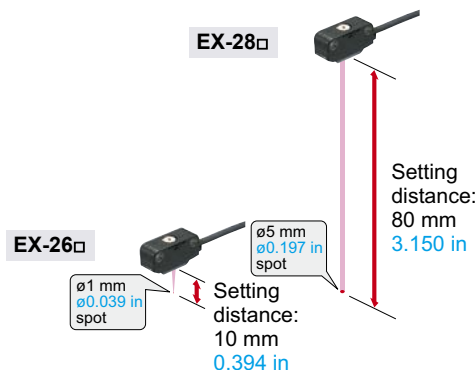

- FIBER SENSORS
- LASER SENSORS
- PHOTOELECTRIC SENSORS
- MICRO PHOTOELECTRIC SENSORS
- AREA SENSORS
- SAFETY LIGHT CURTAINS / SAFETY COMPONENTS
- PRESSURE / FLOW SENSORS
- INDUCTIVE PROXIMITY SENSORS
- PARTICULAR USE SENSORS
- SENSOR OPTIONS
- SIMPLE WIRE-SAVING UNITS
- WIRE-SAVING SYSTEMS
- MEASUREMENT SENSORS
- STATIC CONTROL DEVICES
- LASER MARKERS
- PLC
- HUMAN MACHINE INTERFACES
- ENERGY MANAGEMENT SOLUTIONS
- FA COMPONENTS
- MACHINE VISION SYSTEMS
- UV CURING SYSTEMS
- Selection Guide
- Amplifier Built-in
- Power Supply Built-in
- Amplifier-separated
- EX-Z
- CX-400
- CY-100
- EX-10
- EX-20
- EX-30
- EX-40
- CX-440
- EQ-30
- EQ-500
- MQ-W
- RX-LS200
- RX
- RT-610

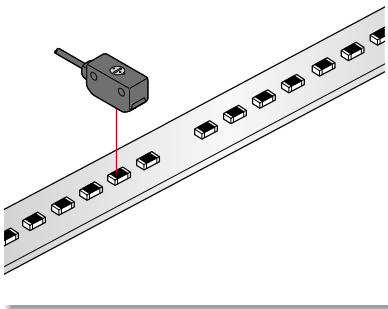
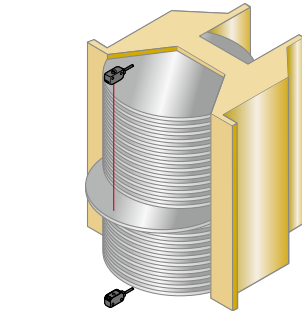
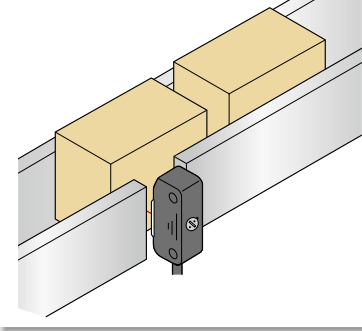
APPLICATIONS**Detecting presence of chip components****Checking protrusion of wafer****Sensing objects from an opening****BASIC PERFORMANCE****Electric power saving***

The EX-20 series achieves reductions in power consumption of up to 65%. These sensors contribute to environmental friendliness.

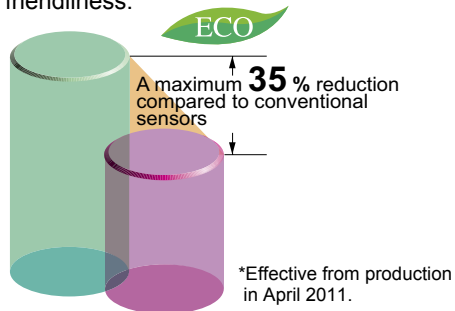
**ENVIRONMENTAL RESISTANCE****Waterproof IP67 (IEC)**

The sensors features an IP67 rating to allow their use in process lines where water is used or splashed. Rust-resistant stainless steel sensor mounting brackets are available.

Note: If water splashes on the sensor during sensing operation, it may sense water as an object.

Incorporated an inverter countermeasure circuit*

The EX-20 series become significantly stronger against inverter light and other extraneous light.

*Effective from production in April 2011.

MOUNTING**Identical size**

Front sensing type of thru-beam type and diffuse reflective type sensors have identical appearance. Moreover, since the mounting holes are symmetrical with respect to the beam axis center, the design becomes easy.

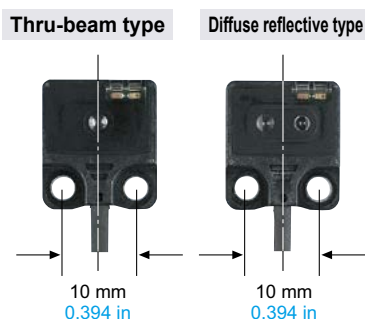
**Mounting section reinforced**

It can be tightened with M3 screws. Moreover, metal inserts have been provided in the mounting holes so that the product is not damaged even in case of excess tightening.

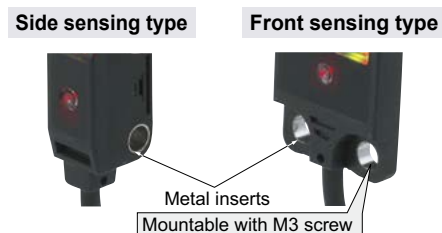
**OPTIONS****Universal sensor mounting bracket is available**

Universal sensor mounting bracket MS-EXL2-4 (for EX-22/23/26/28/29□) and MS-EX20-5 (for EX-23□ only) which can freely adjust the height and the angle of the sensor is available.

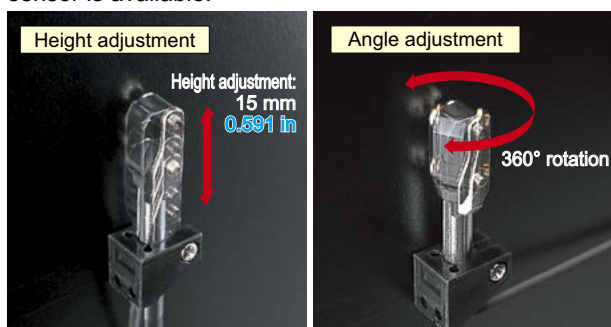
**Mounting spacer for front sensing type is available**

Mounting of the front sensing type is possible from the rear side by using the mounting spacer.

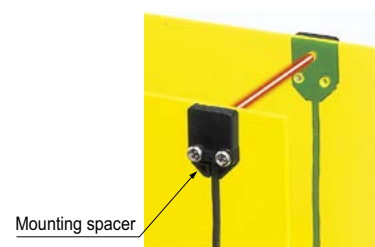
**Slit mask is available**

ø0.5 mm ø0.020 in round slit mask and 0.5 × 3 mm 0.020 × 0.118 in rectangular slit mask are available for both side sensing type and front sensing type sensors.

FIBER SENSORS

LASER SENSORS

PHOTOELECTRIC SENSORS

MICRO PHOTOELECTRIC SENSORS

AREA SENSORS

SAFETY LIGHT CURTAINS / SAFETY COMPONENTS

PRESSURE / FLOW SENSORS

INDUCTIVE PROXIMITY SENSORS

PARTICULAR USE SENSORS

SENSOR OPTIONS

SIMPLE WIRE-SAVING UNITS

WIRE-SAVING SYSTEMS

MEASUREMENT SENSORS

STATIC CONTROL DEVICES

LASER MARKERS

PLC

HUMAN MACHINE INTERFACES

ENERGY MANAGEMENT SOLUTIONS

FA COMPONENTS

MACHINE VISION SYSTEMS

UV CURING SYSTEMS

Selection Guide

Amplifier Built-in

Power Supply Built-in

Amplifier-separated

EX-Z

CX-400

CY-100

EX-10

EX-20

EX-30

EX-40

CX-440

EQ-30

EQ-500

MQ-W

RX-LS200

RX

RT-610

- FIBER SENSORS
- LASER SENSORS
- PHOTO-ELECTRIC SENSORS
- MICRO PHOTO-ELECTRIC SENSORS
- AREA SENSORS
- SAFETY LIGHT CURTAINS / SAFETY COMPONENTS
- PRESSURE / FLOW SENSORS
- INDUCTIVE PROXIMITY SENSORS
- PARTICULAR USE SENSORS
- SENSOR OPTIONS
- WIRE-SAVING UNITS
- WIRE-SAVING SYSTEMS
- MEASUREMENT SENSORS
- STATIC CONTROL DEVICES
- LASER MARKERS
- PLC
- HUMAN MACHINE INTERFACES
- ENERGY MANAGEMENT SOLUTIONS
- FA COMPONENTS
- MACHINE VISION SYSTEMS
- UV CURING SYSTEMS
- Selection Guide
- Amplifier Built-in
- Power Supply Built-in
- Amplifier-separated
- EX-Z
- CX-400
- CY-100
- EX-10
- EX-20
- EX-30
- EX-40
- CX-440
- EQ-30
- EQ-500
- MQ-W
- RX-LS200
- RX
- RT-610

FUNCTIONS

Bright 2-color indicator

A bright 2-color indicator has been incorporated in all types. (Orange LED: Operation indicator, Green LED: Stability indicator)

VARIETIES

Two types for suitable mounting

Two types, side sensing type and front sensing type sensors are available. Select depending on the place of mounting.

Side sensing type

Front sensing type



(With sensitivity adjuster)



(Without sensitivity adjuster)

ORDER GUIDE

Type	Appearance	Sensing range	Model No. (Note 3)	Output	Output operation	
Thru-beam	Front sensing	1 m 3.281 ft	EX-21A	NPN open-collector transistor	Light-ON	
			EX-21A-PN	PNP open-collector transistor		
	Side sensing	2 m 6.562 ft	EX-21B	NPN open-collector transistor	Dark-ON	
			EX-21B-PN	PNP open-collector transistor		
Retroreflective	Side sensing	30 to 200 mm 1.181 to 7.874 in (Note 1)	EX-23	NPN open-collector transistor	Switchable either Light-ON or Dark-ON	
			EX-23-PN	PNP open-collector transistor		
			EX-29A	NPN open-collector transistor	Light-ON	
			EX-29A-PN	PNP open-collector transistor		
Diffuse reflective	Side sensing	5 to 160 mm 0.197 to 6.299 in (Note 2)	EX-29B	NPN open-collector transistor	Dark-ON	
			EX-29B-PN	PNP open-collector transistor		
			EX-22A	NPN open-collector transistor	Light-ON	
			EX-22A-PN	PNP open-collector transistor		
Convergent reflective	Diffused beam type	2 to 25 mm 0.079 to 0.984 in (Convergent point: 10 mm 0.394 in)	EX-22B	NPN open-collector transistor	Dark-ON	
			EX-22B-PN	PNP open-collector transistor		
	Small spot beam type	Front sensing	2 to 25 mm 0.079 to 0.984 in (Convergent point: 10 mm 0.394 in)	EX-24A	NPN open-collector transistor	Light-ON
				EX-24A-PN	PNP open-collector transistor	
Narrow-view reflective	Small spot beam type	6 to 14 mm 0.236 to 0.551 in (Convergent point: 10 mm 0.394 in)	EX-24B	NPN open-collector transistor	Dark-ON	
			EX-24B-PN	PNP open-collector transistor		
	Long distance spot beam type	Side sensing	45 to 115 mm 1.772 to 4.528 in	EX-26A	NPN open-collector transistor	Light-ON
				EX-26A-PN	PNP open-collector transistor	
Narrow-view reflective	Long distance spot beam type	45 to 115 mm 1.772 to 4.528 in	EX-26B	NPN open-collector transistor	Dark-ON	
			EX-26B-PN	PNP open-collector transistor		
	Long distance spot beam type	Side sensing	45 to 115 mm 1.772 to 4.528 in	EX-28A	NPN open-collector transistor	Light-ON
				EX-28A-PN	PNP open-collector transistor	
Long distance spot beam type	Side sensing	45 to 115 mm 1.772 to 4.528 in	EX-28B	NPN open-collector transistor	Dark-ON	
			EX-28B-PN	PNP open-collector transistor		

NOTE: Mounting bracket is not supplied with the sensor. Please select from the range of optional sensor mounting brackets (four types) or universal sensor mounting bracket. (Refer to p.297)

- Notes: 1) The sensing range of the retroreflective type sensor is specified for the **RF-200** reflector. Further, the sensing range is the possible setting range for the reflector. The sensor can detect an object less than 30 mm 1.181 in away. However, if the reflector is set 100 mm 3.937 in or less away, the sensing object should be opaque.
- 2) In case of using this product at a sensing range of 50 mm 1.969 in or less, take care that the sensitivity adjustment range becomes extremely narrow.
- 3) The model No. with "P" shown on the label affixed to the thru-beam type sensor is the emitter, "D" shown on the label is the receiver.

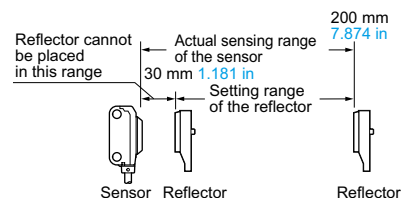

ORDER GUIDE

Package without reflector

Retroreflective type is also available without the reflector **RF-200**.
When ordering this type, suffix “-Y” to the model No.
(e.g.) Without reflector type of **EX-29A-PN** is “**EX-29A-PN-Y**”.

5 m 16.404 ft cable length type

5 m 16.404 ft cable length type (standard: 2 m 6.562 ft) is also available for NPN output type (including package without reflector of retroreflective type sensor).
When ordering this type, suffix “-C5” to the model No.
(e.g.) 5 m 16.404 ft cable length type of **EX-29A-Y** is “**EX-29A-Y-C5**”.

Accessory

- **RF-200** (Reflector)



OPTIONS

Designation	Model No.	Description	
Round slit mask (For thru-beam type sensor only)	OS-EX20-05 (Slit size $\varnothing 0.5$ mm 0.020 in)	Slit on one side	• Sensing range: 200 mm 7.874 in • Min. sensing object: $\varnothing 2.6$ mm $\varnothing 0.102$ in
		Slit on both sides	• Sensing range: 40 mm 1.575 in • Min. sensing object: $\varnothing 0.5$ mm $\varnothing 0.020$ in
	OS-EX20E-05 (Slit size $\varnothing 0.5$ mm 0.020 in)	Slit on one side	• Sensing range: 350 mm 13.780 in • Min. sensing object: $\varnothing 3$ mm $\varnothing 0.118$ in
		Slit on both sides	• Sensing range: 70 mm 2.756 in • Min. sensing object: $\varnothing 0.5$ mm $\varnothing 0.020$ in
Rectangular slit mask (For thru-beam type sensor only)	OS-EX20-05×3 (Slit size 0.5 × 3 mm 0.020 × 0.118 in)	Slit on one side	• Sensing range: 600 mm 23.622 in • Min. sensing object: $\varnothing 2.6$ mm $\varnothing 0.102$ in
		Slit on both sides	• Sensing range: 300 mm 11.811 in • Min. sensing object: 0.5 × 3 mm 0.020 × 0.118 in
	OS-EX20E-05×3 (Slit size 0.5 × 3 mm 0.020 × 0.118 in)	Slit on one side	• Sensing range: 800 mm 31.496 in • Min. sensing object: $\varnothing 3$ mm $\varnothing 0.118$ in
		Slit on both sides	• Sensing range: 400 mm 15.748 in • Min. sensing object: 0.5 × 3 mm 0.020 × 0.118 in
Reflector (For retroreflective type sensor only)	RF-210	• Sensing range: 50 to 400 mm 1.969 to 15.748 in • Min. sensing object: $\varnothing 30$ mm $\varnothing 1.181$ in	
Reflector mounting bracket	MS-RF21-1	Protective mounting bracket for RF-210 It protects the reflector from damage and maintains alignment.	
Reflective tape (For retroreflective type sensor only)	RF-11	• Ambient temperature: -25 to +50 °C -13 to +122 °F • Ambient humidity: 35 to 85 % RH	• Sensing range: 70 to 200 mm 2.756 to 7.874 in
	RF-12	Notes • Keep the tape free from stress. If it is pressed too much, its capability may deteriorate. • Do not cut the tape. It will deteriorate the sensing performance.	• Sensing range: 60 to 280 mm 2.362 to 11.024 in

Round slit mask

Fitted on the front face of the sensor with one-touch.

- **OS-EX20-05**
- **OS-EX20E-05**

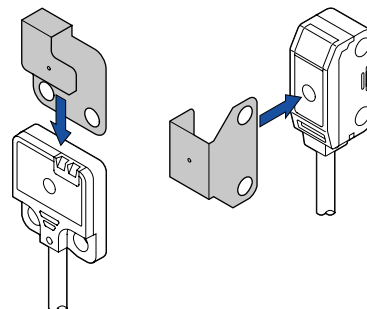

Rectangular slit mask

Fitted on the front face of the sensor with one-touch.

- **OS-EX20-05×3**
- **OS-EX20E-05×3**

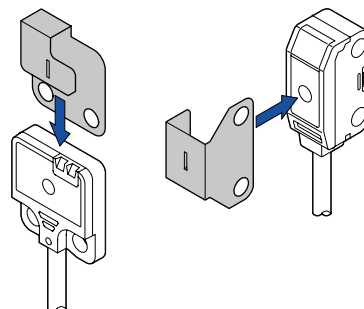

Reflector

- **RF-210**

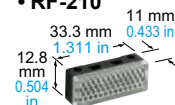

Reflector mounting bracket

- **MS-RF21-1**

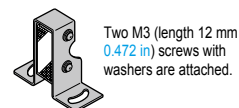

- **RF-11**

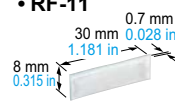

- **RF-12**

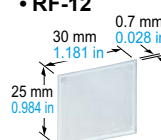

FIBER SENSORS

LASER SENSORS

PHOTO-ELECTRIC SENSORS

MICRO PHOTO-ELECTRIC SENSORS

AREA SENSORS

SAFETY LIGHT CURTAINS / SAFETY COMPONENTS

PRESSURE / FLOW SENSORS

INDUCTIVE PROXIMITY SENSORS

PARTICULAR USE SENSORS

SENSOR OPTIONS

SIMPLE WIRE-SAVING UNITS

WIRE-SAVING SYSTEMS

MEASUREMENT SENSORS

STATIC CONTROL DEVICES

LASER MARKERS

PLC

HUMAN MACHINE INTERFACES

ENERGY MANAGEMENT SOLUTIONS

FA COMPONENTS

MACHINE VISION SYSTEMS

UV CURING SYSTEMS

Selection Guide

Amplifier Built-in

Power Supply Built-in

Amplifier-separated

EX-Z

CX-400

CY-100

EX-10

EX-20

EX-30

EX-40

CX-440

EQ-30

EQ-500

MQ-W

RX-LS200

RX

RT-610

OPTIONS

Designation	Model No.	Description
Sensor mounting bracket	MS-EX20-1	Back angled mounting bracket for front sensing type sensor (The thru-beam type sensor needs two brackets.)
	MS-EX20-2	Foot angled mounting bracket for side sensing type sensor (The thru-beam type sensor needs two brackets.)
	MS-EX20-3	L-shaped mounting bracket for front sensing type sensor (The thru-beam type sensor needs two brackets.)
	MS-EX20-4	Back angled mounting bracket for side sensing type sensor (The thru-beam type sensor needs two brackets.)
Universal sensor mounting bracket (Note 1)	MS-EXL2-4	For EX-22□/23□/26□/EX-28□/29□ It can adjust the height and the angle of the sensor. (The thru-beam type sensor needs two brackets.)
	MS-EX20-5	For EX-23□ only
Mounting spacer (For front sensing type sensor only)	MS-EX20-FS	It is used when mounting the front sensing type from the rear side. (One set consists of 10 pcs.)
Sensor checker (Note 2)	CHX-SC2	It is useful for beam alignment of thru-beam type sensors. The optimum receiver position is given by indicators, as well as an audio signal.

Notes: 1) Note that the axis position of **EX-23□** is different when replacing the mounting bracket **MS-EX20-5** with **MS-EXL2-4**.
 2) Refer to p.959~ for the sensor checker **CHX-SC2**.

Sensor mounting bracket

• **MS-EX20-1**

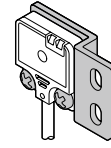

Material: Stainless steel (SUS304)
 Two M3 (length 5 mm 0.197 in) pan head screws [stainless steel (SUS304)] are attached.

• **MS-EX20-2**

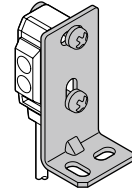

Material: Stainless steel (SUS304)
 Two M3 (length 14 mm 0.551 in) screws with washers [stainless steel (SUS304)] are attached.

• **MS-EX20-3**

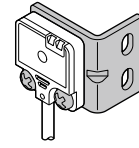

Material: Stainless steel (SUS304)
 Two M3 (length 5 mm 0.197 in) pan head screws [stainless steel (SUS304)] are attached.

• **MS-EX20-4**

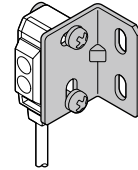

Material: Stainless steel (SUS304)
 Two M3 (length 14 mm 0.551 in) screws with washers [stainless steel (SUS304)] are attached.

Sensor checker

• **CHX-SC2**

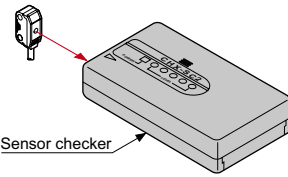

Sensor checker

Mounting spacer

• **MS-EX20-FS**

One set consists of 10 pcs.

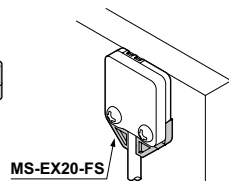

MS-EX20-FS

Universal sensor mounting bracket

• **MS-EXL2-4**

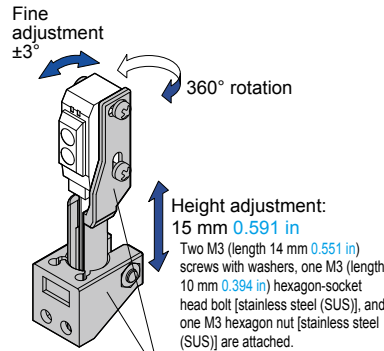

Fine adjustment $\pm 3^\circ$
 360° rotation

Height adjustment: 15 mm 0.591 in
 Two M3 (length 14 mm 0.551 in) screws with washers, one M3 (length 10 mm 0.394 in) hexagon-socket head bolt [stainless steel (SUS)], and one M3 hexagon nut [stainless steel (SUS)] are attached.

Material: Die-cast zinc alloy

• **MS-EX20-5**

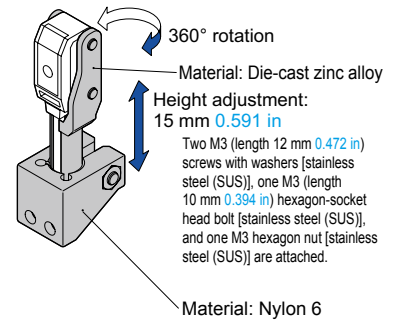

360° rotation
 Material: Die-cast zinc alloy
 Height adjustment: 15 mm 0.591 in
 Two M3 (length 12 mm 0.472 in) screws with washers [stainless steel (SUS)], one M3 (length 10 mm 0.394 in) hexagon-socket head bolt [stainless steel (SUS)], and one M3 hexagon nut [stainless steel (SUS)] are attached.

Material: Nylon 6

FIBER SENSORS

LASER SENSORS

PHOTO-ELECTRIC SENSORS

MICRO PHOTO-ELECTRIC SENSORS

AREA SENSORS

SAFETY LIGHT CURTAINS / SAFETY COMPONENTS

PRESSURE / FLOW SENSORS

INDUCTIVE PROXIMITY SENSORS

PARTICULAR USE SENSORS

SENSOR OPTIONS

SIMPLE WIRE-SAVING UNITS

WIRE-SAVING SYSTEMS

MEASUREMENT SENSORS

STATIC CONTROL DEVICES

LASER MARKERS

PLC

HUMAN MACHINE INTERFACES

ENERGY MANAGEMENT SOLUTIONS

FA COMPONENTS

MACHINE VISION SYSTEMS

UV CURING SYSTEMS

EX-Z

CX-400

CY-100

EX-10

EX-20

EX-30

EX-40

CX-440

EQ-30

EQ-500

MQ-W

RX-LS200

RX

RT-610

Selection Guide

Amplifier Built-in

Power Supply Built-in

Amplifier-separated

SPECIFICATIONS

Item	Model No. (Note 2)	Type	Thru-beam		Retroreflective	Diffuse reflective	Convergent reflective		Narrow-view reflective
			Front sensing	Side sensing	Side sensing	Side sensing	Diffused beam type	Small spot beam type	Long distance spot beam type
			Light-ON	Dark-ON	EX-21A(-PN)	EX-23(-PN) (Note 3)	EX-29A(-PN)	EX-22A(-PN)	EX-24A(-PN)
			EX-21B(-PN)		EX-29B(-PN)	EX-22B(-PN)	EX-24B(-PN)	EX-26B(-PN)	EX-28B(-PN)
CE marking directive compliance			EMC Directive, RoHS Directive						
Sensing range			1 m 3.281 ft	2 m 6.562 ft	30 to 200 mm 1.181 to 7.874 in (Note 4)	5 to 160 mm 0.197 to 6.299 in (Note 5) with white non-glossy paper (200 × 200 mm) (7.874 × 7.874 in)	2 to 25 mm 0.079 to 0.984 in (Conv. point: 10 mm 0.394 in) with white non-glossy paper (50 × 50 mm) (1.969 × 1.969 in)	6 to 14 mm 0.236 to 0.551 in (Conv. point: 10 mm 0.394 in) with white non-glossy paper (50 × 50 mm) 1.969 × 1.969 in, spot diameter ø1 mm ø0.039 in with setting distance 10 mm 0.394 in	45 to 115 mm 1.772 to 4.528 in with white non-glossy paper (100 × 100 mm 3.937 × 3.937 in), spot diameter ø5 mm ø0.197 in with setting distance 80 mm 3.150 in
Sensing object			Min. ø2.6 mm ø0.102 in opaque object (Setting distance between emitter and receiver: 1 m 3.281 ft)	Min. ø3 mm ø0.118 in opaque object (Setting distance between emitter and receiver: 2 m 6.562 ft)	ø15 mm ø0.591 in or more opaque or translucent object (Note 4, 6)	Opaque, translucent or transparent object (Note 6)	Min. ø0.1 mm ø0.004 in copper wire (Setting distance: 10 mm 0.394 in)	Min. ø0.1 mm ø0.004 in copper wire (Setting distance: 10 mm 0.394 in)	Opaque, translucent or transparent object (Note 6) (Min. ø1 mm ø0.039 in copper wire at setting distance 80 mm 3.150 in)
Hysteresis			—————						
Repeatability (perpendicular to sensing axis)			0.05 mm 0.002 in or less		0.5 mm 0.020 in or less	0.3 mm 0.012 in or less	0.1 mm 0.004 in or less (Setting distance: 10 mm 0.394 in)	0.05 mm 0.002 in or less (Setting distance: 10 mm 0.394 in)	0.3 mm 0.012 in or less
Supply voltage			12 to 24 V DC ±10 % Ripple P-P 10 % or less						
Current consumption			Emitter: 10 mA or less, Receiver: 10 mA or less		13 mA or less			15 mA or less	
Output			<NPN output type> NPN open-collector transistor • Maximum sink current: 50 mA • Applied voltage: 30 V DC or less (between output and 0 V) • Residual voltage: 2 V or less (at 50 mA sink current) 1 V or less (at 16 mA sink current)			<PNP output type> PNP open-collector transistor • Maximum source current: 50 mA • Applied voltage: 30 V DC or less (between output and +V) • Residual voltage: 2 V or less (at 50 mA source current) 1 V or less (at 16 mA source current)			
Utilization category			DC-12 or DC-13						
Short-circuit protection			Incorporated						
Response time			0.5 ms or less						
Operation indicator			Orange LED (lights up when the output is ON) (thru-beam type: located on the receiver)						
Stability indicator			Green LED (lights up under stable light received condition or stable dark condition), located on the receiver		Green LED (lights up under stable light received condition or stable dark condition)				
Sensitivity adjuster			—————	Continuously variable adjuster, located on the emitter	Continuously variable adjuster		—————	Continuously variable adjuster	
Operation mode switch			—————	Located on the receiver		—————			
Environmental resistance	Pollution degree		3 (Industrial environment)						
	Protection		IP67 (IEC)						
	Ambient temperature		-25 to +55 °C -13 to +131 °F (No dew condensation or icing allowed), Storage: -30 to +70 °C -22 to +158 °F						
	Ambient humidity		35 to 85 % RH, Storage: 35 to 85 % RH						
	Ambient illuminance		Incandescent light: 3,000 lx or less at the light-receiving face						
	Voltage withstandability		1,000 V AC for one min. between all supply terminals connected together and enclosure						
	Insulation resistance		20 MΩ, or more, with 250 V DC megger between all supply terminals connected together and enclosure						
	Vibration resistance		10 to 500 Hz frequency, 3 mm 0.118 in double amplitude (20 G max.) in X, Y and Z directions for two hours each						
Shock resistance		500 m/s ² acceleration (50 G approx.) in X, Y and Z directions three times each							
Emitting element			Red LED (modulated)						
Peak emission wavelength			640 nm 0.025 mil	650 nm 0.026 mil	680 nm 0.027 mil	680 nm 0.027 mil	680 nm 0.027 mil	650 nm 0.026 mil	650 nm 0.026 mil
Material			Enclosure: Polyarylate, Lens: Polyarylate						
Cable			0.1 mm ² 3-core (thru-beam type sensor emitter: 2-core) cabtyre cable, 2 m 6.562 ft long						
Cable extension			Extension up to total 50 m 164.042 ft is possible with 0.3 mm ² , or more, cable (thru-beam type: both emitter and receiver).						
Weight			Net weight (each emitter and receiver): 20 g approx. Gross weight: 60 g approx.		Net weight: 20 g approx., Gross weight: 45 g approx.				
Accessories			—————	Adjusting screwdriver: 1 pc.	RF-200 (Reflector): 1 pc. Adjusting screwdriver: 1 pc.	Adjusting screwdriver: 1 pc.	—————	Adjusting screwdriver: 1 pc.	

Notes: 1) Where measurement conditions have not been specified precisely, the conditions used were an ambient temperature of +23 °C +73.4 °F.

2) Model Nos. having the suffix "-PN" are PNP output type.

3) Either Light-ON or Dark-ON can be selected by the operation mode switch (located on the receiver).

4) The sensing range and the sensing object of the retroreflective type sensor are specified for the **RF-200** reflector. Further, the sensing range is the possible setting range for the reflector. The sensor can detect an object less than 30 mm 1.181 in away. However, if the reflector is set 100 mm 3.937 in or less away, the sensing object should be opaque.

5) In case of using this product at a sensing range of 50 mm 1.969 in or less, take care that the sensitivity adjustment range becomes extremely narrow.

6) Make sure to confirm detection with an actual sensor before use.

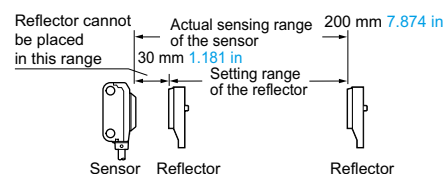

FIBER SENSORS

LASER SENSORS

PHOTO-ELECTRIC SENSORS

MICRO PHOTO-ELECTRIC SENSORS

AREA SENSORS

SAFETY LIGHT CURTAINS / SAFETY COMPONENTS

PRESSURE / FLOW SENSORS

INDUCTIVE PROXIMITY SENSORS

PARTICULAR USE SENSORS

SENSOR OPTIONS

SIMPLE WIRE-SAVING UNITS

WIRE-SAVING SYSTEMS

MEASUREMENT SENSORS

STATIC CONTROL DEVICES

LASER MARKERS

PLC

HUMAN MACHINE INTERFACES

ENERGY MANAGEMENT SOLUTIONS

FA COMPONENTS

MACHINE VISION SYSTEMS

UV CURING SYSTEMS

Selection Guide

Amplifier Built-in

Power Supply Built-in

Amplifier-separated

EX-Z

CX-400

CY-100

EX-10

EX-20

EX-30

EX-40

CX-440

EQ-30

EQ-500

MQ-W

RX-LS200

RX

RT-610

FIBER SENSORS
LASER SENSORS
PHOTO-ELECTRIC SENSORS
MICRO PHOTO-ELECTRIC SENSORS
AREA SENSORS
SAFETY LIGHT CURTAINS / SAFETY COMPONENTS
PRESSURE / FLOW SENSORS
INDUCTIVE PROXIMITY SENSORS
PARTICULAR USE SENSORS
SENSOR OPTIONS
SIMPLE WIRE-SAVING UNITS
WIRE-SAVING SYSTEMS
MEASUREMENT SENSORS
STATIC CONTROL DEVICES
LASER MARKERS
PLC
HUMAN MACHINE INTERFACES
ENERGY MANAGEMENT SOLUTIONS
FA COMPONENTS
MACHINE VISION SYSTEMS
UV CURING SYSTEMS

I/O CIRCUIT AND WIRING DIAGRAMS

NPN output type

I/O circuit diagram

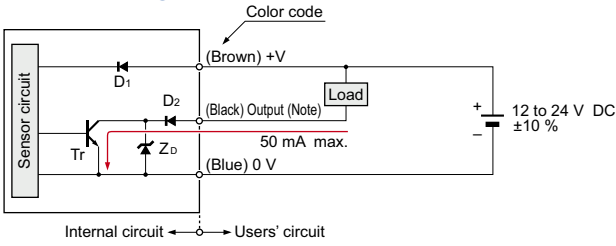

Wiring diagram

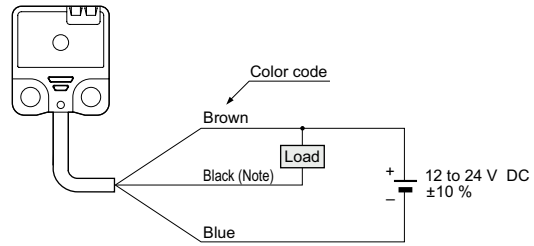

Note: The emitter of the thru-beam type sensor does not incorporate the output.

Note: The emitter of the thru-beam type sensor does not incorporate the black wire.

Symbols ... D1: Reverse supply polarity protection diode
D2: Reverse output polarity protection diode
ZD: Surge absorption zener diode
Tr : NPN output transistor

PNP output type

I/O circuit diagram

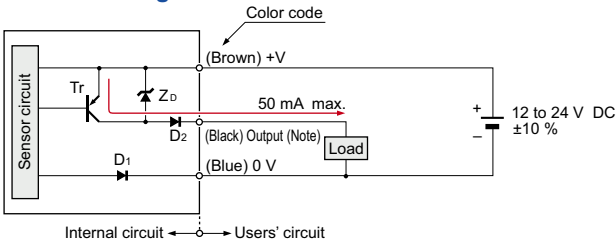

Wiring diagram

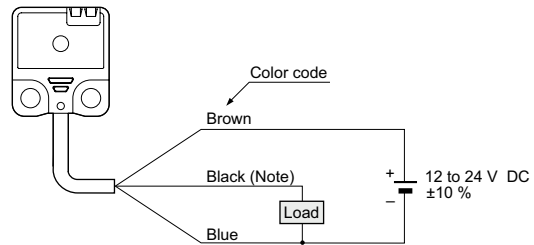

Note: The emitter of the thru-beam type sensor does not incorporate the output.

Note: The emitter of the thru-beam type sensor does not incorporate the black wire.

Symbols ... D1: Reverse supply polarity protection diode
D2: Reverse output polarity protection diode
ZD: Surge absorption zener diode
Tr : PNP output transistor

SENSING CHARACTERISTICS (TYPICAL)

EX-21 □ EX-23 □ EX-29 □ EX-22 □

Correlation between setting distance and excess gain

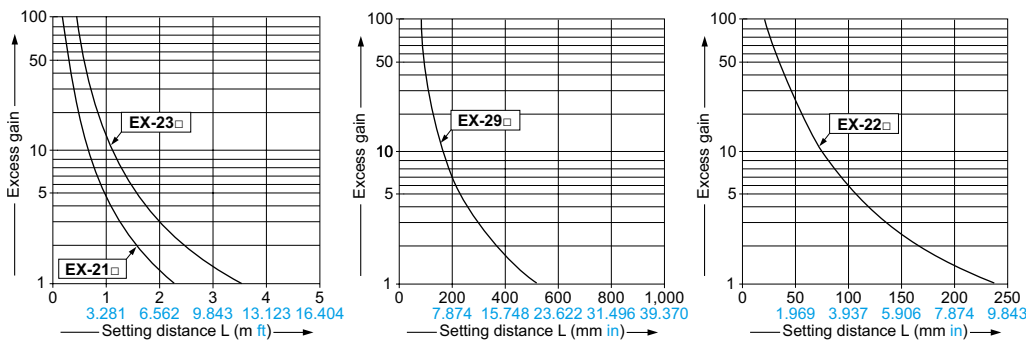

EX-21 □

Thru-beam type

Parallel deviation

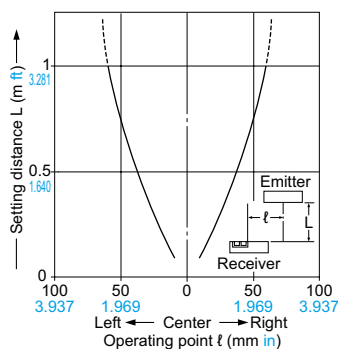

Angular deviation

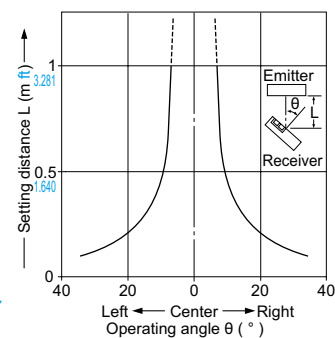

Parallel deviation with round slit masks (ø0.5 mm ø0.020 in)

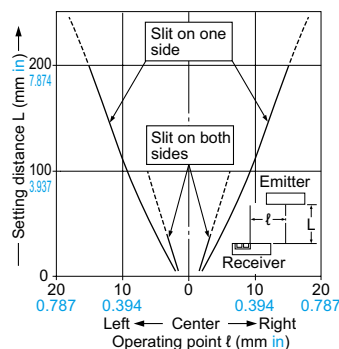

Parallel deviation with rectangular slit masks (0.5 × 3 mm 0.020 × 0.118 in)

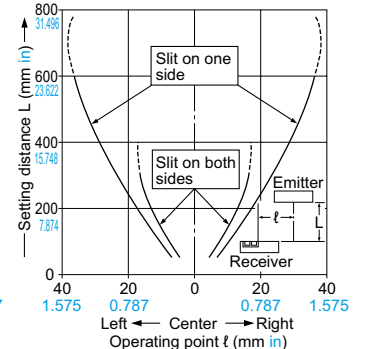

Selection Guide
Amplifier Built-in
Power Supply Built-in
Amplifier-separated
EX-Z
CX-400
CY-100
EX-10
EX-20
EX-30
EX-40
CX-440
EQ-30
EQ-500
MQ-W
RX-LS200
RX
RT-610

SENSING CHARACTERISTICS (TYPICAL)

EX-23 □

Thru-beam type

Parallel deviation

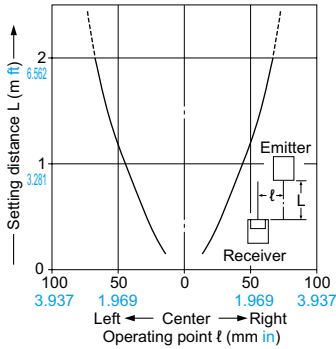

Angular deviation

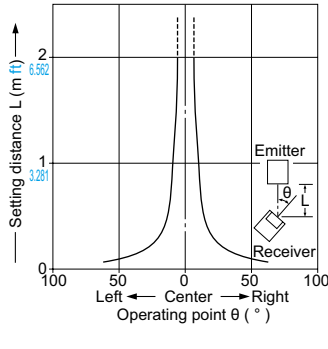

Parallel deviation with round slit masks (ø0.5 mm ø0.020 in)

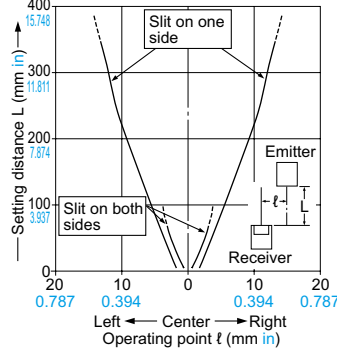

Parallel deviation with rectangular slit masks (0.5 x 3 mm 0.020 x 0.118 in)

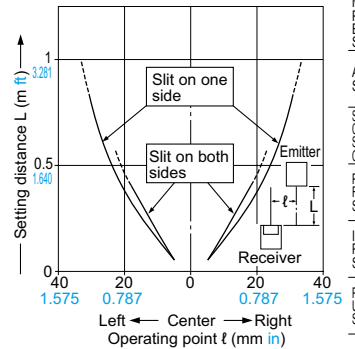

EX-29 □

Retroreflective type

Parallel deviation

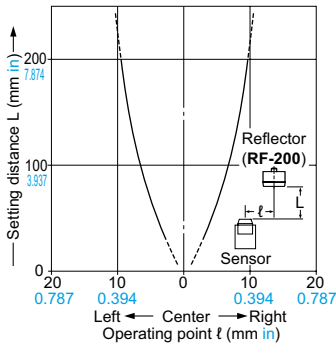

Angular deviation

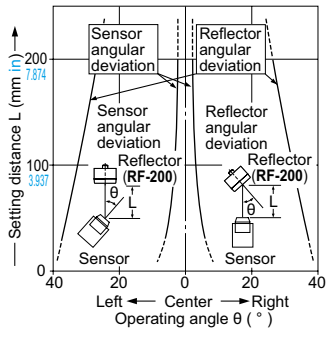

EX-22 □

Diffuse reflective type

Sensing field

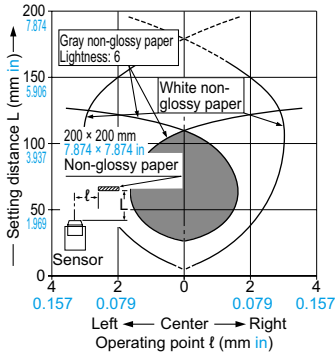

Correlation between sensing object size and sensing range

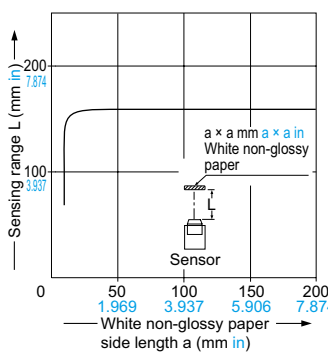

As the sensing object size becomes smaller than the standard size (white non-glossy paper 200 x 200 mm 7.874 x 7.874 in), the sensing range shortens, as shown in the left graph.

EX-24 □

Convergent reflective type

Sensing fields

• Horizontal (left and right) direction

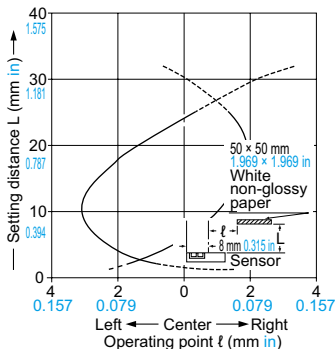

• Vertical (up and down) direction

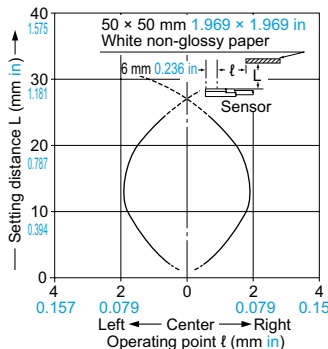

FIBER SENSORS

LASER SENSORS

PHOTO-ELECTRIC SENSORS

MICRO PHOTO-ELECTRIC SENSORS

AREA SENSORS

SAFETY LIGHT CURTAINS / SAFETY COMPONENTS

PRESSURE / FLOW SENSORS

INDUCTIVE PROXIMITY SENSORS

PARTICULAR USE SENSORS

SENSOR OPTIONS

SIMPLE WIRE-SAVING UNITS

WIRE-SAVING SYSTEMS

MEASUREMENT SENSORS

STATIC CONTROL DEVICES

LASER MARKERS

PLC

HUMAN MACHINE INTERFACES

ENERGY MANAGEMENT SOLUTIONS

FA COMPONENTS

MACHINE VISION SYSTEMS

UV CURING SYSTEMS

Selection Guide

Amplifier Built-in

Power Supply Built-in

Amplifier-separated

EX-Z

CX-400

CY-100

EX-10

EX-20

EX-30

EX-40

CX-440

EQ-30

EQ-500

MQ-W

RX-LS200

RX

RT-610

SENSING CHARACTERISTICS (TYPICAL)

EX-24

Convergent reflective type

Correlation between lightness and sensing range

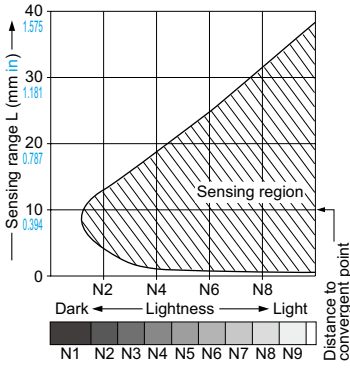

The sensing region (typical) is represented by oblique lines in the left figure. However, the sensitivity should be set with enough margin because of slight variation in products.

(Lightness shown on the left may differ slightly from the actual object condition.)

Correlation between material (50 × 50 mm 1.969 × 1.969 in) and sensing range

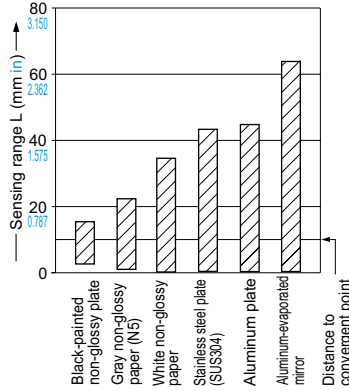

The bars in the graph indicate the sensing range (typical) for the respective material. However, there is a slight variation in the sensing range depending on the product. Further, if there is a reflective object (conveyor, etc.) in the background of the sensing object, since it affects the sensing, separate it by more than twice the sensing range shown in the left graph.

EX-26

Convergent reflective type

Sensing fields

• Horizontal (left and right) direction

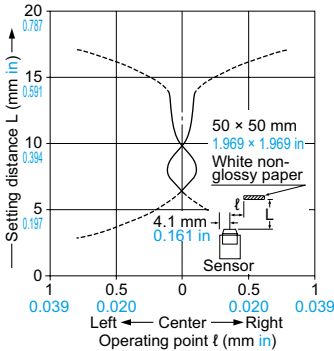

• Vertical (up and down) direction

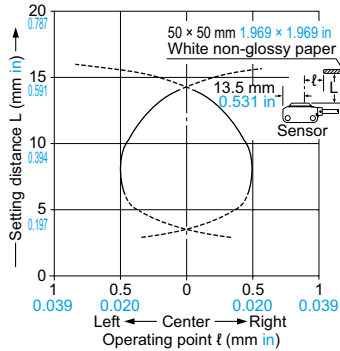

Correlation between lightness and sensing range

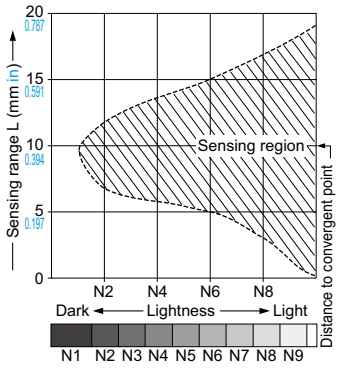

The sensing region (typical) is represented by oblique lines in the left figure. However, the sensitivity should be set with enough margin because of slight variation in products.

(The graph is drawn for the maximum sensitivity setting.)

(Lightness shown on the left may differ slightly from the actual object condition.)

Correlation between material (50 × 50 mm 1.969 × 1.969 in) and sensing range

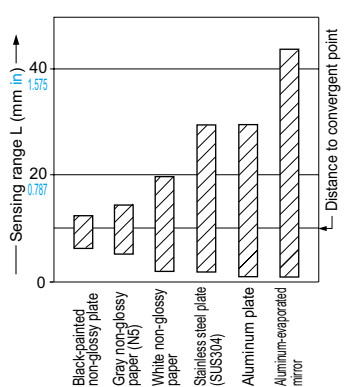

The bars in the graph indicate the sensing range (typical) for the respective material. However, there is a slight variation in the sensing range depending on the product. Further, if there is a reflective object (conveyor, etc.) in the background of the sensing object, since it affects the sensing, separate it by more than twice the sensing range shown in the left graph, or adjust the sensitivity adjuster.

(The graph is drawn for the maximum sensitivity setting.)

EX-28

Narrow-view reflective type

Sensing field

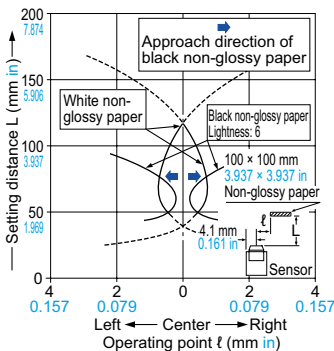

Correlation between sensing object size and sensing range

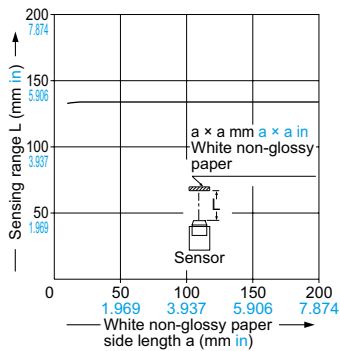

As the sensing object size becomes smaller than the standard size (white non-glossy paper 100 × 100 mm 3.937 × 3.937 in), the sensing range shortens, as shown in the left graph.

FIBER SENSORS
LASER SENSORS
PHOTO-ELECTRIC SENSORS
MICRO PHOTO-ELECTRIC SENSORS
AREA SENSORS
SAFETY LIGHT CURTAINS / SAFETY COMPONENTS
PRESSURE / FLOW SENSORS
INDUCTIVE PROXIMITY SENSORS
PARTICULAR USE SENSORS
SENSOR OPTIONS
SIMPLE WIRE-SAVING UNITS
WIRE-SAVING SYSTEMS
MEASURE-MENT SENSORS
STATIC CONTROL DEVICES
LASER MARKERS
PLC
HUMAN MACHINE INTERFACES
ENERGY MANAGEMENT SOLUTIONS
FA COMPONENTS
MACHINE VISION SYSTEMS
UV CURING SYSTEMS
Selection Guide
Amplifier Built-in
Power Supply Built-in
Amplifier-separated
EX-Z
CX-400
CY-100
EX-10
EX-20
EX-30
EX-40
CX-440
EQ-30
EQ-500
MQ-W
RX-LS200
RX
RT-610

PRECAUTIONS FOR PROPER USE

Refer to p.1552~ for general precautions.

FIBER SENSORS

LASER SENSORS

PHOTO-ELECTRIC SENSORS

MICRO PHOTO-ELECTRIC SENSORS

AREA SENSORS

SAFETY LIGHT CURTAINS / SAFETY COMPONENTS

PRESSURE / FLOW SENSORS

INDUCTIVE PROXIMITY SENSORS

PARTICULAR USE SENSORS

SENSOR OPTIONS

SIMPLE WIRE-SAVING UNITS

WIRE-SAVING SYSTEMS

MEASUREMENT SENSORS

STATIC CONTROL DEVICES

LASER MARKERS

PLC

HUMAN MACHINE INTERFACES

ENERGY MANAGEMENT SOLUTIONS

FA COMPONENTS

MACHINE VISION SYSTEMS

UV CURING SYSTEMS

Selection Guide

Amplifier Built-in

Power Supply Built-in

Amplifier-separated

EX-Z

CX-400

CY-100

EX-10

EX-20

EX-30

EX-40

CX-440

EQ-30

EQ-500

MQ-W

RX-LS200

RX

RT-610



- Never use this product as a sensing device for personnel protection.
- In case of using sensing devices for personnel protection, use products which meet laws and standards, such as OSHA, ANSI or IEC etc., for personnel protection applicable in each region or country.

Mounting

- Mount using M3 screws. The tightening torque should be 0.5 N·m or less.

Front sensing

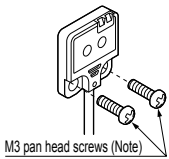

M3 pan head screws (Note)

Note: When mounting the front sensing type sensor, use M3 pan head screws without washers, etc.

Side sensing

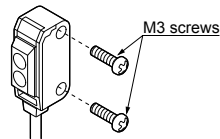

- When mounting the front sensing type from the backside, fit the mounting spacer (**MS-EX20-FS**) and fix with screws.

Mounting method



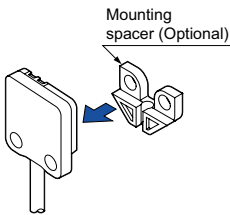

- ① Fit the mounting spacer on the sensor.

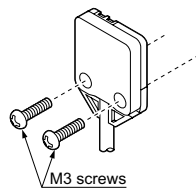

- ② Align the mounting holes of the mounting spacer and the sensor and mount with M3 screws. The tightening torque should be 0.5 N·m or less.





Sensitivity adjustment (side sensing type only)

Step	Sensitivity adjuster	Description
①		Turn the sensitivity adjuster fully counterclockwise to the minimum sensitivity position (- mark).
②		In the light received condition, turn the sensitivity adjuster slowly clockwise and confirm the point (A) where the sensor enters the "Light" state operation.
③		In the dark condition, turn the sensitivity adjuster further clockwise until the sensor enters the "Light" state operation and then bring it back to confirm point (B) where the sensor just returns to the "Dark" state operation. (If the sensor does not enter the "Light" state operation even when the sensitivity adjuster is turned fully clockwise, this extreme position is point (B).)
④		The position at the middle of points (A) and (B) is the optimum sensing position.

Notes: 1) Use the attached adjusting screwdriver to turn the adjuster slowly. Turning with excessive strength will damage the adjuster.
2) In case of using **EX-22** at a sensing distance of 50 mm 1.969 in or less, take care that the sensitivity adjustment range becomes extremely narrow.

Operation mode switch (EX-23 only)

Switch position	Description
	Light-ON mode is obtained when the operation mode switch (located on the receiver) is turned fully clockwise (L side).
	Dark-ON mode is obtained when the operation mode switch (located on the receiver) is turned fully counterclockwise (D side).

Note: Operation mode switch should be turned fully till it stops.

Stability indicator

- The stability indicator (green) lights up when the incident light intensity has sufficient margin with respect to the operation level.

If the incident light intensity level is such that the stability indicator lights up, stable sensing can be done without the light received operation and the light interrupted operation being affected by a change in ambient temperature or supply voltage.

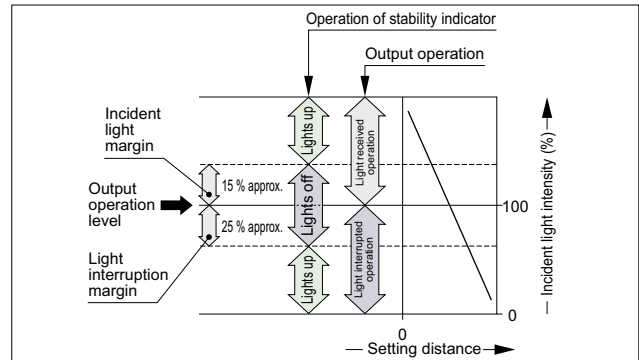

Glossy object sensing (EX-29)

- Please take care of the following points when detecting materials having a gloss.

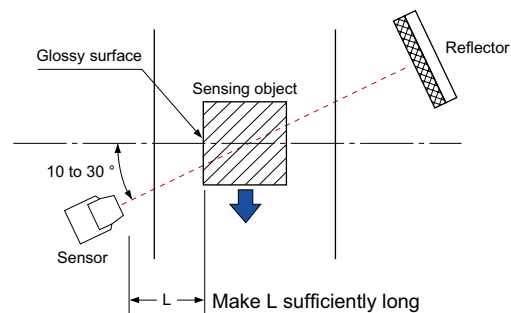

Wiring

- Excess bending of the cable or stress applied to the cable may disconnect the internal lead wire.

Others

- Do not use during the initial transient time (50 ms) after the power supply is switched on.
- If sensors are mounted close together and the ambient temperature is near the maximum rated value, provide for enough heat radiation / ventilation.
- If a reflective object is present in the background, the sensing of **EX-28** may be affected. When setting the sensor, make sure to confirm that the reflective object has no effect. In case the reflective object affects the sensing, take measures such as removing the reflective object or coloring it in black, etc.

DIMENSIONS (Unit: mm in)

The CAD data can be downloaded from our website.

FIBER SENSORS

LASER SENSORS

PHOTO-ELECTRIC SENSORS

MICRO PHOTO-ELECTRIC SENSORS

AREA SENSORS

SAFETY LIGHT CURTAINS / SAFETY COMPONENTS

PRESSURE / FLOW SENSORS

INDUCTIVE PROXIMITY SENSORS

PARTICULAR USE SENSORS

SENSOR OPTIONS

SIMPLE WIRE-SAVING UNITS

WIRE-SAVING SYSTEMS

MEASURE-MENT SENSORS

STATIC CONTROL DEVICES

LASER MARKERS

PLC

HUMAN MACHINE INTERFACES

ENERGY MANAGEMENT SOLUTIONS

FA COMPONENTS

MACHINE VISION SYSTEMS

UV CURING SYSTEMS

Selection Guide

Amplifier Built-in

Power Supply Built-in

Amplifier-separated

EX-Z

CX-400

CY-100

EX-10

EX-20

EX-30

EX-40

CX-440

EQ-30

EQ-500

MQ-W

RX-LS200

RX

RT-610

EX-21 □ Sensor

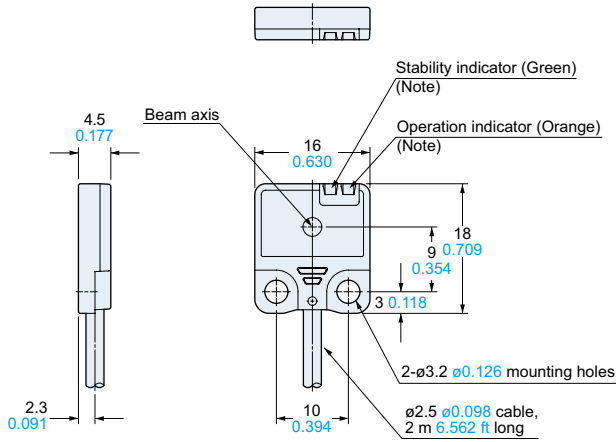

Note: Not incorporated on the emitter.

EX-23 □ Sensor

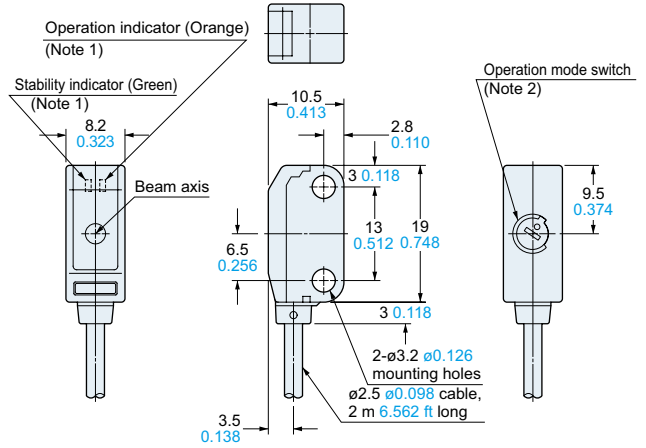

Notes: 1) Not incorporated on the emitter.
2) It is the sensitivity adjuster on the emitter.

EX-29 □ **EX-22** □ **EX-26** □ **EX-28** □ Sensor

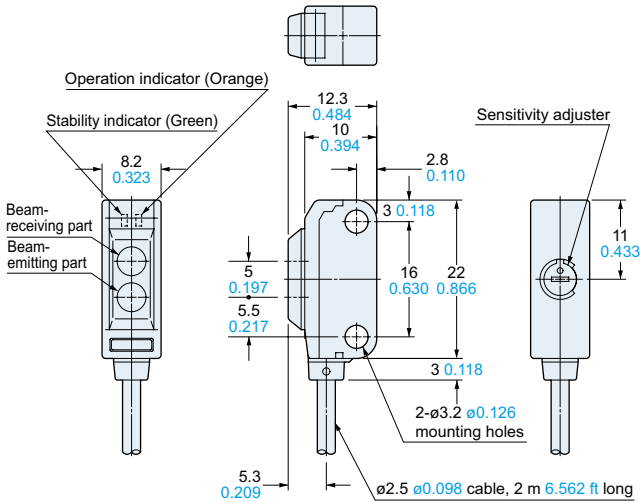

EX-24 □ Sensor

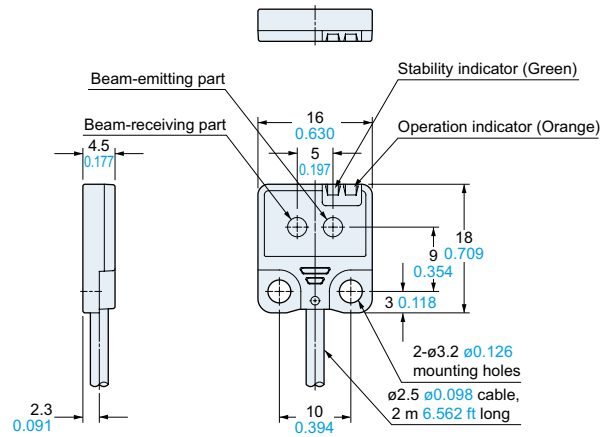

RF-200 Reflector (Accessory for the retroreflective type sensor)

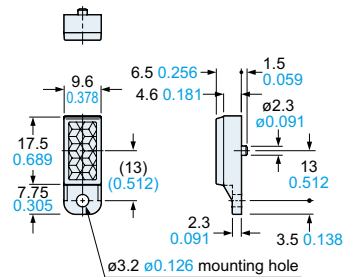

Material: Acrylic (Reflector)
ABS (Base)

RF-210 Reflector (Optional)

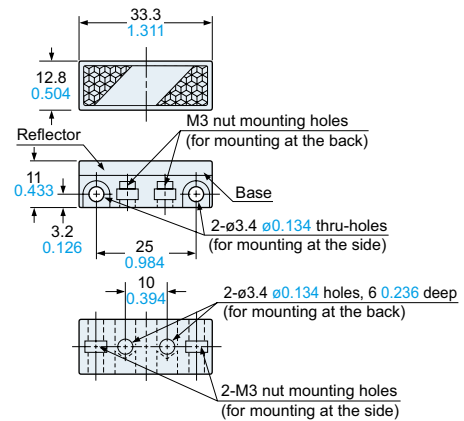

Material: Acrylic (Reflector) ABS (Base)

Two M3 (length 8 mm 0.315 in) screws with washers and two nuts are attached.

DIMENSIONS (Unit: mm in)

The CAD data can be downloaded from our website.

RF-11 Reflective tape (Optional)

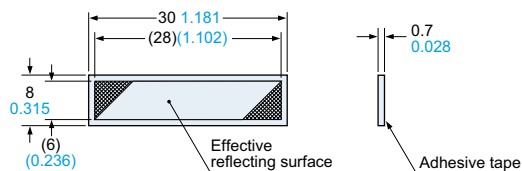

Material: Acrylic

RF-12 Reflective tape (Optional)

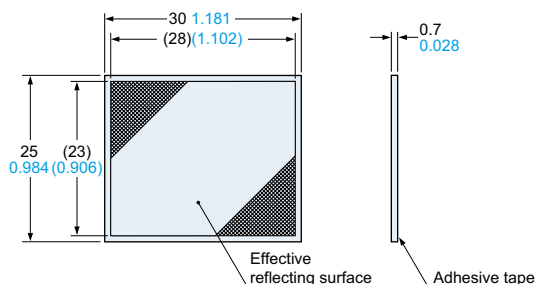

Material: Flexible polyvinyl chloride

MS-RF21-1 Reflector mounting bracket for RF-210 (Optional)

Assembly dimensions

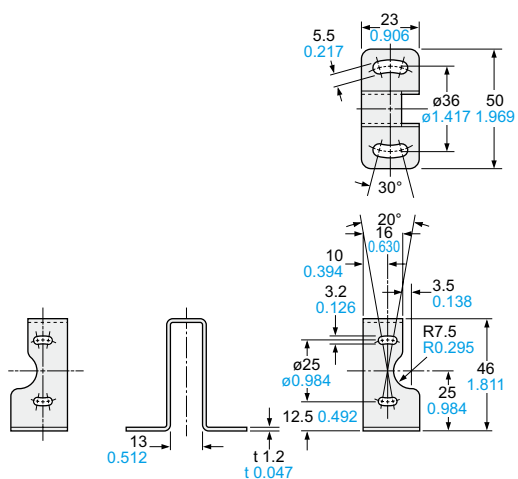

Material: Stainless steel (SUS304)
Two M3 (length 12 mm 0.472 in) screws with washers are attached.

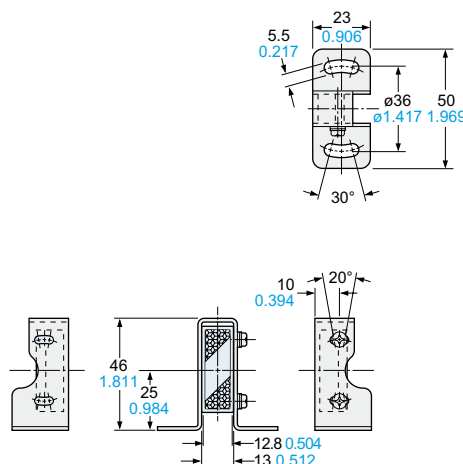

MS-EX20-1 Sensor mounting bracket (Optional)

Assembly dimensions

Mounting drawing with EX-21□

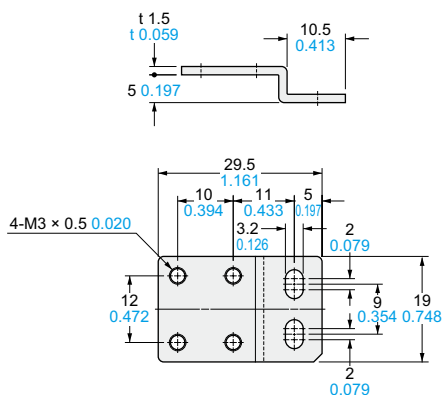

Material: Stainless steel (SUS304)
Two M3 (length 5 mm 0.197 in) pan head screws [stainless steel (SUS304)] are attached.

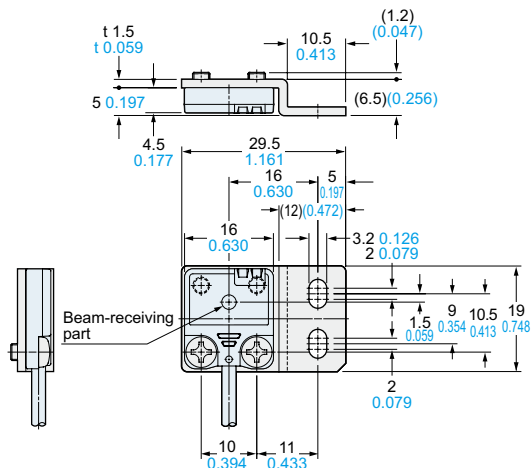

FIBER SENSORS

LASER SENSORS

PHOTO-ELECTRIC SENSORS

MICRO PHOTO-ELECTRIC SENSORS

AREA SENSORS

SAFETY LIGHT CURTAINS / SAFETY COMPONENTS

PRESSURE / FLOW SENSORS

INDUCTIVE PROXIMITY SENSORS

PARTICULAR USE SENSORS

SENSOR OPTIONS

SIMPLE WIRE-SAVING UNITS

WIRE-SAVING SYSTEMS

MEASUREMENT SENSORS

STATIC CONTROL DEVICES

LASER MARKERS

PLC

HUMAN MACHINE INTERFACES

ENERGY MANAGEMENT SOLUTIONS

FA COMPONENTS

MACHINE VISION SYSTEMS

UV CURING SYSTEMS

Selection Guide

Amplifier Built-in

Power Supply Built-in

Amplifier-separated

EX-Z

CX-400

CY-100

EX-10

EX-20

EX-30

EX-40

CX-440

EQ-30

EQ-500

MQ-W

RX-LS200

RX

RT-610

DIMENSIONS (Unit: mm in)

The CAD data can be downloaded from our website.

FIBER SENSORS

LASER SENSORS

PHOTO-ELECTRIC SENSORS

MICRO PHOTO-ELECTRIC SENSORS

AREA SENSORS

SAFETY LIGHT CURTAINS / SAFETY COMPONENTS

PRESSURE / FLOW SENSORS

INDUCTIVE PROXIMITY SENSORS

PARTICULAR USE SENSORS

SENSOR OPTIONS

SIMPLE WIRE-SAVING UNITS

WIRE-SAVING SYSTEMS

MEASURE-MENT SENSORS

STATIC CONTROL DEVICES

LASER MARKERS

PLC

HUMAN MACHINE INTERFACES

ENERGY MANAGEMENT SOLUTIONS

FA COMPONENTS

MACHINE VISION SYSTEMS

UV CURING SYSTEMS

Selection Guide

Amplifier Built-in

Power Supply Built-in

Amplifier-separated

MS-EX20-2

Sensor mounting bracket (Optional)

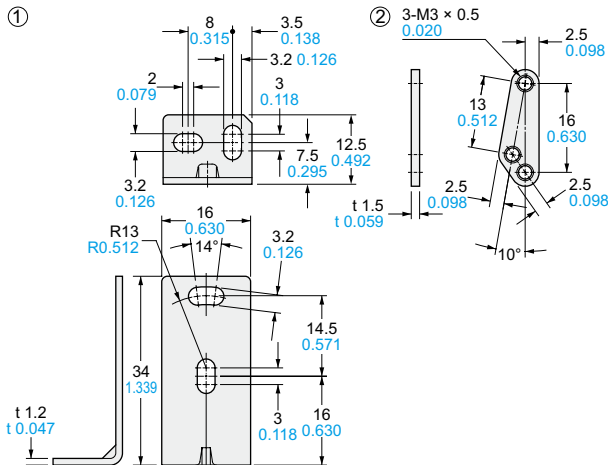

Material: Stainless steel (SUS304)
Two M3 (length 14 mm 0.551 in) screws with washers [stainless steel (SUS304)] are attached.

Assembly dimensions

Mounting drawing with the receiver of EX-23 □

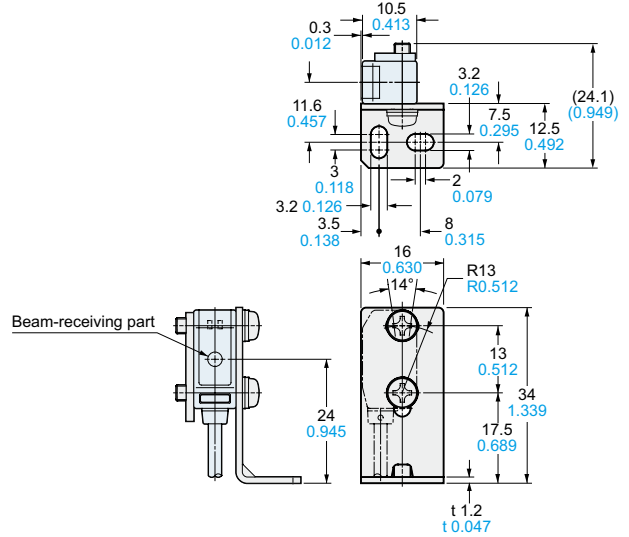

MS-EX20-3

Sensor mounting bracket (Optional)

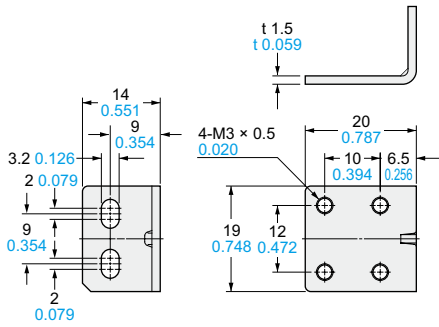

Material: Stainless steel (SUS304)
Two M3 (length 5 mm 0.197 in) pan head screws [stainless steel (SUS304)] are attached.

Assembly dimensions

Mounting drawing with the receiver of EX-21 □

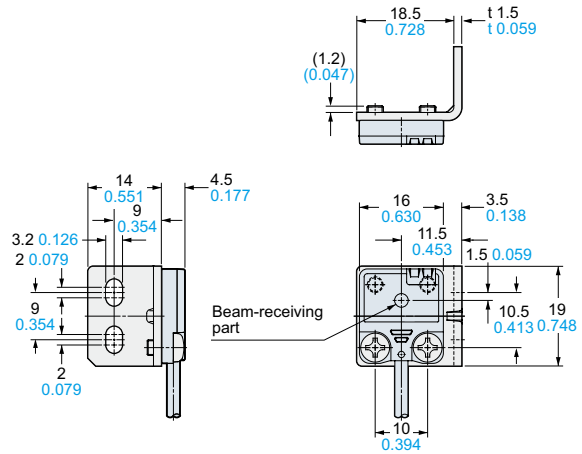

MS-EX20-4

Sensor mounting bracket (Optional)

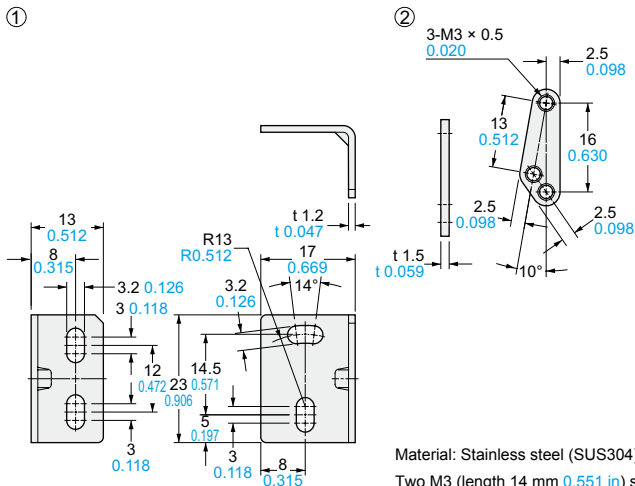

Material: Stainless steel (SUS304)
Two M3 (length 14 mm 0.551 in) screws with washers [stainless steel (SUS304)] are attached.

Assembly dimensions

Mounting drawing with the receiver of EX-23 □

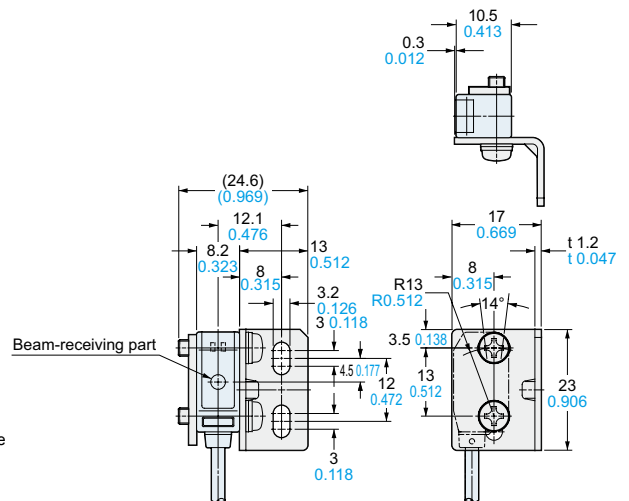

EX-Z

CX-400

CY-100

EX-10

EX-20

EX-30

EX-40

CX-440

EQ-30

EQ-500

MQ-W

RX-LS200

RX

RT-610

DIMENSIONS (Unit: mm in)

The CAD data can be downloaded from our website.

MS-EXL2-4

Universal sensor mounting bracket (Optional)

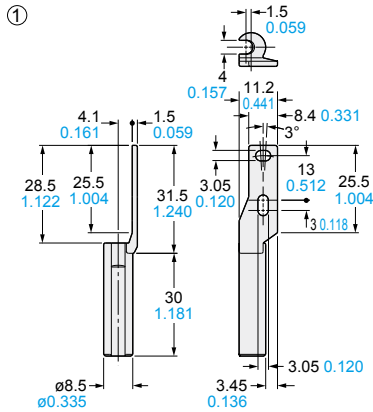

Material: Die-cast zinc alloy
Two M3 (length 14 mm 0.551 in) screws with washers, one M3 (length 10 mm 0.394 in) hexagon socket-head bolt [stainless steel (SUS)], and one M3 hexagon nut [stainless steel (SUS)] are attached.

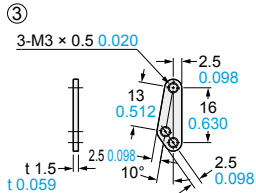

Material: Stainless steel (SUS)

Assembly dimensions

Mounting drawing with EX-22□/26□/28□/29□

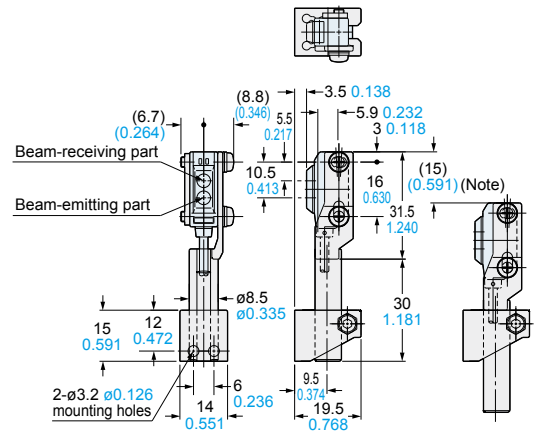

Note: This is the adjustable range of the movable part.

MS-EX20-5

Universal sensor mounting bracket (Optional)

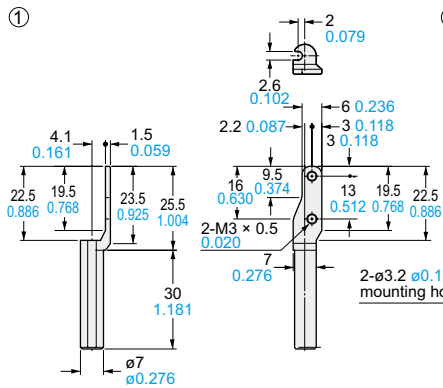

Material: Die-cast zinc alloy
Two M3 (length 12 mm 0.472 in) screws with washers [stainless steel (SUS)], one M3 (length 10 mm 0.394 in) hexagon socket-head bolt [stainless steel (SUS)], and one M3 hexagon nut [stainless steel (SUS)] are attached.

Material: Nylon 6

Assembly dimensions

Mounting drawing with the receiver of EX-23□

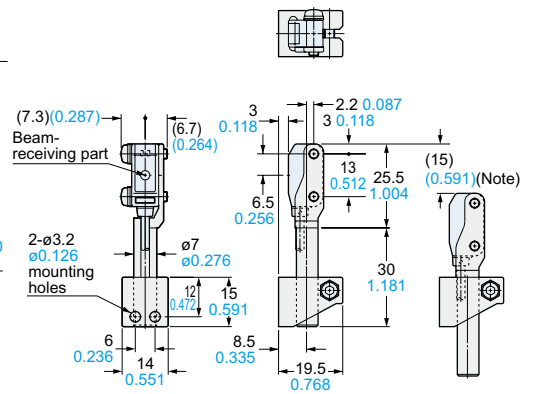

Note: This is the adjustable range of the movable part.

MS-EX20-FS

Mounting spacer (Optional)

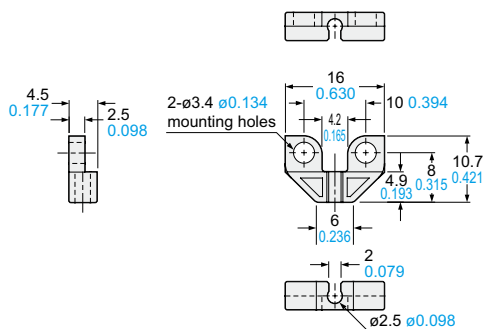

Material: Polycarbonate

Assembly dimensions

Mounting drawing with the receiver of EX-21□

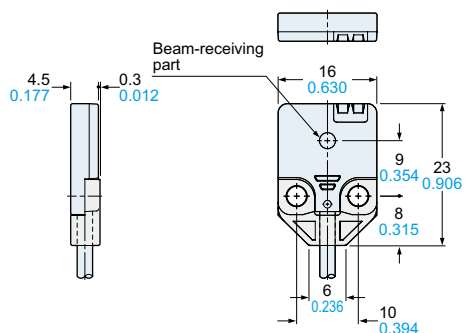

FIBER SENSORS

LASER SENSORS

PHOTO-ELECTRIC SENSORS

MICRO PHOTO-ELECTRIC SENSORS

AREA SENSORS

SAFETY LIGHT CURTAINS / SAFETY COMPONENTS

PRESSURE / FLOW SENSORS

INDUCTIVE PROXIMITY SENSORS

PARTICULAR USE SENSORS

SENSOR OPTIONS

SMALL WIRE-SAVING UNITS

WIRE-SAVING SYSTEMS

MEASUREMENT SENSORS

STATIC CONTROL DEVICES

LASER MARKERS

PLC

HUMAN MACHINE INTERFACES

ENERGY MANAGEMENT SOLUTIONS

FA COMPONENTS

MACHINE VISION SYSTEMS

UV CURING SYSTEMS

Selection Guide

Amplifier Built-in

Power Supply Built-in

Amplifier-separated

EX-Z

CX-400

CY-100

EX-10

EX-20

EX-30

EX-40

CX-440

EQ-30

EQ-500

MQ-W

RX-LS200

RX

RT-610